

# Service Manual

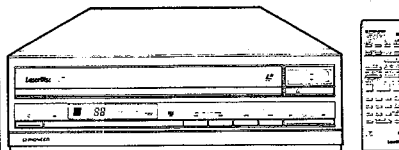

**ORDER NO.  
ARP 1373**

**COMPACT DISC/LASERVISION PLAYER**

**NTSC**

# CLD-1010



LaserVision



**MODEL CLD-1010 COMES IN TWO VERSIONS DISTINGUISHED AS FOLLOWS:**

Type	Power requirement	Export destination
KUC	AC 120 V only	U.S.A., Canada
S/G	AC 110 V, 120 V, 220 V, 240 V (switchable)	U.S. Military

- This service manual is applicable to the KUC and S/G types.
- As to the S/G type, please refer to page 109.

## CONTENTS

1. SAFETY INFORMATION.....	2	8.2 REGB, LSFB, PWSB, CAPB, BLMB AND CNNB ASSEMBLY.....	29
2. SPECIFICATIONS .....	3	8.3 DSDC ASSEMBLY (D.S.D SECTION) .....	33
3. PANEL FACILITIES.....	5	8.4 DSDC ASSEMBLY (CONTROL SECTION) ...	37
4. DISASSEMBLY .....	10	8.5 SRVB AND TIMB ASSEMBLY .....	41
5. EXPLODED VIEWS AND PARTS LIST		8.6 VDEM ASSEMBLY .....	45
5.1 EXTERIOR AND FRONT VIEW .....	12	8.7 STBC ASSEMBLY .....	49
5.2 TOP VIEW .....	14	8.8 ADEM, CALB, DISP, KEYB, SENS AND MODB ASSEMBLY.....	53
5.3 BOTTOM VIEW .....	16	8.9 PICK-UP ASSEMBLY .....	57
5.4 MECHANISM ASSEMBLY VIEW .....	18	9. ELECTRICAL PARTS LIST .....	61
5.5 CARRY ASSEMBLY VIEW .....	20	10. HOW TO REPLACE THE PICK-UP ASSEMBLY?.....	68
5.6 PICK-UP ASSEMBLY VIEW .....	22	11. MECHANICAL ADJUSTMENT.....	70
5.7 REMOTE CONTROL UNIT.....	24	12. ELECTRICAL ADJUSTMENT .....	86
6. PACKING .....	25	13. FOR S/G TYPE.....	109
7. P.C. BOARDS LOCATION.....	26		
8. SCHEMATIC DIAGRAM AND P.C. BOARD PATTERNS			
8.1 OVERALL CONNECTION DIAGRAMS.....	27		

**PIONEER ELECTRONIC CORPORATION** 4-1, Meguro 1-Chome, Meguro-ku, Tokyo 153, Japan  
**PIONEER ELECTRONICS SERVICE INC.** P.O. Box 1760, Long Beach, California 90801 U.S.A.  
**PIONEER ELECTRONICS OF CANADA, INC.** 505 Cochrane Drive, Markham, Ontario L3R 6B8 Canada TEL: [416] 479-4411  
**PIONEER ELECTRONIC [EUROPE] N.V.** Keetberglaan 1, 2740 Beveren, Belgium TEL: 03/775 · 28 · 08  
**PIONEER ELECTRONICS AUSTRALIA PTY. LTD.** 178-184 Boundary Road, Braeside, Victoria 3195, Australia TEL: [03] 580-9911

# 1. SAFETY INFORMATION

## 1. SAFETY PRECAUTIONS

The following check should be performed for the continued protection of the customer and service technician.

### LEAKAGE CURRENT CHECK

Measure leakage current to a known earth ground (water pipe, conduit, etc.) by connecting a leakage current tester such as Simpson Model 229-2 or equivalent between the earth ground and all exposed metal parts of the appliance (input/output terminals, screwheads, metal overlays, control shaft, etc.). Plug the AC line cord of the appliance directly into a 120V AC 60Hz outlet and turn the AC power switch on. Any current measured must not exceed 0.5mA.

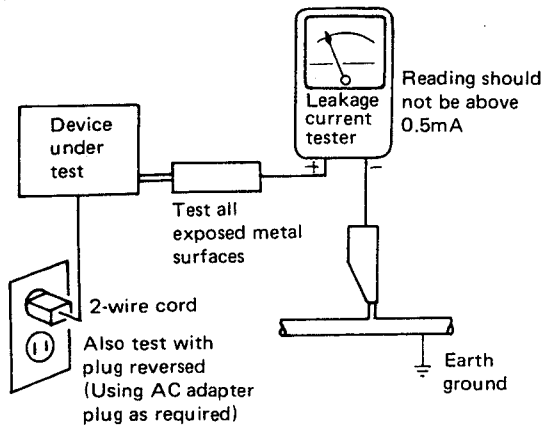

AC Leakage Test

**ANY MEASUREMENTS NOT WITHIN THE LIMITS OUTLINED ABOVE ARE INDICATIVE OF A POTENTIAL SHOCK HAZARD AND MUST BE CORRECTED BEFORE RETURNING THE APPLIANCE TO THE CUSTOMER.**

## 2. PRODUCT SAFETY NOTICE

Many electrical and mechanical parts in the appliance have special safety related characteristics. These are often not evident from visual inspection nor the protection afforded by them necessarily can be obtained by using replacement components rated for voltage, wattage, etc. Replacement parts which have these special safety characteristics are identified in this Service Manual.

Electrical components having such features are identified by marking with a  $\Delta$  on the schematics and on the parts list in this Service Manual.

The use of a substitute replacement component which does not have the same safety characteristics as the PIONEER recommended replacement one, shown in the parts list in this Service Manual, may create shock, fire, or other hazards.

Product Safety is continuously under review and new instructions are issued from time to time. For the latest information, always consult the current PIONEER Service Manual. A subscription to, or additional copies of, PIONEER Service Manual may be obtained at a nominal charge from PIONEER.

## 2. SPECIFICATIONS

### 1. General

System.....LaserVision Disc system and Compact Disc digital audio system  
 Laser.....Semiconductor laser wavelength 780 nm

Power requirements  
 U.S. and Canadian models.....AC 120 V, 50/60 Hz  
 U.S. Military model.....AC 110/120/220/240 V (Switchable), 50/60 Hz

Power consumption  
 U.S. and Canadian models.....48 W  
 U.S. Military model.....44 W

Weight.....11.5 kg (25 lb 6 oz)  
 Dimensions.....420(W) x 411(D) x 120(H) mm  
 16-9/16(W) x 16-3/16(D) x 4-11/16(H) in  
 Operating temperature.....+5 °C — +35 °C (41°F — 95°F)  
 Operating humidity.....5% — 90% (There should be no condensation of moisture.)

### 2. Disc LaserVision Discs

\*Maximum playing times  
 12-inch standard play disc.....1 hour/both sides  
 12-inch extended play disc.....2 hours/both sides  
 8-inch standard play disc.....28 min/both sides  
 8-inch extended play disc.....40 min/both sides

Spindle motor speed  
 Standard play disc.....1,800 rpm  
 Extended play disc  
 .....1,800 rpm (inner circumference)  
 to 600 rpm (outer circumference)  
 (For a 12-inch disc)

### Compact Discs

Disc.....Diameter: 120 mm, Thickness: 1.2 mm  
 Rotation direction (pickup side): Counterclockwise  
 Linear speed: 1.2 - 1.4 m/sec  
 \*Maximum playing time.....60 min. or more (For stereo playback)

*\*Actual playback time differs for each disc.*

### 3. Video characteristics

Format.....NTSC specifications

Video output  
 Level...1 Vp-p nominal, sync. negative, terminated  
 Impedance.....75 Ω unbalanced  
 Terminal.....RCA jack

VHF output  
 Channel.....Channel 3 or 4 (switchable)  
 Impedance.....75 Ω unbalanced  
 Terminal.....F-type jack

### 4. Audio characteristics

Output level  
 CD/LV OUT terminals  
 During analog audio output.....200 mVrms (1kHz, 40%)  
 During digital audio output.....200 mVrms (1kHz, -20dB)

LV ANALOG OUT terminals.....200 mVrms (1kHz, 40%)  
 (For LV analog audio output, 1/L, 2/R and stereo selections are possible)

Terminal.....Both RCA jacks  
 Number of channels.....2

### Digital Audio Characteristics

Frequency response	4 Hz - 20 kHz ( ±0.5 dB) (EIAJ)
S/N ratio	98 dB (EIAJ)
Dynamic range	95 dB (EIAJ)
Channel separation	92 dB (EIAJ)
Total harmonic distortion	0.005% (EIAJ)
Wow and flutter	Limit of measurement ( ±0.001% W.PEAK) or less (EIAJ)

● LV is based on EIAJ.

### 5. Other Terminals

Control input/output.....Both miniature jacks

### 6. Accessories

#### U.S. and Canadian models

Remote control unit (CU-CLD004).....1  
 Size "AAA" (IEC R03) dry cell battery.....2  
 RF antenna cable.....1  
 Video connecting cord.....1  
 Audio connecting cord.....1  
 Antenna adaptor (75 Ω/300 Ω → 75 Ω F-type plug).....1  
 Operating instructions.....1  
 Warranty card.....1

#### U.S. Military model

Remote control unit (CU-CLD004).....1  
 Size "AAA" (IEC R03) dry cell battery.....2  
 RF antenna cable.....1  
 Video connecting cord.....1  
 Audio connecting cord.....1  
 Antenna adaptor (75 Ω/300 Ω → 75 Ω F-type plug).....1  
 F-type jack — IEC plug adaptor.....1  
 Operating instructions.....1  
 Warranty card.....1

**7. Functions**

Function that can be operated with remote control unit (CU-CLD004)

Functions	LaserVision Disc		Compact Disc
	Standard Play Disc	Extended Play Disc	
PLAY	YES	YES	YES
EJECT	YES	YES	YES
TV/LVP SELECTION	YES	YES	YES
PAUSE	YES	YES	YES
AUTOMATIC PAUSE	YES	YES	YES
SCAN (Forward, Reverse)	YES	YES	YES
AUDIO CHANNEL SELECTION (Stereo, 1/L, 2/R)	YES	YES	—
AUTO DIGITAL/ANALOG SWITCH	YES(1)	YES(1)	—
CX SYSTEM ON/OFF	YES(2)	YES(2)	—
STILL/STEP (Forward, Reverse)	YES	NO	—
CHAPTER SKIP (Forward, Reverse)	YES(3)	YES(3)	—
MULTI-SPEED (Forward, Reverse: variable in 9 steps)	YES	NO	—
MULTI-SPEED DISPLAY	YES	NO	—
FRAME NUMBER DISPLAY	YES	NO	—
TIME NUMBER DISPLAY	NO	YES	—
CHAPTER NUMBER DISPLAY	YES(3)	YES(3)	—
FRAME NUMBER SEARCH	YES	NO	—
TIME NUMBER SEARCH	NO	YES	—
CHAPTER NUMBER SEARCH	YES(3)	YES(3)	—
CHAPTER REPEAT	YES(3)	YES(3)	—
A-B (INTERVAL) REPEAT	YES	YES	YES
MEMORY REPEAT	YES	YES	YES
SIDE REPEAT	YES	YES	YES
PROGRAM PLAYBACK	YES(3)	YES(3)	YES
PROGRAM DISPLAY	YES(3)	YES(3)	YES
PROGRAM REPEAT	YES(3)	YES(3)	YES
PROGRAM EDIT	YES(3)	YES(3)	YES
TRACK SEARCH (SKIP SELECTION)	—	—	YES
TIME SEARCH	—	—	YES
TRACK REPEAT	—	—	YES
TRACK NUMBER SEARCH (DIRECT SELECTION)	—	—	YES
TRACK.TIME DISPLAY	—	—	YES
REMAINING TIME DISPLAY	—	—	YES
TOTAL TRACKS.TOTAL TIME DISPLAY	—	—	YES

**NOTE:**

- (1) Can only be used with discs with digital sound tracks.
- (2) Valid for analog sound when playing a disc with the CX mark.
- (3) Possible for playback of disc on which chapter numbers are recorded.

**Other Functions**

- Automatic start (Possible for both CD and LV.)
- Automatic picture stop (LV: Possible only for discs on which picture stop codes are recorded.)

**NOTE:**

Specifications and design subject to possible modifications without notice, due to improvement.



### 3. PANEL FACILITIES

[REAR PANEL]

**ANTENNA terminal (75 Ω F-type jack)**  
Connect the coaxial cable (75 Ω) from the VHF TV antenna to this terminal.

**VHF OUT terminal (75 Ω F-type jack)**  
Connect this terminal to your TV set's VHF antenna terminal.

**VHF CHANNEL SELECTOR (CH3/CH4)**  
This switch is for switching the internal VHF converter.  
Set to the channel which is not used for TV broadcasts in your area.

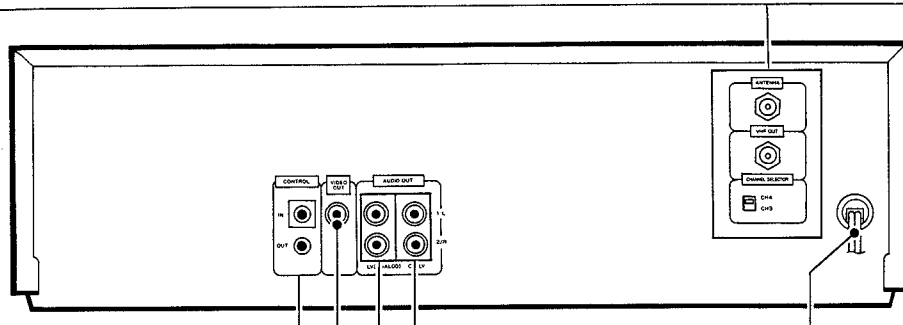

**Power cord**  
Connect this to a power outlet.

**CONTROL IN and OUT terminals (miniature phone jack)**  
These terminals are for communication of control codes, when the player is used together with other Pioneer products with the Pioneer mark.

**VIDEO OUT terminal (RCA jack)**  
Connect this jack to a TV monitor or a TV set which is provided with a video input terminal.

**LV (ANALOG) AUDIO OUT terminals (RCA jacks)**  
These terminals output the analog audio only of LaserVision Discs. Connect them to the AUX input terminals etc. of your stereo amplifier. Do not connect these terminals to your amplifier PHONO input.  
These terminals do not output the digital sound from Compact Discs or LaserVision with Digital Sound Discs.

**CD/LV AUDIO OUT terminals (RCA jacks)**  
These terminals output Compact Disc audio, LaserVision Disc audio (analog) and the audio for LaserVision with Digital Sound Discs. Selection of either digital or analog sound can be made by operating a button on the front panel.  
Connect these terminals to the CD or AUX input terminals etc. of your stereo amplifier. Do not connect them to your amplifier PHONO input.

**ABOUT THE AUDIO OUTPUT TERMINALS**  
This player is equipped with two sets of audio output terminals.  
As shown in the table below, the CD/LV terminals are able to output all the audio signals that can be played back by the player.

Type of Disc	Playback Sound	Output Terminals
Compact Disc	Digital	CD/LV
LaserVision with Digital Sound Discs (Discs with the <i>digital SOUND</i> mark)	Digital	CD/LV ←
	Analog	CD/LV ← LV (Analog)
LaserVision Discs (Discs without the <i>digital SOUND</i> mark)	Analog	CD/LV LV (ANALOG)

Can be selected with the AUTO DIGITAL/ANALOG key on the remote control unit.

**For ordinary operation, connect the CD/LV terminals to your amplifier.**  
The LV (ANALOG) terminals are provided for developmental use. They do not need to be used for ordinary operation.

**NOTE:**  
The sound output from the VHF output terminal is analog sound. When a TV set is connected to the VHF output terminal, it cannot be used to listen to Compact Disc sound, or to the digitally recorded sound on LaserVision with Digital Sound Discs.

**[PLAYER FRONT PANEL]**

**DOOR**

When power is switched on, and OPEN/CLOSE button is pressed, the door opens downward, and at the same time, the disc table is expelled outward a specified distance.

**POWER button and indicator**

**OPEN/CLOSE (  ) button**

This button is used to open and close the disc table. Setting a disc on the disc table then pressing this button retracts the disc table in to the player and begins play of the disc. Pressing this button during play stops play and extends the table from the player.

**REMOTE SENSOR window**

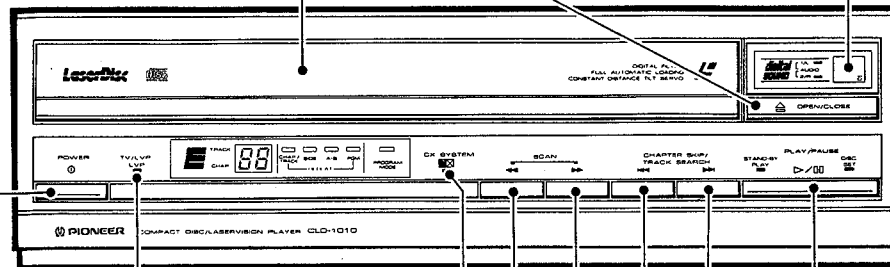

**TV/LVP indicator**

This indicates whether the pictures on the TV connected to the rear panel VHF OUT terminal, are being played back from the disc or received from the TV broadcasting station.

- ON : LaserVision Disc or Compact Disc playback
- OFF : VHF TV broadcast reception



After switching on power the indicator is ON, indicating selection of disc playback.

**CX SYSTEM indicator  
(For LaserVision Disc playback only)**



Lights when the CX noise reduction system is operating.

CX is a trademark of CBS Inc.  
This player meets the CX EXPANDING SPECIFICATION.

**SCAN (  ,  ) buttons**

After play has begun, the disc is fast forwarded as long as the  button is held down or fast backwarded as long as the  button is held down. There are two speeds. The first two seconds while one of the scan buttons is held down the scanning is at low speed, then it is at high speed.

**CHAPTER SKIP/TRACK SEARCH (  ,  ) buttons**

- This is used to move to the head of the chapter for a LaserVision disc or the head of the track for a compact disc.
- Pressing the  button during entry of a program for programmed play cancels the last number input. Pressing this button again cancels the number entered before that. Each time this button is pressed, the last number still retained is cancelled (edit function). The  button has no effect during program input.

**PLAY/PAUSE (  /  ) button**

- Setting a disc on the disc table then pressing this button retracts the disc table into the player, and begins play of the disc.
- Pressing this button while the disc is stopped begins play of the disc.
- Pressing this button during play pauses the play. Pressing this button again restarts the play from the point at which it was paused.
- Press this button to begin chapter programming.

**PROGRAM MODE indicator**

Shows that the player is in program playback mode.

**Numeric display**

- When playing back a LaserVision Disc, displays the "chapter" number presently being played back.
- When playing back a Compact Disc, displays the "track" number presently being played back.

**COMPACT DISC (CD) indicator**

Lights during Compact Disc playback mode.

**LASERVISION DISC (LV) indicator**

Lights during LaserVision Disc playback mode.

**DIGITAL SOUND indicator**

Lights at the following times to indicate that audio signal output from the CD/LV audio terminal on the rear panel is digitally recorded sound:

- During Compact Disc playback.
- During playback of a LaserVision with Digital Sound Disc.

**AUDIO indicators**

**(For LaserVision Disc playback only)**

These indicate the audio channels being played back. When power is switched on, both 1/L and 2/R light up, indicating stereo mode.

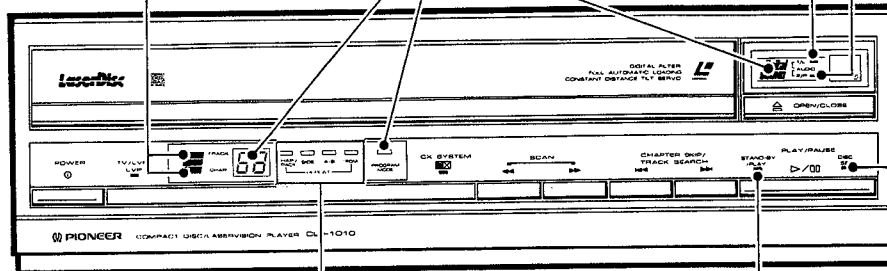

**CHAP./TRACK REPEAT indicator**

- During playback of a LaserVision Disc, lights when chapter repeat playback is selected.
- During playback of a Compact Disc, lights when track repeat playback is selected.

**SIDE REPEAT indicator**

Lights when repeat play of one side of a disc is selected.

**A-B REPEAT indicator**

Lights when repeat play of an interval between two points A and B is selected.

**PROGRAM REPEAT indicator**

This indicator shows that the player is in program repeat play mode.

**STAND-BY/PLAY indicator**

This indicator lights up when the disc is being played and blinks during stand-by.

Lights up: during play mode (normal playback)  
Blinks:

- From the time the PLAY key is pressed until the playback actually begins.
- After the playback is over until the disc stops.
- During the time that the table is extended from the player for removing or changing the disc. This indicator also blinks during operations such as search and skip.

**DISC SET indicator**

Lights up when there is a disc in the player.

**[REMOTE CONTROL UNIT]**

The accessory remote control unit can be used during playback of both LaserVision discs and Compact Discs.

- The functions shown in black are used for LaserVision Discs only.
- The functions shown in green are used for Compact Discs only.

Keys appearing in other colors have the same functions for both kinds of disc.

**TV/LVP key**

When the VHF antenna is connected to the TV set via the player, this key switches between disc playback and VHF TV broadcast reception.

**AUTO DIGITAL/ANALOG key**

Pressing this key selects the audio output from the CD/LV audio output terminals on the back of the player during playback of a LaserVision disc with digital audio.

This key has no effect for playback of compact discs or LaserVision discs without digital audio.

**CX key**

This is the on/off key for the CX noise reduction system.

**AUDIO MONITOR key**

Switches the audio channel. When the player is first turned on, the audio is stereo and the 1/L and 2/R AUDIO indicators are both lit up. Each time this key is pressed, the audio channel moves one step through the sequence: 1/L → 2/R → Stereo → 1/L ...

**EJECT (■/▲) key**

This key is used to stop playback and remove the disc.

The first time this key is pressed stops the rotation of the disc. The second time this key is pressed extends the disc table from the player. If there is no disc on the disc table, the disc table is extended out from the player the first time this key is pressed.

**REPEAT (A, B) keys**

These are used for repeat playback.

**DIGIT (0 - 9) keys**

**SEARCH/MEMORY key**

This is used for:

- Execution of search operation.
- For memory repeat operation. (Memory key function)

This key is also used to input programs for programmed play.

**DISPLAY key**

- For a LaserVision disc, the display key is used for displaying or erasing the screen display of the chapter or frame being played or the time during playback of a LaserVision disc.

- When a compact disc is played, each time this key is pressed, the display on the screen will change to show the REMAIN time, the TOTAL time, the TIME, and back to the REMAIN time respectively.

**CHAPTER/FRAME·TIME, TIME key**

This key is used to call up the part of the disc that you wish to see or listen to (search).

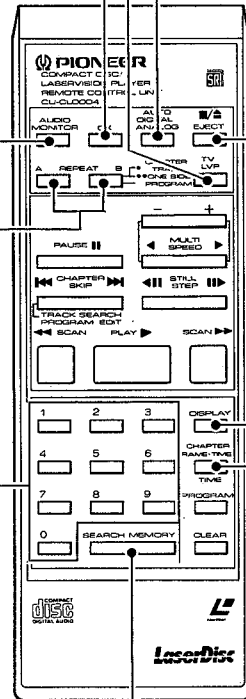

**PAUSE (||) key**

When this is pressed, the playback is temporarily interrupted. To release the pause mode, press the PAUSE key again.

**CHAPTER SKIP/TRACK SEARCH (◀◀, ▶▶), PROGRAM EDIT (◀◀) key**

This key has the same functions as the CHAPTER SKIP/TRACK SEARCH button on the front of the player.

**SCAN (◀◀, ▶▶) key**

This is used for fast forward and fast backward playback.

**PLAY (▶) key**

- Setting a disc on the disc table then pressing this key retracts the disc table into the player and begins play of the disc.
- Pressing this key when the disc is stopped starts playback.
- Pressing this key when player is paused restarts normal playback.
- Pressing this key after chapter programming starts play for that chapter program.

**PROGRAM key**

This key is used for programmed playback, which is playback in which the order of chapters for a LaserVision disc or the order of tracks for a compact disc is changed.

**◻, ◻ key**

This key is used for setting the speed for multi-speed playback.

**MULTI-SPEED (◀, ▶) key (LaserVision disc)**

- Pressing the ▶ side of this key during playback of a standard disc plays back the disc in the forward direction at the preset speed. Pressing the ◀ side of this key during playback of a standard disc plays back the disc in the reverse direction at the preset speed (with no audio). The speed is set with the -, + key.
- This key has no effect for extended play discs and "CLV" is displayed on the screen.

**STILL/STEP (◀◻, ◻▶) key (LaserVision disc)**

- Pressing either end of this key causes still frame playback. Then, pressing the ◻▶ side of this key advances the playback one frame, while pressing the ◀◻ side of this key reverse the playback one frame.
- This key has no effect for extended play discs and "CLV" is displayed on the screen.

**CLEAR key**

The CLEAR key is used in the following cases:

- To stop repeat playback, to interrupt a search, or to correct input made with the DIGIT keys. (Pressing the CLEAR key and holding it down ends numeric input mode itself.)
- To erase the last step of the program. (Pressing the CLEAR key and holding it down ends program input mode itself.)
- To end program playback.

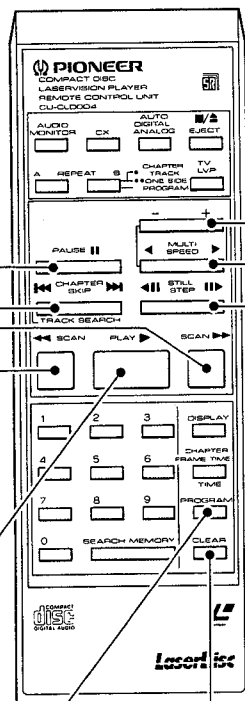

# 4. DISASSEMBLY

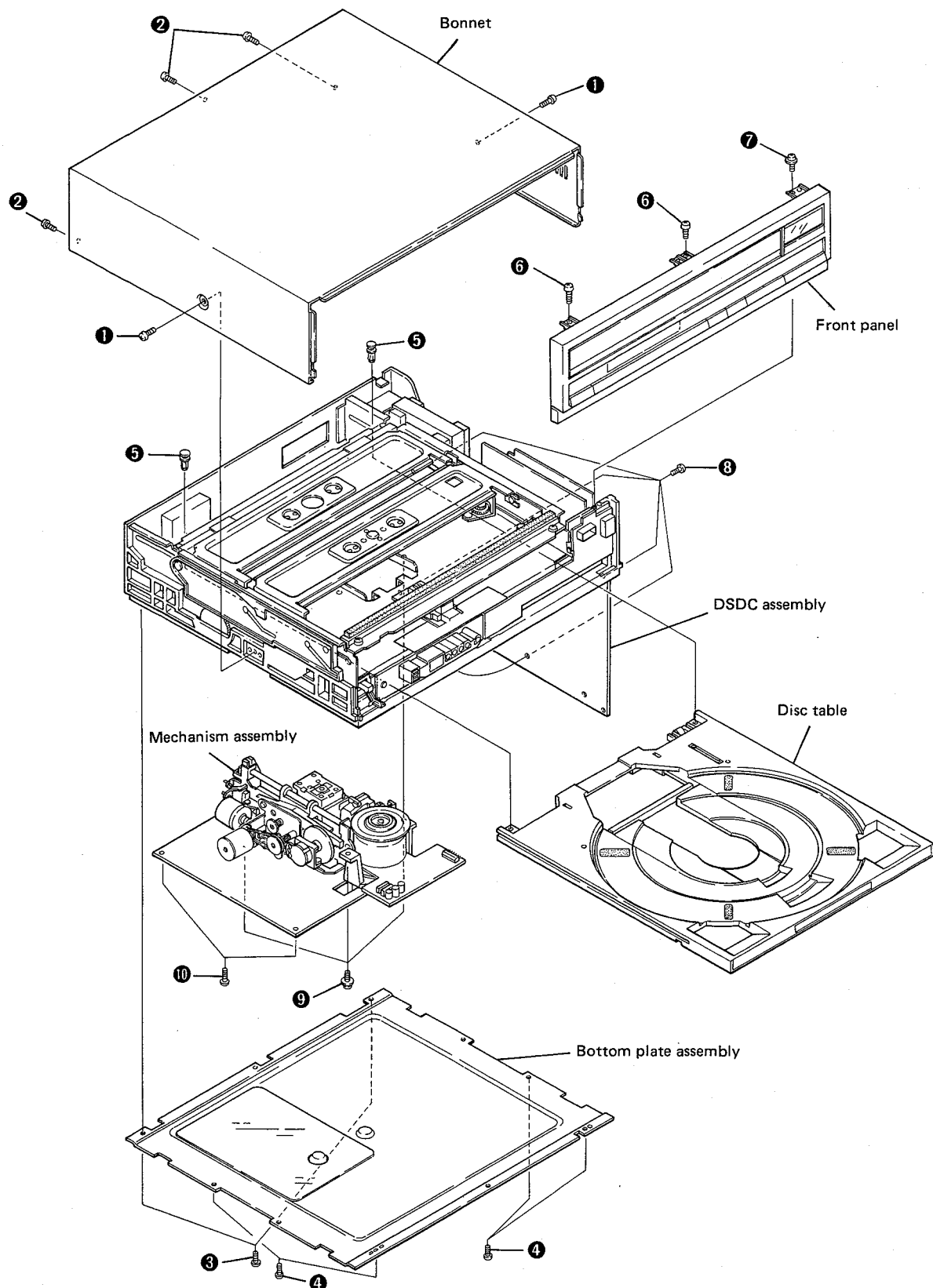

- **Disassembly Procedure**

**[Bonnet]**

1. Remove the two screws ❶ on the side.
2. Remove the three screws ❷ on the rear.

**[Bottom Plate]**

1. Remove the two screws ❸.
2. Remove the four screws ❹.

**[Disc Table]**

1. Remove the bonnet.
2. Switch on the power, press the OPEN/CLOSE key ( ▲ ), then with the disc table up, switch off the power.
3. Remove the two rivets ❺.
4. Switch the power back on. When the disc table is fully extended, pull it away gently.

**[Front Panel]**

1. Remove the bonnet.
2. Remove the two screws ❻ and a screw ❼.

**[Mechanical Assembly]**

1. Remove the four screws ❽, then raise the DSDC assembly.
2. Remove the three screws ❾ and remove the two screws ❿.

Note: The details on how to replace the Pick-up assembly will be found on Page 68.

# 5. EXPLODED VIEWS AND PARTS LIST

## 5.1 EXTERIOR AND FRONT VIEW

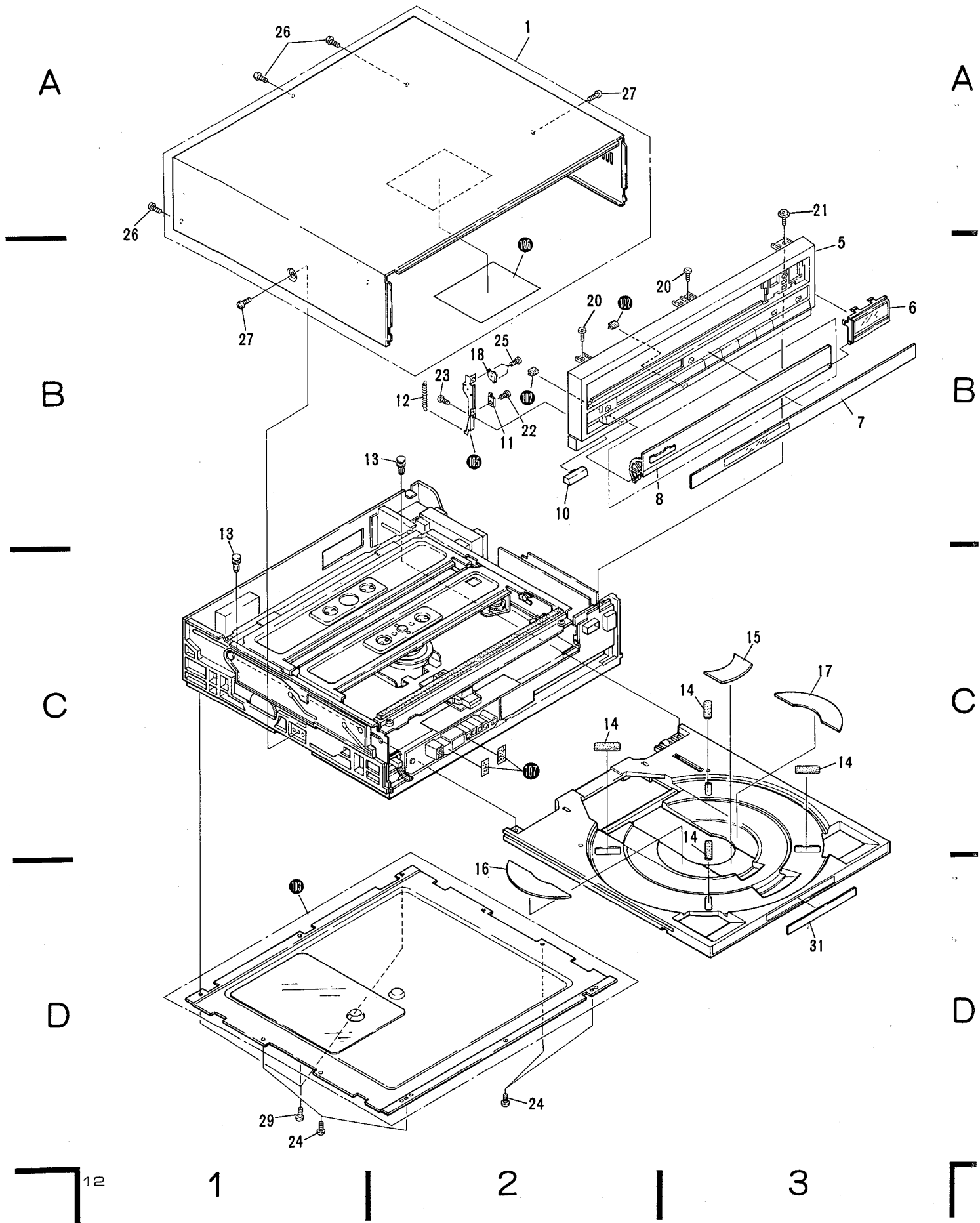



**NOTES:**

- Parts without part number cannot be supplied.
- The  $\Delta$  mark found on some component parts indicates the importance of the safety factor of the part. Therefore, when replacing, be sure to use parts of identical designation.
- For your parts Stock Control, the fast moving items are indicated with the marks **★★** and **★**.  
**★★ GENERALLY MOVES FASTER THAN ★**  
 This classification shall be adjusted by each distributor because it depends on model number, temperature, humidity, etc.
- Parts marked by "⊙" are not always kept in stock. Their delivery time may be longer than usual or they may be unavailable.

**● Parts List of Exterior and Front View**

Mark	No.	Part No.	Description	Mark	No.	Part No.	Description
	1.	VXA1054	Bonnet assembly		21.	AMZ30P080FUC	Screw
	2.	...	...		22.	AMZ20P080FMC	Screw
	3.	...	...		23.	BPZ30P060FUC	Screw
	4.	...	...		24.	BPZ30P080FCU	Screw
	5.	VXX1041	Front panel assembly-S		25.	AMZ20P080FMC	Screw
	6.	VXX1028	Indicator panel assembly		26.	BBT30P060FZK	Screw
	7.	VNK1078	Display Panel		27.	BMZ40P100FZK	Screw
	8.	VXX1049	Front door assembly		28.	...	...
	9.	...	...		29.	BBZ30P060FCU	Screw
	10.	VNK1071	Power button		30.	...	...
	11.	VSK-012	Door switch		31.	VRW1015	Caddy label
	12.	VBH1010	Door spring		101.	...	...
	13.	VEC-261	Plastic rivet		102.	...	Cushion
	14.	VEC-273	Disc Pad		103.	...	Bottom board assembly
	15.	VEB1021	Sheet (F)		104.	...	...
	16.	VEB1022	Sheet (L)		105.	...	SW holder
	17.	VEB1023	Sheet (R)		106.	...	Black sheet
	18.	VXA1053	Dumper assembly		107.	...	Cushion
	19.	...	...				
	20.	ABZ30P060FUC	Screw				

CLD-1010

1

2

3

5.2 TOP VIEW

A

A

B

B

C

C

D

D

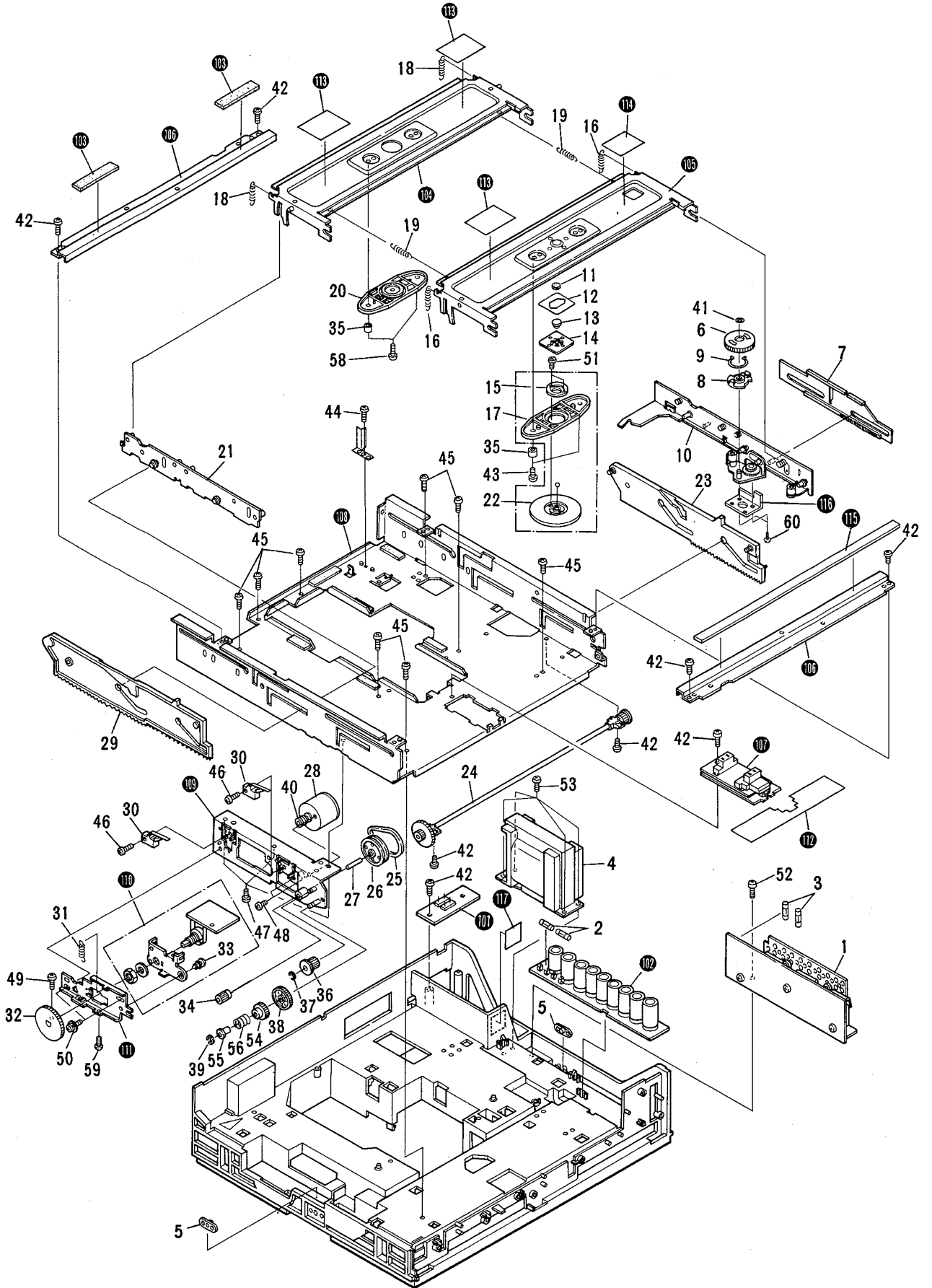

● Parts List of Top View

Mark	No.	Part No.	Description	Mark	No.	Part No.	Description
	1.	VYR1019	REGB assembly		41.	WT36D070D025	Washer
△ ★ ★	2.	VEK-018	Fuse (3A) (FU103, FU104)		42.	BBZ30P080FCU	Screw
△ ★ ★	3.	VEK-022	Fuse (2A) (FU1, FU2)		43.	PMB30P060FCU	Screw
△ ★	4.	VTT-078	Power transformer (T1)		44.	BMZ20P080FMC	Screw
	5.	VBN-005	Welding nut		45.	BPZ30P080FCU	Screw
	6.	VNL1029	Gear (E)		46.	BM20P080FMC	Screw
	7.	VNL1024	Rack		47.	BBZ30P060FCU	Screw
	8.	VNL1030	Pinion (E)		48.	PMB26P040FMC	Screw
	9.	VBH1007	Gear spring		49.	BPZ30P060FMC	Screw
	10.	VXA1063	Roller plate (R) assembly		50.	PMB30P060FCU	Screw
	11.	VEB-129	Rubber sheet		51.	PPZ20P050FMC	Screw
	12.	VEC-262	Holder securing tape		52.	BPZ30P080FCU	Screw
	13.	VLL1018	Ball holder		53.	BPZ30P100FCU	Screw
	14.	VNE-689	Holder		54.	VNL1046	W Gear (B)
	15.	VNL-500	Clamper head		55.	VLL1039	W Gear (A) shaft
	16.	VBH-162	LD clamper spring		56.	VBH1017	W Gear spring
	17.	VNL-612	Clamper base		57.	...	...
	18.	VBH-179	CD clamper spring		58.	PMB30P055FZK	Screw
	19.	VBH-177	Holder spring		59.	PMZ30P080FMC	Screw
	20.	VXA1067	CD disc clamper assembly		60.	BBZ20P040FMC	Screw
	21.	VXA1062	Roller plate (L) assembly	△	101.		CNNB assembly
	22.	VNL-588	Disc clamper		102.		CAPB assembly
	23.	VNL-583	Rack gear (R)		103.		Rubber cushion
	24.	VXA1028	Synchronized gear assembly		104.		Clamper holder assembly
	25.	VEB-125	Synchronized belt (L)		105.		Clamper holder
	26.	VXA-477	Pulley (L) assembly		106.		Bridge
	27.	VLL1020	Gear (A) shaft		107.		SENS assembly
★ ★	28.	VXM1006	Loading motor (M6)		108.		Sub chassis
	29.	VNL-582	Rack gear (L)		109.		M holder assembly
★ ★	30.	VSK-010	Slide switch (S6, S7) (CD, LD misclamp)		110.		CALB assembly
	31.	VBH-161	RE spring		111.		RE holder
	32.	VNL1036	Potention gear		112.		Black sheet
	33.	VEC-143	Plastic rivet		113.		Dump cushion (K)
	34.	VNL1020	Gear (A)		114.		Dump cushion (L)
	35.	VLL-345	Spacer		115.		Cushion
	36.	VNL1047	Gear (C)		116.		Rack holder
	37.	YE30FNC	E ring		117.		Fuse caution label
	38.	VNL1045	W Gear (A)				
	39.	YE20FUC	E ring				
	40.	VNL1051	Motor pulley				

CLD-1010

1

2

3

5.3 BOTTOM VIEW

A

B

C

D

A

B

C

D

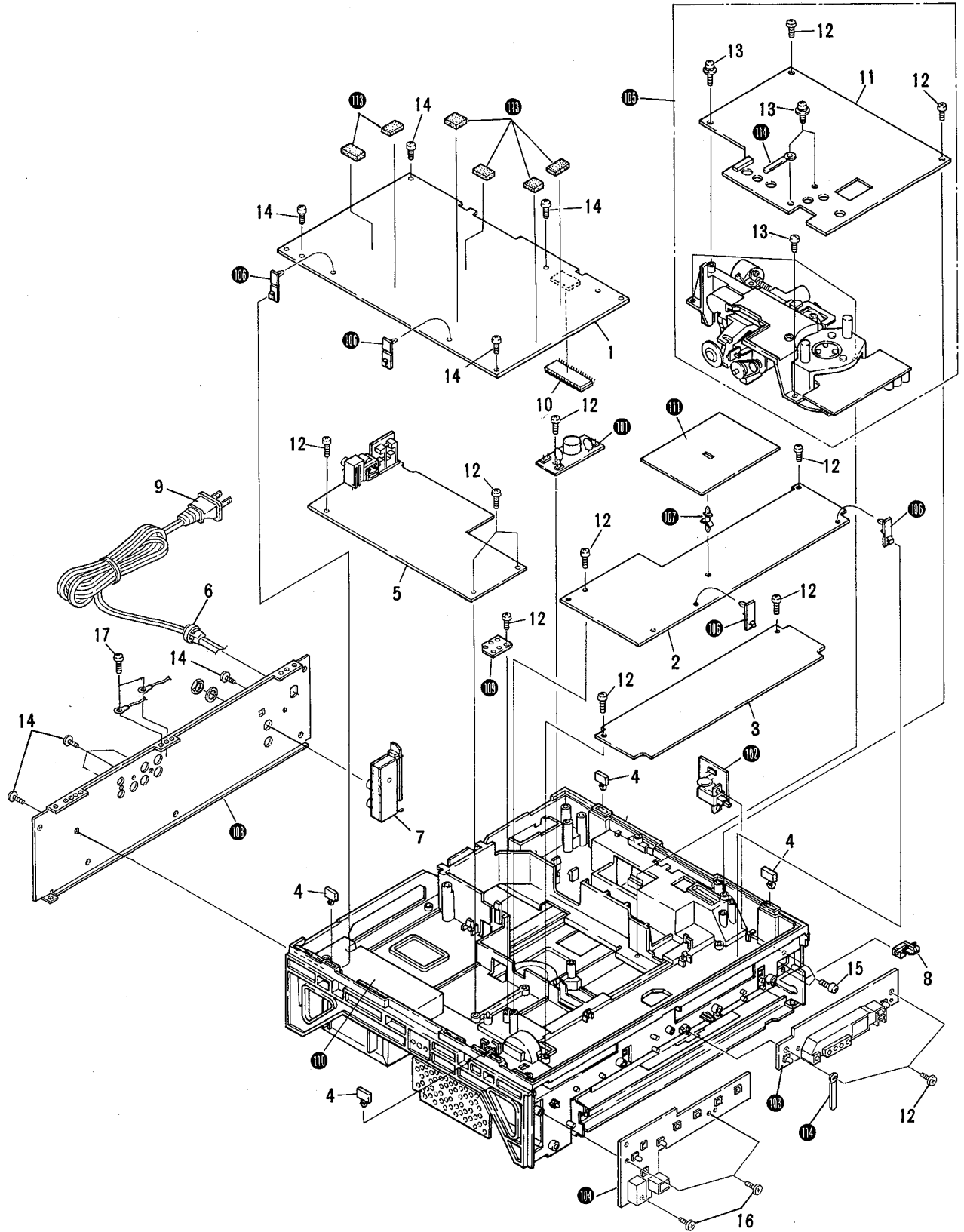

16

1

2

3

● Parts List of Bottom View

Mark	No.	Part No.	Description	Mark	No.	Part No.	Description
	1.	VWG1010	DSDC assembly	△	101.		LSFB assembly
	2.	VYV1013	STBC assembly	△	102.		PWSB assembly
	3.	VYV1007	VDEM assembly		103.		DISP assembly
	4.	VEB1001	Rubber foot		104.		KEYB assembly
	5.	VYV1015	ADEM assembly		105.		Mechanism assembly
△	6.	CM-22C	Cord stoper		106.		P.C. B hinge
	7.	VYV1016	MODB assembly		107.		PC support
	8.	VNK1058	SW joint		108.		Rear panel
△	9.	VDG-038	AC Power cord		109.		Earth plate
★ ★	10.	VYW1029	EP ROM (IC111)		110.		Base
	11.	VYS1003	SRVB assembly		111.		Shield sheet
	12.	BPZ30P080FCU	Screw		112.		...
	13.	PMB30P080FCU	Screw		113.		P.C.B cushion
	14.	BPZ30P080FZK	Screw		114.		Cord clasper
	15.	PMB30P080FCU	Screw				
	16.	BPZ30P030FCU	Screw				
	17.	BBZ30P060FCU	Screw				

5.4 MECHANISM ASSEMBLY VIEW

A

A

B

B

C

C

D

D

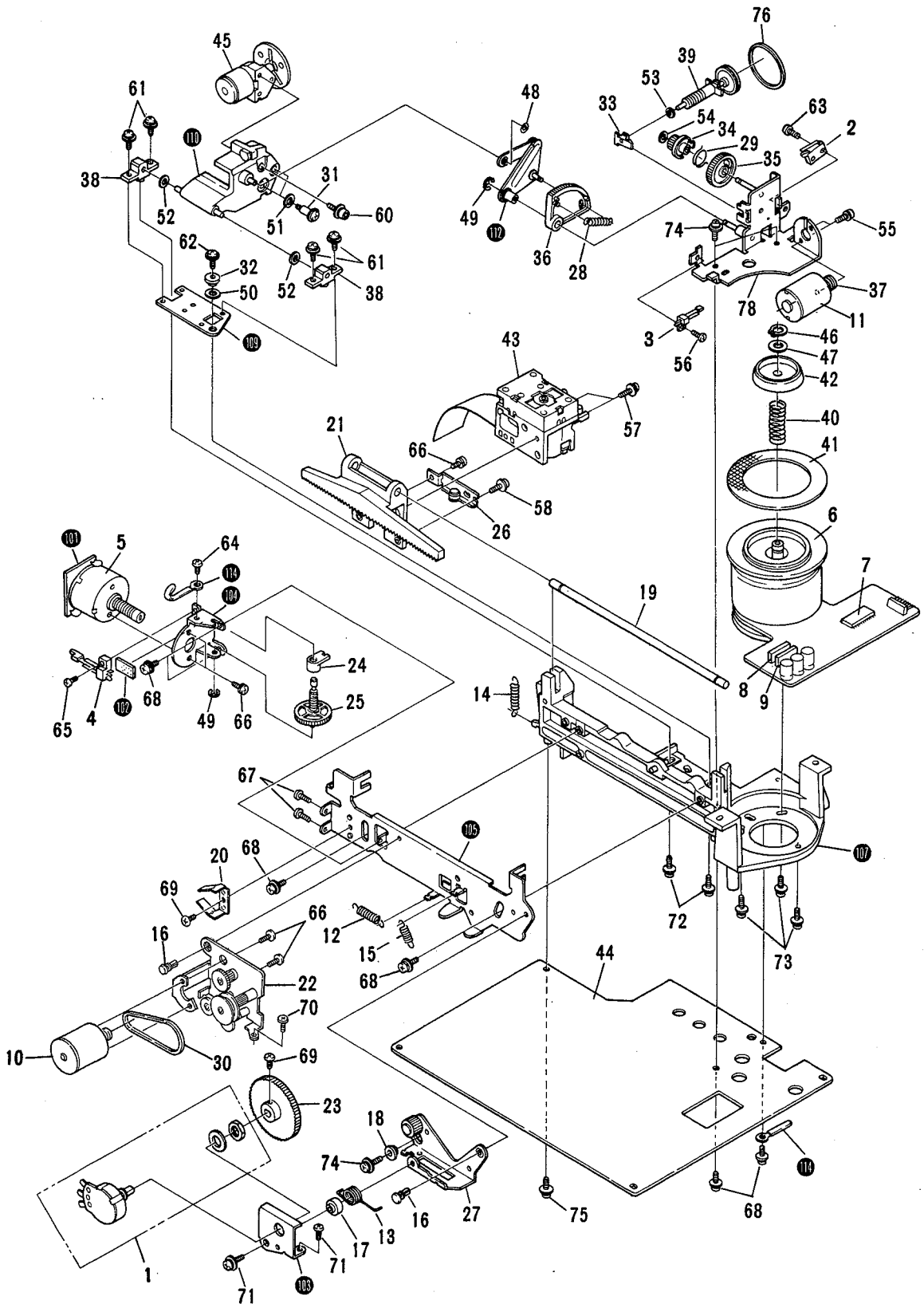

## ● Parts List of Mechanism View

Mark	No.	Part No.	Description	Mark	No.	Part No.	Description
★	1.	VCS-017	Potential meter (VR1)	43.	VWY1010	Pick-up assembly	
★★	2.	VSK-010	Slide switch (CD MOTOR RELEASE) (S5)	44.	VYS1003	SRVB assembly	
★★	3.	VSK-014	Leaf switch (CD MOTOR SET) (S4)	45.	VXX1047	Spindle motor assembly (CD, M2)	
★★	4.	VSK-015 (PSN-003)	Leaf switch (TILT LIMIT) (S3)	46.	YC60RBT	Washer	
★★	5.	VXM-060	Tilt motor (M4)	47.	WA62N120W020	Washer	
★★	6.	VXM-063 (VXM-065)	Spindle motor (LD, M1)	48.	WT21D050D050	Washer	
★★	7.	PA2016	Control IC (IC1) (LD SPINDLE MOTOR)	49.	YE20FUC	E ring	
★★	8.	STA302A	Transistor array (Q10) (LD SPINDLE MOTOR)	50.	VEF-023	Spring (5φ)	
★★	9.	STA303A	Transistor array (Q11) (LD SPINDLE MOTOR)	51.	VEF-027	Spring (4φ)	
★★	10.	VXM-054	LOAD motor (for SLDR) (M3)	52.	WA31D054D050	Washer	
★★	11.	VXM1007	Swing motor (M5)	53.	WA21D040D025	Washer	
	12.	VBH-138	Slider motor spring	54.	WT34D060D050	Washer	
	13.	VBH-140	Torsion spring	55.	AMZ20P030FMC	Screw	
	14.	VBH-142	Tilt spring	56.	PMZ20P040FMC	Screw	
	15.	VBH1011	Potential meter spring	57.	PMB26P060FMC	Screw	
	16.	VEC-143	Plastic rivet	58.	AMZ26P070FMC	Screw	
	17.	VLL-310	PM nut	59.	...	...	
	18.	VLL-311	Nut	60.	VLL-378	Screw	
	19.	VLL1032	Carriage shaft	61.	AM30P050FCU	Screw	
	20.	VNE-701	Switch adjustment board	62.	AMZ30P080FMC	Screw	
	21.	VNL-598	Slider	63.	BMZ20P080FCU	Screw	
	22.	VXA1071	Gear box assembly	64.	BBZ30P060FCU	Screw	
	23.	VNL1036	Potential gear	65.	PMZ20P050FMC	Screw	
	24.	VNV-036	Tilt nut	66.	PMA26P040FCU	Screw	
	25.	VXA-387	Tilt shaft assembly	67.	PMZ30P160FMC	Screw	
	26.	VXA-394	Roller arm assembly	68.	PMB30P080FCU	Screw	
	27.	VXA-418	PM holder assembly	69.	BBZ30P060FMC	Screw	
	28.	VBH-166	Gear spring	70.	PMZ30P060FMC	Screw	
	29.	VBH-167	Pinion spring	71.	PMB30P100FCU	Screw	
	30.	VEB1024	Belt	72.	VLL-377	Screw	
	31.	VLL-183	Screw	73.	VLL-378	Screw	
	32.	VLL-371	Color	74.	PMB30P060FCU	Screw	
	33.	VNL-291	Shaft holder	75.	BMZ30P060FMC	Screw	
	34.	VNL-615	Pinion (A)	76.	VEB-126	Synchronized belt S	
	35.	VNL-616	Pinion (B)	77.	...	...	
	36.	VNL-617	Arm gear	78.	VXA-415	Base assembly	
	37.	VNL-635	Motor pulley	101.		TIMB assembly	
	38.	VNV-039	Holder	102.		Insulator bushing	
	39.	VXA-471	Worm gear assembly	103.		PB support	
	40.	VBH-141	Centering spring	104.		Tilt holder	
	41.	VEB1008	Rubber spacer	105.		Tilt base	
	42.	VNV-037	Centering hub	106.		...	
				107.		Mechanism chassis	
				108.		...	
				109.		Slide plate	
				110.		Motor base	
				111.		...	
				112.		Arm assembly	
				113.		...	
				114.		Cord clasper	

**CLD-1010**

**5.5 CARRY ASSEMBLY VIEW**

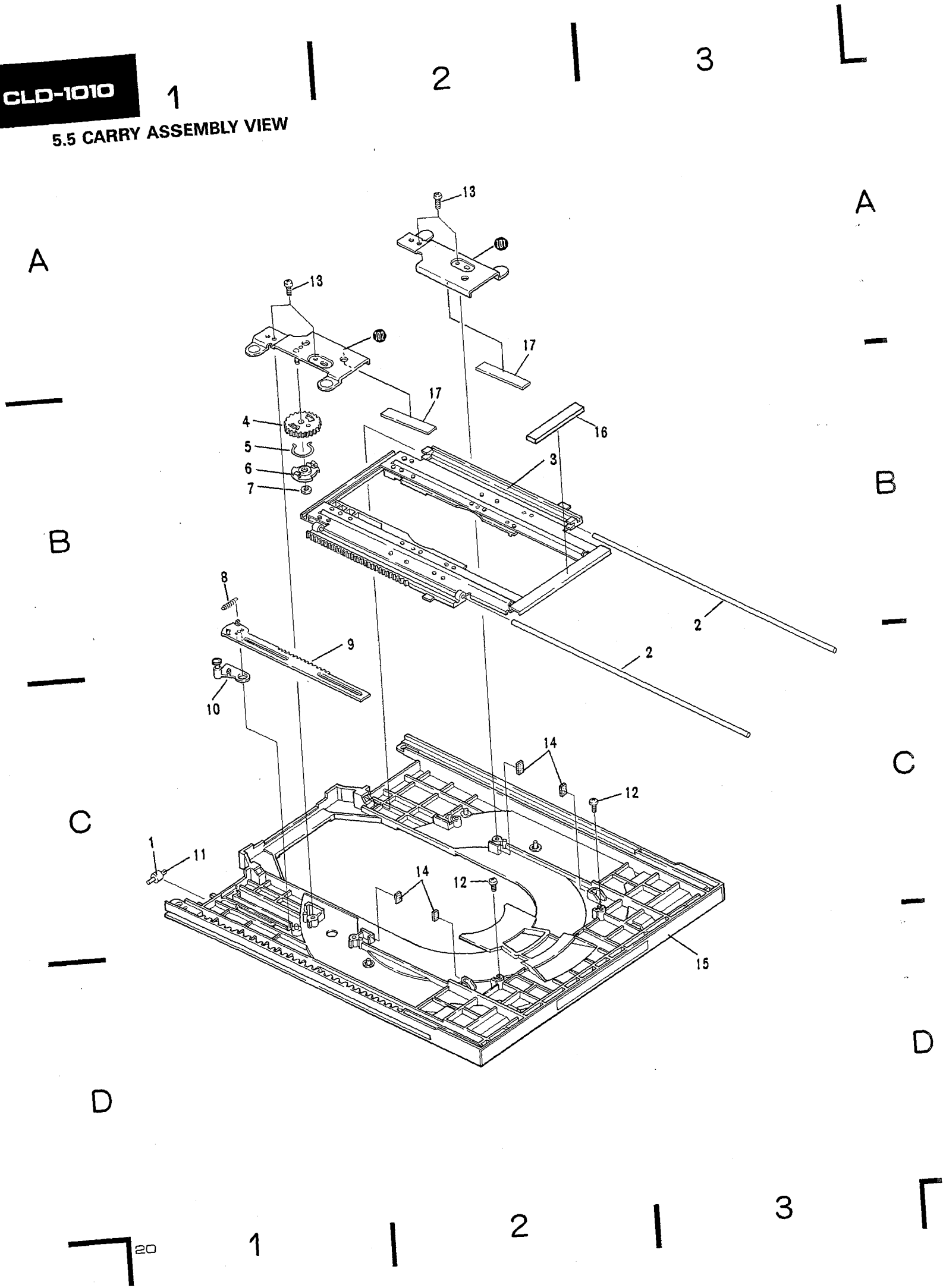



● Parts List of Carry Assembly

Mark	No.	Part No.	Description
	1.	VNL-597	Roller
	2.	VLL-356	Shaft
	3.	VXA-463	Sub-carry assembly
	4.	VNL-594	Gear (C)
	5.	VBH1016	Gear spring
	6.	VNL-595	Gear (D)
	7.	WT31D054D025	Polyslider washer
	8.	VBH1008	Lock plate spring
	9.	VNL1025	Slide plate
	10.	VXA1081	Lock plate assembly
	11.	VLL1025	Pin
	12.	ABZ30P080FCU	Screw
	13.	BBZ30P080FCU	Screw
	14.	VEC-272	Carry cushion
	15.	VXX1027	Carry assembly-S
	16.	VEC1054	*Black sheet (C)
	17.	VEC-286	Cushion F
	101.		Gear base (L)
	102.		Gear base (R) assembly

\* Note: Always install this sheet when replacing the Subcarrier assembly  
(in order to prevent erroneous disc detection).

CLD-1010

1

2

3

5.6 PICK-UP ASSEMBLY VIEW

A

A

B

B

C

C

D

D

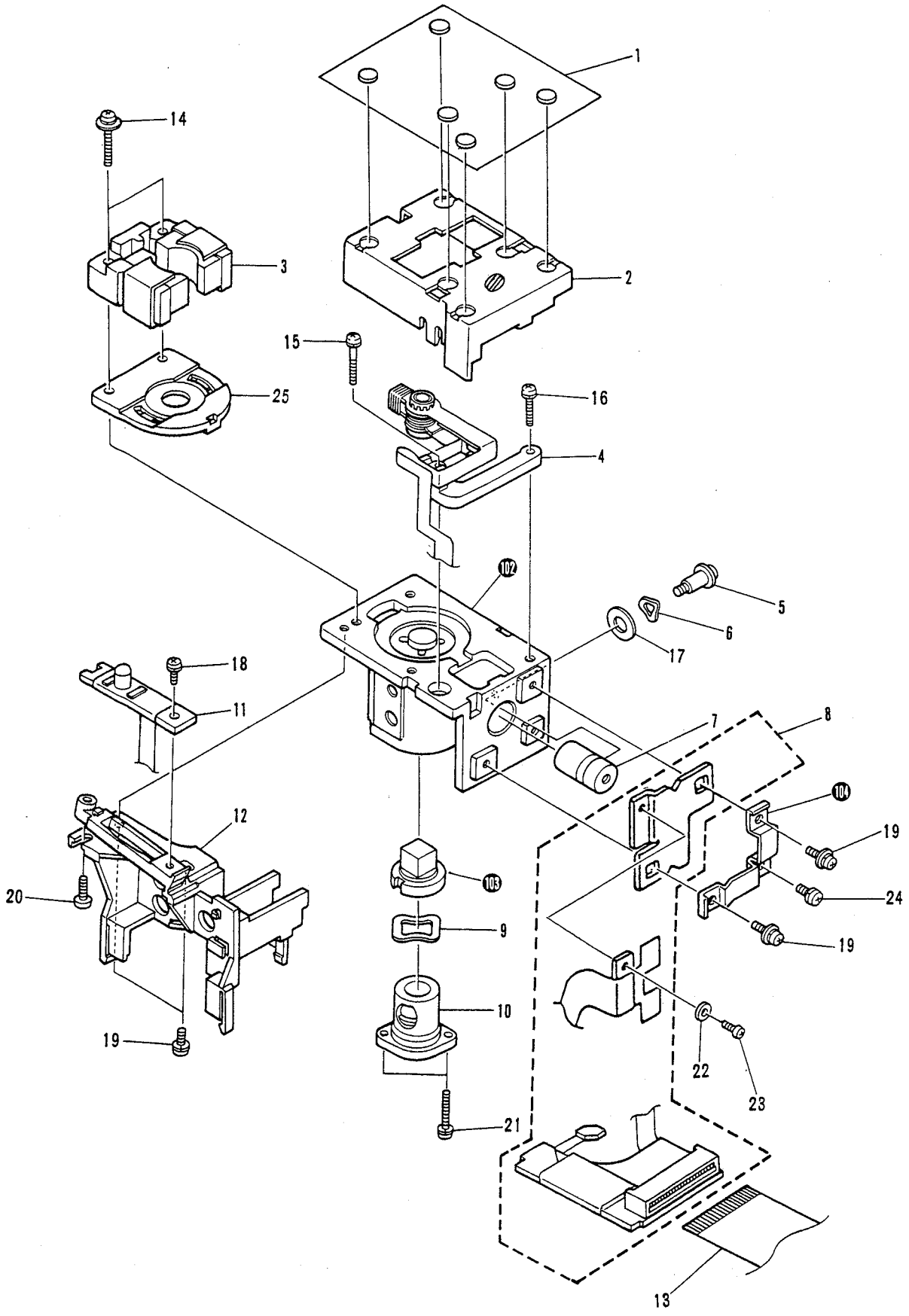

● Parts List of Pick-up Assembly

Mark	No.	Part No.	Description	Mark	No.	Part No.	Description
	1.	VED-034	Pad		16.	PMA20P080FMC	Screw
	2.	VNH-057	Actuator cover		17.	WA40100M050	Washer
	3.	VGX-071	Magnetic circuit assembly		18.	PPZ20P050FMC	Screw
	4.	VGX-069	Objective lens assembly		19.	PMB20P050FMC	Screw
	5.	VLL-292	Screw 5		20.	PBZ20P080FMC	Screw
	6.	PBE-020	Wave washer (4)		21.	PMA26P080FMC	Screw
	7.	VGX-064	Multi lens assembly		22.	WA20W050R050	Washer
	8.	VGX1002	PD-HEAD assembly		23.	PMA20P040FMC	Screw
	9.	PBE-022	Wave washer (8)		24.	PMA26P060FMC	Screw
	10.	VGX1001	LD assembly		25.	VGX1005	Wavelength plate assembly
	11.	VEX1001-A	Sensor assembly	102.			Optical body
	12.	VNH-056	Sensor stay	103.			Prism assembly
	13.	VDA-108	Fuji card	104.			PD spring N
	14.	PBM20P120FMC	Screw				
	15.	PMA20P140FMC	Screw				

**INSTALLING THE HEAD ASSEMBLY**

In order to make sure that flexible parts are supported in such a way that they lie flat, use the following procedure to install the PD-head assembly.

1. Use glue and double-sided tape folded in the manner indicated by the arrow in Figure 1 to install the PD-head assembly.
2. With the flexible part bent as shown in Figure 1, install it on the Pick-up.
3. Solder the flexible circuit board that connects the TRKG and FOCS coils and the disc tilt detection board on the Head assembly as shown in Fig. 2.

**Note:**

The copper foil on the flexible circuit board can not withstand heat very well, so solder as quickly as possible. Touch the soldering iron to the Head assembly, not to the flexible circuit board.

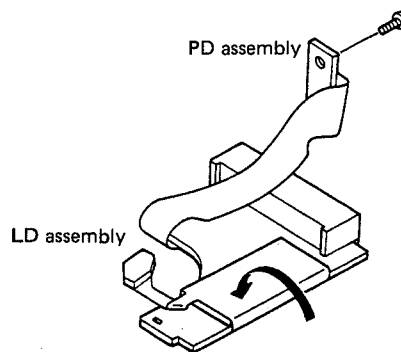

Fig. 1

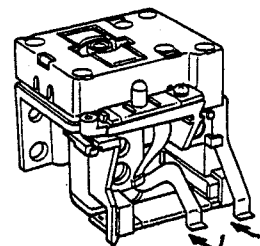
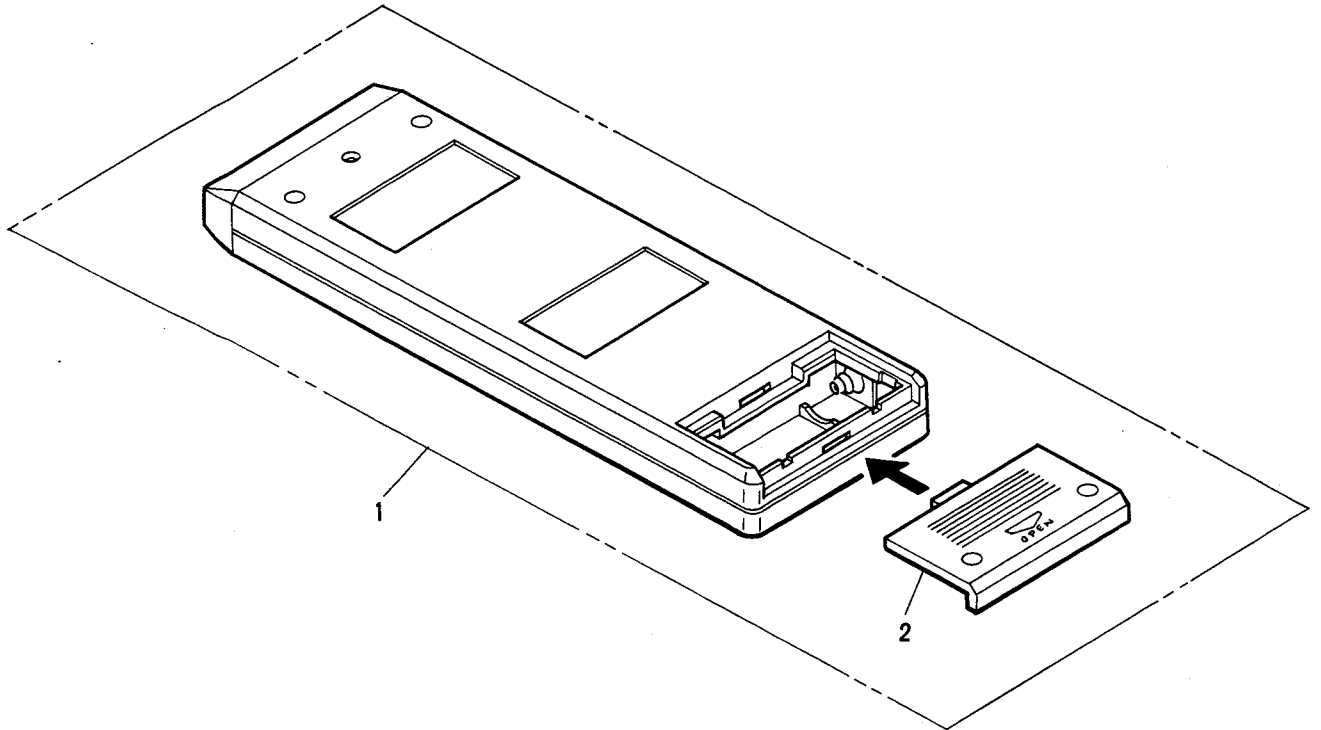

Fig. 2

**5.7 REMOTE CONTROL UNIT**



● **Parts List of Remote control unit**

<b>Mark</b>	<b>No.</b>	<b>Part No.</b>	<b>Description</b>
	1.	VXX1040	Remote control unit
	2.	VNK-548	Cover

## 6. PACKING

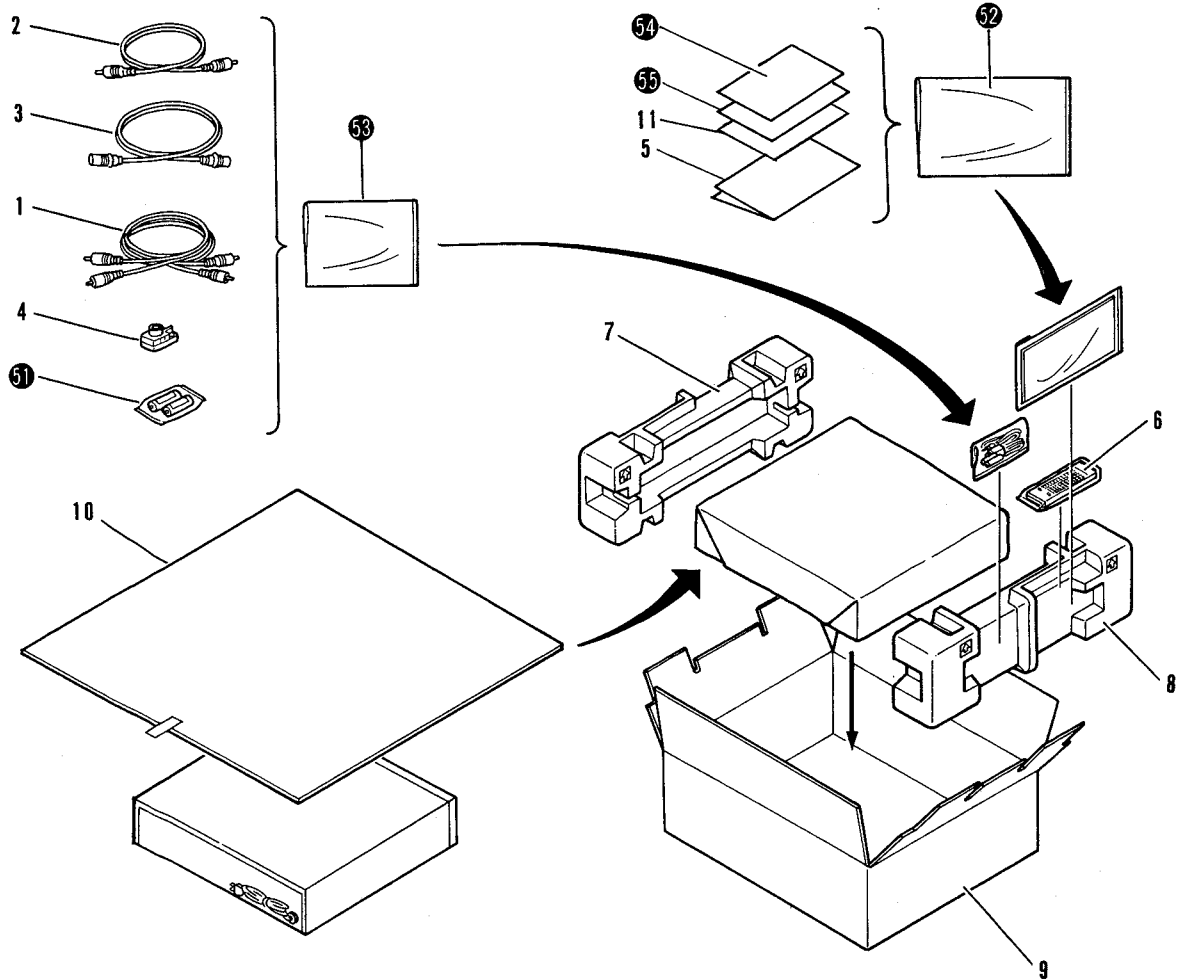

### ● Parts List of Packing

Mark	No.	Part No.	Description	Mark	No.	Part No.	Description
	1.	VDE1002 (VDE-055) (VDE-1005)	Audio cable	51.			Battery UM-4
	2.	VDE-056 (VDE1004)	Video cable	52.			Polyethylene bag
	3.	VDE1001 (VDE-054)	RF antenna cable	53.			Polyethylene bag
	4.	VKX-020	Antenna adaptor	54.			Caution card
	5.	VRB1003	Operating instructions	55.			Service net work
	6.	VXX1040	Remote control unit				
	7.	VHA1004	Pad (L)				
	8.	VHA1007	Pad (R)				
	9.	VHG1011	Packing case				
	10.	VHL-037	Sheet				
	11.	VRG1001	Sub operating instructions				

## 7. P.C. BOARDS LOCATION

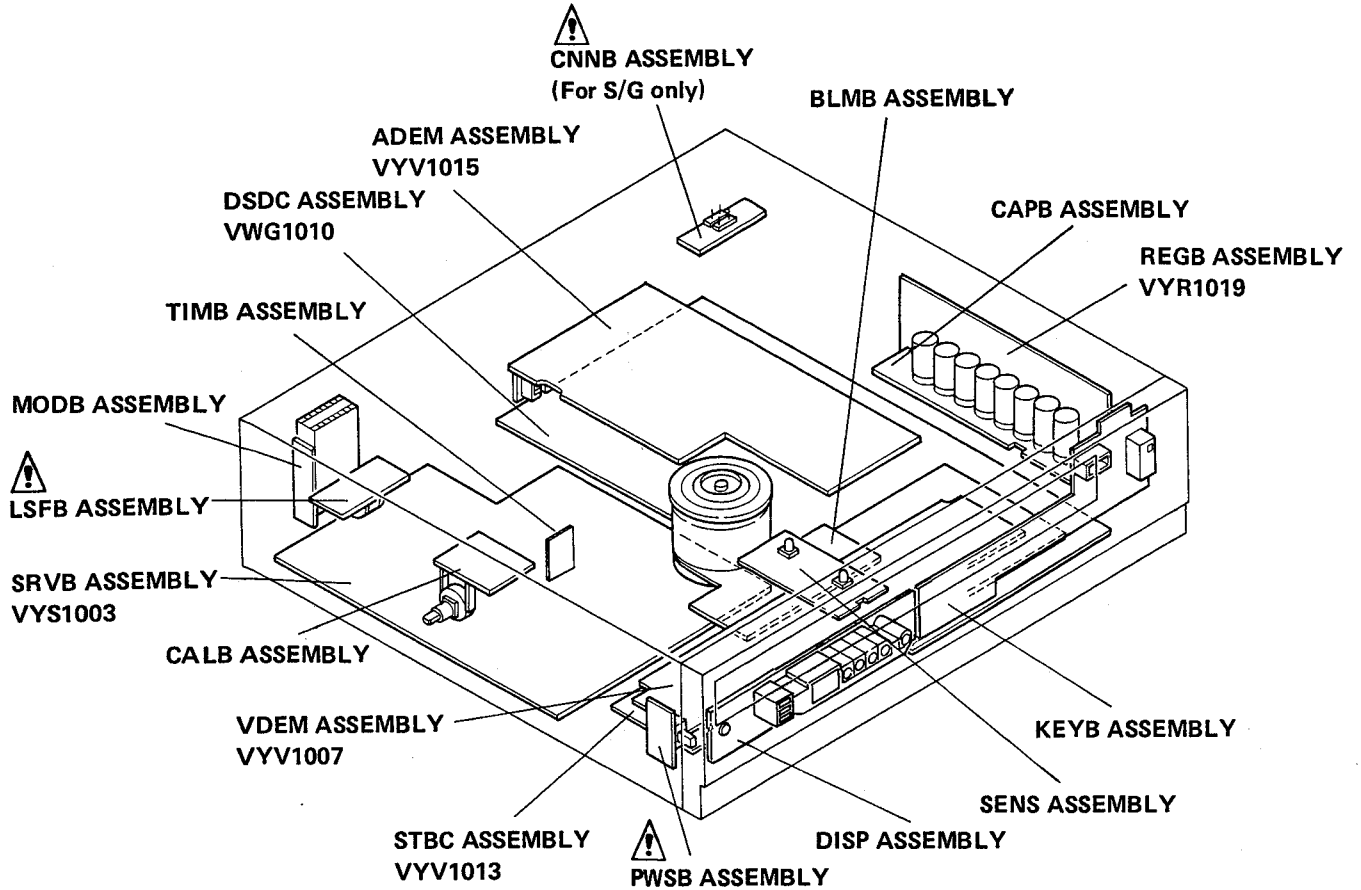

VWG1010	DSDC	(Digital Sound Demodulator Board)
VYS1003	SRVB	(Servo Board)
VYV1013	STBC	(Spindle & Time Base Corrector)
VYV1007	VDEM	(Video Demodulator)
VYV1015	ADEM	(Audio Demodulator)
	CAPB	(Capacitor Board)
	SENS	(Sensor Board)
VYR1019	REGB	(Regulator Board)
	LSFB	(Line Surge Filter Board)
	PWSB	(Power Switch Board)
	DISP	(Display Board)
	MODB	(Modulator Board)
	CALB	(Carry Loading Board)
	BLMB	(Blushless Motor Board)
	KEYB	(Key Board)
	TIMB	(Tilt Motor Board)
	CNNB	(Connection Board)

# 8. SCHEMATIC DIAGRAM AND P.C. BOARD PATTERNS

## 8.1 OVERALL CONNECTION DIAGRAMS

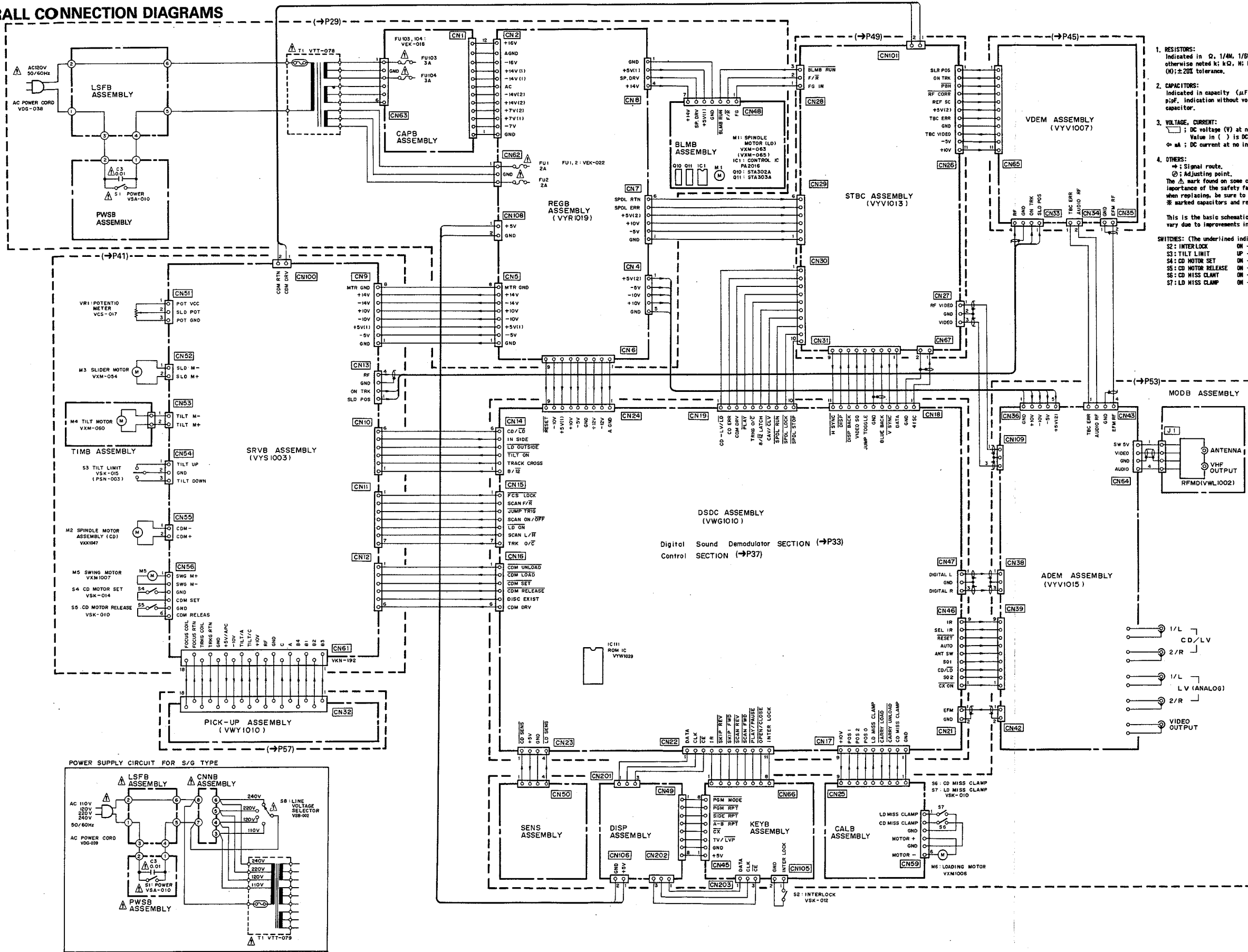

- RESISTORS:**  
Indicated in Ω, 1/4W, 1/8W and 1/2W. ±5% tolerance unless otherwise noted; K: Ω, M: MΩ, (F): ±1%, (D): ±2%, (K): ±10%, (N): ±20% tolerance.
  - CAPACITORS:**  
Indicated in capacity (μF)/voltage (V) unless otherwise noted. Value in ( ) is DC voltage at rated power. μF: Indication without voltage is 50V except electrolytic capacitor.
  - VOLTAGE, CURRENT:**  
□: DC voltage (V) at no input signal.  
Value in ( ) is DC voltage at rated power.  
⊙ mA: DC current at no input signal.
  - OTHERS:**  
→: Signal route.  
⊙: Adjusting point.  
The Δ mark found on some component parts indicates the importance of the safety factor of the part. Therefore, when replacing, be sure to use parts of identical designation, \* marked capacitors and resistors have parts numbers.
- This is the basic schematic diagram, but the actual circuit may vary due to improvements in design.
- SWITCHES:** (The underlined indicates the switch position)
- S2: INTER LOCK ON - OFF
  - S3: TILT LIMIT UP - DOWN
  - S4: CD MOTOR SET ON - OFF
  - S5: CD MOTOR RELEASE ON - OFF
  - S6: CD MISS CLAMP ON - OFF
  - S7: LD MISS CLAMP ON - OFF

A  
B  
C  
D

A  
B  
C  
D

8.2 REGB, LSFB, PWSB, CAPB, BLMB AND CNNB ASSEMBLY

1. RESISTORS:  
Indicated in Ω, 1/4W, 1/8W and 1/8W. ±5% tolerance unless otherwise noted; kΩ, MΩ, (F); ±1%, (G); ±2%, (K); ±10%, (N); ±20% tolerance.
  2. CAPACITORS:  
Indicated in capacity (μF)/voltage (V) unless otherwise noted; pF. Indication without voltage is 50V except electrolytic capacitor.
  3. VOLTAGE, CURRENT:  
□: DC voltage (V) at no input signal.  
□: DC voltage (V) at rated power.  
□: DC current at no input signal.
  4. OTHERS:  
→: Signal route.  
⊙: Adjusting point.  
The Δ mark found on some component parts indicates the importance of the safety factor of the part. Therefore, when replacing, be sure to use parts of identical designation.  
\* marked capacitors and resistors have parts numbers.
- This is the basic schematic diagram, but the actual circuit may vary due to improvements in design.
- SWITCHES: (The underlined indicates the switch position)  
PWSB ASSEMBLY  
S1: POWER ON - OFF

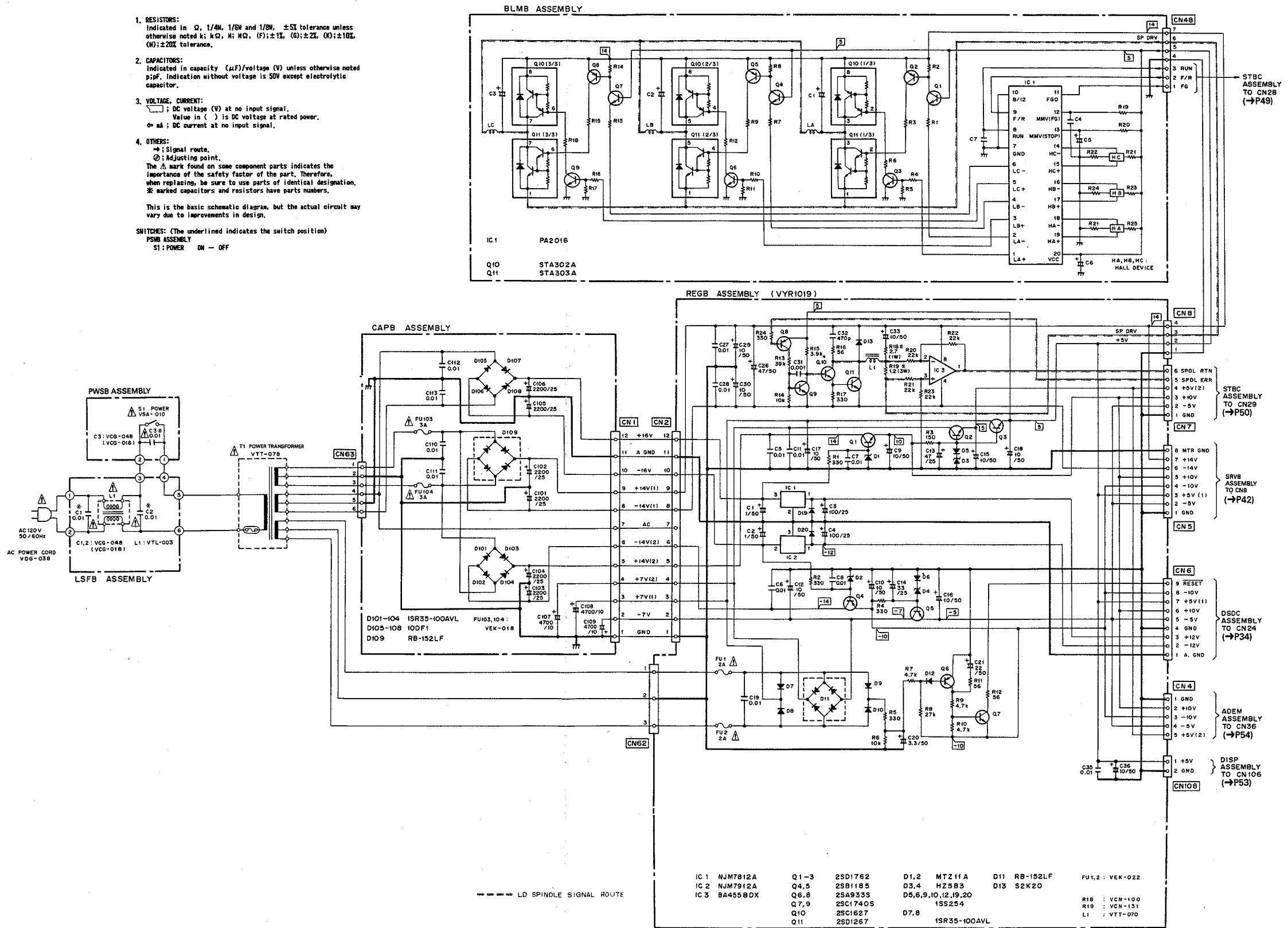



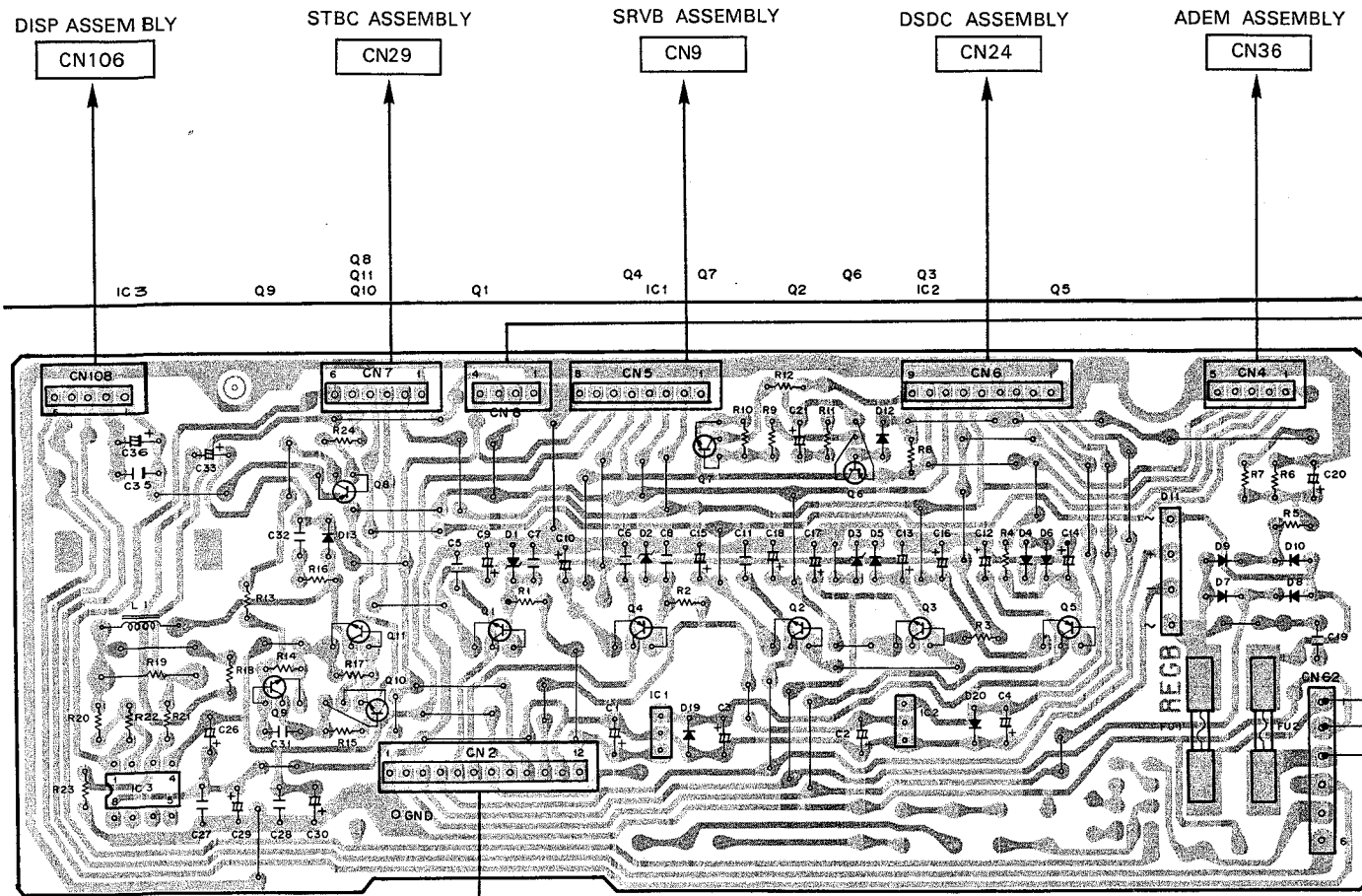

REGB ASSEMBLY(VYR1019)

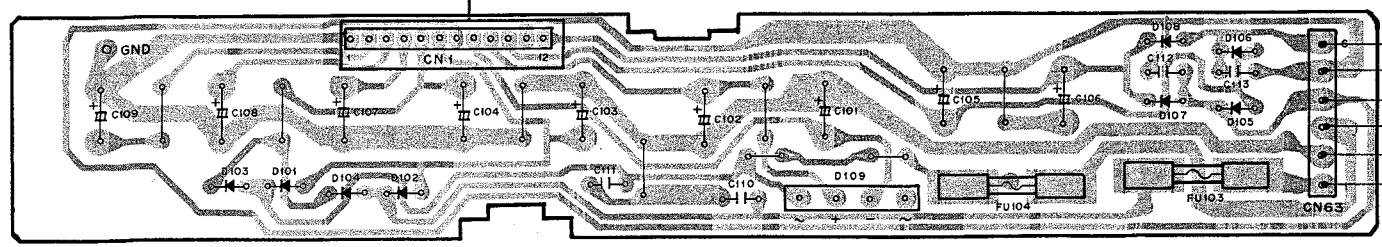

CAPB ASSEMBLY

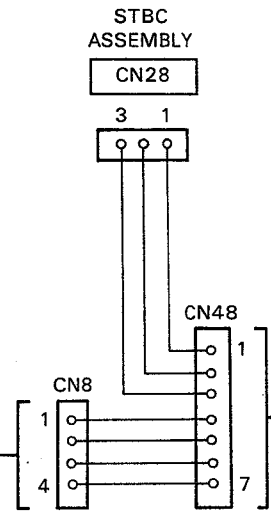

STBC ASSEMBLY CN28

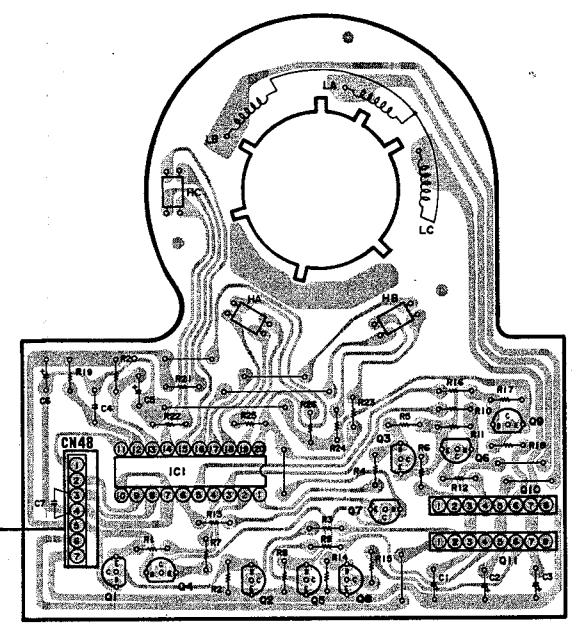

BLMB ASSEMBLY

PSWB ASSEMBLY

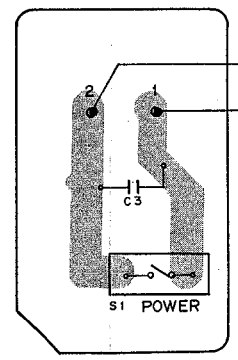

LSFB ASSEMBLY

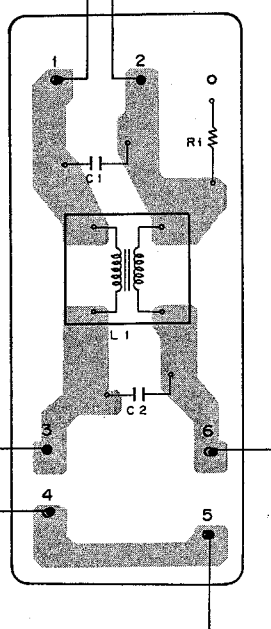

T1: VTT-078

A  
B  
C  
D

A  
B  
C  
D

1 2 3 4 5 6

8.3 DSDC ASSEMBLY (D.S.D SECTION)

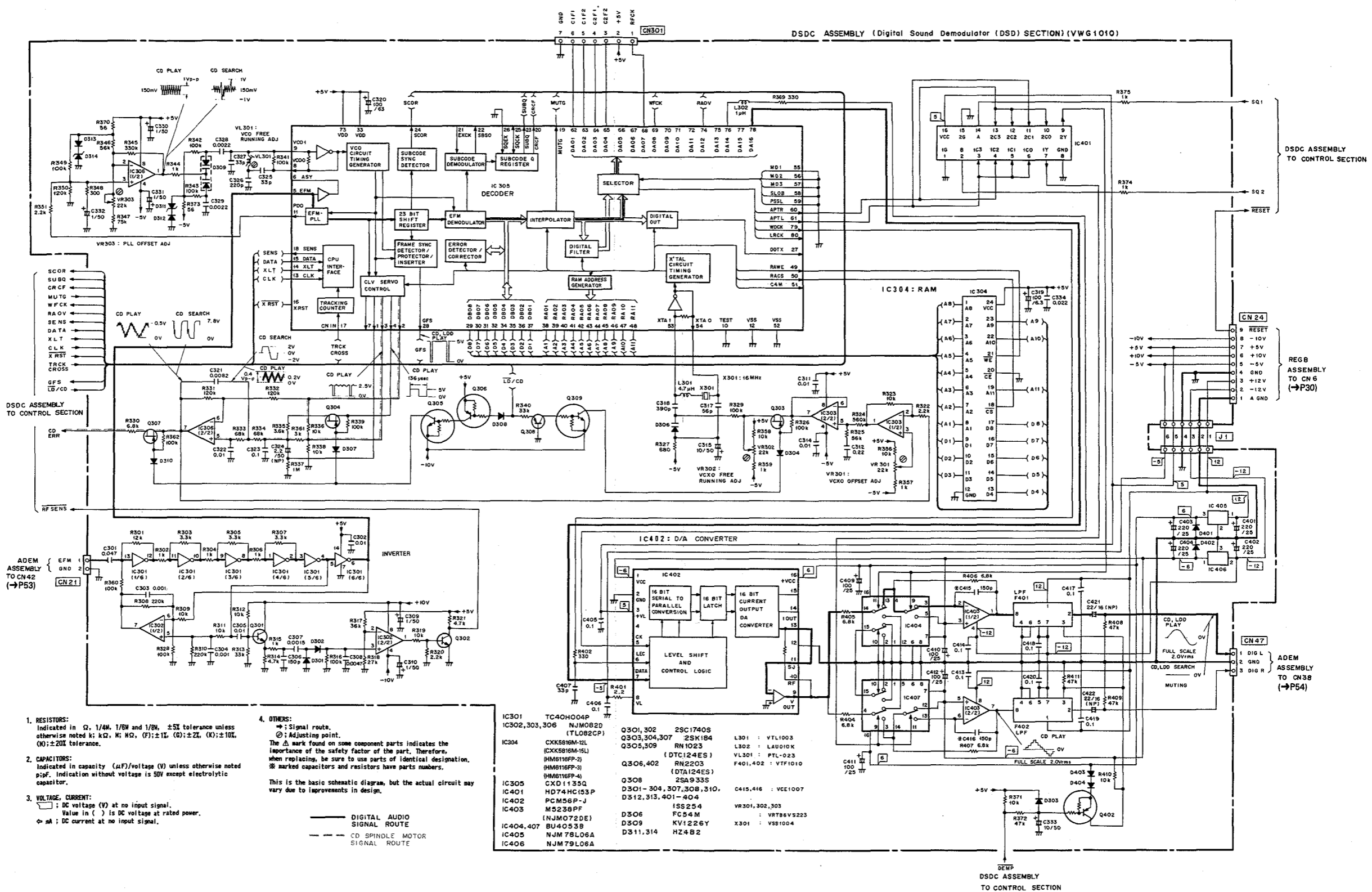

- RESISTORS:**  
Indicated in Ω, 1/4W, 1/8W and 1/16W, ±5% tolerance unless otherwise noted; K: 1K, M: 1M, (F): ±1%, (D): ±2%, (K): ±10%, (N): ±20% tolerance.
- CAPACITORS:**  
Indicated in capacity (μF)/voltage (V) unless otherwise noted pF. Indication without voltage is 50V except electrolytic capacitor.
- VOLTAGE, CURRENT:**  
□: DC voltage (V) at no input signal.  
Value in ( ) is DC voltage at rated power.  
⊙: DC current at no input signal.

- OTHERS:**  
→: Signal route.  
⊙: Adjusting point.  
The Δ mark found on some component parts indicates the importance of the safety factor of the part. Therefore, when replacing, be sure to use parts of identical designation. \* marked capacitors and resistors have parts numbers.  
This is the basic schematic diagram, but the actual circuit may vary due to improvements in design.

IC301	TC40H04P	Q301, 302	2SC1740S	L301	VTL1003
IC302, 303, 306	NJM082D (TL082CP)	Q303, 304, 307	2SK184	L302	LAU010X
IC304	CXK8816M-12L (CXK8816M-15L) (HM816FP-2) (HM816FP-4)	Q305, 308	RM1023 (DTC124ES) Q306, 402 RN2203 (DTA124ES)	VL301	PTL-023
IC305	CXD1135Q	Q308	2SA933S	F401, 402	VTF1010
IC401	HD74HC153P	D301-304, 307, 308, 310, D312, 313, 401-404	ISS254	C415, 416	VCE1007
IC402	PCM56P-J	D506	FC54M	VR301, 302, 303	V8786VS223
IC403	M5238PF (NJM072DE)	D509	KV1226Y	X301	V881004
IC404, 407	BU4053B	D311, 314	HZ4B2		
IC405	NJM79L06A				
IC406	NJM79L06A				

— DIGITAL AUDIO SIGNAL ROUTE  
- - - CD SPINDLE MOTOR SIGNAL ROUTE

1 2 3 4 5 6

ADEM ASSEMBLY ADEM ASSEMBLY CALB ASSEMBLY STBC ASSEMBLY SENS ASSEMBLY

CN42 CN38 CN25 CN31 CN67 CN50

**DSDC ASSEMBLY(VWG1010)**

IC407 IC403 IC404 IC405 Q402 Q304 Q308 Q309 Q303 Q305 Q306 Q307 Q112 IC305 IC304 Q109 IC105 Q103 Q102 Q101 Q108 IC103 Q107 IC111 IC101 IC104 IC102 IC109 IC108 IC107

Q301 IC301 IC302 VR301 VR302 VR303 Q104 Q105 Q106 Q107 Q108 Q109 Q110 Q111 Q112 Q113 Q114 Q115 Q116 Q117 Q118 Q119 Q120 Q121 Q122 Q123 Q124 Q125 Q126 Q127 Q128 Q129 Q130 Q131 Q132 Q133 Q134 Q135 Q136 Q137 Q138 Q139 Q140 Q141 Q142 Q143 Q144 Q145 Q146 Q147 Q148 Q149 Q150 Q151 Q152 Q153 Q154 Q155 Q156 Q157 Q158 Q159 Q160 Q161 Q162 Q163 Q164 Q165 Q166 Q167 Q168 Q169 Q170 Q171 Q172 Q173 Q174 Q175 Q176 Q177 Q178 Q179 Q180 Q181 Q182 Q183 Q184 Q185 Q186 Q187 Q188 Q189 Q190 Q191 Q192 Q193 Q194 Q195 Q196 Q197 Q198 Q199 Q200 Q201 Q202 Q203 Q204 Q205 Q206 Q207 Q208 Q209 Q210 Q211 Q212 Q213 Q214 Q215 Q216 Q217 Q218 Q219 Q220 Q221 Q222 Q223 Q224 Q225 Q226 Q227 Q228 Q229 Q230 Q231 Q232 Q233 Q234 Q235 Q236 Q237 Q238 Q239 Q240 Q241 Q242 Q243 Q244 Q245 Q246 Q247 Q248 Q249 Q250 Q251 Q252 Q253 Q254 Q255 Q256 Q257 Q258 Q259 Q260 Q261 Q262 Q263 Q264 Q265 Q266 Q267 Q268 Q269 Q270 Q271 Q272 Q273 Q274 Q275 Q276 Q277 Q278 Q279 Q280 Q281 Q282 Q283 Q284 Q285 Q286 Q287 Q288 Q289 Q290 Q291 Q292 Q293 Q294 Q295 Q296 Q297 Q298 Q299 Q300

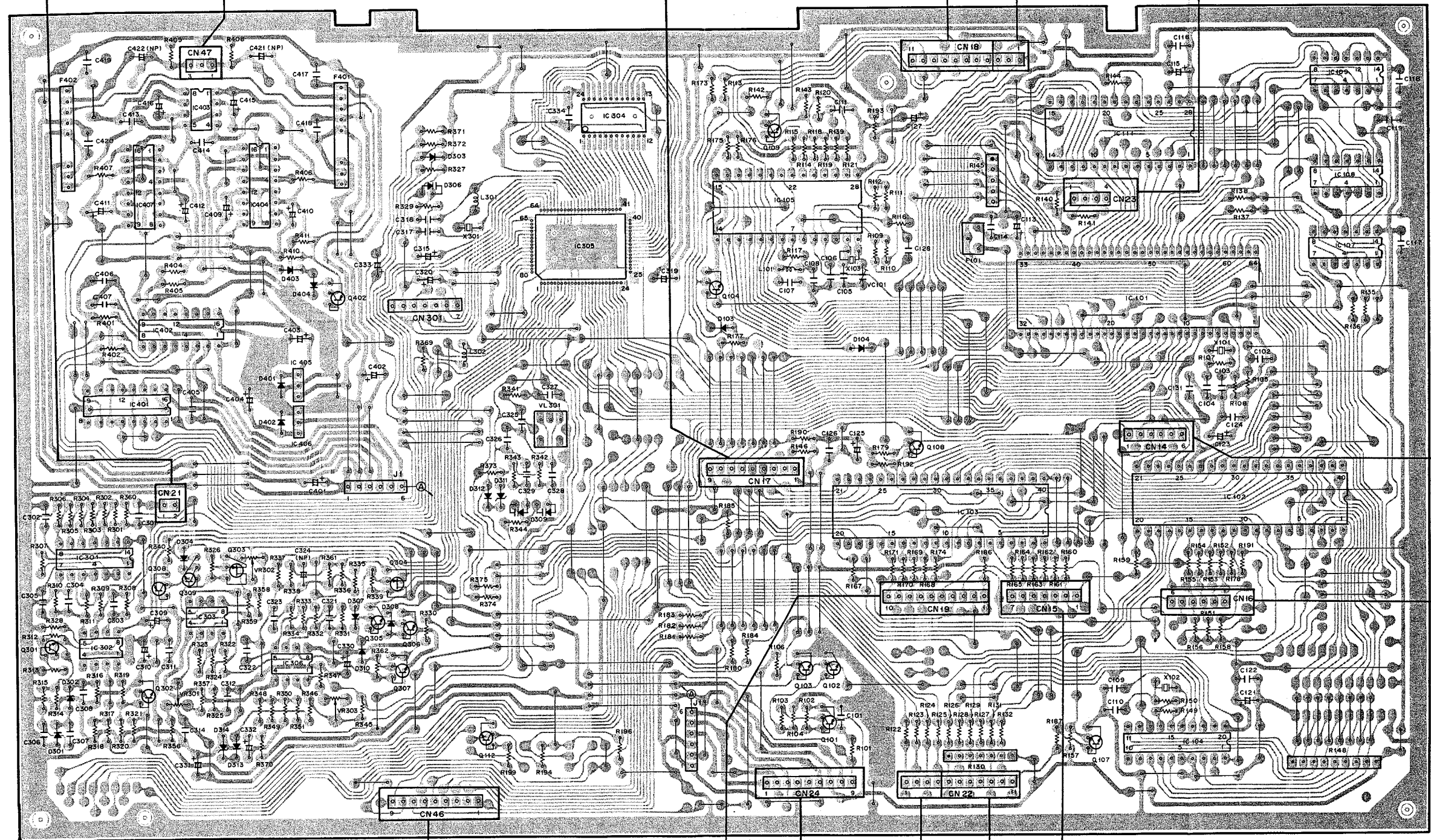

CN39 ADEM ASSEMBLY

CN30 STBC ASSEMBLY

CN6 REGB ASSEMBLY

CN201 DISP ASSEMBLY

CN66 KEYB ASSEMBLY

CN11 SRVB ASSEMBLY

SRVB ASSEMBLY CN10

SRVB ASSEMBLY CN12

8.4 DSDC ASSEMBLY (CONTROL SECTION)

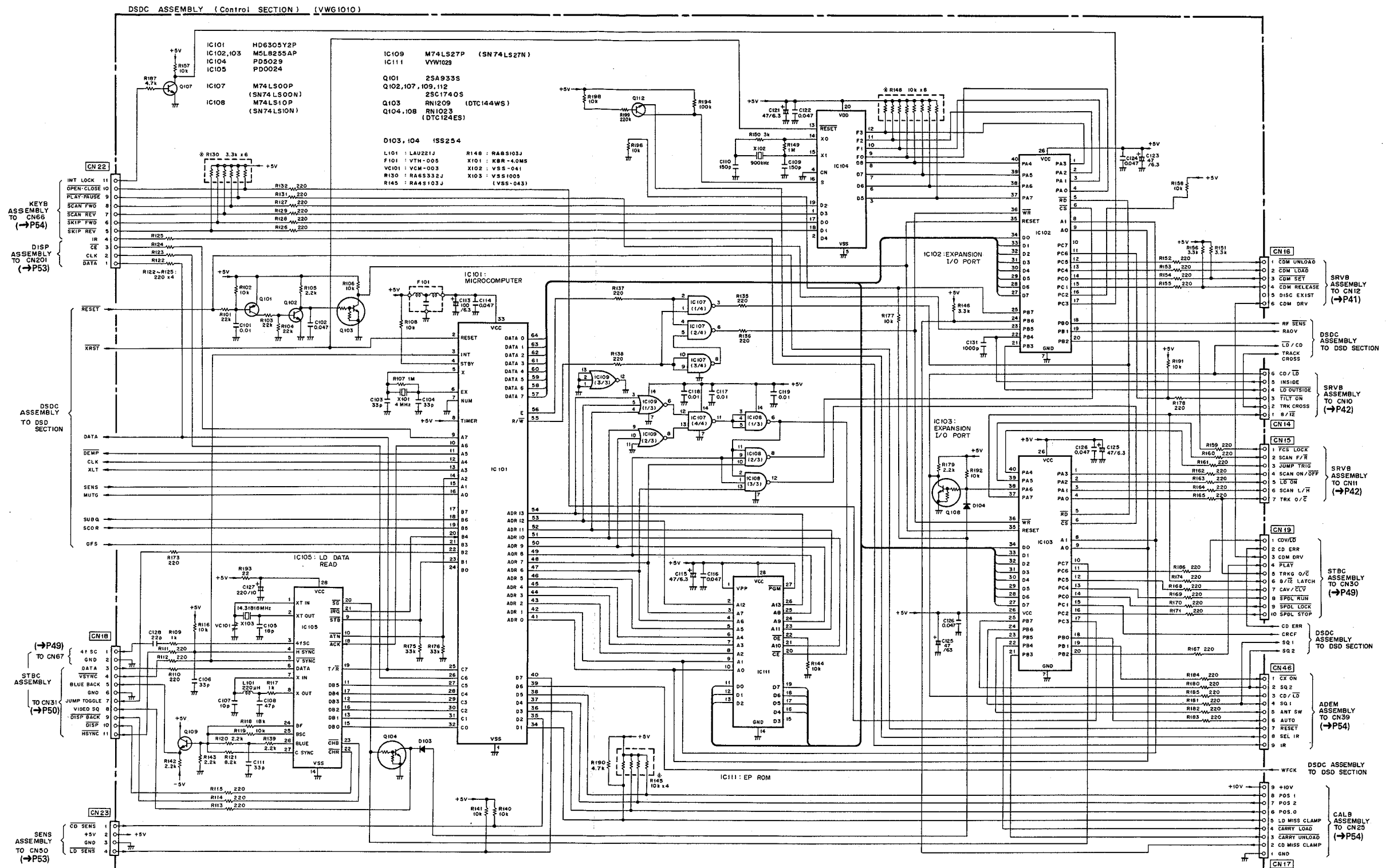



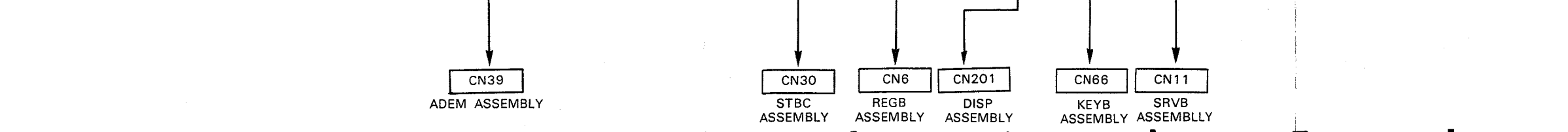
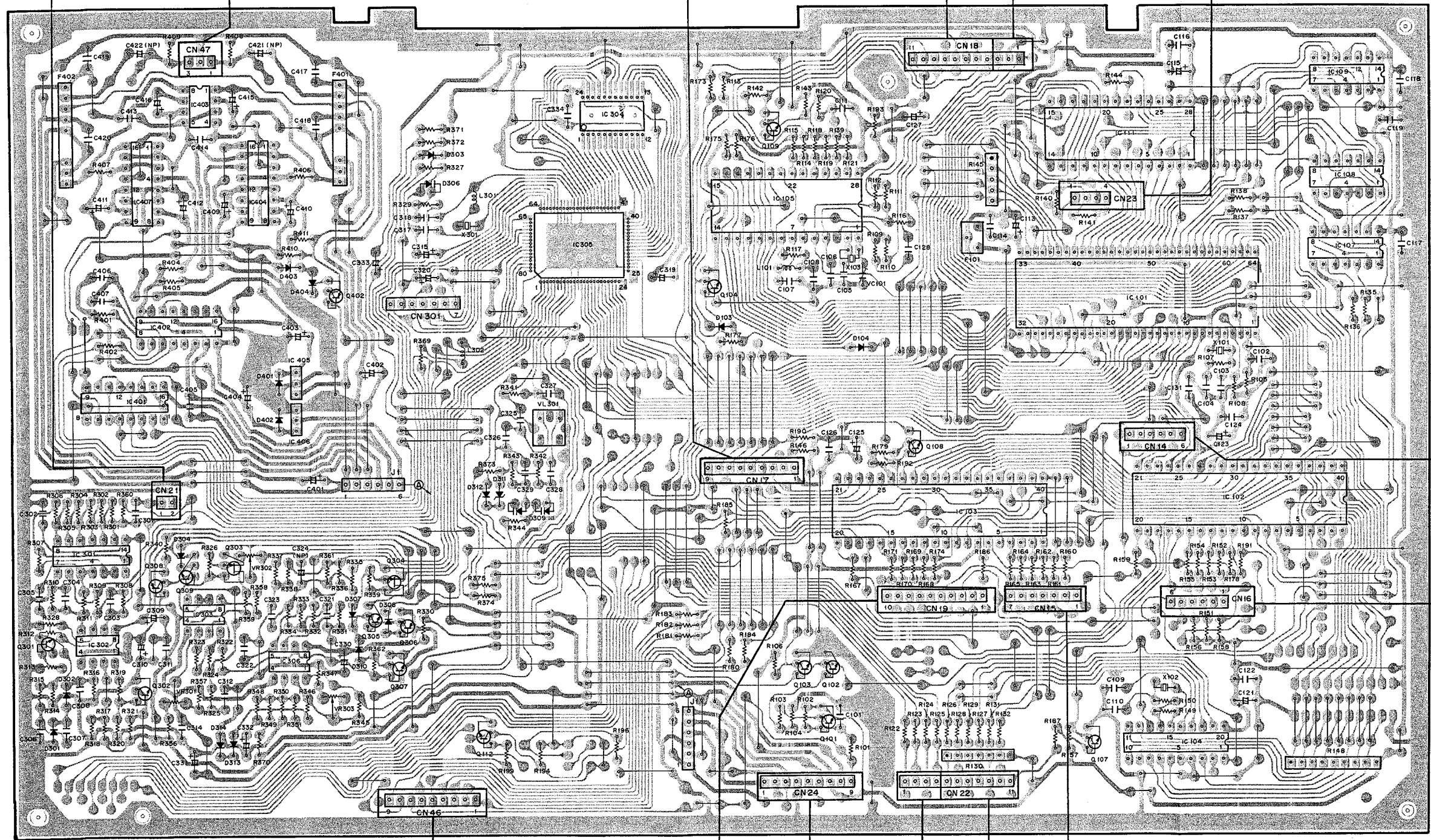
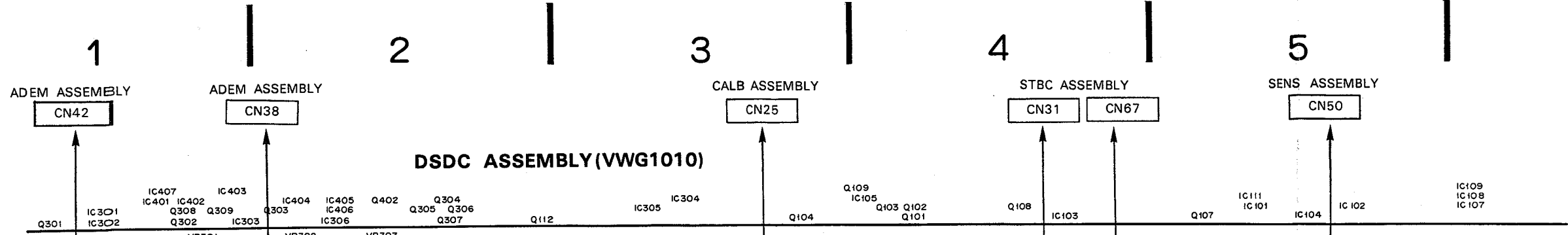

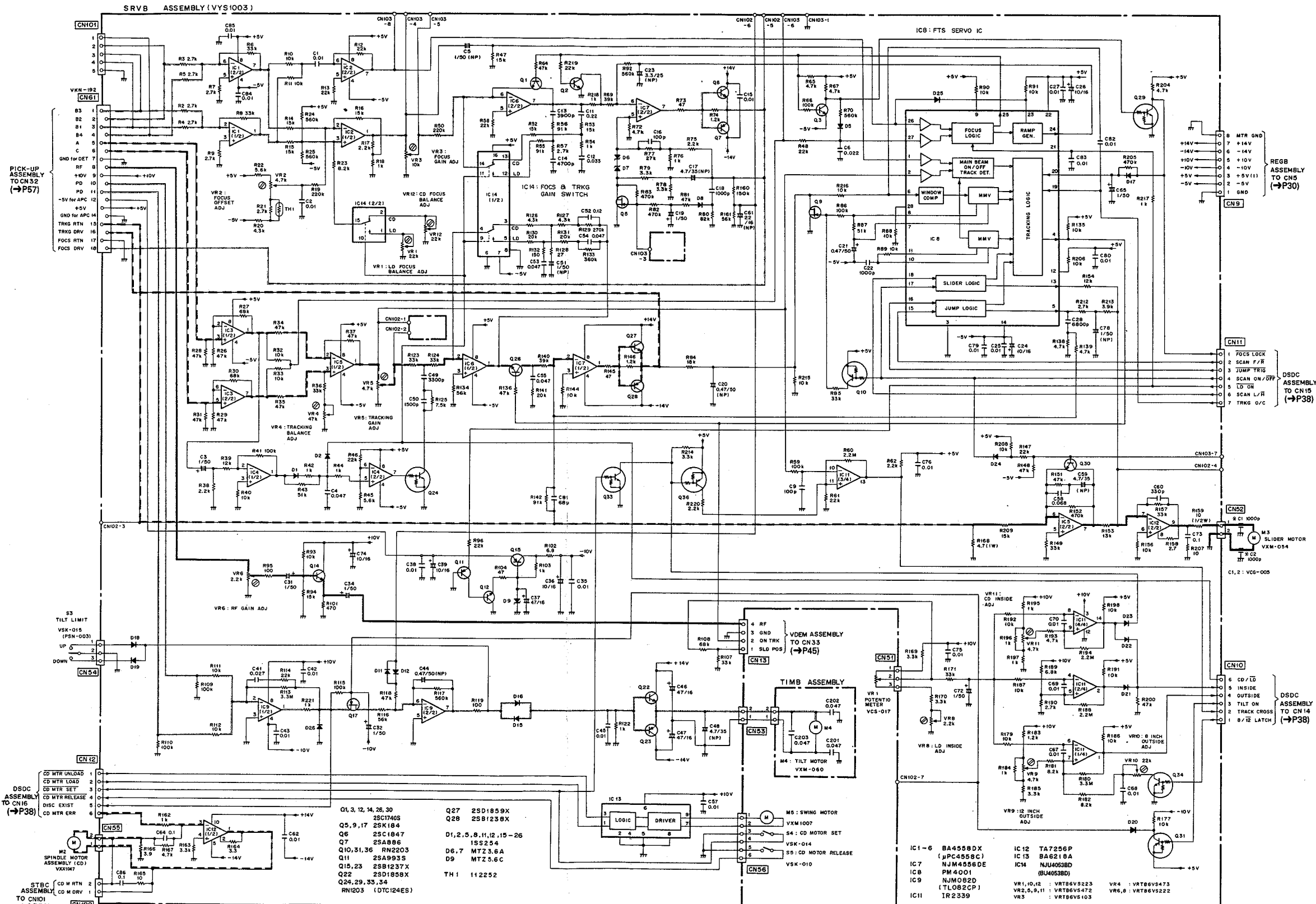

- 1. RESISTORS:**  
Indicated in Ω, 1/4W, 1/8W and 1/2W, ±5% tolerance unless otherwise noted; k: kΩ, M: MΩ, (F): ±1%, (D): ±2%, (K): ±10%, (N): ±20% tolerance.
- 2. CAPACITORS:**  
Indicated in capacity (μF)/voltage (V) unless otherwise noted; p: pF. Indication without voltage is 50V except electrolytic capacitor.
- 3. VOLTAGE, CURRENT:**  
Indicated in ( ) at no input signal.  
Value in ( ) is DC voltage at rated power.  
↖ mA: DC current at no input signal.
- 4. OTHERS:**  
→: Signal route.  
⊙: Adjusting point.
- 5. SWITCHES:** (The underlined indicates the switch position)  
S3: TILT LIMIT  
S4: CD MOTOR SET ON - OFF  
S5: CD MOTOR RELEASE ON - OFF
- 6. SIGNAL ROUTES:**  
--- RF SIGNAL ROUTE  
--- CD SPINDLE SIGNAL ROUTE  
--- TILT SERVO SIGNAL ROUTE  
--- FOCUS SERVO SIGNAL ROUTE  
--- SLIDER SIGNAL ROUTE  
--- TRACKING SERVO SIGNAL ROUTE

1

2

3

4

5

6

A

A

B

B

C

C

D

D

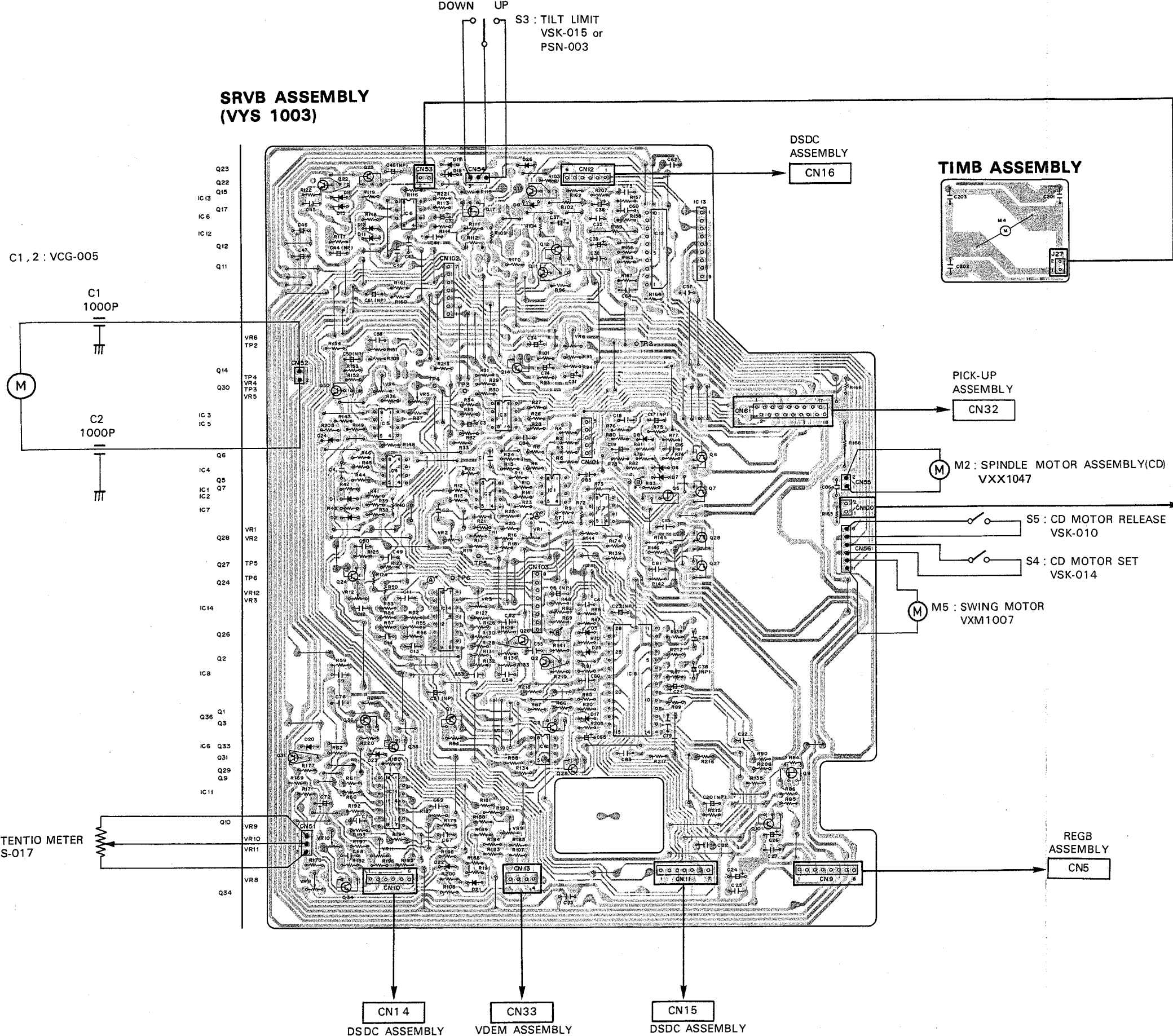

1

2

3

4

5

6

VDEM ASSEMBLY (VYV1007)

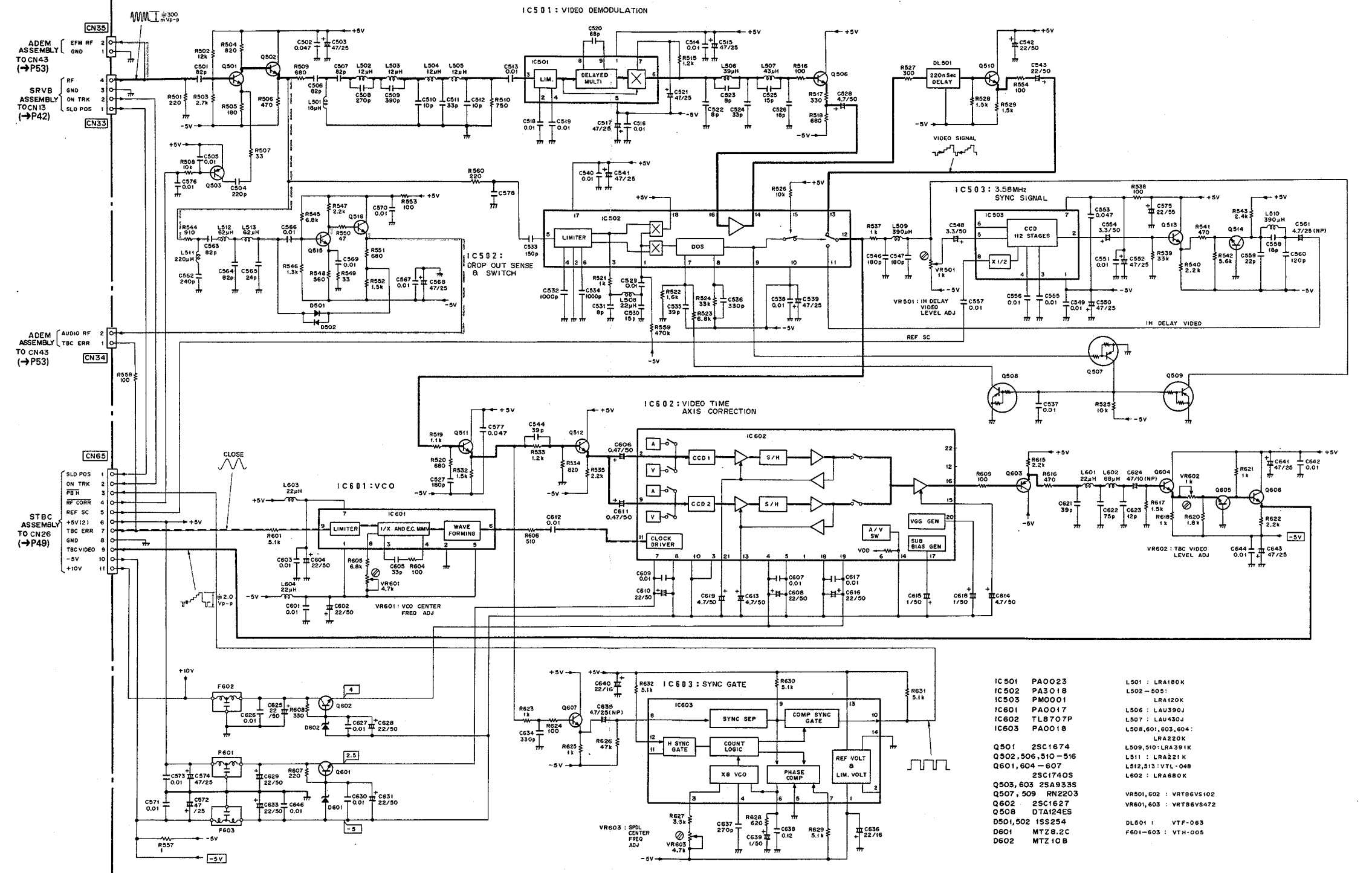

1. RESISTORS:  
Indicated in Ω, 1/4W, 1/8W and 1/16W, ±5% tolerance unless otherwise noted; K: KΩ, M: MΩ, (F): ±1%, (G): ±2%, (J): ±10%, (W): ±20% tolerance.
2. CAPACITORS:  
Indicated in capacity (μF)/voltage (V) unless otherwise noted; p: pF. Indication without voltage is 50V except electrolytic capacitor.
3. VOLTAGE, CURRENT:  
□: DC voltage (V) at no input signal.  
Value in ( ) is DC voltage at rated power.  
← mA: DC current at no input signal.
4. OTHERS:  
→: Signal route.  
⊗: Adjusting point.  
The Δ mark found on some component parts indicates the importance of the safety factor of the part. Therefore, when replacing, be sure to use parts of identical designation. \* marked capacitors and resistors have parts numbers.
- This is the basic schematic diagram, but the actual circuit may vary due to improvements in design.

IC501	PA0023	L501	LRA180K
IC502	PA5018	L502-505	LRA120K
IC503	PM0001	L506	LAU390J
IC601	PA0017	L507	LAU300J
IC602	TL8707P	L508,601,603,604	LRA220K
IC603	PA0018	L509,510	LRA391K
Q501	2SC1674	L511	LRA221K
Q502,506,510-516	2SC1627	L512,513	VTL-048
Q601,604-607	2SC1740S	L602	LRA680X
Q503,603	2SA933S		
Q507,509	RN2203		
Q602	2SC1627	VR501,502	VRT6V5102
Q508	DTA124ES	VR601,603	VRT6V5472
D501,502	1SS254		
D601	MT28.2C		
D602	MT210B		





1 2 3 4 5 6

A

A

ADEM ASSEMBLY

CN43

VDEM VDEM ASSEMBLY (VYV1007)

IC603 Q607 Q501 Q502 Q516 Q515 IC501 VR501 IC503 Q506 Q509 Q508 Q507 Q513 IC502 Q514 Q511 Q510 Q512 Q605 Q606 Q603 Q604 Q602 Q601 IC602 IC601

VR603 VR602 VR601

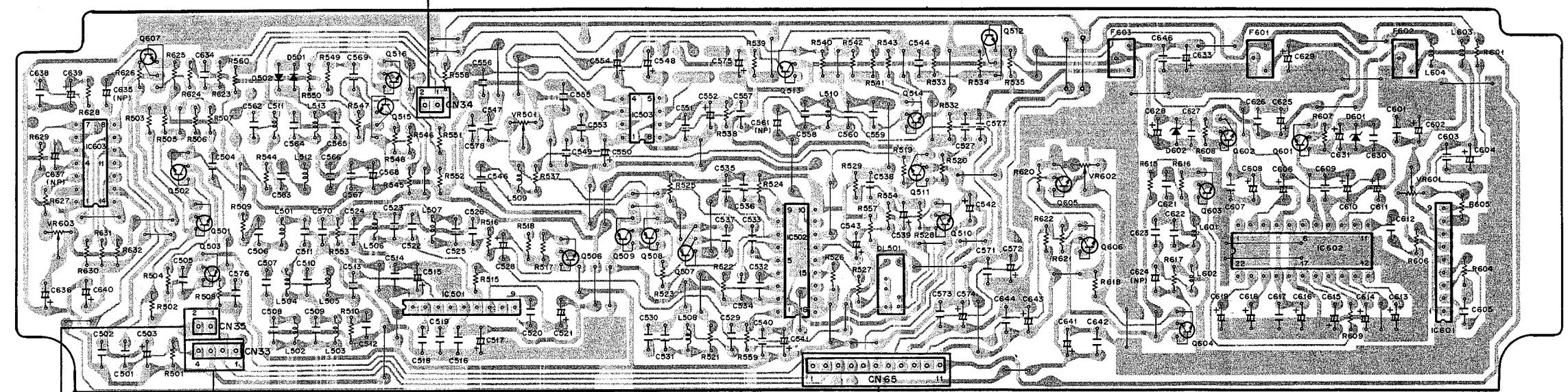

B

B

C

C

CN43 ADEM ASSEMBLY

CN13 SRVB ASSEMBLY

CN26 STBC ASSEMBLY

D

D

1 2 3 4 5 6

STBC ASSEMBLY (VYV1013)

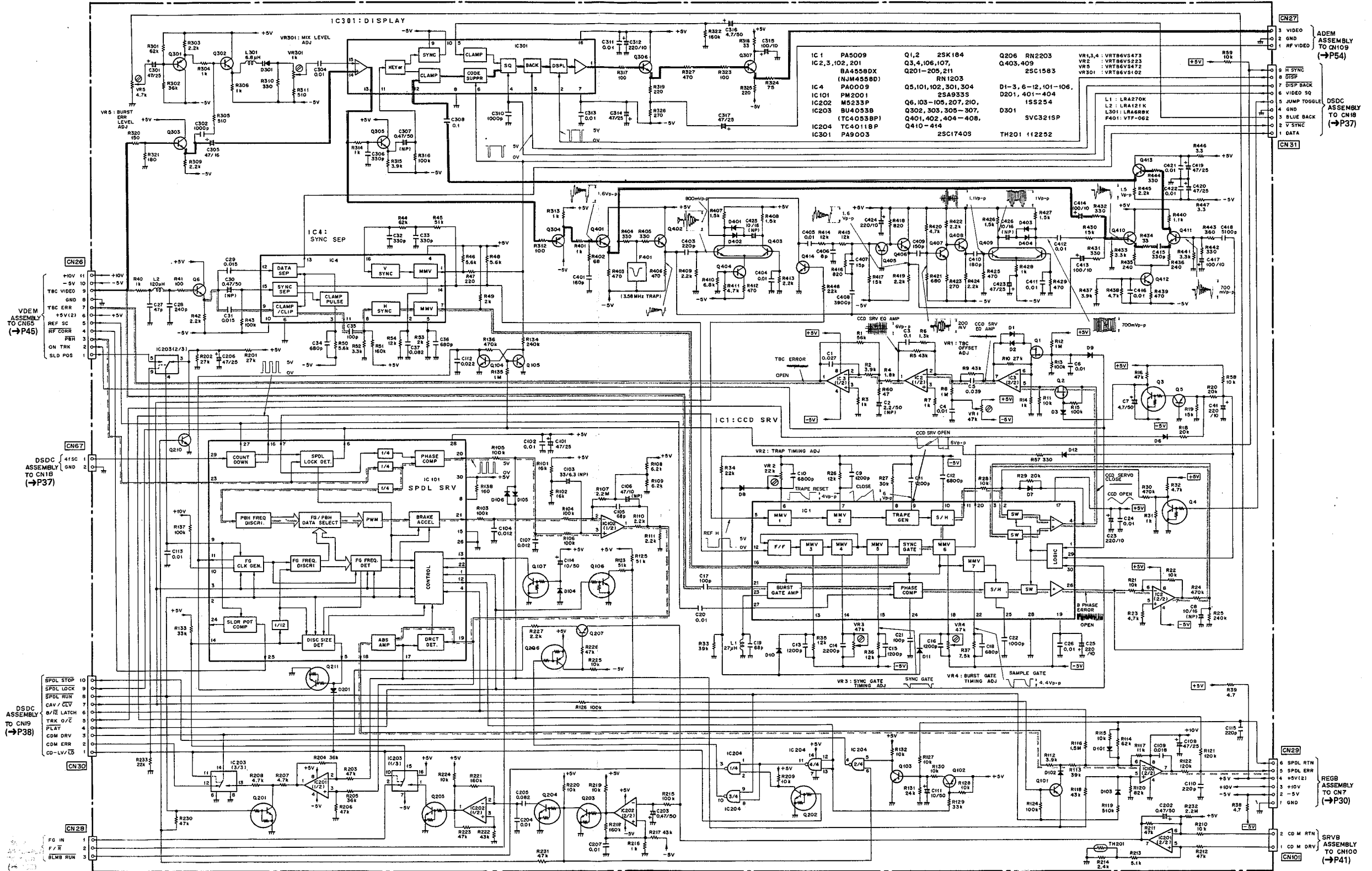

1. RESISTORS: Indicated in Ω, 1/4W, 1/8W and 1/2W. ±5% tolerance unless otherwise noted; k: kΩ, M: MΩ, (F): ±1%, (D): ±2%, (K): ±10%, (O): ±20% tolerance.

2. CAPACITORS: Indicated in capacity (μF)/voltage (V) unless otherwise noted; p: pF. Indication without voltage is 50V except electrolytic capacitor.

3. VOLTAGE, CURRENT: □: DC voltage (V) at no input signal. Value in ( ) is DC voltage at rated power. ◊: DC current at no input signal.

4. OTHERS: ⊕: Signal route. ⊙: Adjusting point. The Δ mark found on some component parts indicates the importance of the safety factor of the part. Therefore, when replacing, be sure to use parts of identical designation. \* marked capacitors and resistors have parts numbers. This is the basic schematic diagram, but the actual circuit may vary due to improvements in design.

VIDEO SIGNAL ROUTE  
 CCD SERVO SIGNAL ROUTE  
 SPDL LOCK DETECT ROUTE

1 | 2 | 3 | 4 | 5 | 6

A

B

C

D

A

B

C

D

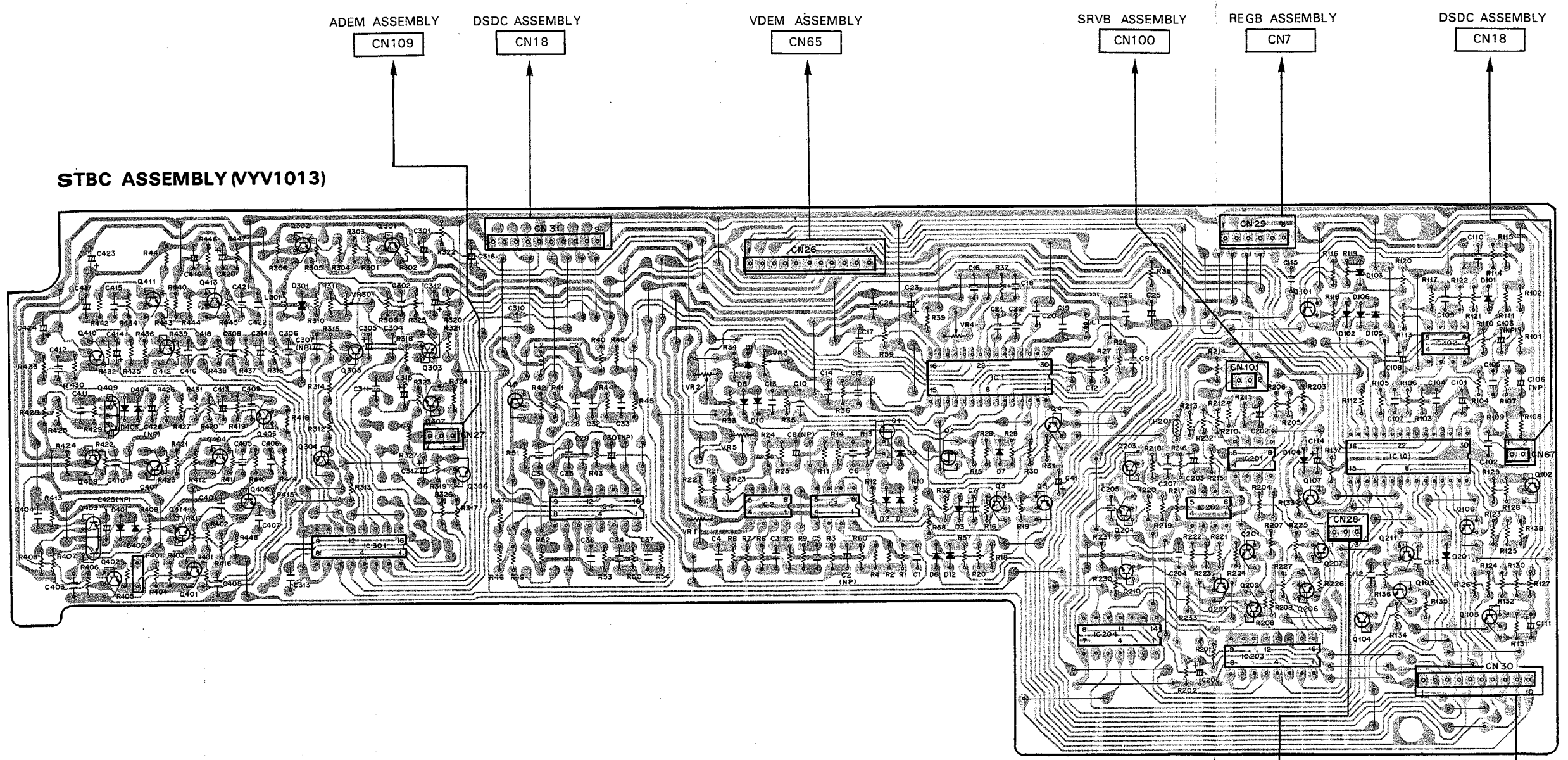

STBC ASSEMBLY (YV1013)

Q410	Q411	Q413	Q302	Q301	Q303	Q6	IC4	VR2	VR1	VR5	VR3	VR4	Q4	Q203	IC202	IC201	Q101	IC101	IC102	Q102						
Q408	Q409	Q412	Q404	Q406	Q304	Q305	Q307	VR1	VR5	VR3	IC2	IC3	Q1	Q2	IC1	Q3	Q5	Q4	Q204	IC205	IC201	Q107	IC101	IC102	Q106	Q102
Q403	Q402	Q407	Q405	Q405	Q304	Q305	Q306	VR1	VR5	VR3	IC2	IC3	Q1	Q2	IC1	Q3	Q5	Q4	Q204	IC205	IC201	Q107	IC101	IC102	Q106	Q102
	Q402	Q414	Q401				IC301																			

1 | 2 | 3 | 4 | 5 | 6

8.8 ADEM, CALB, DISP, KEYB, SENS AND MODB ASSEMBLY

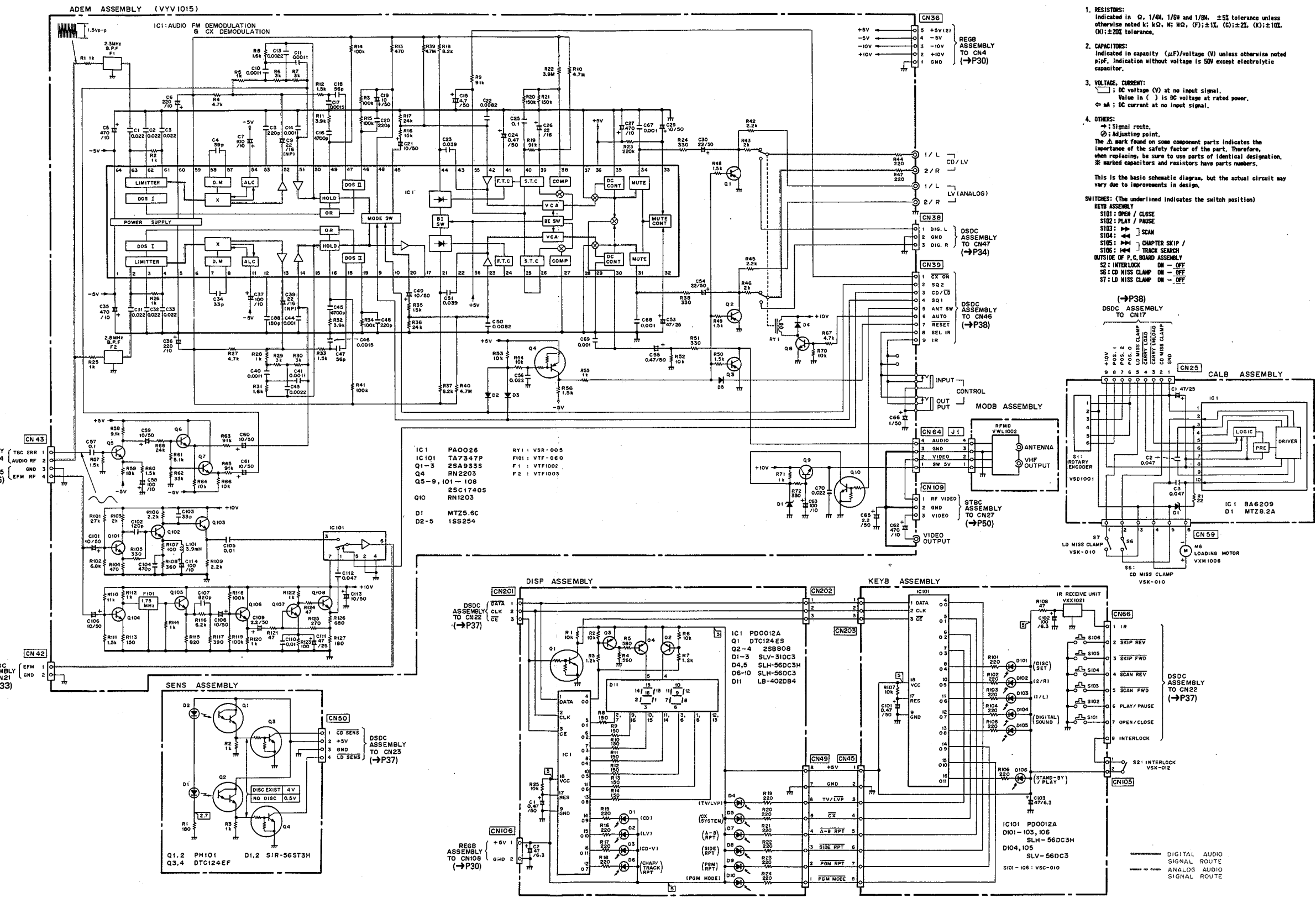

IC 1 PA0026  
 IC 101 TA7347P  
 Q1-3 25A9335  
 Q4 RN2203  
 Q5-9, I01-108 25C17405  
 Q10 RN1203  
 D1 MTZ5.6C  
 D2-5 ISS254

RY1 V5A-009  
 FID1 V7F-060  
 F1 V7F1002  
 F2 V7F1005

- RESISTORS:** Indicated in Ω, 1/4W, 1/8W and 1/16W. ±5% tolerance unless otherwise noted; kΩ, MΩ, GΩ, (F)±1%, (G)±2%, (O)±10%, (N)±20% tolerance.
  - CAPACITORS:** Indicated in capacity (μF)/voltage (V) unless otherwise noted; pF. Indication without voltage is 50V except electrolytic capacitor.
  - VOLTAGE, CURRENT:** □: DC voltage (V) at no input signal, Value in ( ) is DC voltage at rated power. ◊: AC current at no input signal.
  - OTHERS:** ⊕: Signal route, ⊙: Adjusting point. The Δ mark found on some component parts indicates the importance of the safety factor of the part. Therefore, when replacing, be sure to use parts of identical designation. \* marked capacitors and resistors have parts numbers.
- This is the basic schematic diagram, but the actual circuit may vary due to improvements in design.
- SWITCHES:** (The underlined indicates the switch position)
- KEYB ASSEMBLY**
- S101: OPEN / CLOSE
  - S102: PLAY / PAUSE
  - S103: SCAN
  - S104: CHAPTER SKIP / TRACK SEARCH
  - S105: REVERSE
  - S106: F.W. / REVERSE
- OUTSIDE OF P.C. BOARD ASSEMBLY**
- S2: INTERLOCK ON - OFF
  - S3: CD MISS CLAMP ON - OFF
  - S4: LD MISS CLAMP ON - OFF
  - S5: CD MISS CLAMP ON - OFF
  - S6: LD MISS CLAMP ON - OFF



1 | 2 | 3 | 4 | 5 | 6

A

B

C

D

A

B

C

D

### MODB ASSEMBLY

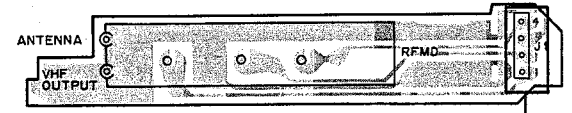

### STBC ASSEMBLY

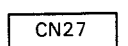

### ADEM ASSEMBLY (VYV1015)

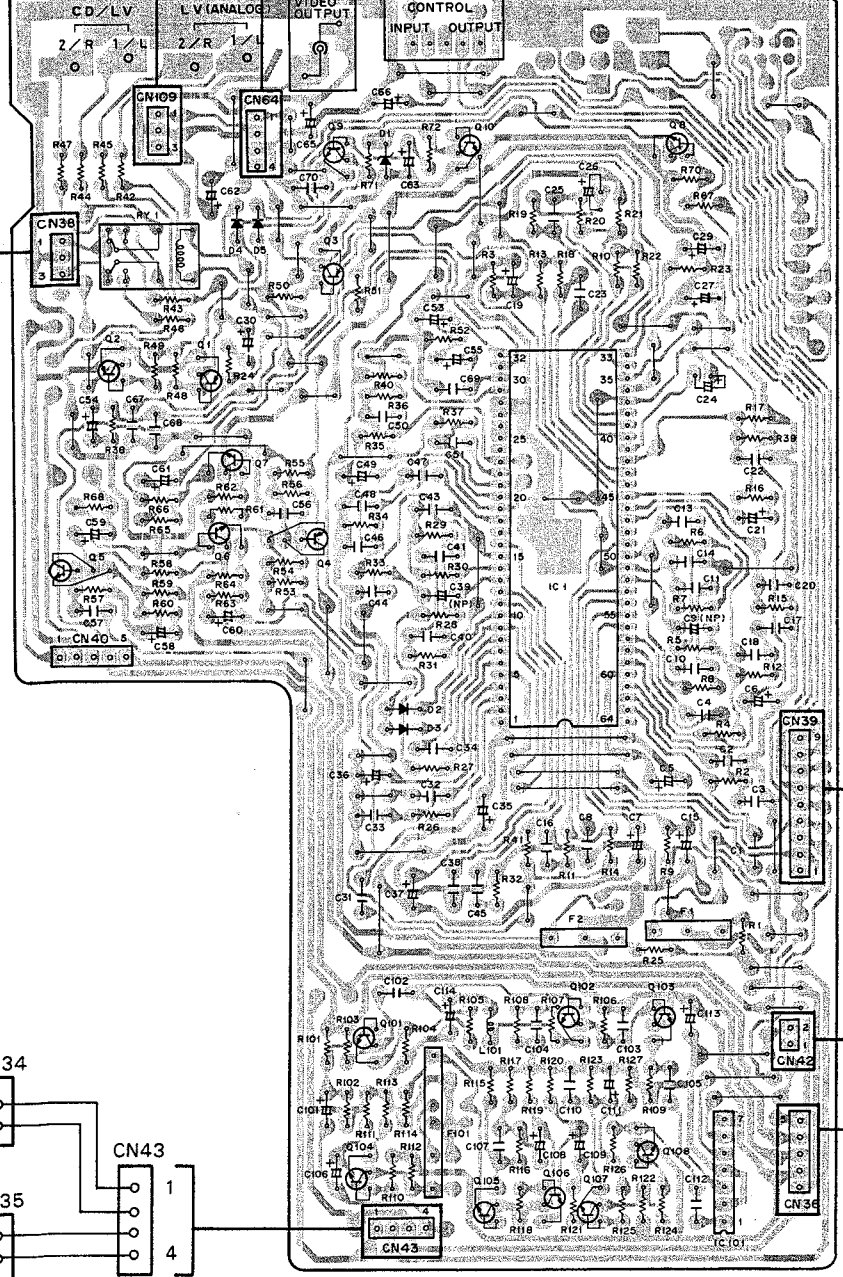

Q8  
Q9  
Q10  
Q3  
Q2  
Q1  
Q7  
Q6  
Q5  
Q4  
IC1  
Q102  
Q103  
Q101  
Q108  
Q104  
Q106  
Q105  
Q107  
IC101

### CALB ASSEMBLY

S6 : CD MISS CLAMP  
S7 : LD MISS CLAMP

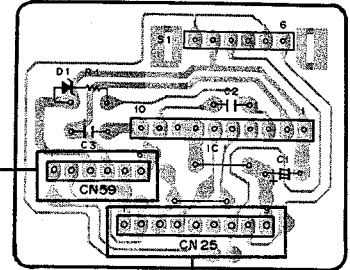
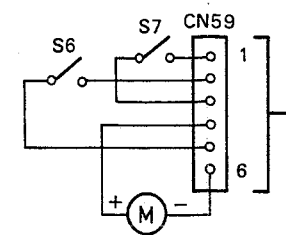

### DSDC ASSEMBLY

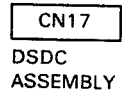

S2 : INTERLOCK

### KEYB ASSEMBLY

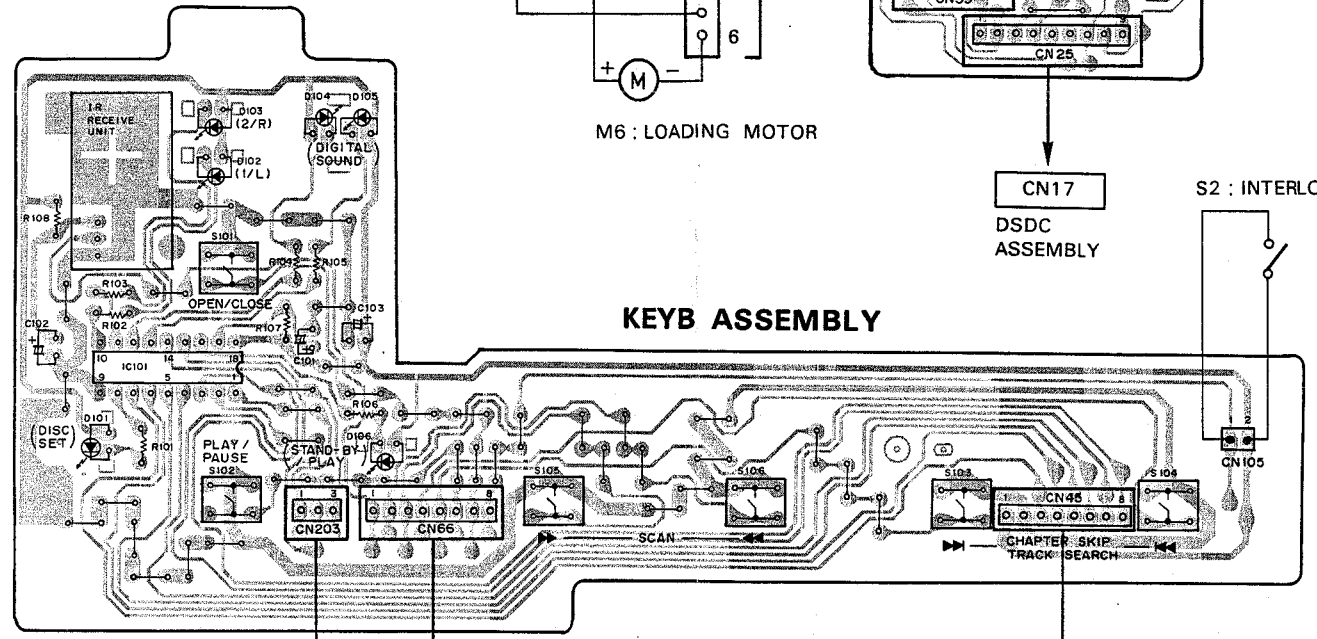

### DSDC ASSEMBLY



### DISP ASSEMBLY

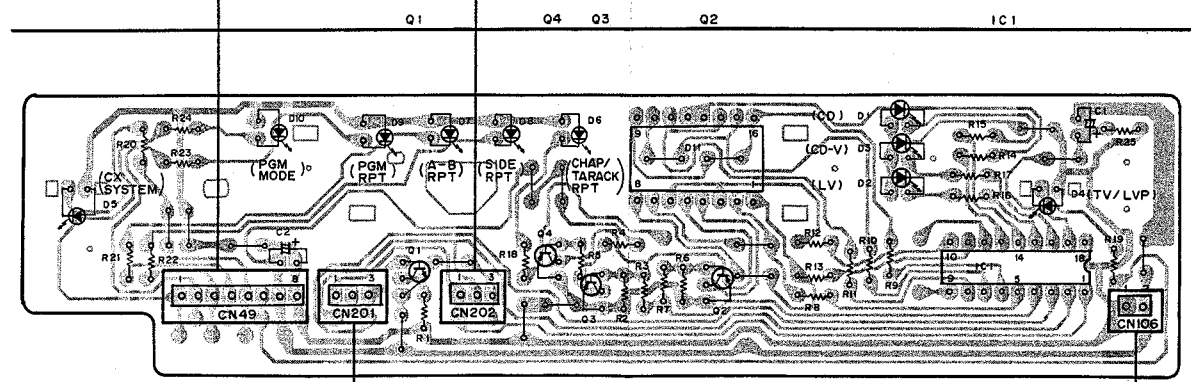

### DSDC ASSEMBLY

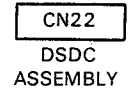

### REGB ASSEMBLY

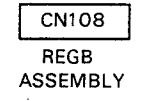

1 | 2 | 3 | 4 | 5 | 6

A

PICK-UP ASSEMBLY (VWY1010)

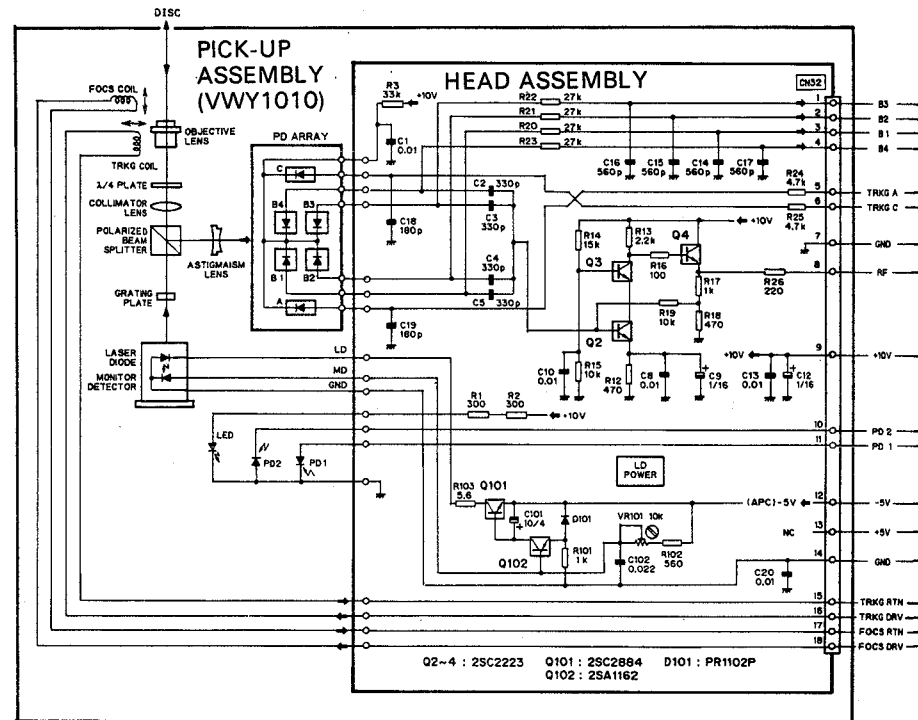

HEAD ASSEMBLY

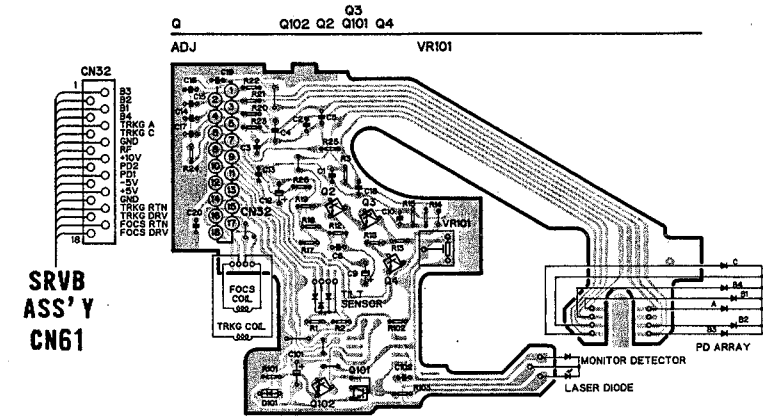

SRVB ASSEMBLY TO CN61 (P41)

1. RESISTORS:  
Indicated in Ω, 1/4W, 1/6W and 1/8W, ±5% tolerance unless otherwise noted k; kΩ, M; MΩ, (F); ±1%, (G); ±2%, (K); ±10%, (N); ±20% tolerance.
  2. CAPACITORS:  
Indicated in capacity (μF)/voltage (V) unless otherwise noted p;pF. Indication without voltage is 50V except electrolytic capacitor.
  3. VOLTAGE, CURRENT:  
□; DC voltage (V) at no input signal.  
Value in ( ) is DC voltage at rated power.  
← mA; DC current at no input signal.
  4. OTHERS:  
→; Signal route.  
⊙; Adjusting point.  
The Δ mark found on some component parts indicates the importance of the safety factor of the part. Therefore, when replacing, be sure to use parts of identical designation.  
\* marked capacitors and resistors have parts numbers.
- This is the basic schematic diagram, but the actual circuit may vary due to improvements in design.

B

C

D

A

B

C

D

External Appearance of Transistors and ICs

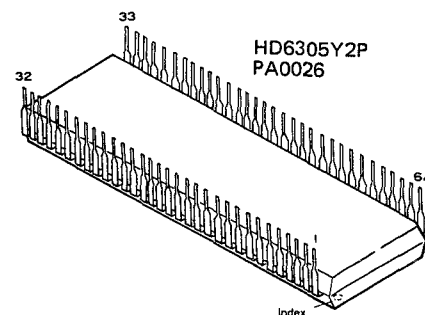
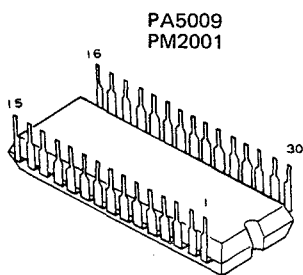
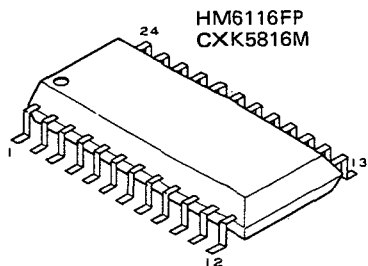

2SA886

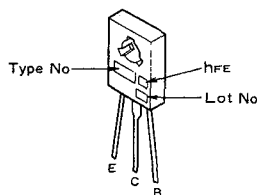

PD5029

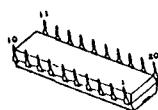

PA0023  
PA0017

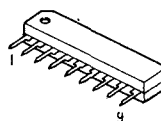

TL8707P

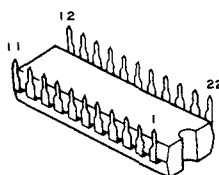

BA4558DX

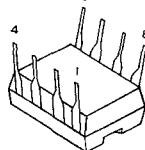

NJM072DE  
NJM4558D  
PM0001  
NJM4556DE  
NJM082D

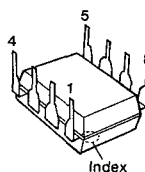

PA2016

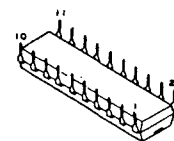

PH101



STA302A  
STA303A

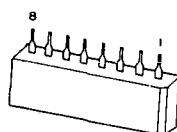

TA7347P

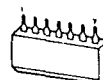

M5L8255AP

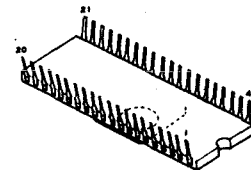

2SD1267

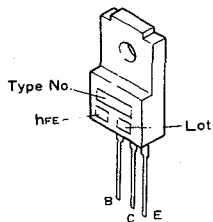

DTC144WS

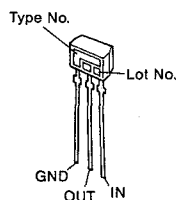

2SC1583

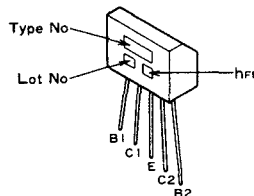

NJM79L06A

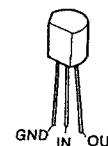

2SB808  
DTA124ES  
DTC124ES  
DTC124EF

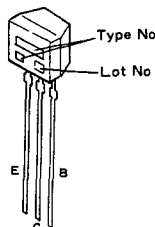

2SC1674



BU4053BD  
BU4053B  
NJU4053BD  
NJU4053B

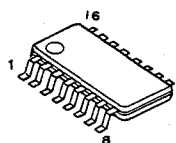

2SA933S  
2SC1740S

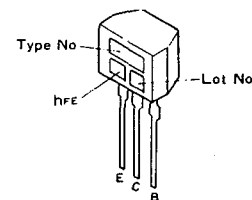

**CLD-1010**

2SK184



RN2203  
RN1203  
RN1209

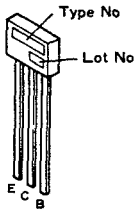

NJM7912A

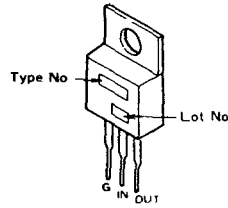

2SC1627

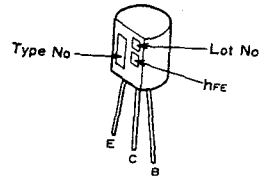

PA3018  
PD0012A

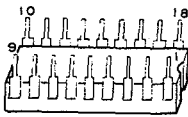

BA6218A

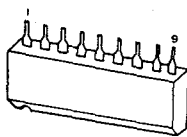

TA7256P

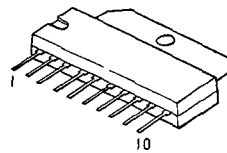

BA6209

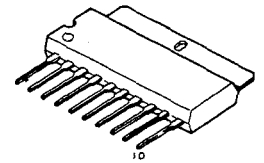

NJM7812A

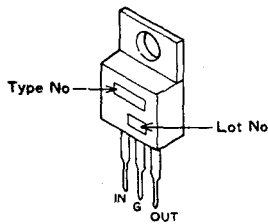

2SC1847



NJM78L06A

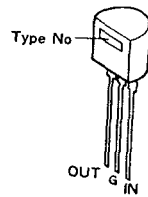

CXD1135Q

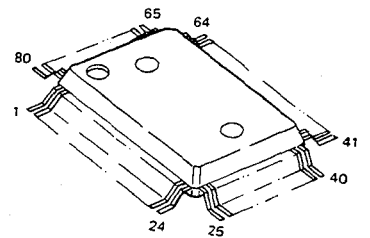

M5238PF  
TL082CP  
M5233P  
μPC4558C  
M5234P

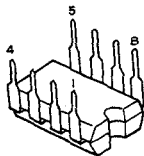

M74LS00P  
SN74LS00N  
TC4011BP  
PA0018  
IR2339  
M74LS27P  
SN74LS27N  
M74LS10P  
SN74LS10N

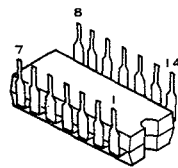

PCM56P-J  
TC40H004P  
TC4053BP  
PA0009  
PA9003  
HD74HC153P

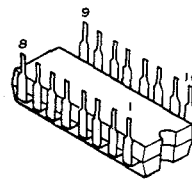

PD0024  
PM4001

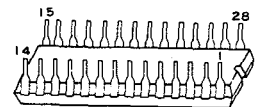

2SB1237X  
2SB1238X  
2SD1858X  
2SD1859X

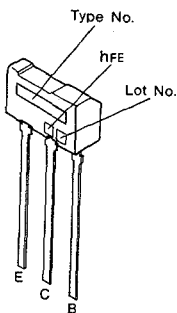

2SB1185  
2SD1762

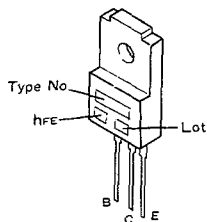



## 9. ELECTRICAL PARTS LIST

**NOTES:**

- Parts without part number cannot be supplied.
- Parts marked by "⊙" are not always kept in stock. Their delivery time may be longer than usual or they may be unavailable.
- The  $\Delta$  mark found on some component parts indicates the importance of the safety factor of the part. Therefore, when replacing, be sure to use parts of identical designation.
- For your parts Stock Control, the fast moving items are indicated with the marks **★ ★** and **★**.
- ★ ★ **GENERALLY MOVES FASTER THAN ★**  
This classification shall be adjusted by each distributor because it depends on model number, temperature, humidity, etc.
- When ordering resistors, first convert resistance values into code form as shown in the following examples.

Ex. 1 When there are 2 effective digits (any digit apart from 0), such as 560 ohm and 47k ohm (tolerance is shown by J = 5%, and K = 10%).

560Ω	56 × 10 <sup>1</sup>	561.....	RD1/4PS	⊠	⊠	⊠	J
47kΩ	47 × 10 <sup>3</sup>	473.....	RD1/4PS	⊠	⊠	⊠	J
0.5Ω	0R5.....		RN2H	⊠	⊠	⊠	K
1Ω	010.....		RS1P	⊠	⊠	⊠	K

Ex. 2 When there are 3 effective digits (such as in high precision metal film resistors).

5.62kΩ	562 × 10 <sup>1</sup>	5621.....	RN1/4SR	⊠	⊠	⊠	F
--------	-----------------------	-----------	---------	---	---	---	---

**Miscellaneous Parts**

**P.C. BOARD ASSEMBLIES**

Mark	Symbol & Description	Part No.
	DSDC assembly	VWG1010
	STBC assembly	VYV1013
	VDEM assembly	VYV1007
	DISP assembly	
	KEYB assembly	
	ADEM assembly	VYV1015
	MODB assembly	
	REGB assembly	VYR1019
	CAPB assembly	
	SENS assembly	
	CALB assembly	
	TIMB assembly	
	SRVB assembly	VYS1003
$\Delta$	LSFB assembly	
$\Delta$	PWSB assembly	

Mark	Symbol & Description	Part No.
★ ★	IC1 Control IC (LD SPINDLE MOTOR)	PA2016
★ ★	Q10 Transistor array (LD SPINDLE MOTOR)	STA302A
★ ★	Q11 Transistor array (LD SPINDLE MOTOR)	STA303A
★ ★	M3 Loading motor (for Slider)	VXM-054
★ ★	M5 Swing motor	VXM1007
★ ★	M2 Spindle motor assembly	VXX1047
★ ★	S6, S7 Slide switch (CD, LD MISS CLAMP)	VSK-010
★ ★	M6 Loading motor	VXM1006

**DSDC Assembly (VWG1010)**

**SEMICONDUCTORS**

Mark	Symbol & Description	Part No.
★ ★	IC404, IC407	BU4053B
★ ★	IC305	CXD1135Q
★ ★	IC304	CXK5816M-12L (CXK5816M-15L) (HM6116FP-2) (HM6116FP-3) (HM6116FP-4)
★ ★	IC101	HD6305Y2P
★ ★	IC401	HD74HC153P
★ ★	IC102, IC103	M5L8255AP
★ ★	IC403	M5238PF (NJM072DE)
★ ★	IC107	M74LS00P (SN74LS00N)
★ ★	IC108	M74LS10P (SN74LS10N)
★ ★	IC109	M74LS27P (SN74LS27N)
★ ★	IC302, IC303, IC306	NJM082D (TL082CP)
★ ★	IC405	NJM78L06A
★ ★	IC406	NJM79L06A
★ ★	IC402	PCM56P-J

**OTHERS**

Mark	Symbol & Description	Part No.
	Pick-up assembly	VWY1010
$\Delta$	AC Power cord	VDG-038
$\Delta$ ★ ★	FU103, FU104 Fuse (3A)	VEK-018
$\Delta$ ★ ★	FU1, FU2 Fuse (2A)	VEK-022
★ ★	S2 Slide switch (INTER LOCK)	VSK-012
$\Delta$ ★	T1 Power transformer	VTT-078
	C1, C2 Thru type capacitor (1000p)	VCG-005
★	VR1 Potentio meter	VCS-017
★ ★	S5 Slideswitch (CD MOTOR RELEASE)	VSK-010
★ ★	S4 Leaf switch (CD MOTOR SET)	VSK-014
★ ★	S3 Leaf switch (TILT LIMIT)	VSK-015 (PSN-003)
★ ★	IC111 EP-ROM	VYW1029
★ ★	M4 Tilt motor	VXM-060
★ ★	M1 Spindle motor (LD) (Incorporated in BLMB assembly)	VXM-063 (VXM-065)

Mark	Symbol & Description	Part No.	Mark	Symbol & Description	Part No.
★ ★	IC105	PD0024		C322	CFTXA103J50
★ ★	IC104	PD5029		C323, C405, C406, C413, C414, C417 – C420	CFTXA104J50
★ ★	IC301	TC40H004P		C312	CFTXA224J50
★ ★	Q104, Q108, Q305, Q309	RN1203 (DTC124ES)		C102, C114, C116, C122, C124, C126, C301	CGCYX473M25
★ ★	Q103	RN1209 (DTC144WS)		C131	CKCYB102K50
★ ★	Q306, Q402	RN2203 (DTA124ES)		C101, C302, C305, C311, C314 C117 – C119 C334 C303, C304	CKCYF103Z50 CKDYF103Z50 CKPUYF223Z25 CQMA102J50
★ ★	Q101, Q308	2SA933S		C307	CQMA152J50
★ ★	Q102, Q107, Q109, Q112, Q301, Q302	2SC1740S		C328, C329	CQMA222J50
★ ★	Q303, Q304, Q307	2SK184		C308	CQMA472J50
★	D306	FC54M		C321	CQMA822J50
★	D311, D314	HZ4B2		C415, C416 (150pF)	VCE1007
★	D309	KV1226Y		VC101 Ceramic trimmer (45pF)	VCM-003
★	D103, D104, D301 – D304, D307, D308, D310, D312, D313, D401 – D404	1SS254			

**COILS AND FILTERS**

Mark	Symbol & Description	Part No.
	L302 Coil (1μH)	LAU010K
	L101 Coil (220μH)	LAU221J
	VL301 VCO coil	PTL-023
	L301 Coil (4.7μH)	VTL1003
	F401, F402 Low pass filter	VTF1010
	F101 3 terminal filter	VTH-005

**CAPACITORS**

Mark	Symbol & Description	Part No.
	C107	CCCCH100D50
	C105	CCCCH180J50
	C103, C104, C106, C111, C407	CCCCH330J50
	C108	CCCCH470J50
	C317	CCCCH560J50
	C109, C110, C306	CCCSL151J50
	C128	CCCSL220J50
	C318	CCCSL391J50
	C326	CCCUJ221J50
	C325, C327	CCCUJ330J50
	C324	CEANP2R2M50
	C421, C422	CEANP220M16
	C309, C310, C330 – C332	CEAS010M50
	C315, C333	CEAS100M50
	C320	CEAS101M10
	C409 – C412	CEAS101M25
	C127	CEAS221M10
	C401 – C404	CEAS221M25
	C113, C319	CEJA101M6R3
	C115, C121, C123, C125	CEJA470M6R3

**RESISTORS**

Mark	Symbol & Description	Part No.
★	VR301 – VR303 Semi-fixed (22kΩ)	VRTB6VS223
	R145 Resistor array	RA4S103J
	R130 Resistor array	RA6S332J
	R148 Resistor array	RA8S103J
	R336, R338, R349, R350	RN1/6P□□□□□F
	Other resistors	RD1/6PM□□□J

**OTHERS**

Mark	Symbol & Description	Part No.
★	X101 Ceramic resonator (4MHz)	KBR-4.0MS
★	X102 Ceramic resonator (400kHz)	VSS-041
★	X301 Crystal resonator (16MHz)	VSS1004
★	X103 Crystal resonator (14.31818MHz)	VSS1005 (VSS-043)
	IC socket (28 Pin)	VKH1001

**STBC Assembly (VYV1013)**

**SEMICONDUCTORS**

Mark	Symbol & Description	Part No.
★ ★	IC2, IC3, IC102, IC201	BA4558DX (NJM4558D)
★ ★	IC203	BU4053B (TC4053BP)
★ ★	IC202	M5233P
★ ★	IC4	PA0009
★ ★	IC1	PA5009
★ ★	IC301	PA9003
★ ★	IC101	PM2001
★ ★	IC204	TC4011BP

Mark	Symbol & Description	Part No.	Mark	Symbol & Description	Part No.
★ ★	Q3, Q4, Q106, Q107, Q201 – Q205, Q211	RN1203		C22	CQMA102J50
★ ★	Q206	RN2203		C6, C204	CQMA103J50
★ ★	Q5, Q101, Q102, Q301, Q304	2SA933S		C3, C308	CQMA104J50
★ ★	Q403, Q409	2SC1583		C9, C13, C15, C16	CQMA122J50
				C104, C107	CQMA123J50
★ ★	Q6, Q103 – Q105, Q207, Q210, Q302, Q303, Q305 – Q307, Q401, Q402, Q404 – Q408, Q410 – Q414	2SC1740S		C29, C31	CQMA153J50
				C109	CQMA183J50
★ ★	Q1, Q2	2SK184		C14	CQMA222J50
				C112	CQMA223J50
				C1	CQMA273J50
★	D301	SVC321SP		C408	CQMA392J50
★	D1 – D3, D6 – D12, D101 – D106, D201, D401 – D404	1SS254		C5	CQMA393J50
★	TH201 Thermistor	112252		C418	CQMA512J50
				C10, C12	CQMA682J50
				C37, C205	CQMA823J50
				C11	CQPA122J100

**COILS AND FILTERS**

Mark	Symbol & Description	Part No.
	L2 Coil (120μH)	LRA121K
	L1 Coil (27μH)	LRA270K
	L301 Coil (6.8μH)	LRA6R8K
	F401 Filter (3.58MHz)	VTF-062

**CAPACITORS**

Mark	Symbol & Description	Part No.
	C406	CCCCH080D50
	C407	CCCCH150J50
	C19, C105	CCCCH680J50
	C17, C21, C35	CCCCL101J50
	C409	CCCCL151J50
	C401	CCCCL161J50
	C410	CCCCL181J50
	C110, C115	CCCCL221J50
	C28	CCCCL241J50
	C32, C33, C306, C415	CCCCL331J50
	C27	CCDCH470J50
	C403	CCDSL221J50
	C30, C307	CEANPR47M50
	C8, C425, C426	CEANP100M16
	C2	CEANP2R2M50
	C103	CEANP330M6R3
	C106	CEANP470M10
	C202, C203	CEASR47M50
	C111, C114	CEAS100M50
	C315, C413, C414, C417	CEAS101M10
	C23, C25, C41, C312, C424	CEAS221M10
	C7, C316	CEAS4R7M50
	C101, C108, C206, C301, C314, C317, C419, C420, C423	CEAS470M25
	C305	CEJA470M16
	C302, C310	CKCYB102K50
	C18, C34, C36	CKCYB681K50
	C4, C20, C24, C26, C102, C113, C207, C304, C311, C313, C404, C405, C411, C412, C416, C421, C422	CKCYF103Z50

**RESISTORS**

Mark	Symbol & Description	Part No.
★	VR301 Semi-fixed (1kΩ)	VRTB6VS102
★	VR2 Semi-fixed (22kΩ)	VRTB6VS223
★	VR5 Semi-fixed (4.7kΩ)	VRTB6VS472
★	VR1, VR3, VR4 Semi-fixed (47kΩ)	VRTB6VS473
	R137, R212 – R214	RN1/6PQ□□□□F
	Other resistors	RD1/6PM□□□□J

**VDEM Assembly (VYV1007)**

**SEMICONDUCTORS**

Mark	Symbol & Description	Part No.
★ ★	IC601	PA0017
★ ★	IC603	PA0018
★ ★	IC501	PA0023
★ ★	IC502	PA3018
★ ★	IC503	PM0001
★ ★	IC602	TL8707P
★ ★	Q508	DTA124ES
★ ★	Q507, Q509	RN2203
★ ★	Q503, Q603	2SA933S
★ ★	Q602	2SC1627
★ ★	Q501	2SC1674
★ ★	Q502, Q506, Q510 – Q516, Q601, Q604 – Q607	2SC1740S
★	D602	MTZ10B
★	D601	MTZ8.2C
★	D501, D502	1SS254

**COILS**

Mark	Symbol & Description	Part No.
L506	Inductor	LAU390J
L507	Inductor	LAU430J
L502 – L505	Inductor	LRA120K
L501	Inductor	LRA180K
L508, L601, L603, L604	Inductor	LRA220K
L511	Inductor	LRA221K
L509, L510	Inductor	LRA391K
L602	Inductotr	LRA680K
L512, L513	Coil (62μH)	VTL-048

**CAPACITORS**

Mark	Symbol & Description	Part No.
C522, C523, C531		CCCCH080D50
C510, C512		CCCCH100D50
C623		CCCCH120J50
C525, C530		CCCCH150J50
C526, C558		CCCCH180J50
C559		CCCCH220J50
C565		CCCCH240J50
C511, C524, C605		CCCCH330J50
C535, C544, C621		CCCCH390J50
C520		CCCCH680J50
C622		CCCCH750J50
C501, C506, C507, C563, C564		CCCCH820J50
C560		CCCCL121J50
C533		CCCCL151J50
C527, C546, C547		CCCCL181J50
C504		CCCCL221J50
C562		CCCCL241J50
C508		CCCCL271J50
C536, C634		CCCCL331J50
C509		CCCCL391J50
C561, C635		CEANP4R7M25
C624		CEANP470M10
C606, C611		CEASR47M50
C615, C618, C639		CEAS010M50
C542, C543, C575, C602, C604, C608, CEAS220M50		
C610, C616, C625, C628, C629, C631, C633		
C548, C554		CEAS3R3M50
C528, C613, C614, C619		CEAS4R7M50
C503, C515, C517, C521, C539, C541, CEAS470M25		
C550, C552, C568, C572, C574, C641, C643		
C636, C640		CEJA220M16
C502, C553, C577		CGCYX473M25
C532, C534		CKCYB102K50
C505, C513, C514, C516, C518, C519, CKCYF103Z50		
C529, C537, C538, C540, C549, C551, C555 – C557, C566, C567, C569 – C571, C573, C576, C601, C603, C607, C609, C612, C617, C626, C627, C630, C642, C644, C646		
C638		CQMA124J50
C637		CQPA271J100

**RESISTORS**

Mark	Symbol & Description	Part No.
★	VR501, VR602 Semi-fixed (1kΩ)	VRTB6VS102
★	VR601, VR603 Semi-fixed (4.7kΩ)	VRTB6VS472
	R557, R522	RD1/4VM□□□J
	R543	RN1/6PQ2401F
	Other resistors	RD1/6PM□□□J

**OTHERS**

Mark	Symbol & Description	Part No.
	DL501 220n sec Delay line	VTF-063
	F601 – F603 3 terminal filter	VTH-005

**DISP Assembly**

**SEMICONDUCTORS**

Mark	Symbol & Description	Part No.
★ ★	IC1	PD0012A
★ ★	Q1	DTC124ES
★ ★	Q2 – Q4	2SB808
★	D11	LB-402DB4
★	D6 – D10 LED (ORANGE)	SLH-56DC3
★	D4, D5 LED	SLH-56DC3H
★	D1 – D3 LED	SLV-31DC3

**CAPACITORS**

Mark	Symbol & Description	Part No.
	C1	CEJAR47M50
	C2	CEJA470M6R3

**RESISTORS**

Mark	Symbol & Description	Part No.
	All resistors	RD1/6PM□□□J

**KEYB Assembly**

**SEMICONDUCTORS**

Mark	Symbol & Description	Part No.
★ ★	IC101	PD0012A
★	D101 – D103, D106 LED	SLH-56DC3H
★	D104, D105 LED (ORANGE)	SLV-56DC3

**SWITCHES**

Mark	Symbol & Description	Part No.
★ ★	S101 – S106 Tact switch (OPEN/CLOSE, PLAY/PAUSE, SCAN FWD, SCAN REV, SKIP FWD, SKIP REV)	VSC-010

**CAPACITORS**

Mark	Symbol & Description	Part No.
	C101	CEJAR47M50
	C102	CEJA101M6R3
	C103	CEJA470M6R3

**RESISTORS**

Mark	Symbol & Description	Part No.
	All resistors	RD1/6PM□□□J

**OTHERS**

Mark	Symbol & Description	Part No.
	IR Sensor unit	VXX1021

**ADEM Assembly (VYV1015)**

**SEMICONDUCTORS**

Mark	Symbol & Description	Part No.
★ ★	IC1	PA0026
★ ★	IC101	TA7347P
★ ★	Q10	RN1203
★ ★	Q4	RN2203
★ ★	Q1 – Q3	2SA933S
★ ★	Q5 – Q9, Q101 – Q108	2SC1740S
★	D1	MTZ5.6C
★	D2 – D5	1SS254

**RELAY**

Mark	Symbol & Description	Part No.
★ ★	RY1 Relay	VSR-005

**COIL AND FILTERS**

Mark	Symbol & Description	Part No.
	L101 Coil (3.9mH)	VTL-170
	F101 Low pass filter	VTF-060
	F1 B.P.F (2.3MHz)	VTF1002
	F2 B.P.F (2.8MHz)	VTF1003

**CAPACITORS**

Mark	Symbol & Description	Part No.
	C102	CCCCH121J50
	C38	CCCCH181J50
	C8, C20, C48	CCCCH221J50
	C34, C103	CCCCH330J50
	C4	CCCCH390J50
	C18, C47	CCCCH560J50
	C24	CEANLR47K50
	C26	CEANL220K16
	C9, C39	CEANP220M16
	C55	CEASR47M50
	C66	CEAS010M50
	C19, C21, C29, C49, C59 – C61, C101, C106, C108, C113	CEAS100M50
	C7, C37, C58, C63, C114	CEAS101M10
	C30, C54	CEAS220M50
	C65, C109	CEAS2R2M50

Mark	Symbol & Description	Part No.
	C6, C36	CEAS221M10
	C15	CEAS4R7M50
	C53, C111	CEAS470M25
	C5, C27, C35, C62	CEAS471M10
	C112	CGCYX473M25
	C14, C44, C67 – C69	CKCYB102K50
	C16, C45	CKCYB472K50
	C105, C110	CKCYF103Z50
	C1 – C3, C31 – C33, C56, C70	CKCYF223Z50
	C25, C57	CQMA104J50
	C10, C11, C40, C41	CQMA112J50
	C17, C46	CQMA152J50
	C13, C43	CQMA222J50
	C23, C51	CQMA393J50
	C22, C50	CQMA822J50
	C104	CQSA471J50
	C107	CQSA821J50

**RESISTORS**

Mark	Symbol & Description	Part No.
	R116	RN1/6PQ6201F
	R22, R10, R39, R40	RD1/4VM□□□J
	Other resistors	RD1/6PM□□□J

**OTHERS**

Mark	Symbol & Description	Part No.
	JA1 4P Pin jack	VKB-019
	JA3 2P Mini jack	VKN-183
	JA2 Video pin jack	VKB-014

**MODB Assembly**

**OTHERS**

Mark	Symbol & Description	Part No.
	RFMD	VWL1002

**REGB Assembly (VYR1019)**

**SEMICONDUCTORS**

Mark	Symbol & Description	Part No.
★ ★	IC3	BA4558DX
★ ★	IC1	NJM7812A
★ ★	IC2	NJM7912A
★ ★	Q6, Q8	2SA933S
★ ★	Q4, Q5	2SB1185
★ ★	Q10	2SC1627
★ ★	Q7, Q9	2SC1740S
★ ★	Q11	2SD1267
★ ★	Q1 – Q3	2SD1762
★	D3, D4	HZ5B3
★	D1, D2	MTZ11A
★	D11	RB-152LF
★	D13	S2K20
★	D7, D8	1SR35-100AVL
★	D5, D6, D9, D10, D12, D19, D20	1SS254

**COIL**

Mark	Symbol & Description	Part No.
L1	Coil	VTT-070

**CAPACITORS**

Mark	Symbol & Description	Part No.
C32		CCCSL471J50
C1, C2		CEAS010M50
C9, C10, C12, C15 – C18, C29, C30, C33, C36		CEAS100M50
C3, C4		CEAS101M25
C21		CEAS220M50
C20		CEAS3R3M50
C14		CEAS330M25
C13		CEAS470M25
C26		CEAS470M50
C31		CKCYB102K50
C5 – C8, C11, C19, C27, C28, C35		CKCYF103Z50

**RESISTORS**

Mark	Symbol & Description	Part No.
R18	(2.7Ω/1W)	VCN-100
R19	(1.2Ω/3W)	VCN-131
R20 – R23		RN1/6PQ2202F
	Other resistors	RD1/6PM□□□J

**CAPB Assembly**

**SEMICONDUCTORS**

Mark	Symbol & Description	Part No.
★ D109		RB-152LF
★ D101 – D104		1SR35-100AV/L
★ D105 – D108		10DF1

**CAPACITORS**

Mark	Symbol & Description	Part No.
C101 – C106		CEAS222M25
C107 – C109		CEAS472M10
C110 – C113		CKCYF103Z50

**SENS Assembly**

**SEMICONDUCTORS**

Mark	Symbol & Description	Part No.
★★ Q3, Q4		DTC124EF
★★ Q1, Q2	Photo transistor	PH101
★ D1, D2	LED	SIR-56ST3H

**RESISTORS**

Mark	Symbol & Description	Part No.
	All resistors	RD1/6PM□□□J

**OTHERS**

Mark	Symbol & Description	Part No.
	Sensor holder	VNL-613

**CALB Assembly**

**SEMICONDUCTORS**

Mark	Symbol & Description	Part No.
★★ IC1		BA6209
★ D1		MTZ 8.2A

**CAPACITORS**

Mark	Symbol & Description	Part No.
C1		CEAS470M25
C2, C3		CGDYX473M25

**RESISTOR**

Mark	Symbol & Description	Part No.
R1		RD1/6PM220J

**OTHERS**

Mark	Symbol & Description	Part No.
★★ S1	Rotary encoder	VSD1001

**TIMB Assembly**

**CAPACITORS**

Mark	Symbol & Description	Part No.
	C201 – C203	CGCYX473M25

**SRVB Assembly (VYS1003)**

**SEMICONDUCTORS**

Mark	Symbol & Description	Part No.
★★ IC1 – IC6		BA4558DX (μPC4558C)
★★ IC13		BA6218A
★★ IC11		IR2339 (M5234P)
★★ IC9		NJM082D (TL082CP)
★★ IC7		NJM4556DE
★★ IC14		NJU4053BD (BU4053BD)
★★ IC8		PM4001
★★ IC12		TA7256P
★★ Q24, Q29, Q33, Q34		RN1203 (DTC124ES)
★★ Q10, Q31, Q36		RN2203 (DTA124ES)
★★ Q7		2SA886
★★ Q11		2SA933S
★★ Q15, Q23		2SB1237X
★★ Q28		2SB1238X
★★ Q1, Q3, Q12, Q14, Q26, Q30		2SC1740S
★★ Q6		2SC1847
★★ Q22		2SD1858X
★★ Q27		2SD1859X
★★ Q5, Q9, Q17		2SK184

Mark	Symbol & Description	Part No.
★	D6, D7	MTZ3.6A
★	D9	MTZ5.6C
★	D1, D2, D5, D8, D11, D12, D15 – D26	1SS254
★	TH1 Thermistor	112252

**CAPACITORS**

Mark	Symbol & Description	Part No.
	C81	CCPUSL680J50
	C20, C44	CEALNPR47M50
	C5, C51, C78	CEALNP010M50
	C61	CEALNP220M16
	C23, C56	CEALNP3R3M25
	C17, C48, C59	CEALNP4R7M35
	C21	CEALR47M50
	C3, C19, C31, C32, C34, C65, C72	CEAL010M50
	C24, C26, C36, C39, C74	CEAL100M16
	C37, C46, C47	CEAL470M16
	C64, C73, C86	CFTA104J50
	C52	CFTA124J50
	C11	CFTA224J50
	C4, C53, C55	CFTA473J50
	C58	CFTA683J50
	C1, C2, C15, C25, C27, C35, C38, C42, C43, C45, C57, C62, C67 – C70, C75, C76, C79, C80, C83 – C85	CKCYF103Z50
	C9, C16	CKPUYB101K50
	C60	CKPUYB331K50
	C18, C22	CQMA102J50
	C50	CQMA152J50
	C6	CQMA223J50
	C41	CQMA273J50
	C49	CQMA332J50
	C12	CQMA333J50
	C13	CQMA392J50
	C14, C54	CQMA472J50
	C28	CQMA682J50

**RESISOTRS**

Mark	Symbol & Description	Part No.
★	VR3 Semi-fixed (10kΩ)	VRTB6VS103
★	VR6, VR8 Semi-fixed (2.2kΩ)	VRTB6VS222
★	VR1, VR10, VR12 Semi-fixed (22kΩ)	VRTB6VS223
★	VR2, VR5, VR9, VR11 Semi-fixed (4.7kΩ)	VRTB6VS472
★	VR4 Semi-fixed (47kΩ)	VRTB6VS473
	R159	RD1/2PMF220J
	R73	RD1/4PMF470J
	R102	RD1/4PM6R8J
	R145 Fusible resistor	RFA1/4L470J
	R166	RN1/6PQ3R90F
	R168	RS1PF4R7J
	Other resistors	RD1/6PM□□□J

**OTHERS**

Mark	Symbol & Description	Part No.
	CN61 18P connector	VKN-192

**LSFB Assembly**

**FILTER**

Mark	Symbol & Description	Part No.
△	L1 Line filter	VTL-003

**CAPACITORS**

Mark	Symbol & Description	Part No.
△	C1, C2 Ceramic capacitor (0.01μF)	VCG-048 (VCG-018)

**RESISTOR**

Mark	Symbol & Description	Part No.
	R1	RD1/2VM225J

**PWSB Assembly**

**SWITCH**

Mark	Symbol & Description	Part No.
△ ★★	S1 Power switch	VSA-010

**CAPACITOR**

Mark	Symbol & Description	Part No.
△	C3 Ceramic capacitor (0.01μF)	VCG-048 (VCG-018)

## 10. HOW TO REPLACE THE PICK-UP ASSEMBLY?

### • Removing the Mechanical Assembly

1. Remove the bottom plate (by removing the ten screws). (Figure 10-1)
2. Remove the four screws securing the DSDC assembly, then remove the two screws securing the STBC assembly, then open the board. (Fig. 10-2)
3. Remove the six connectors from the SRVB assembly and the BLMB assembly. (Fig. 10-3)  
 SRVB assembly ... CN9, CN10, CN11, CN12, CN13  
 BLMB assembly ... CN48
4. Remove the three (A) screws shown in Fig. 10-3 from the Mechanical assembly and remove the two (B) screws shown in Fig. 10-3 from the SRVB assembly.
5. Remove the Mechanical assembly together with the SRVB assembly.

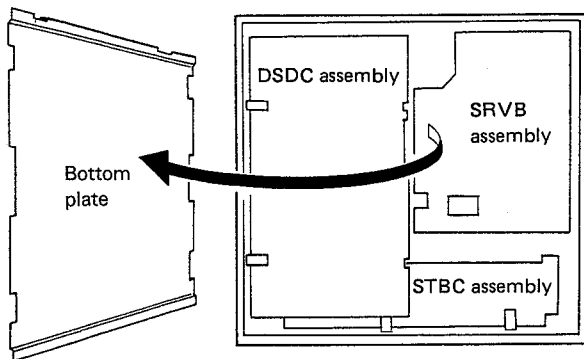

Fig. 10-1

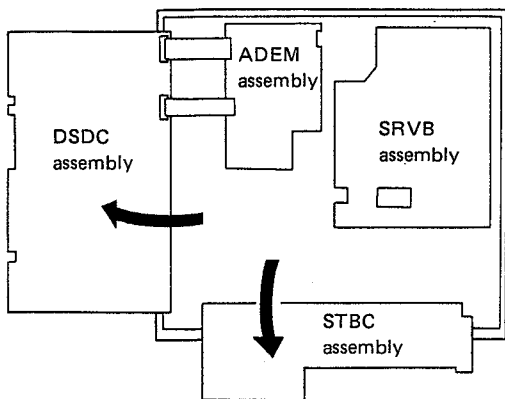

Fig. 10-2

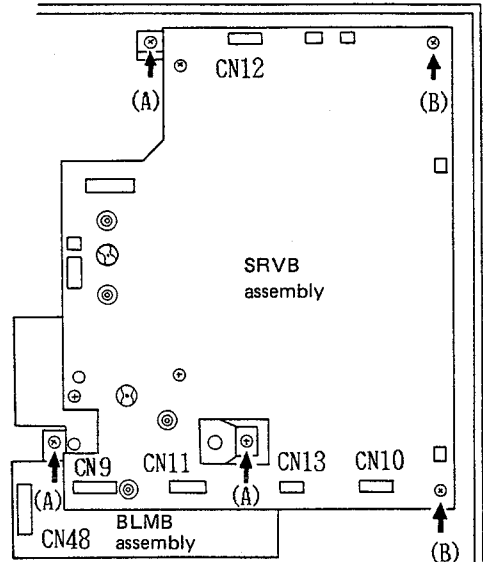

Fig. 10-3

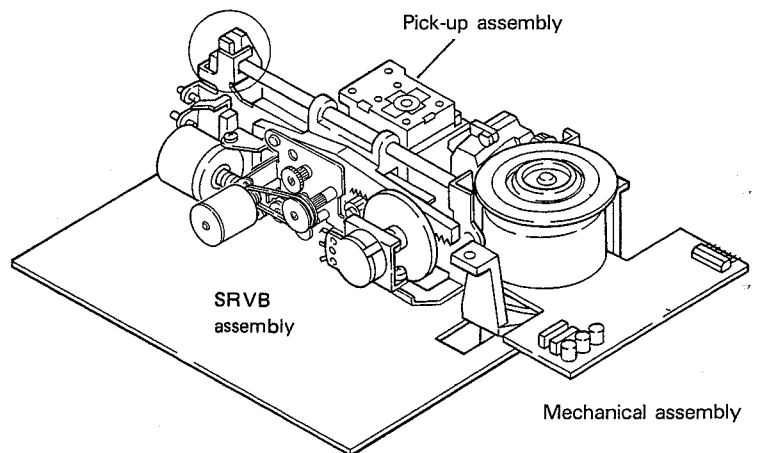

Fig. 10-4



• Replacing the Pick-up assembly

6. Move the Pick-up assembly by hand all the way to the edge.
  7. Remove the flexible cable from connector CN61 on the SRVB assembly, then remove the two screws securing the Pick-up assembly.
- Note: Be careful not to bend or fold the flexible cable. (Fig. 10-5)

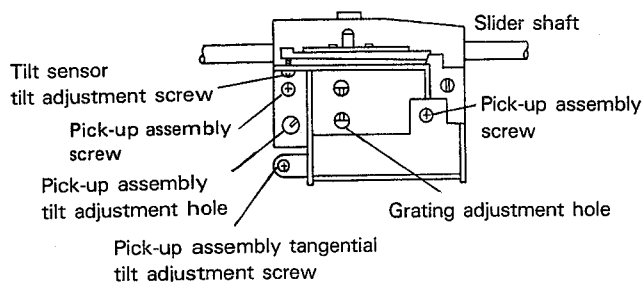

Fig. 10-5

8. Remove the Pick-up assembly from the Mechanical assembly.
- Note:  
Be careful not to apply electrical external force on the Pick-up assembly. Therefore do not, for example, touch the flexible cable with your hand or shine outside light on the Tilt sensor.
9. Adjust the Tilt sensor tilt adjustment screw on the new Pick-up assembly so that the Tilt sensor and the sensor stay are parallel. (Fig. 10-6)

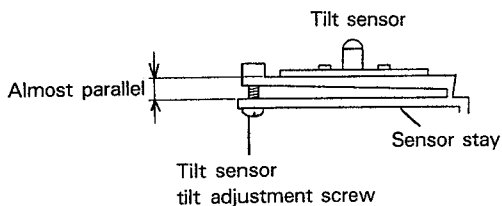

Fig. 10-6

10. Install the new Pick-up assembly on the Mechanical assembly, turn it all the way clockwise, then tighten the Pick-up assembly screw slightly. Skipping this step can make it quite difficult to adjust the tilt of the Pick-up assembly later.
11. Turn the worm gear of the tilt motor so that the tilt base is at the same height as the top of the chassis of the Mechanical assembly. (Fig. 10-7, 10-8)

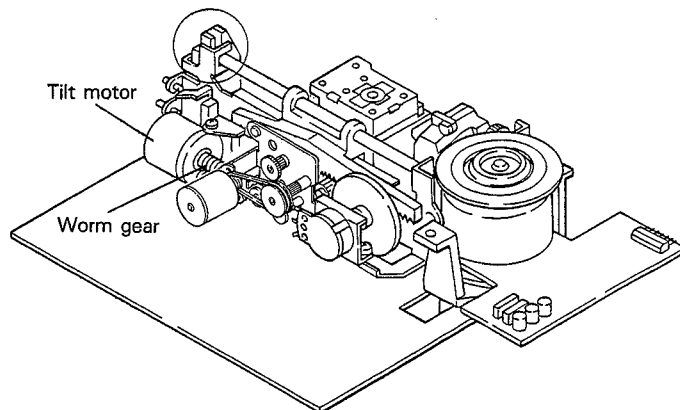

Fig. 10-7

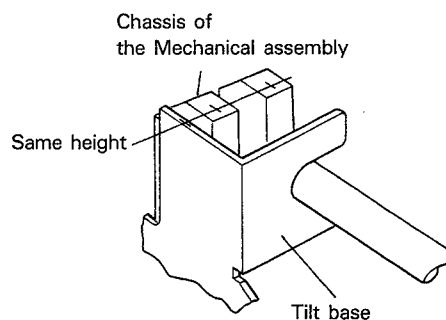

Fig. 10-8

12. Install the Mechanical assembly in the disc player, tighten the three (A) screws and two (B) screws shown in Figure 10-3, connect the ground, then connect the connectors.
  13. Leave connector CN53 on the SRVB assembly unconnected.
- This completes the replacement of the Pick-up assembly. Carry out the following adjustments:
- Rough grating adjustment
  - Pick-up assembly tilt adjustment (1)
  - Pick-up assembly tilt adjustment (2)
  - Tilt sensor tilt adjustment
  - LD spindle motor axis centering
  - Grating fine adjustment
  - CD spindle motor tilt adjustment
  - CD spindle motor axis centering
  - LD/CD disc clamp switching position adjustment
  - Rotary encoder adjustment
  - Synchronization belt adjustment
  - Roller plate (right) assembly adjustment
  - Subcarrier assembly, slide plate and gear (C) alignment
  - Carrier insertion

# 11. MECHANICAL ADJUSTMENT

• Preparations for Adjustment

List of the tools required for adjustments			
1	Dual trace oscilloscope	11	2.5-mm hexagonal L-wrench
2	AF oscillator	12	Pick-up assembly tilt adjuster (GGF-064)
3	Voltmeter		
4	Frequency counter		
5	TV monitor		
6	Remote control unit		
7	LD test disc	13	1.5V battery and leads
8	CD test disc (YEDS-7)		
9	Angled Screwdriver I (GGV-129)		
10	Angled Screwdriver II (GGF-063)		

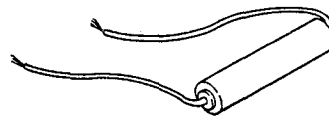
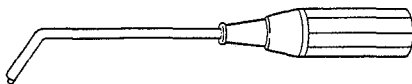
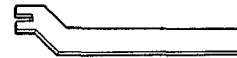

• Precautions for adjustments

1. Always have the disc player resting flat before mounting a disc. To stop the rotation of the spindle motor, just press the EJECT key on the remote control unit once.

Note: Pressing the EJECT key on the front panel stops the rotation of the spindle motor and extends the disc table from the player.

2. Standing the disc player as shown in Fig. 11-1.
3. Use the 10:1 probe for the oscilloscope.

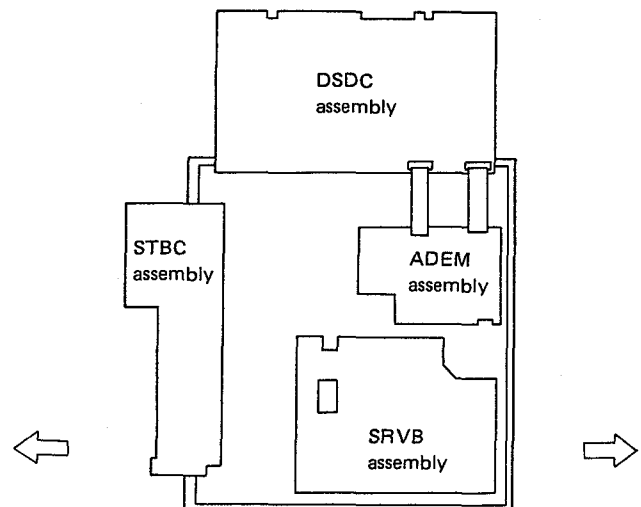

Fig. 11-1

11.1 ROUGH GRATING ADJUSTMENT

Mechanical Adjustments

- Objective: To adjust the grating, which is out of adjustment for a new Pick-up assembly
- Symptoms if the adjustment is inadequate: Discs can not be played back and the Pick-up skips over tracks.

- |   |   |
|---|---|
| <ul style="list-style-type: none"> <li>● Measuring equipment and tools</li> <li>● Measurement point</li> <li>● Test disc and set</li> <li>● Adjustment point</li> </ul> | <ul style="list-style-type: none"> <li>● Oscilloscope</li> <li>● Angular Screwdriver I (GGV-129)</li> <li>● TV monitor</li> <li>● CN102-1 (tracking error) on the SRVB assembly</li> <li>● Play the LD disc near frame # 50,000 (outer edge)</li> <li>● Tracking servo open</li> <li>● Grating</li> </ul> |
|---|---|

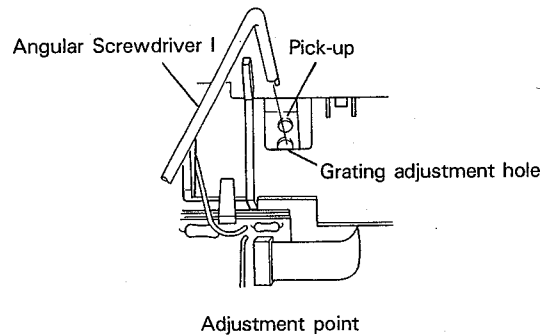
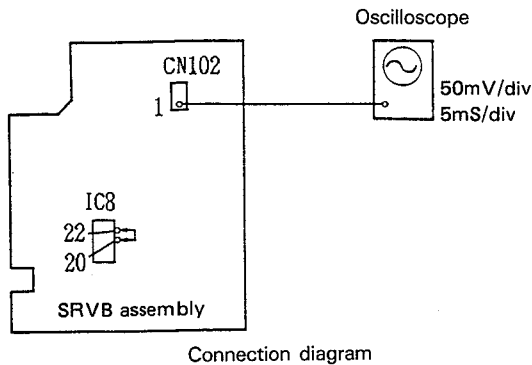

**Adjustment procedure**

1. Mount the LD disc, then press the play key.
2. When the spindle motor has reached full speed, connect Pins 20 and 22 of IC8 (PM4001) on the SRVB assembly (to open the tracking servo).
3. Press the remote control display switch key to display the frame number on the screen.
4. Press the fast feed key on the remote control to send the Pick-up assembly to around Frame # 50,000 on the outer edge.
5. Connect the oscilloscope to CN102-1 (tracking error) of the SRVB assembly.
6. Insert Angular Screwdriver I into the grating adjustment hole. Turn the screwdriver slowly to the position at which the amplitude of the wave form is a minimum and the waves are smooth. (Photograph 1) Turn Angular Screwdriver I slowly clockwise in the direction of the front panel and stop at the first maximum for the wave form. (Photograph 2)
7. Remove the connection between Pins 20 and 22 of IC8 (PM4001) of the SRVB assembly to close the tracking servo, then check that the image on the TV screen is normal.

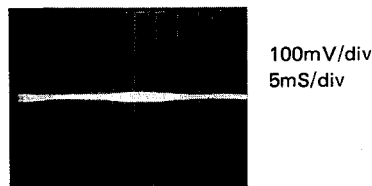

Photograph 1  
On Track Position

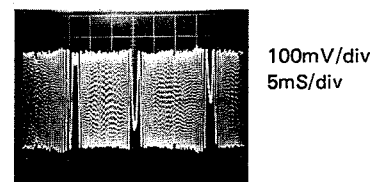

Photograph 2  
Maximum Amplitude

11.2 PICK-UP ASSEMBLY TILT ADJUSTMENT (1)

Mechanical Adjustments

- Objective: To adjust the position of the slider shaft so that the Pick-up assembly moves parallel to the disc
- Symptoms if the adjustment is inadequate: Cross talk

- |   |   |
|---|---|
| <ul style="list-style-type: none"> <li>● Measuring equipment and tools</li> <li>● Measurement point</li> <li>● Test disc and set</li> <li>● Adjustment point</li> </ul> | <ul style="list-style-type: none"> <li>● Oscilloscope</li> <li>● 1.5 V battery</li> <li>● Leads</li> <li>● L.P.F.</li> <li>● SRVB assembly CN102-5</li> <li>● Still frame at frame #17,000 (middle) and still at Frame #100 (inner edge)</li> <li>● SRVB assembly tilt motor</li> </ul> |
|---|---|

Pick-up assembly tilt

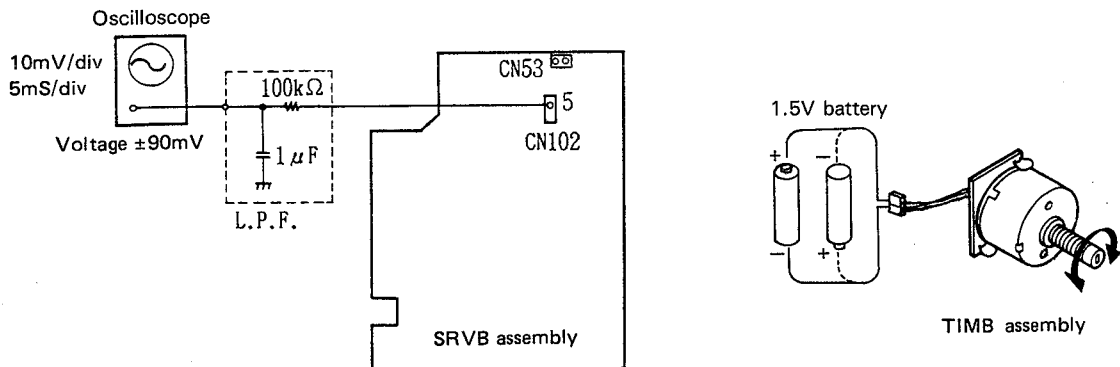

Connection diagram

**Adjustment Procedure**

1. Connect the oscilloscope to SRVB assembly CN102-5 (focus coil) through the L.P.F. (100 kΩ: 1 μF). Set the range of the oscilloscope to 10 mV/division and 5 ms/division.
2. Play the LD test disc.
3. Find Frame #17,000. Use the horizontal adjustment on the oscilloscope to center the wave form from CN102-5 of the SRVB assembly.
4. Find Frame #100. Make sure that the voltage at SRVB assembly CN102-5 is between -90mV and +90mV.
5. If the voltage measured in (4) is not between -90mV and +90mV, disconnect the connector for the tilt motor from CN53 of the SRVB assembly, then connect the leads for the 1.5 V battery to the tilt motor. Turn the motor until the voltage measured with the oscilloscope is between -90mV and +90mV. To turn the motor the other way, reverse the leads from the 1.5V battery.

## 11.3 PICK-UP ASSEMBLY TILT ADJUSTMENT (2)

## Mechanical Adjustments

- Objective: To have the Pick-up assembly installed parallel to the disc
- Symptoms if the adjustment is inadequate: Cross talk

- Measuring equipment and tools
- Measurement point
- Test disc and set

- TV monitor • Pick-up assembly tilt adjuster (GGF-064)
- LD test disc F series ... #42,314, #104 still    N1 ... #46,135, #115 still
- Adjustment point
- Pick-up assembly angle

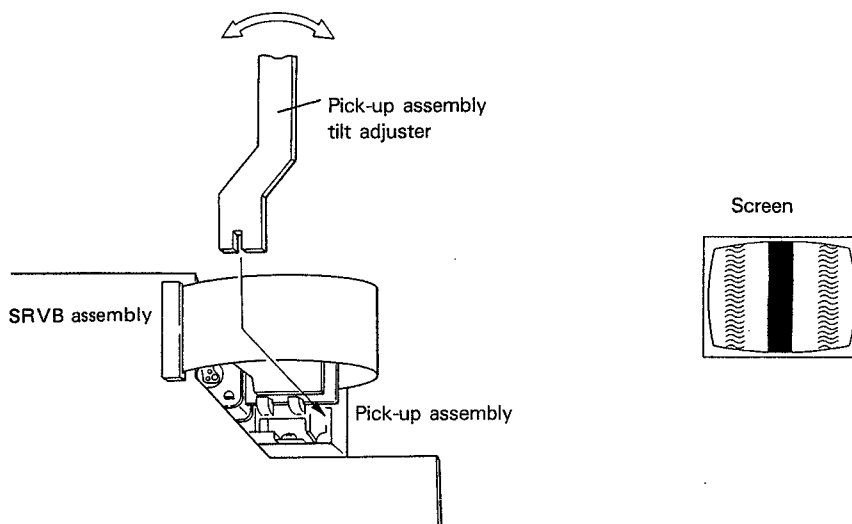
**Adjustment Procedure**

- Leave the CN53 connector disconnected.
1. Find Frame #42,314 (#46,135).
  2. Use the Pick-up assembly adjuster (GGF-064) as shown in the diagram to adjust the Pick-up assembly angle to the position that minimizes the cross talk on the screen.
  3. Find Frame #104 (#115) and check that the cross talk is not noticeable. If there is cross talk, repeat Steps 1 through 3.
  4. Remove the mechanical assembly from the disc player, tighten down the two screws securing the Pick-up assembly, then reinstall the mechanical assembly in the disc player.

11.4 TILT SENSOR TILT ADJUSTMENT

Mechanical Adjustments

- Objective: To adjust the tilt of the tilt sensor so that its electrical offset is 0V
- Symptoms if the adjustment is inadequate: Cross talk

- Measuring equipment and tools
- Measurement point
- Test disc and set
- Adjustment point

- Oscilloscope
- Philips screwdriver
- Pin 1 of IC9 (TL082CP) on the SRVB assembly
- LD test disc F series ... #104 still N1 ... #115 still
- Tilt sensor adjustment screw

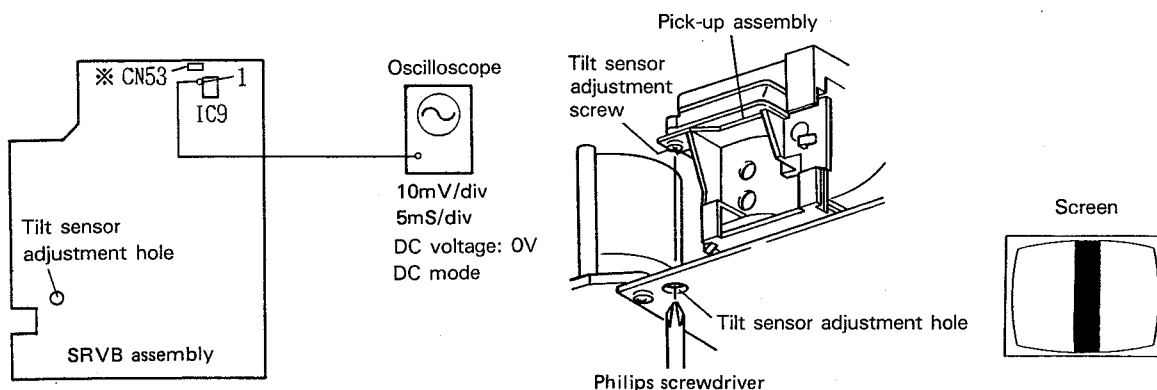

Connection diagram

Pick-up assembly adjustment point

**Adjustment Procedure**

\*Leave the CN53 connector disconnected (to disconnect the tilt servo).

1. Play back the LD test disc and check that the cross talk is minimal at Frame # 18,914 (# 22,525). If there is excessively cross talk, repeat the Pick-up assembly tilt adjustments (1) and (2).
2. Find Frame # 104 (# 115).
3. Connect the oscilloscope to Pin 1 of IC9 (TL082CP) on the SRVB assembly. Adjust the tilt sensor adjustment screw so that the DC voltage is 0 V.
4. Connect CN53 of the SRVB assembly.
5. Double check that there is no cross talk at Frames # 104 (# 115), # 18,914 (# 22,525), and # 42,314 (# 46,135). If there is cross talk, repeat the Pick-up assembly tilt adjustments (1) and (2).

11.5 LD SPINDLE MOTOR AXIS CENTERING

Mechanical Adjustments

- Objective: To align the position of the motor so that the Pick-up assembly moves on the horizontal line of the center of the LD spindle motor
- Symptom if the adjustment is inadequate: Track skipping, excessively long search times

- |   |   |
|---|---|
| <ul style="list-style-type: none"> <li>• Measuring equipment and tools</li> <li>• Measurement point</li> <li>• Test disc and set</li> <li>• Adjustment point</li> </ul> | <ul style="list-style-type: none"> <li>• Oscilloscope</li> <li>• Angular Screwdriver I (GGV-129)</li> <li>• SRVB assembly</li> <li>• CN102-1 (tracking error)</li> <li>• CN103-6 (tracking sum)</li> <li>• Tracking servo open</li> <li>• Play at the inner and outer edges of the LD test disc</li> <li>• Grating</li> <li>• LD spindle motor</li> </ul> |
|---|---|

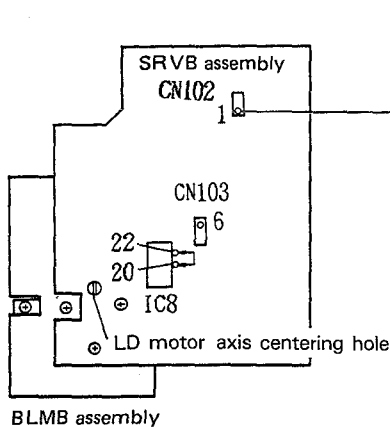

Connection diagram (1)

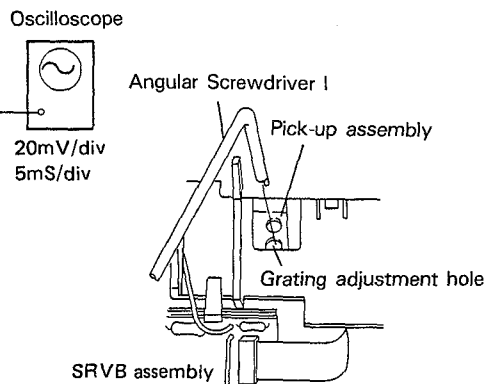

Adjustment points

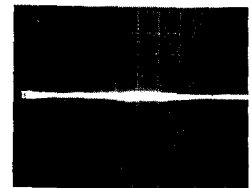

Photograph 1  
Tracking Error Wave Form  
Open Loop On Track State

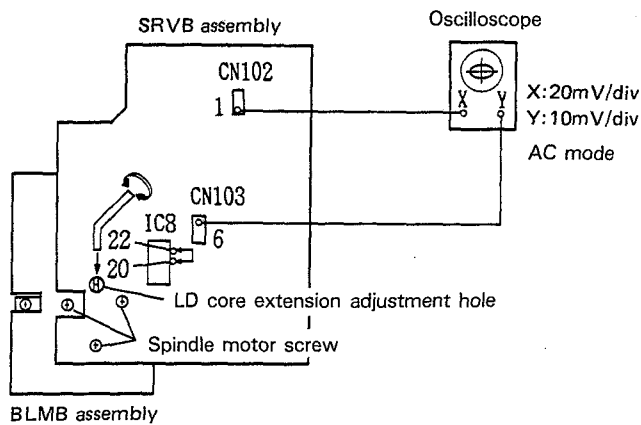

Connection diagram (2)

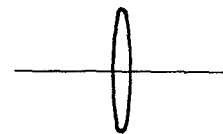

Fig. 1  
Lissajous Wave Form On Track  
Position Minimum X Direction

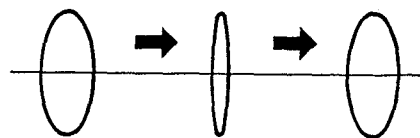

Fig. 2

**Adjustment Procedure**

1. Find Frame # 50,000 (outer edge) of the test disc.
2. Connect Pins 20 and 22 of IC8 (PM4001) on the SRVB assembly to open the TRKG servo loop.
3. During the adjustment avoid moving the Pick-up assembly by pressing the play key.
4. Observe the signal at CN102-1 (TRKG error) of the SRVB assembly. Adjust the grating with angular Screwdriver I so that the amplitude of this wave is as small as possible and the wave is smooth. (Connection Diagram 1 and Photo 1)
5. Put the oscilloscope in X-Y mode, connect the TRKG error signal from CN102-1 of the SRVB assembly as the X input and the TRKG SUM signal from CN103-6 of the SRVB assembly as the Y input, then observe the Lissajous wave form. Set the oscilloscope to 20mV/div for the X axis, 10mV/div for the Y axis, AC mode.
6. Adjust the grating to minimize the amplitude in the X direction of the Lissajous wave form. (Fig. 1)
7. Press the fast feed (◀◀) key to move the Pick-up assembly around the inner edge of the disc between Frames #1 and #500. Verify that this gives the maximum amplitude in the Y direction for the Lissajous wave form.
8. When the Lissajous wave is a bulging ellipse between Frame #1 and Frame #500, slightly loosen the spindle motor screw shown in connection diagram (2), then adjust the core extension for the LD spindle motor.
- 8-1 Insert Angular Screwdriver I in the hole for adjusting the LD motor axis centering.
- 8-2 Check the Lissajous wave form. Turn Angular Screwdriver I slowly to minimize the X direction of the Lissajous wave form, then turn Angular Screwdriver I to obtain the same Lissajous wave form as before. (Fig. 2)
9. Move the Pick-up assembly to near Frame #50,000, then adjust the grating to minimize the Lissajous wave in the X direction.
10. Move the Pick-up assembly back to the inner edge of the test disc between Frame #1-#500 and check that the X direction of the Lissajous wave form is minimal. If not, repeat the adjustments in Steps 8-10 at either the outer edge or the inner edge of the test disc.
11. Tighten the three screws for the LD spindle motor.



## 11.6 FINE GRATING ADJUSTMENT

### Mechanical Adjustments

- Objective: Finely adjust the grating so that the two TRKG servo beams shine on the best spot on the track on the disc
- Symptom if the adjustment is inadequate: Track skipping

- Measuring equipment and tools
- Measurement point
- Test disc and set
- Adjustment point

- Oscilloscope
- Angular Screwdriver I (GGV-129)
- SRVB assembly
- CN102-1 (TRKG error)
- CN103-6 (TRKG sum)
- TRKG servo open
- F series ..... #15,000
- NI ..... #16,000
- Grating

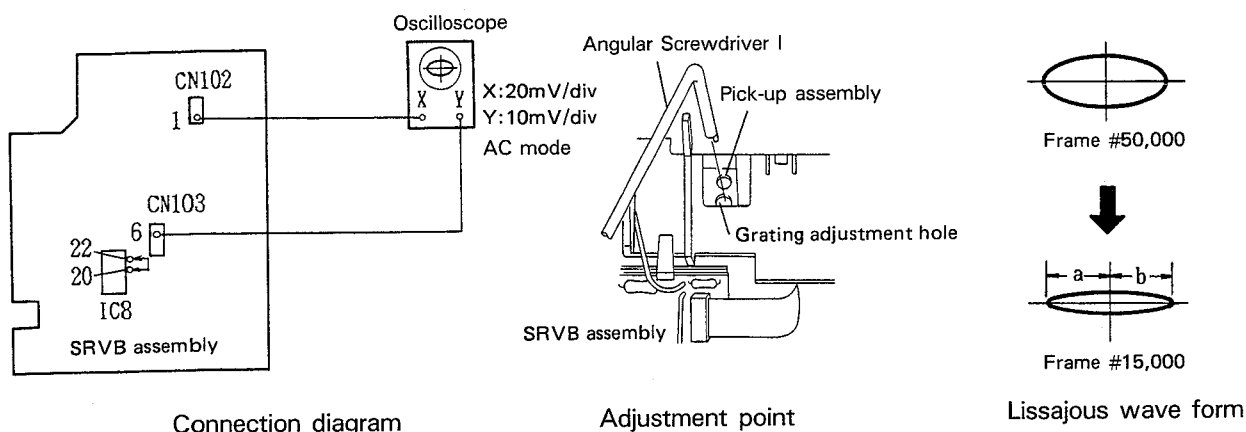

### Adjustment Procedure

Note: Angular Screwdriver I can not be inserted into the adjustment hole with the Pick-up assembly at Frame # 15,000 (#16,000), so adjust at Frame # 50,000, then double check the results at Frame # 15,000 (#16,000).

1. Press the fast feed (▶▶) key on the remote control to send the Pick-up assembly to around Frame # 50,000 on the outer edge, then press the play key.
2. Connect Pins 20 and 22 of IC8 (PM4001) on the SRVB assembly to open the tracking servo loop.
3. Put the oscilloscope in X-Y mode, connect the tracking error signal from CN102-1 of the SRVB assembly as the X input and the tracking SUM signal from CN103-6 of the SRVB assembly as the Y input, then observe the Lissajous wave form. Set the oscilloscope to 20 mV/division for the X axis, 10 mV/division for the Y axis, AC mode.
4. Insert Angular Screwdriver I into the grating adjustment hole. Turn Angular Screwdriver I in the direction of the front panel to the position with the smallest

amplitude of the Lissajous wave in the Y direction, then turn the screwdriver back slightly from that position. (Set the grating adjustment to just before the point at which the amplitude of the Lissajous wave in the Y direction is the smallest.)

5. Press the fast feed (◀◀) key to move the Pick-up assembly to Frame # 15,000 (#16,000), then check that the Y-direction amplitude of the Lissajous wave is minimum at that point. (If a and b, as shown in the figure above, are not equal, equalize them by adjusting VR4 (the variable resistor for adjusting the tracking balance)). If the Y amplitude is not minimum, send the Pick-up assembly back to Frame # 50,000 and finely adjust the grating again. Adjust the grating finely at Frame # 50,000 as many times as necessary to obtain the same minimum amplitude in the Y direction for the Lissajous wave at Frame # 50,000 and Frame # 15,000 (#16,000).
6. Remove the jumper connecting Pins 20 and 22 of IC8 (PM4001) on the SRVB assembly. Double check that the image on the TV screen is normal.

**11.7 CD SPINDLE MOTOR TILT ADJUSTMENT →**  
**CD Spindle Motor Axis Centering adjustment**

**Mechanical Adjustments**

- Objective: To adjust the tilt of the CD spindle motor to optimize the CD optic characteristics (e.g. the error rate)
- Symptom if the adjustment is inadequate: High error rate, track skipping

- Measuring equipment and tools
- Measurement point
- Test disc and set
- Adjustment point

- YEDS-7 CD test disc
- Angular Screwdriver II (GGV-063)
- SRVB assembly CN13-4 (RF signal)
- Play CD disc track # 23 (soundless portion)
- CD spindle motor

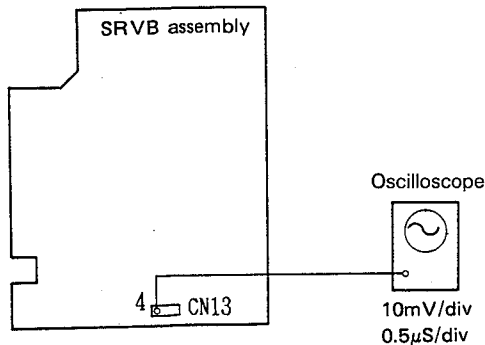

Connection diagram

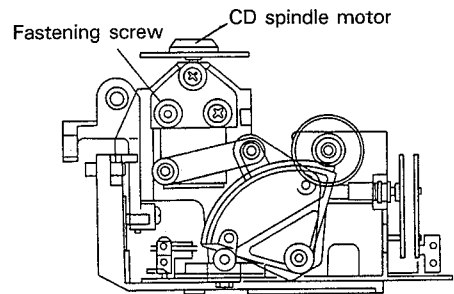

CD motor Mechanical assembly front diagram

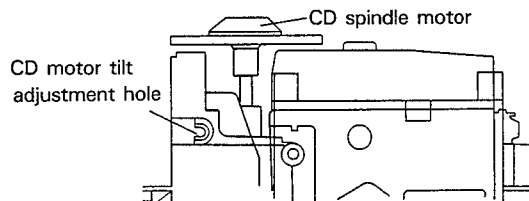

**Adjustment procedure**

1. With the disc player laying flat, mount a CD disc and raise the CD spindle motor.
2. Press the eject key on the front panel and remove the CD disc.
3. Push in the disc table.  
Loosen the fastening screw for the CD spindle motor slightly from the top of the player.
4. With the player laying flat, load the CD test disc (YEDS-7), then press the eject key on the Remote controller to stop the rotation of the spindle motor. With the player in this state, stand it up.
5. Play back the CD test disc and find Track #23.
6. Observe the RF signal at CN-13-4 of the SRVB assembly. Insert Angular Screwdriver II (GGF-063) into the hole for adjusting the CD motor tilt and adjust the tilt of the CD motor to maximize the amplitude of the RF signal.

### 11.8 CD SPINDLE MOTOR AXIS CENTERING ADJUSTMENT

### Mechanical Adjustments

- Objective: To adjust the position of the CD spindle motor.
- Symptom if the adjustment is inadequate: Track skipping

- Measuring equipment and tools
- Measurement point
- Test disc and set
- Adjustment point

- Oscilloscope
- YEDS-7 CD test disc
- Angular Screwdriver I (GGV-129)
- L.P.F.
- SRVB assembly
- CN102-1 (TRKG error)
- CN103-6 (tracking sum)
- TRKG servo open
- Play the CD test disc
- CD spindle motor

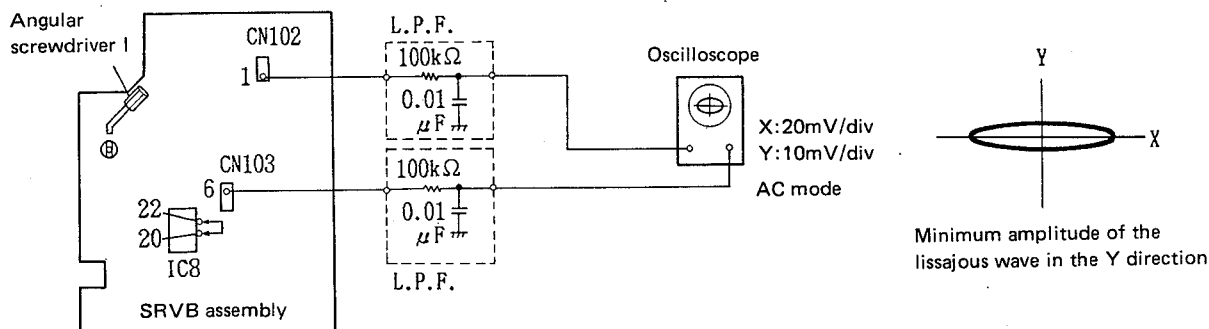

Connection diagram

#### Adjustment procedure

1. Put the oscilloscope in X-Y mode, connect the TRKG error signal from CN102-1 of the SRVB assembly as the X input and the TRKG sum signal from CN103-6 of the SRVB assembly as the Y input, then observe the Lissajous wave form. Set the oscilloscope to 20mV/div for the X axis, 10mV/div for the Y axis, AC mode.
2. Slightly loosen the two screws fastening the CD spindle motor pedestal.
3. Play back the CD test disc, moving the Pick-up assembly between Tracks #1-#5 at the inner edge. Connects Pins 20 and 22 of IC8 (PM4001) on the SRVB assembly to open the tracking servo loop.

4. Insert Angular Screwdriver I in the hole for adjusting the centering of the CD motor axis as shown in Figure above (left) Turn Angular Screwdriver I to the point that gives the maximum amplitude of the Lissajous wave in the Y direction.

Note: If the Lissajous wave is not clear, connect L.P.F.'s between the X and Y terminals of the oscilloscope and the measuring points as shown in the figure above.

5. Close the tracking servo loop, find Track #23, then open the tracking servo loop again. Double check that there is no significant change in the Lissajous wave.
6. Close the tracking servo loop.
7. Press the Eject key on the remote control once and lay the player flat. Press the Eject key again and remove the disc.
8. Tighten the screws securing the CD spindle motor.

**11.9 LD/CD DISC CLAMP SWITCHING POSITION ADJUSTMENT**

**Mechanical Adjustments**

- Objective: To adjust the position for the LD/CD clamp switch
- Symptom if the adjustment is inadequate: Disc not set

- |   |   |
|---|---|
| <ul style="list-style-type: none"> <li>• Measuring equipment and tools</li> <li>• Measurement point</li> <li>• Test disc and set</li> <li>• Adjustment point</li> </ul> | <ul style="list-style-type: none"> <li>• Screwdriver</li> <li>• LD (CD) disc clamp switch position adjustment slit</li> <li>• Start the LD (CD) disc. Start a pile of two LD discs.</li> <li>• LD (CD) disc clamp switch</li> </ul> |
|---|---|

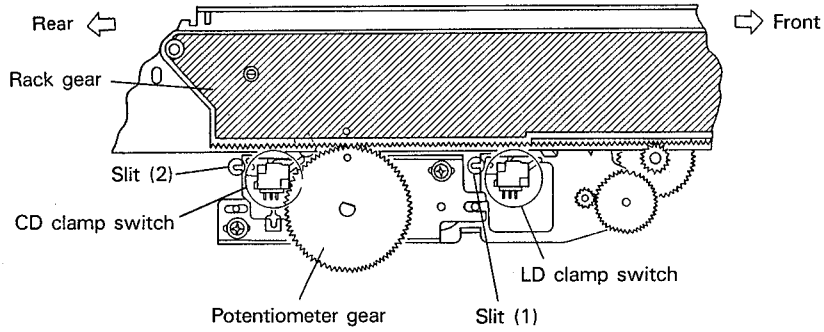

**Adjustment Procedure**

Note: If the disc table is ejected without the disc clamp switch being pressed even if there is a disc clamped, then carry out the following procedure to adjust the position for LD/CD disc clamp switching.

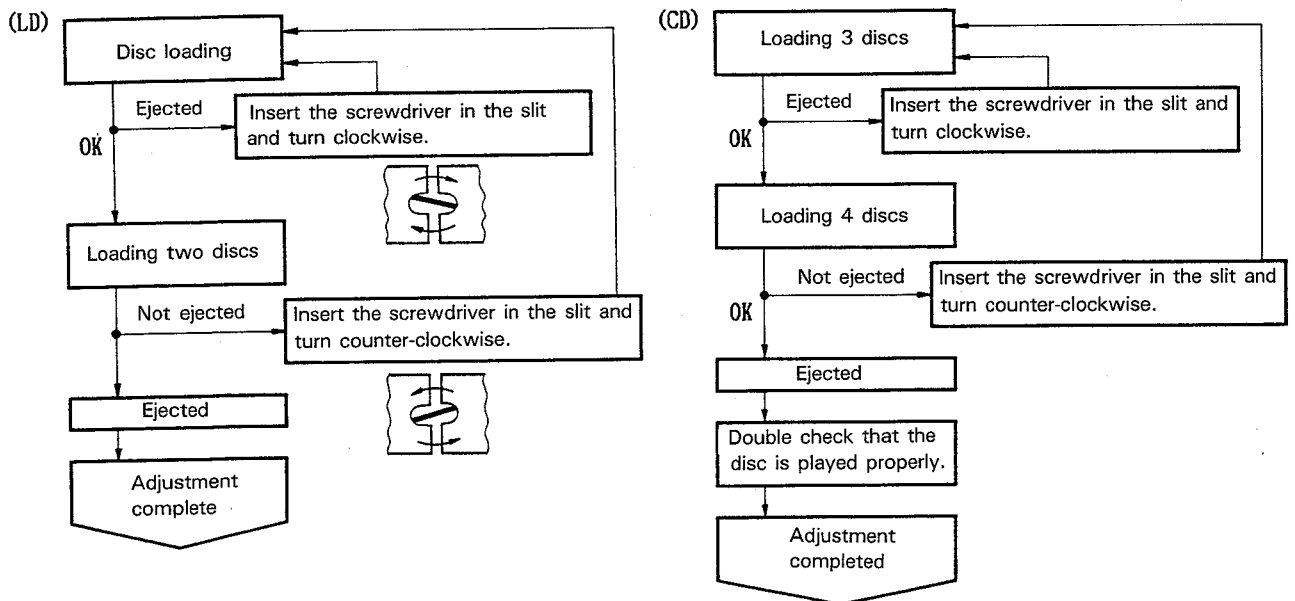

Flow chart

## 11.10 ROTARY ENCODER ADJUSTMENT

## Mechanical Adjustments

- Objective: To adjust the position of the rotary encoder
- Symptom if the adjustment is inadequate: Player can not distinguish LD discs from CD discs. Disc not set. Gear does not close completely for LD/CD swing.

- |   |  |
|---|--|
| <ul style="list-style-type: none"> <li>● Measuring equipment and tools</li> <li>● Measurement point</li> <li>● Test disc and set</li> <li>● Adjustment point</li> </ul> | <ul style="list-style-type: none"> <li>● Oscilloscope</li> <li>● Screwdriver</li> <li>● DSDC assembly CN17-8</li> <li>● Power switch on</li> <li>● Rotary encoder</li> </ul> |
|---|--|

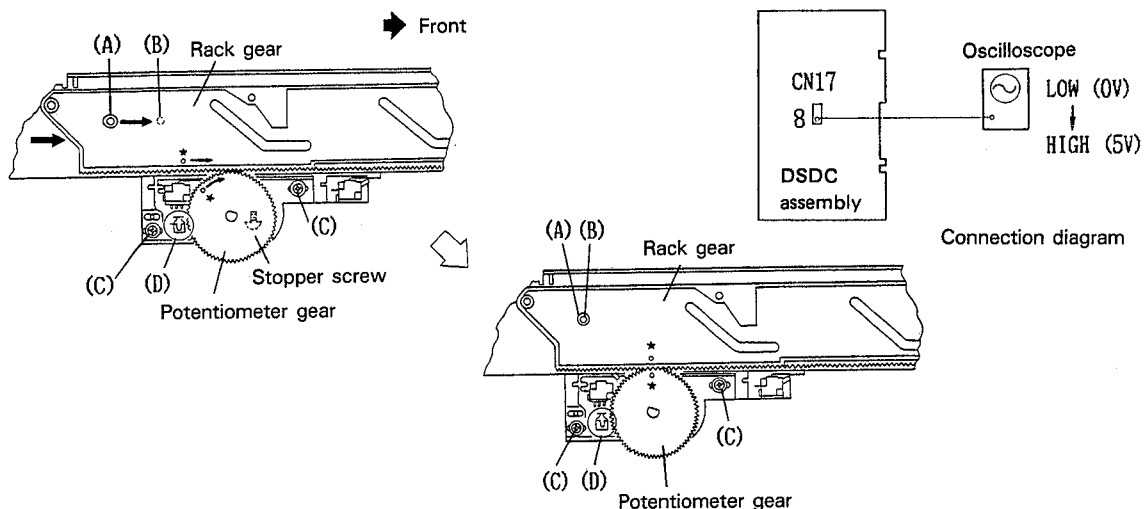
**Adjustment Procedure**

1. Switch on the disc player without mounting a disc.
2. Move the left and right rack gears slowly towards the Front panel simultaneously so that the clamber rises. Line up the Rack gear hole (A) with the subchassis hole (B).
3. Loosen the stopper screw shown in the figure so that the Potentiometer gear can move up and down. Then lightly lift up the Rack gear with your hand and adjust the meshing of the gears to line up the spot on the Rack gear marked with ★ with the hole in the potentiometer gear.
4. Loosen the two screws (C) and insert the screwdriver in the adjustment hole (D).
5. Finely adjust the position of the rotary encoder with the screwdriver so that the level at CN17-8 on the DSDC assembly goes from low (0V) to high (5V).
6. Tighten the two screws (C).
7. Mount a CD (LD) disc and cut the power off while the swing mechanism is switching the Spindle motor.
8. Double check that the hole (A) on the Rack gear and the hole (B) on the subchassis are lined up with each other. If they are not, repeat Steps 2 through 8.
9. Tighten the stopper screw, making sure that the Rack gear and the Potentiometer gear do not stop meshing and that there is a little play in the gear teeth, then apply screw locking solution.

11.11 SYNCHRONIZATION BELT ADJUSTMENT

Mechanical Adjustments

- Objective: To adjust the slack in the synchronization belt.
- Symptom if the adjustment is inadequate: Slipping in the synchronization gears

- Measuring equipment and tools
- Measurement point
- Test disc and set
- Adjustment point

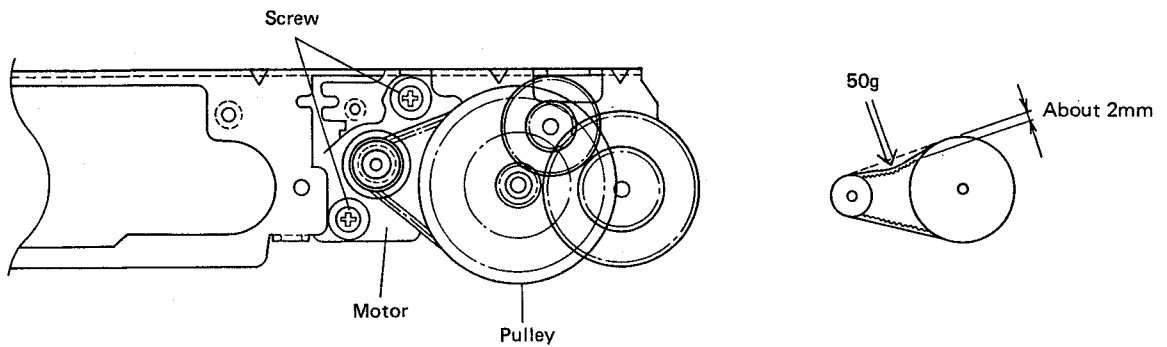

**Adjustment Procedure**

1. Apply approximately 50g of tension at the center of the pulley and move the motor so that the slack in the belt is about 2mm. Then tighten the screw temporarily.
2. Tighten the screw. Stop the pulley by hand when the motor is turning and be sure that the gears do not slip.

11.12 RIGHT ROLLER PLATE ASSEMBLY ADJUSTMENT

Mechanical Adjustments

- Objective: To have the gear (E), pinion (E) and the Intermediate rack mesh
- Symptom if the adjustment is inadequate: Abnormality in the loading operation

- Measuring equipment and tools
- Measurement point
- Test disc and set
- Adjustment point

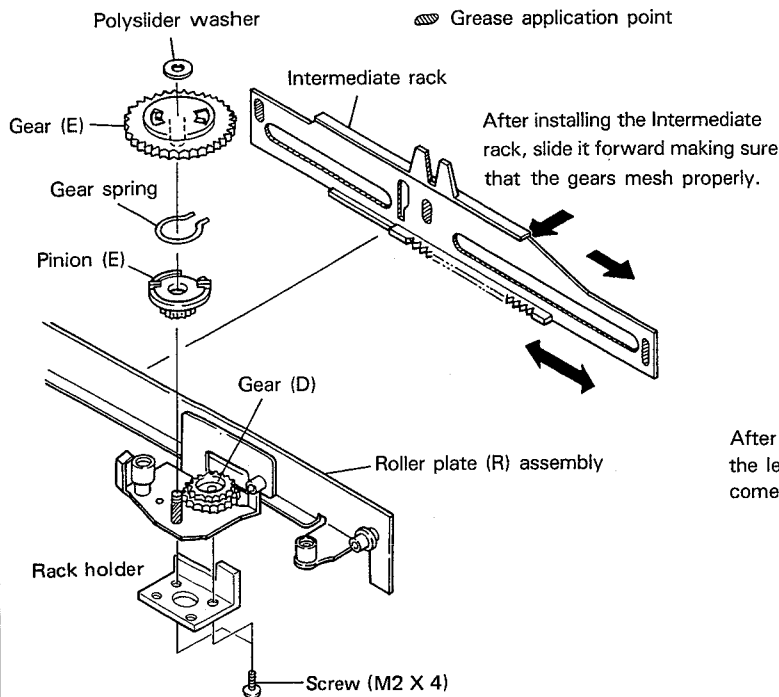

Fig. 1 Gear Assembly Gear Teeth Meshing

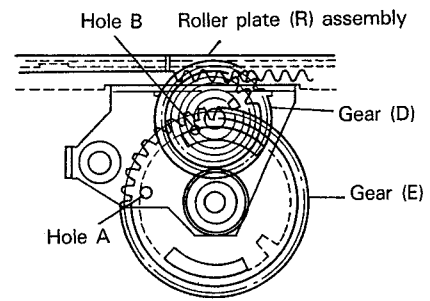

Fig. 2

After assembly, move the Intermediate rack all the way to the left and make sure that the position of the Gear hole (E) comes to the position shown below.

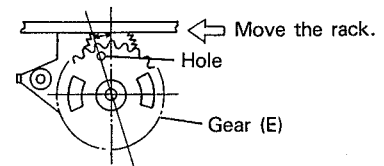

Fig. 3 Verifying the Gear Meshing

**Adjustment Procedure**

- Meshing the Roller plate (R) assembly, Gear (E), Pinion (E), and Intermediate rack
1. Line up the hole in the Gear (D) with Hole B and the hole in the Gear (E) with Hole A and install them on the Roller plate (R) assembly as shown in Fig. 2.
  2. With the parts in the positions relative to each other shown in Figures 1 and 2, install the Intermediate rack on the Roller plate (R) assembly.
  3. Move the Intermediate rack all the way from the position it has been fitted into and make sure that the hole in the Gear (E) is in the position shown in Fig. 3. When carrying out Operations 1-4 above, grease the locations shown in Fig. 1.

4. After installing the Intermediate rack, tighten the screws so that the Rack holder attaches the Roller plate (R) assembly (Fig. 1).

11.13 MESHING THE SUBCARRIER ASSEMBLY, SLIDE PLATE, GEAR (C)

Mechanical Adjustments

- Objective: The way the Subcarrier assembly, Slide plate, and Gear (C) mesh
- Symptom if the adjustment is inadequate: Abnormal loading operations

- Measuring equipment and tools
- Measurement point
- Test disc and set
- Adjustment point

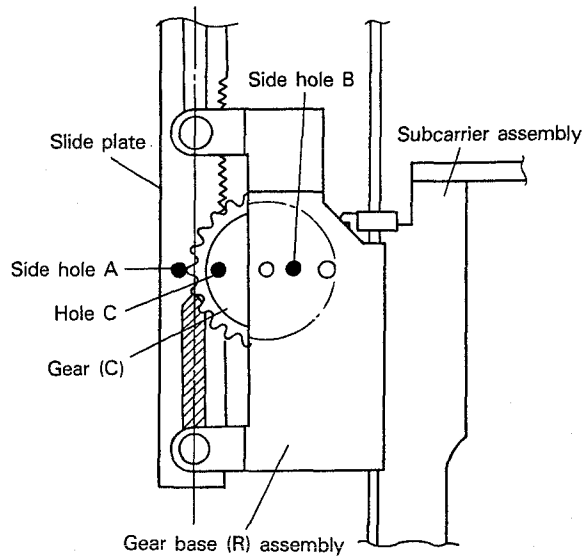

**Assembly**

1. Pull the Subcarrier assembly all the way towards you.
2. Push the Slide plate back to the point at which the Lock plate switches (turns in the carrier).
3. Install the Gear (C) so that Hole C on the Gear (C) is on the line connecting Side Hole A on the slide plate and Side Hole B on the Gear base (R) assembly, as shown in the figure.

**Verification**

1. Turn the Lock plate to the outside, release the lock for the Slide plate, slide it forward, then move the Sub-carriage assembly to the rear.
2. Move the Subcarriage all the way forward and make sure that the Lock plate for the Slide plate switches smoothly.
3. While performing these operations, make sure that the Carriage and Subcarriage assemblies are on the same center.



11.14 CARRIAGE INSERTION METHOD

Mechanical Adjustments

- Symptom if the adjustment is inadequate: Abnormal loading operations

- Measuring equipment and tools
- Measurement point
- Test disc and set
- Adjustment point

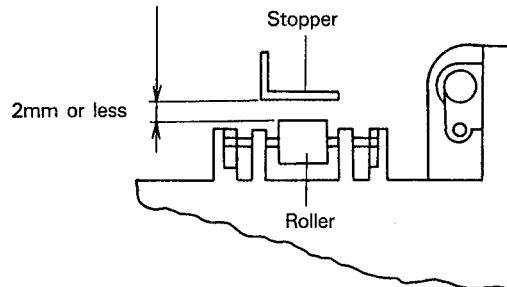

**Insertion Method**

1. Pull the Clamper holder forward until it locks. (The Loading mechanism comes farther forward than the out position.)
2. Set the Carrier horizontal and insert it keeping the left and right guide grooves lined up with the Rollers on the sides of the Loading mechanism.
3. Install the two Plastic rivets.
4. Install the Front panel.

**Verification**

1. Switch on the power, have the Carrier unload, mount a CD or LD disc, then check that the player can play this disc properly.
2. Next, mount the other type of Disc (LD or CD), switch off the power while the CD motor is swinging, then check that the clearance between the right rear section of the Carrier and the Stopper is at least 2 mm, as shown in the figure above.

## 12. ELECTRICAL ADJUSTMENT

### 12.1 SRVB ASSEMBLY ADJUSTMENT

#### 1. FOCS Offset Adjustment

#### SRVB Assembly Adjustment

- Objective: To set the electric offset for the FOCS servo to 0
- Symptom if the adjustment is inadequate: The FOCS is difficult to lock, causing the playability of the disc to deteriorate.

- Measuring equipment and tools
- Measurement point
- Test disc and set
- Adjustment point

- Oscilloscope
- SRVB assembly CN103-4 (FOCS error)
- Switch on the power without mounting the disc.
- SRVB assembly VR2

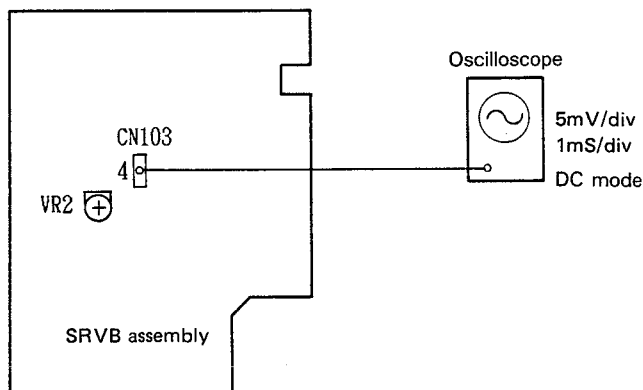

Connection Diagram

#### Adjustment Procedure

1. Switch on the power without mounting the disc.
2. Observe the DC voltage at CN103-4 (FOCS error) on the SRVB assembly and adjust VR2 so that this voltage is within 5mV of 0V.

2. TRKG Balance Adjustment

SRVB Assembly Adjustment

- Objective: To set the electric offset for the Tracking servo to 0
- Symptom if the adjustment is inadequate: Searches take longer (and jump operations become more difficult).

- Measuring equipment and tools
- Measurement point
- Test disc and set
- Adjustment point

- Oscilloscope
- SRVB assembly CN102-1 (TRKG error)
- LD test disc F series, N1 ... #20,000 still
- SRVB assembly VR4

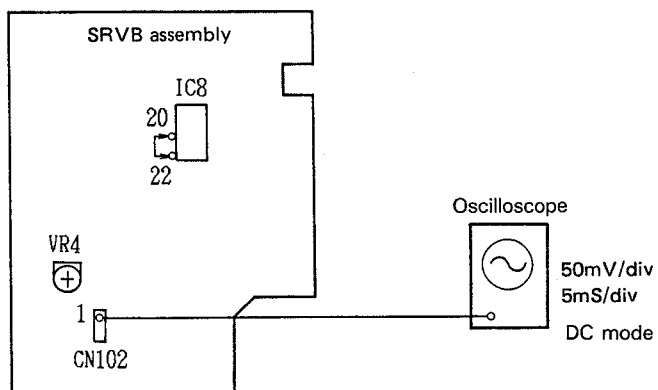

Connection Diagram

Adjustment Procedure

1. Mount the LD test disc. The player automatically begins to play this disc.
2. Find Frame #20,000 with the remote controller.
3. Connect Pins 20 and 22 of IC8 (PM4001) on the SRVB assembly to open the TRKG servo loop.
4. Observe the TRKG error signal at CN102-1 of the SRVB assembly.

5. Adjust VR4 so that positive amplitude and the negative amplitude of the TRKG error signal are the same.

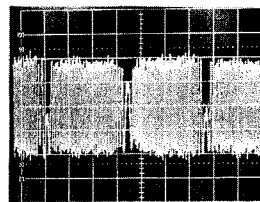
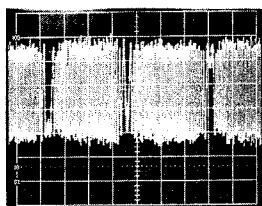

TRKG Error Wave Form

3. RF Level Adjustment

SRVB Assembly Adjustment

- Objective: To optimize the amplitude of the RF signals
- Symptom if the adjustment is inadequate: Too many drop outs

- |   |   |
|---|---|
| <ul style="list-style-type: none"> <li>• Measuring equipment and tools</li> <li>• Measurement point</li> <li>• Test disc and set</li> <li>• Adjustment point</li> </ul> | <ul style="list-style-type: none"> <li>• Oscilloscope</li> <li>• SRVB assembly CN13-4 (RF signal)</li> <li>• LD test disc F series ... # 15,000 still N1 ... # 16,000 still</li> <li>• SRVB assembly VR6</li> </ul> |
|---|---|

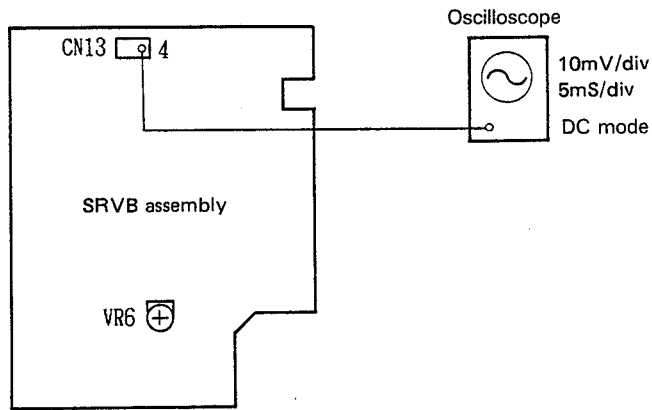

Connection Diagram

**Adjustment Procedure**

1. Find Frame # 15,000 (# 16,000).
2. Connect CN13-4 on the SRVB assembly and the oscilloscope and observe the RF signals.
3. Adjust VR6 so that the amplitude of the RF signals at CN13-4 is 300mVp-p.

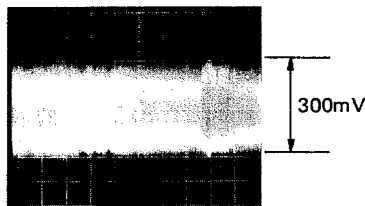

RF signal

4. TRKG Servo Loop Gain Adjustment

SRVB Assembly Adjustment

- Objective: To set the optimum loop gain for the TRKG servo
- Symptom if the adjustment is inadequate: Deterioration of the playability

- Measuring equipment and tools
- Measurement point
- Test disc and set
- Adjustment point

- Oscilloscope
- 68 kΩ resistor
- SRVB assembly CN102-1 ... Y CN102-2 ... X
- LD test disc F series ... #15,000 still N1 ... #16,000 still
- SRVB assembly VR5

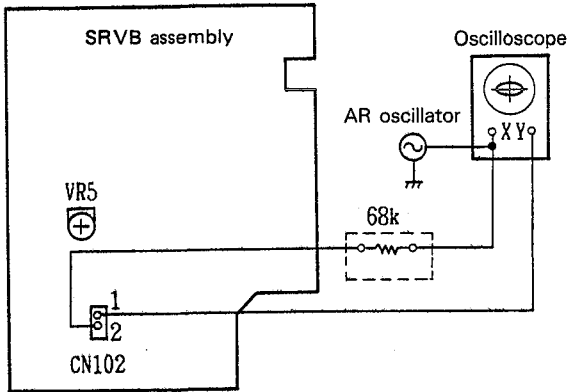

Test disc	F1	F2	F3	F4	F5
Frequency (kHz)	3.0	3.7	3.3	3.3	3.3
Output (Vp-p)	4.0	4.0	4.0	4.0	4.0

\*N1. . . . . 2.7kHz(4.0Vp-p)

Connection diagram

**Adjustment Procedure**

1. Set the output and the frequency for the AF oscillator to the values shown in the table above.
2. Find Frame #15,000 (#16,000).
3. Connect the resistor, AF oscillator, and oscilloscope as shown in the diagram above.
4. Put the oscilloscope in X-Y mode, then observe the Lissajous wave.

5. Adjust VR5 so that the Lissajous wave is symmetrical about both the X and Y axes.

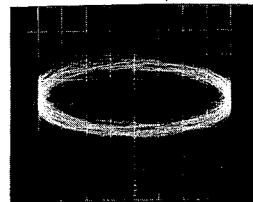
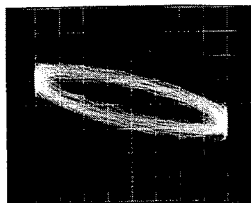

Making the Lissajous Wave Form Horizontal

5. FOCS Loop Gain Adjustment

SRVB Assembly Adjustment

- Objective: To set the optimum loop gain for the FOCS servo
- Symptom if the adjustment is inadequate: Deterioration of the playability

- Measuring equipment and tools
- Measurement point
- Test disc and set
- Adjustment point

- Oscilloscope
- 68 kΩ resistor
- AF oscillator
- SRVB assembly CN103-4 ... Y CN103-5 ... X
- Switch off the FOCS motor protection circuit.
- LD test disc F series ... #15,000 still N1 ... #16,000 still
- SRVB assembly VR3

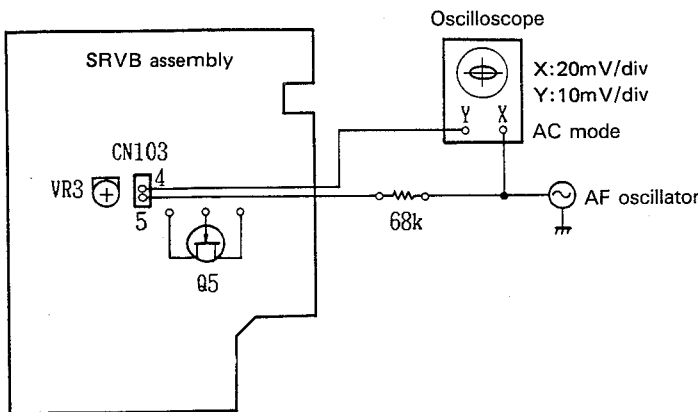

Test disc	F1	F2	F3	F4	F5
Frequency (kHz)	2.1	1.7	1.7	2.0	1.7
Output (Vp-p)	1.2	1.2	1.2	1.2	1.2

\*N1. . . . . 1.5kHz(1.2Vp-p)

Connection diagram

Adjustment Procedure

1. Connect the drain and the source of Q5 (2SK184) on the SRVB assembly to disable the FOCS motor protection circuit.
2. Set the output and the frequency for the AF oscillator to the values shown in the table above.
3. Find Frame # 15,000 (#16,000).
4. Connect the AF oscillator to CN103-5 and the oscilloscope to CN103-4, as shown in the diagram above.
5. Put the oscilloscope in X-Y mode, then observe the Lissajous wave.
6. Adjust VR3 so that the Lissajous wave is symmetrical about both the X and Y axes.
7. Remove the connection between the drain and the source of Q5.

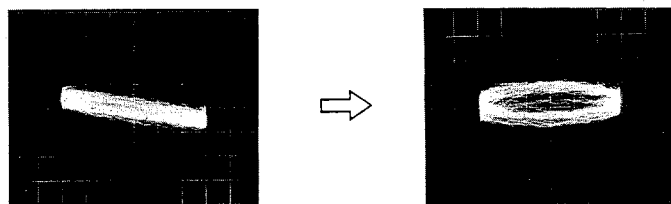

Making the Lissajous Wave Form Horizontal

6. FOCS Error Balance Adjustment

SRVB Assembly Adjustment

- Objective: To operate the FOCS servo at the optimum position
- Symptom if the adjustment is inadequate: Crosstalk

- Measuring equipment and tools
- Measurement point
- Test disc and set
- Adjustment point

- TV monitor
- Video output terminals on the player
- LD test disc F series ... #104 still N1 ... #115 still
- SRVB assembly VR1

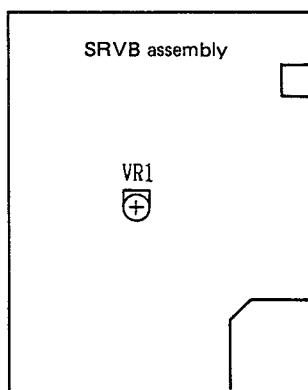

Connection diagram

**Adjustment Procedure**

1. Find Frame #104 (#115).
2. Adjust VR1 to minimize the crosstalk generated on the left and right sides of the TV screen.

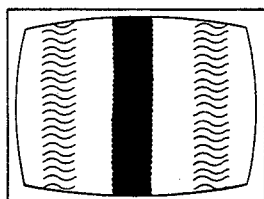

Screen with crosstalk

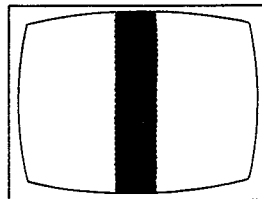

Minimum crosstalk

Screen

**7. CD FOCS Balance Adjustment**

**SRVB Assembly Adjustment**

- Objective: To operate the FOCS servo at the optimum position
- Symptom if the adjustment is inadequate: Higher error rate, breaks in the sound

- |   |  |
|---|--|
| <ul style="list-style-type: none"> <li>• Measuring equipment and tools</li> <li>• Measurement point</li> <li>• Test disc and set</li> <li>• Adjustment point</li> </ul> | <ul style="list-style-type: none"> <li>• Oscilloscope</li> <li>• CD test disc (YEDS-7)</li> <li>• SRVB assembly CN13-4</li> <li>• CD play</li> <li>• SRVB assembly VR12</li> </ul> |
|---|--|

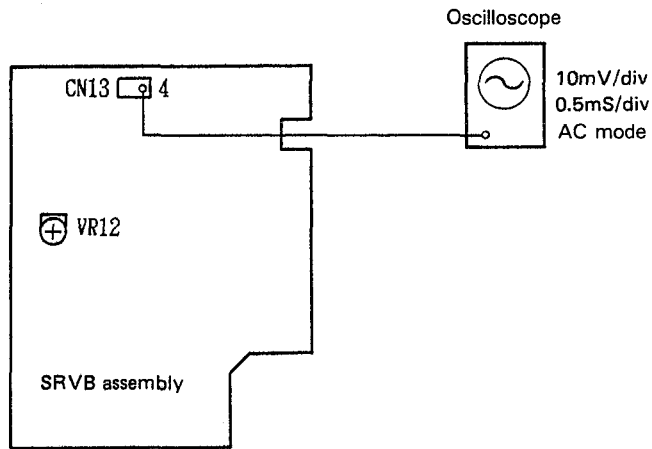

Connection diagram

**Adjustment Procedure**

1. Mount the CD test disc (YEDS-7) and play it.
2. Observe the RF signal at CN13-4 of the SRVB assembly.
3. Adjust VR12 to maximize the amplitude of the RF signal.



8. Inside/outside Position Detection Adjustment

SRVB Assembly Adjustment

- Objective: To determine the position for starting LD/CD play and the Pick-up position for when the Tilt servo is off
- Symptom if the adjustment is inadequate: The disc is not played and the CD motor can not swing.

- |   |   |
|---|---|
| <ul style="list-style-type: none"> <li>● Measuring equipment and tools</li> <li>● Measurement point</li> <li>● Test disc and set</li> <li>● Adjustment point</li> </ul> | <ul style="list-style-type: none"> <li>● TV monitor</li> <li>● CD test disc (YEDS-7)</li> <li>● LD test disc F series ... #1,500, #46,000, #17,000 N1 ... #1,500, #49,600, #18,300</li> <li>● CD test disc (YEDS-7) Track #1</li> <li>● SRVB assembly VR8, VR9, VR10, VR11</li> </ul> |
|---|---|

● How to Enter Test Mode

1. Mount the test disc.
2. Press the Eject (■/▲) key on the Remote control once to stop the rotation of the Spindle motor.
3. Switch off the power for the player.
4. With the front door of the player open, switch on its power.
5. Press the play key. After the image appears, press the display switch key on the remote control and make sure that either "P" or "L" is displayed on the top right of the screen.

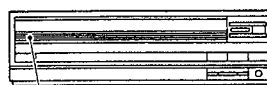

Front door

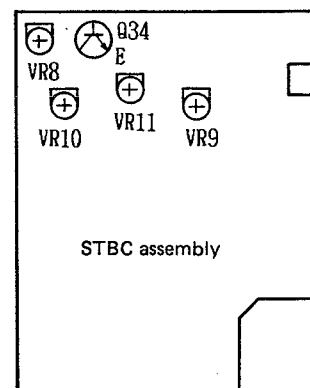
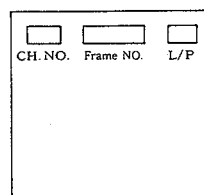

STBC assembly

Adjustment Procedure

1. LD inside position adjustment
  - Find Frame #1,500 (#1,500), then adjust VR8 so that the L/P display changes from L to P.
2. 12-inch LD outside position adjustment
  - Find Frame #46,000 (#49,600), then adjust VR9 so that the L/P display changes from P to L.
3. 8-inch LD outside position adjustment
  - Connect the emitter and the collector of Q34 (DTC124ES) of the SRVB assembly.
  - Find Frame #17,000 (#18,300), then adjust VR10 so that the L/P display changes from P to L.
  - Remove the connection between the emitter and the collector of Q34.
4. CD inside adjustment
  - Mount the CD test disc (YEDS-7).
  - Put the player in test mode again.
  - Press the Play key. After the image appears, press the Display switch key on the Remote control.
  - Press the Pause key on the Remote control, then find 1:00 on Track 1.
  - Adjust VR11 so that the L/P display changes from L to P.

12.2 STBC ASSEMBLY ADJUSTMENT

1. TBC Offset Adjustment

STBC Assembly Adjustment

- Objective: To set the offset voltage at Pin 1 of IC3 (BA4558DX) of the STBC assembly to 0V
- Symptom if the adjustment is inadequate: After a search, the color lock is slow.

- |   |  |
|---|--|
| <ul style="list-style-type: none"> <li>● Measuring equipment and tools</li> <li>● Measurement point</li> <li>● Test disc and set</li> <li>● Adjustment point</li> </ul> | <ul style="list-style-type: none"> <li>● Oscilloscope</li> <li>● L.P.F.</li> <li>● STBC assembly</li> <li>● IC3 (BA4558DX) Pin 1</li> <li>● Stand by</li> <li>● STBC assembly VR1</li> </ul> |
|---|--|

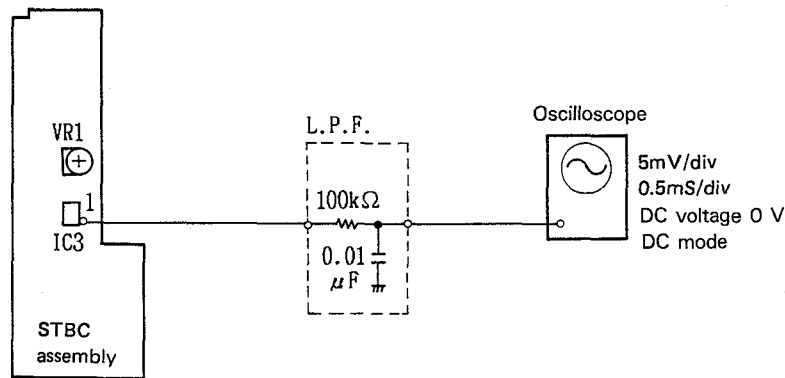

Connection diagram

**Adjustment Procedure**

1. Press the Eject key on the Remote control once to stop the rotation of the Spindle motor.
2. With the player on stand by, connect the oscilloscope to Pin 1 of IC3 (BA4558DX) and measure the offset voltage.
3. Adjust VR1 so that the offset voltage at Pin 1 of IC3 (BA4558DX) is 0 V.

Note: If the DC voltage can not be checked because of noise, connect the Low-pass filter (L.P.F.) as shown in the diagram above.

2. Time Axis Error Detection Adjustment

STBC Assembly Adjustment

- Objective: To balance the positive amplitude and negative amplitude of the Time axis error signal
- Symptom if the adjustment is inadequate: The screen is warped and the color lock does not work.

- |   |  |
|---|--|
| <ul style="list-style-type: none"> <li>• Measuring equipment and tools</li> <li>• Measurement point</li> <li>• Test disc and set</li> <li>• Adjustment point</li> </ul> | <ul style="list-style-type: none"> <li>• Oscilloscope</li> <li>• STBC assembly</li> <li>• LD disc play</li> <li>• STBC assembly VR2</li> </ul> |
|---|--|

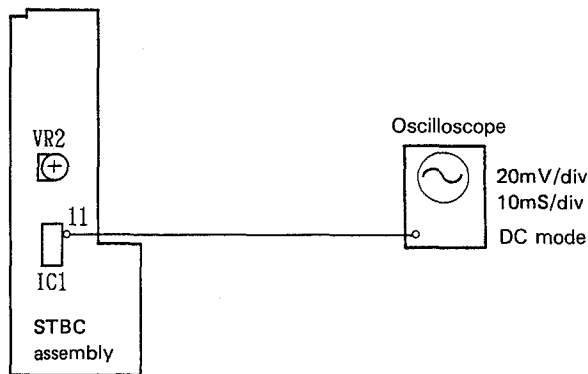

Connection diagram

**Adjustment Procedure**

1. Press the Play key.
2. Connect Pin 9 of IC601 (PA0017) of the VDEM assembly to ground to give the Time axis error compensation circuit a free run.
3. Connect the oscilloscope to Pin 11 of IC1 (PA5009) on the STBC assembly and observe the Time axis error signal.
4. Adjust VR2 so that the positive amplitude and the negative amplitude of the Time axis error signal (sine wave) are the same.

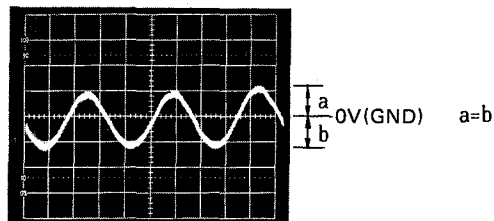

Time axis error

3. Sync Gate Timing Adjustment

STBC Assembly Adjustment

- Objective: To optimize the timing for the sync gate
- Symptom if the adjustment is inadequate: The colors are uneven, the color lock does not work, and the system starts from the middle without reading data.

- |   |   |
|---|---|
| <ul style="list-style-type: none"> <li>● Measuring equipment and tools</li> <li>● Measurement point</li> <li>● Test disc and set</li> <li>● Adjustment point</li> </ul> | <ul style="list-style-type: none"> <li>● Oscilloscope</li> <li>● STBC assembly</li> <li>● LD disc play</li> <li>● STBC assembly VR3</li> <li>● Q307 (emitter)</li> <li>● IC1 (PA5009) Pin 15</li> </ul> |
|---|---|

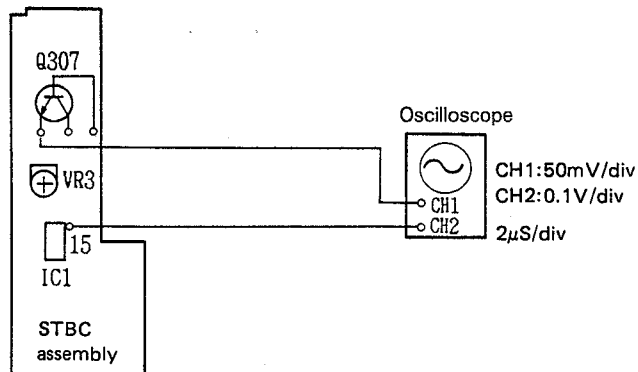

Connection diagram

**Adjustment Procedure**

1. Connect the emitter of Q307 on the STBC assembly to CH1 of the oscilloscope and Pin 15 of IC1 (PA5009) to CH2 of the oscilloscope and observe the Video signal and the Monostable multi-vibrator (MMV) output of the sync gate.
2. Adjust VR3 of the STBC assembly so that the falling edge of the MMV output is 5µsec. ahead of the H sync of the Video signal.

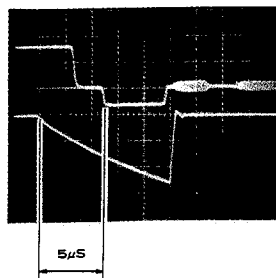

Top: Emitter of Q307  
50mV/div  
Bottom: Pin 15 of IC1  
0.1V/div  
2µS/div

Wave forms

4. Burst Gate Timing Adjustment

STBC Assembly Adjustment

- Objective: To optimize the timing for the burst gate
- Symptom if the adjustment is inadequate: The system starts from the middle. There is no color. The color is uneven. Fine stripes stand out.

- |   |   |
|---|---|
| <ul style="list-style-type: none"> <li>● Measuring equipment and tools</li> <li>● Measurement point</li> <li>● Test disc and set</li> <li>● Adjustment point</li> </ul> | <ul style="list-style-type: none"> <li>● Oscilloscope</li> <li>● STBC assembly</li> <li>● LD disc play</li> <li>● STBC assembly VR4</li> <li>● Q307 (emitter)</li> <li>● IC1 (PA5009) Pin 22</li> </ul> |
|---|---|

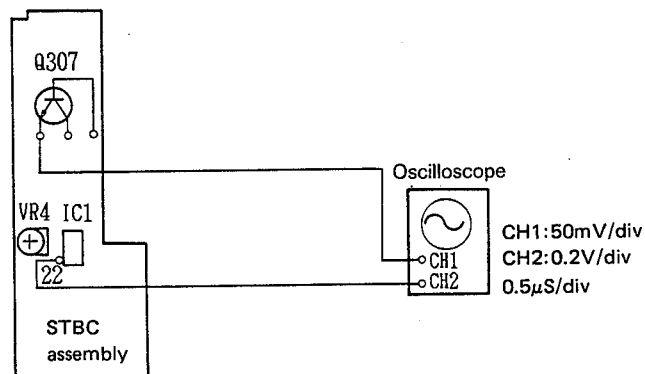

Connection diagram

**Adjustment Procedure**

1. Connect the emitter of Q307 on the STBC assembly to CH1 of the oscilloscope and Pin 22 of IC1 (PA5009) to CH2 of the oscilloscope and observe the Video signal and the Monostable multi-vibrator (MMV) output of the sync gate.
2. Adjust VR4 of the STBC assembly so that the falling edge of the MMV output is 1 µsec. later than the Burst signal of the Video signal.

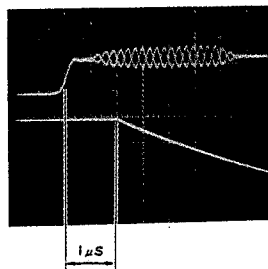

Top: Emitter of Q307  
50mV/div  
Bottom: Pin22 of IC1  
0.2V/div  
0.5µS/div

Wave forms

5. MIX Chroma Level Adjustment

STBC Assembly Adjustment

- Objective: To optimize the chroma level in the color phase compensation section
- Symptom if the adjustment is inadequate: There is much unevenness in the colors on the screen.

- |   |   |
|---|---|
| <ul style="list-style-type: none"> <li>● Measuring equipment and tools</li> <li>● Measurement point</li> <li>● Test disc and set</li> <li>● Adjustment point</li> </ul> | <ul style="list-style-type: none"> <li>● Oscilloscope</li> <li>● LD test disc</li> <li>● STBC assembly</li> <li>● Q307 (emitter)</li> <li>LD test disc F series ... #26,101 (Chap #20) N1 ... #7,201 (Chap #15) still</li> <li>● STBC assembly VR301</li> </ul> |
|---|---|

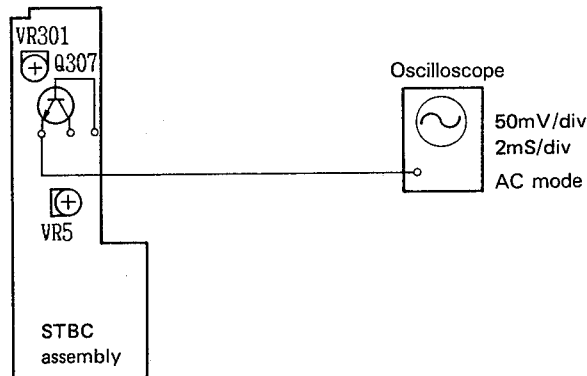

Connection diagram

**Adjustment Procedure**

1. Find Chapter #20 (#15) on the LD test disc.
2. Turn VR5 on the STBC assembly all the way counter-clockwise.
3. Connect the emitter of Q307 of the STBC assembly to the oscilloscope and observe the Video signal.
4. Adjust VR301 so that the waves in the chroma signal are smooth.

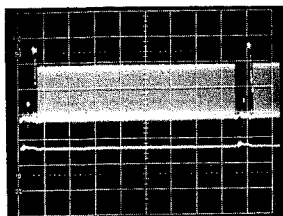

Optimum point

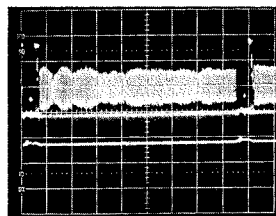

VR301 turned to the left of the optimum point

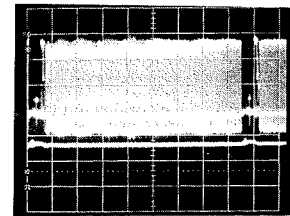

VR301 turned to the right of the optimum point

Wave forms

6. Color Phase Error Signal Level Adjustment

STBC Assembly Adjustment

- Objective: To optimize the level of the Error signal in the Color phase compensation section
- Symptom if the adjustment is inadequate: There is much unevenness in the colors on the screen.

- Measuring equipment and tools
- Measurement point
- Test disc and set
- Adjustment point

- TV monitor
- LD test disc
- Adjust while watching the TV monitor screen.
- LD test disc F series ... #26,101 (Chap #20) N1 ... #7,201 (Chap #15) still
- STBC assembly VR5

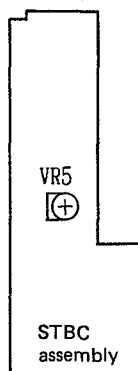

**Adjustment Procedure**

1. Find Chapter #20 (#15). (It shows a magenta screen.)
2. Adjust VR5 to the point at which the magenta image is most even.

### 12.3 VDEM ASSEMBLY ADJUSTMENT

#### 1.1 H Delay Video Level Adjustment

#### VDEM Assembly Adjustment

• Objective: To equalize the video levels for the 1H delay signal and the Main line video signal  
 • Symptom if the adjustment is inadequate: The 1H level is:
 

- Too high ... White drop out is noticeable and the horizontal adjustment is out of alignment (causing horizontal lines on the screen)
- Too low ... Black drop out is noticeable.

- |   |   |
|---|---|
| <ul style="list-style-type: none"> <li>• Measuring equipment and tools</li> <li>• Measurement point</li> <li>• Test disc and set</li> <li>• Adjustment point</li> </ul> | <ul style="list-style-type: none"> <li>• Dual trace oscilloscope</li> <li>• VDEM assembly</li> <li>• LD test disc F series ... # 19,801 (Chap # 15) N1 ... # 19,801 (Chap # 29) still</li> <li>• VDEM assembly VR501</li> </ul> |
|---|---|

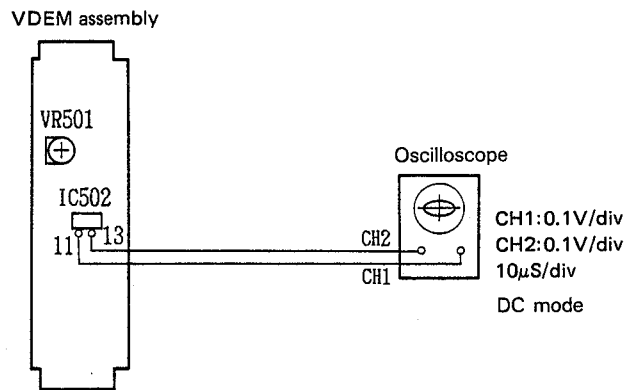

#### Adjustment Procedure

1. Connect Pin 13 of IC502 (PA3018) of the VDEM assembly to CH1 of the dual trace oscilloscope and Pin 11 to CH2.
  2. Find Chapter # 15 (# 29).
  3. Adjust VR501 so that the 1H delay video level (CH2) is the same as the main line video level (CH1).
- Note: The Video level is the level from the sync tip to the white peak.

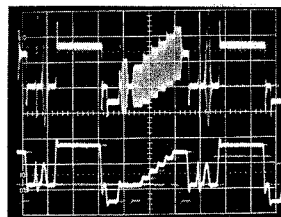

Main video signal

1H delay video signal

Wave forms



2. Output Video Level Adjustment

VDEM Assembly Adjustment

- Objective: To set the level of the Video signal to 2Vp-p
- Symptom if the adjustment is inadequate: The system starts up from the middle and cannot read the data. The screen is too bright or too dark.

- |   |  |
|---|--|
| <ul style="list-style-type: none"> <li>● Measuring equipment and tools</li> <li>● Measurement point</li> <li>● Test disc and set</li> <li>● Adjustment point</li> </ul> | <ul style="list-style-type: none"> <li>● Oscilloscope</li> <li>● STBC assembly</li> <li>● LD test disc F series ... # 19,801 (Chap # 15) N1 ... # 19,801 (Chap # 29) still</li> <li>● VDEM assembly VR602</li> </ul> |
|---|--|

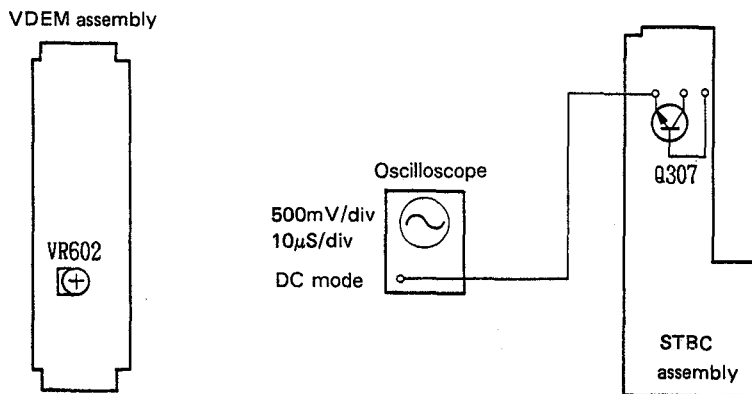

Connection diagram

**Adjustment Procedure**

1. Connect the emitter of Q307 of the STBC assembly to the Oscilloscope and measure the Video signal.
  2. Find Chapter # 15 (# 29).
  3. Adjust VR602 so that the Video level at the emitter of Q307 of the STBC assembly is 2Vp-p.
- Note: The Video level is the voltage from the sync tip to the white peak.

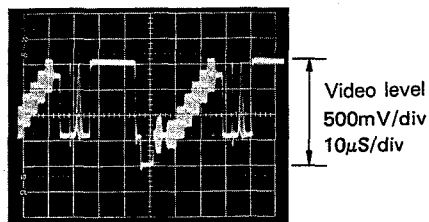

Wave forms

12.4 DSDC ASSEMBLY ADJUSTMENT

1. EFM Decoder PLL Offset Adjustment

DSDC Assembly Adjustment

- Objective: To optimize the offset for the PLL circuit used to extract the reference clock for the EFM decoder
- Symptom if the adjustment is inadequate: There is no digital sound or the sound is broken.

- |   |  |
|---|--|
| <ul style="list-style-type: none"> <li>• Measuring equipment and tools</li> <li>• Measurement point</li> <li>• Test disc and set</li> <li>• Adjustment point</li> </ul> | <ul style="list-style-type: none"> <li>• Voltmeter</li> <li>• DSDC assembly</li> <li>• Stand by</li> <li>• DSDC assembly VR303</li> <li>• IC306 (TL082CP) (NJM082D) Pin 1</li> <li>• Ground Pin 1 of IC301 (TC40H004P) of the DSDC assembly</li> </ul> |
|---|--|

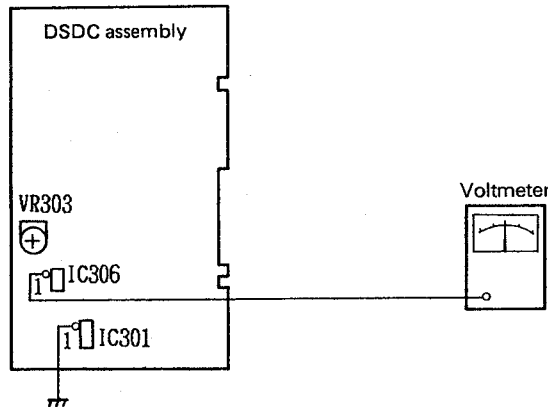

Connection diagram

**Adjustment Procedure**

1. Press the Eject key on the Remote control once to stop the rotation of the Spindle motor.
2. Connect the voltmeter to Pin 1 of IC306 (TL082CP) of the DSDC assembly and measure the PLL offset voltage.
3. Ground Pin 1 of IC301 (TC40H004P) of the DSDC assembly.
4. Adjust VR303 of the DSDC assembly so that the voltage at Pin 1 of IC306 is  $50 \pm 50\text{mV}$ .
5. Remove the line grounding Pin 1 of IC301.

2. VCO Free Run Frequency Adjustment

DSDC Assembly Adjustment

- Objective: To optimize the free run frequency for the reference clock for the EFM decoder
- Symptom if the adjustment is inadequate: There is no sound or the sound is broken.

- |   |   |
|---|---|
| <ul style="list-style-type: none"> <li>• Measuring equipment and tools</li> <li>• Measurement point</li> <li>• Test disc and set</li> <li>• Adjustment point</li> </ul> | <ul style="list-style-type: none"> <li>• Voltmeter</li> <li>• DSDC assembly</li> <li>• LDD test disc</li> <li>• DSDC assembly VL301</li> <li>• IC306 (TL082CP) (NJM082D) Pin 1</li> </ul> |
|---|---|

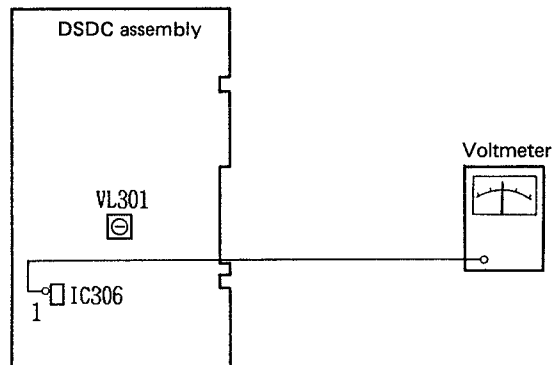

Connection diagram

**Adjustment Procedure**

1. Mount the LDD test disc. Play it.
2. Connect the voltmeter to Pin 1 of IC306 (TL082CP) of the DSDC assembly and measure the voltage of the VCO control signal.
3. Adjust VL301 of the DSDC assembly so that the voltage of the VCO control signal at Pin 1 of IC306 is  $150 \pm 100\text{mV}$ .

3. VCX0 Offset Adjustment

DSDC Assembly Adjustment

- Objective: To minimize the offset for the Spindle phase error comparator circuit
- Symptom if the adjustment is inadequate: The digital audio output is broken during LDD play back (there is synchronized noise).

- |   |   |
|---|---|
| <ul style="list-style-type: none"> <li>• Measuring equipment and tools</li> <li>• Measurement point</li> <li>• Test disc and set</li> <li>• Adjustment point</li> </ul> | <ul style="list-style-type: none"> <li>• Oscilloscope</li> <li>• LDD disc</li> <li>• DSDC assembly</li> <li>• IC305 (CXD1135Q) Pin 3 (leads of R336, R338, and R361)</li> <li>• LDD disc play</li> <li>• DSDC assembly VR301</li> </ul> |
|---|---|

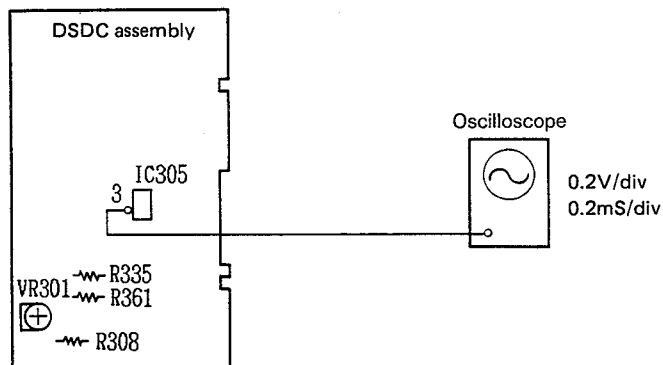

Connection diagram

**Adjustment Procedure**

1. Connect the oscilloscope to Pin 3 of IC305 (CXD1135Q) and measure the Spindle phase error output voltage.  
(If it is difficult to measure at Pin 3 of IC305, measure at the leads of one of the resistors connected to Pin 3, R336, R338, or R361.)
2. Mount the LDD test disc. Play it.

3. Adjust VR301 to the point at which the positive and the negative pulses are the smallest.

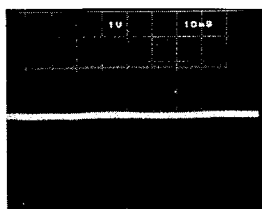

VR301 turned to the left of the adjustment point

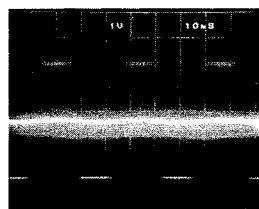

Adjustment point

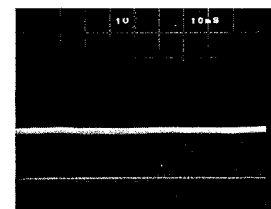

VR301 turned to the right of the adjustment point

Wave form

4. VCXO Free Run Frequency Adjustment

DSDC Assembly Adjustment

- Objective: To set the correct frequency for the crystal used for the EFM decoder

- |   |  |
|---|--|
| <ul style="list-style-type: none"> <li>• Measuring equipment and tools</li> <li>• Measurement point</li> <li>• Test disc and set</li> <li>• Adjustment point</li> </ul> | <ul style="list-style-type: none"> <li>• Frequency counter</li> <li>• DSDC assembly</li> <li>• IC402 (PCM56P-J) Pin 5</li> <li>• CD test disc play</li> <li>• DSDC assembly VR302</li> </ul> |
|---|--|

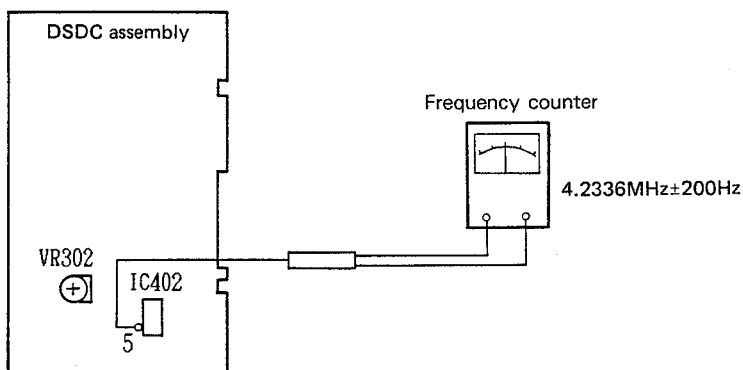

Connection diagram

**Adjustment Procedure**

1. Mount the CD test disc.
2. After the disc starts turning, press the Eject key on the Remote control once to stop the rotation of the Spindle motor.
3. Connect the frequency counter to Pin 5 of IC402 (PCM56P-J).
4. Adjust VR302 of the DSDC assembly so that the frequency is 4.2336MHz ± 200Hz.

**5. REF and Subcarriage Frequencies Adjustment**

**DSDC Assembly Adjustment**

- Objective: To set the reference and subcarriage frequencies to 3.579545 MHz  $\pm$  5 Hz
- Symptom if the adjustment is inadequate: No color lock

- |   |   |
|---|---|
| <ul style="list-style-type: none"> <li>• Measuring equipment and tools</li> <li>• Measurement point</li> <li>• Test disc and set</li> <li>• Adjustment point</li> </ul> | <ul style="list-style-type: none"> <li>• Frequency counter</li> <li>• STBC assembly • IC101 (PM2001) Pin 27</li> <li>• Power on</li> <li>• DSDC assembly VC101</li> </ul> |
|---|---|

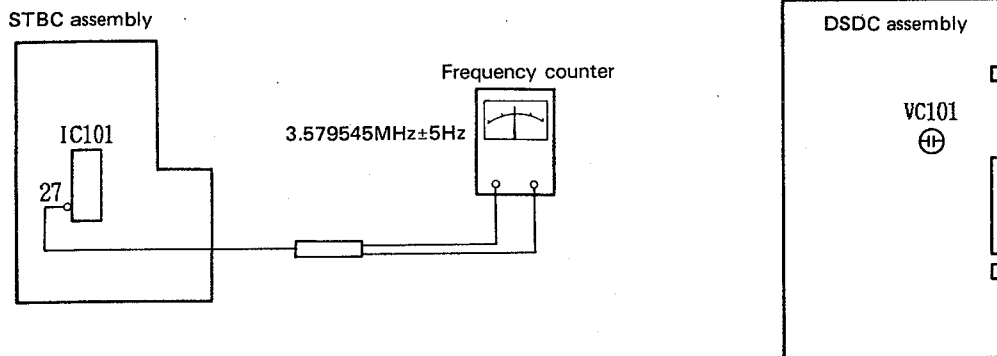

Connection diagram

**Adjustment Procedure**

1. Switch on the power.
2. Connect the frequency counter to Pin 27 of IC101 (PM2001) on the STBC assembly.
3. Adjust VC101 so that the frequency is 3.579545MHz  $\pm$  5Hz.

# 13. FOR S/G TYPE

## CONTRAST OF MISCELLANEOUS PARTS CLD-1010/S/G

The CLD-1010/S/G type is the same as the CLD-1010/KUC type with the exception of the following sections.

Mark	Symbol & Description	Part No.		Remarks
		CLD-1010/KUC	CLD-1010/S/G	
⚠	AC Power cord	VDG-038	VDG-039	
	Rubber foot	VEB1001	...	
	Cap	...	VEB-108	
	Packing case	VHG1011	VHG1012	
	Front panel assembly-S	VXX1041	VXX1044	
⚠ ★★	Line voltage selector (AC110V, 120V, 220V, 240V)	...	VSB-002	
	SW holder	...	VNE-675	
⚠ ★	F Type plug	...	VKX-017	
	Power transformer (T1) (AC120V)	VTT-078	...	
⚠ ★	Power transformer (T1) (AC110V, 120V, 220V, 240V)	...	VTT-079	
	CNNB assembly	...	Non supply	

## LSFB AND PWSB ASSEMBLY

### Circuit Diagrams

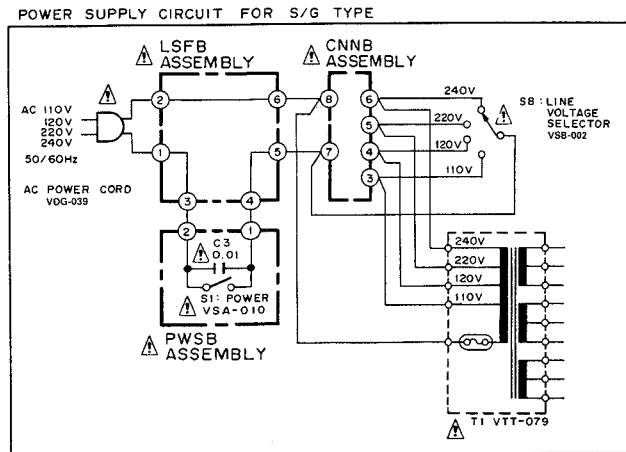

### P.C. Boards

