

ROTEL *hiFi*

RDA-980

DIGITAL SURROUND ADAPTER

Technical Manual

TABLE OF CONTENTS

Chassis Layout	1
Specifications	2
Functional Block Diagram.....	2
Wiring Diagram	3
IC Block Diagram.....	4
Reference Voltage.....	9
Schematic Diagram	11
Printed Circuit Boards	13
PC Board Ass'y Parts List.....	17

THE ROTEL CO.,LTD.

4F,BUNZAN-SHINSEN-BLDG 10-10, SHINSEN-CHO, SHIBUYAKU TOKYO JAPAN

ROTEL ELECTRONICS CO.,LTD.

3F-2, NO.35, FU HSING NORTH ROAD, TAIPEI, TAIWAN, REPUBLIC OF CHINA

MN20002346

Chassis Layout

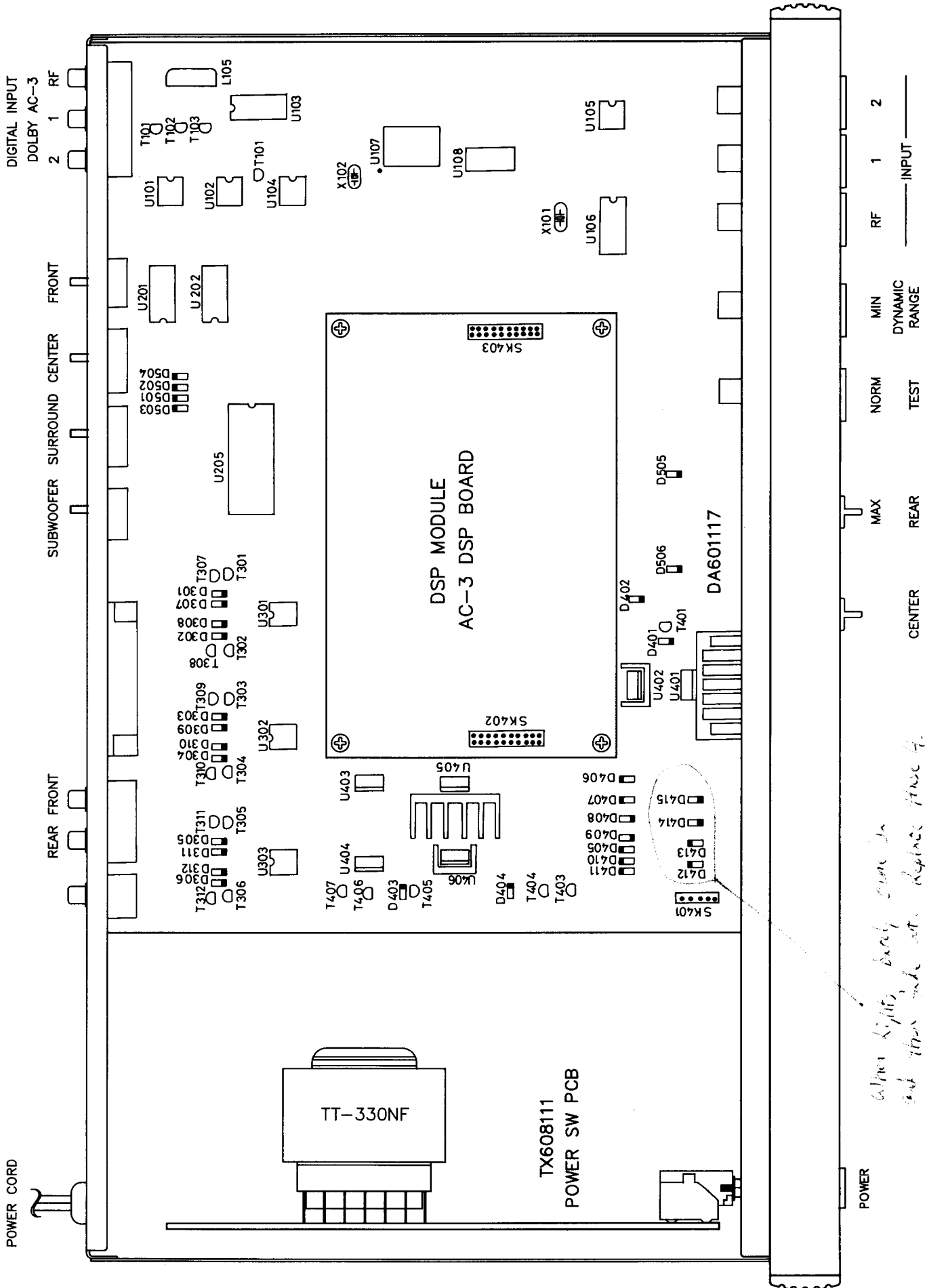

SPECIFICATIONS

AUDIO

Frequency Response	5-20,000 Hz, \pm 1.0 dB
Signal to Noise Ratio	90 dB, IHF A @ 1 kHz
Input Impedance	75 Ohm
Output Impedance	1 k Ohm
Total Harmonic Distortion	0.008 % (1 kHz)
Output	1.4 volts, large speaker @ 1 kHz, 0 dB FS
Power Consumption	25 watts

Power Requirements (AC)	115 volts 50/60 Hz <i>or</i>
	230 volts 50/60 Hz

Weight	4.6 Kg, 10.12 Lb.
Dimensions	440 x 73 x 270 mm (W x H x D)
	17.38 x 2.87 x 10.63" (W x H x D)

All specifications are accurate at the time of printing. Rotel reserves the right to make improvements without notice.

FUNCTIONAL BLOCK DIAGRAM

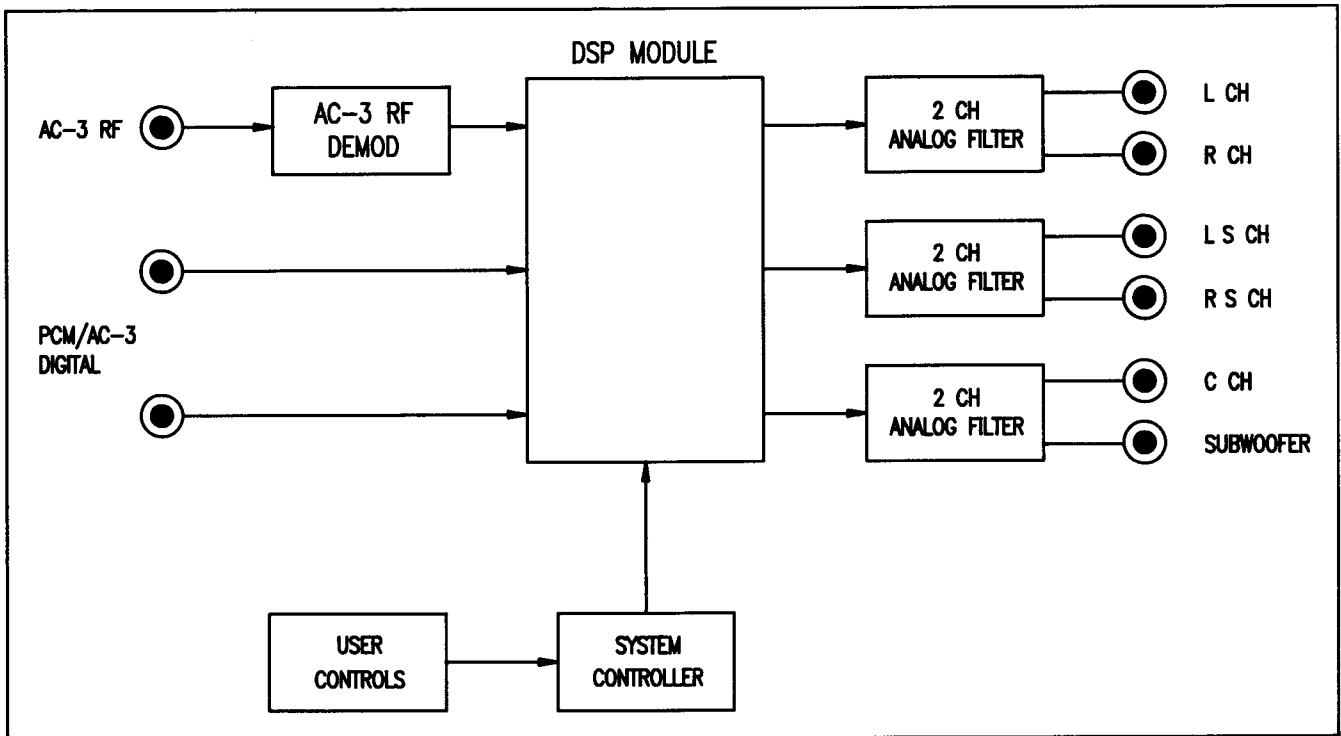

Wiring Diagram

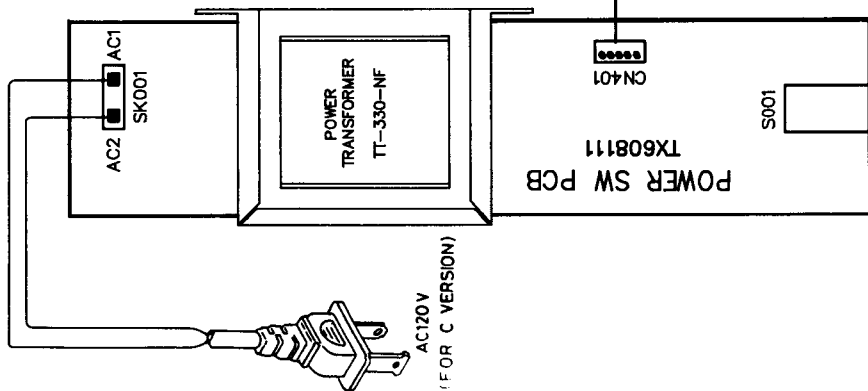
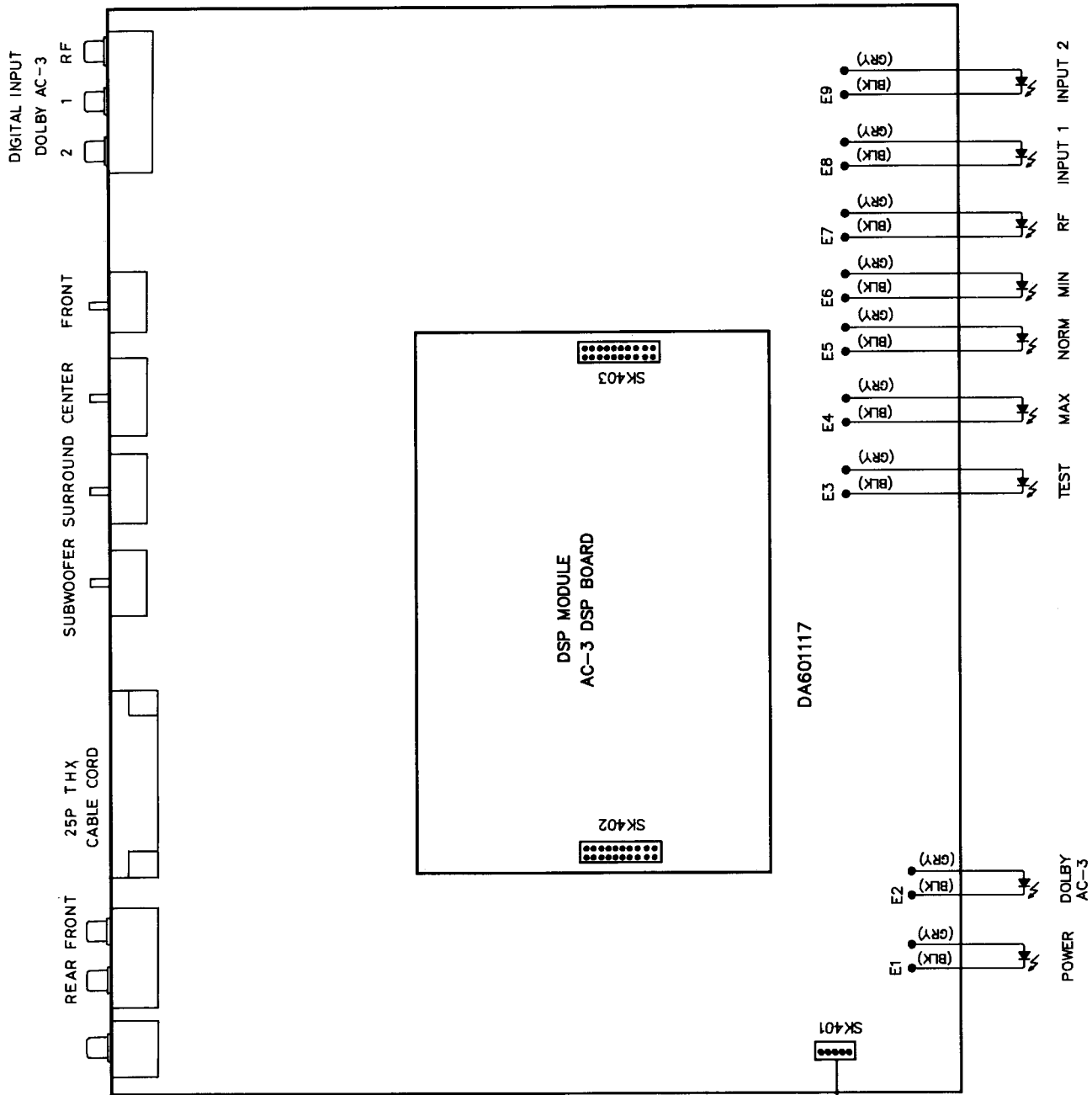

IC BLOCK DIAGRAM

TC74HC08AP BLOCK DIAGRAM

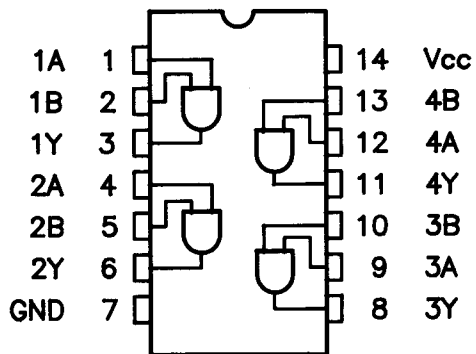

TC74HCU04AP BLOCK DIAGRAM

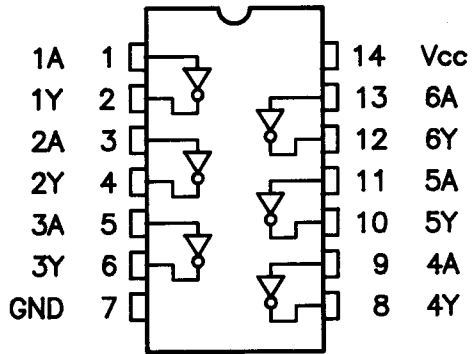

JNM7909FA / JNM7905FA BLOCK DIAGRAM

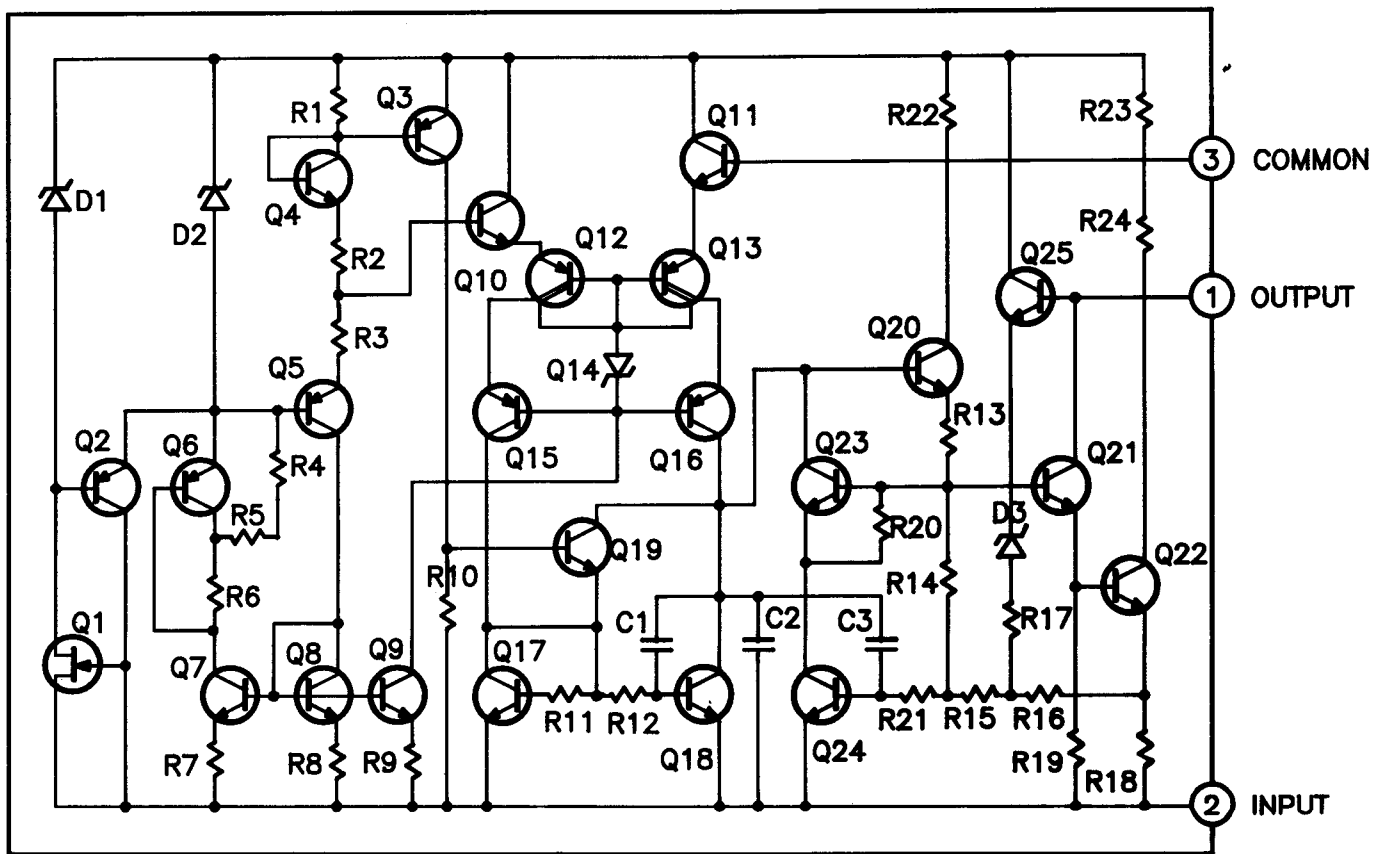

IC BLOCK DIAGRAM

NE5532AN BLOCK DIAGRAM

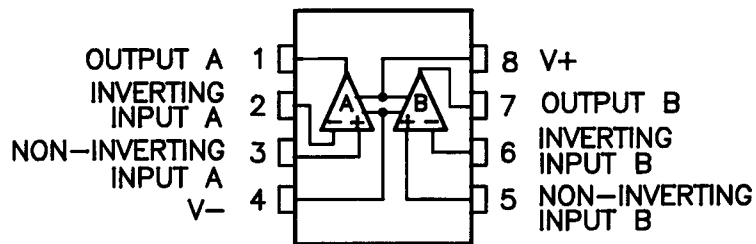

NJM4558DD BLOCK DIAGRAM

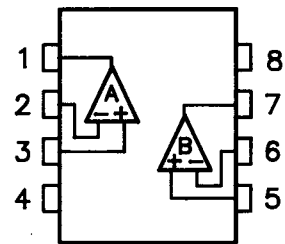

NJM7809FA / NJM7805FA BLOCK DIAGRAM

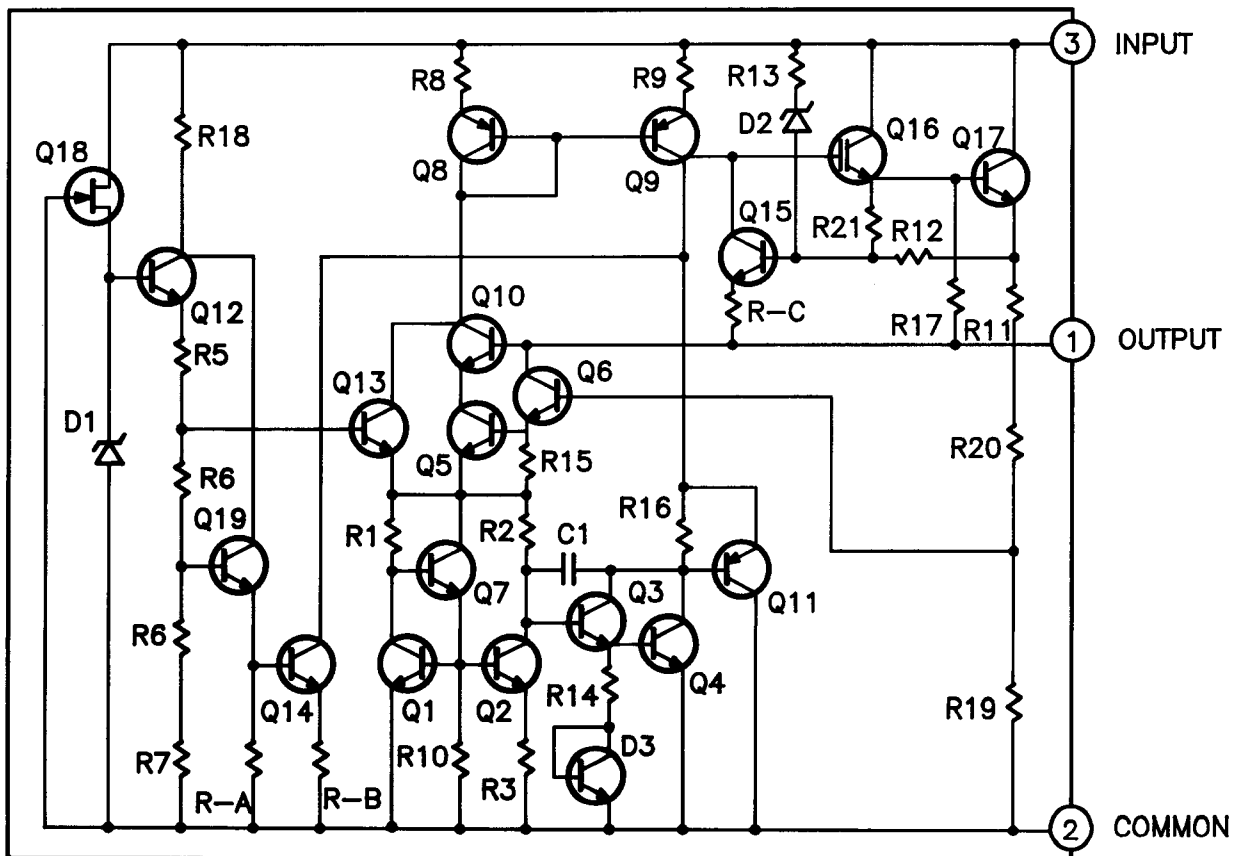

IC BLOCK DIAGRAM

TC74HC32AP BLOCK DIAGRAM

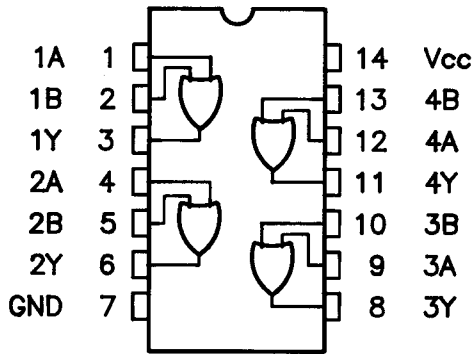

MC14577CP BLOCK DIAGRAM

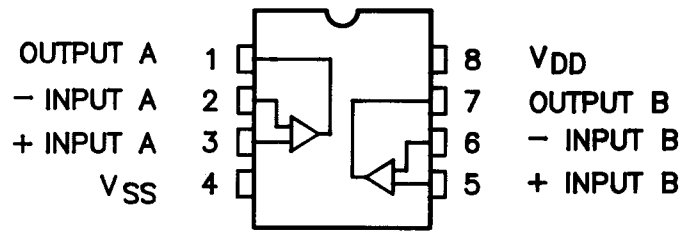

PIC16C57-XT/P BLOCK DIAGRAM

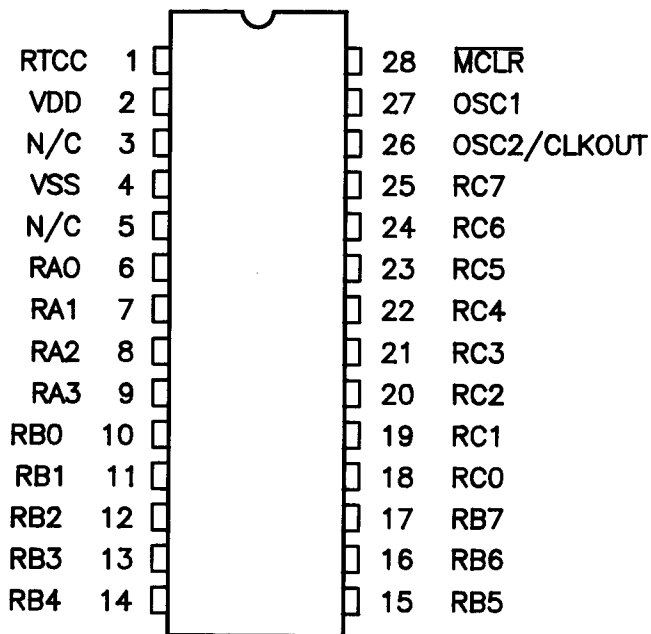

NAME	FUNCTION
RA0 - RA3	I/O PORT A
RB0 - RB7	I/O PORT B
RC0 - RC7	I/O PORT C
RTCC	REAL TIME CLOCK/COUNTER
MCLR	MASTER CLEAR
OSC1	OSCILLATOR (INPUT)
OSC2/CLKOUT	OSCILLATOR (OUTPUT)
VDD	POWER SUPPLY
VSS	GROUND
N/C	NO (INTERNAL) CONNECTION

IC BLOCK DIAGRAM

NJM360D BLOCK DIAGRAM

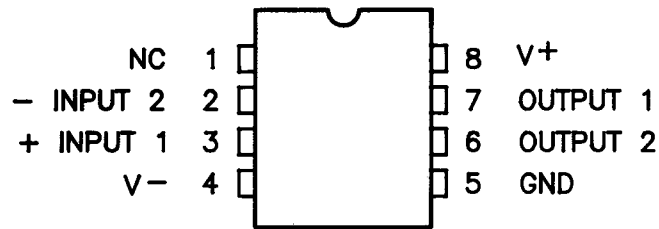

SRM20259LTM-10 BLOCK DIAGRAM

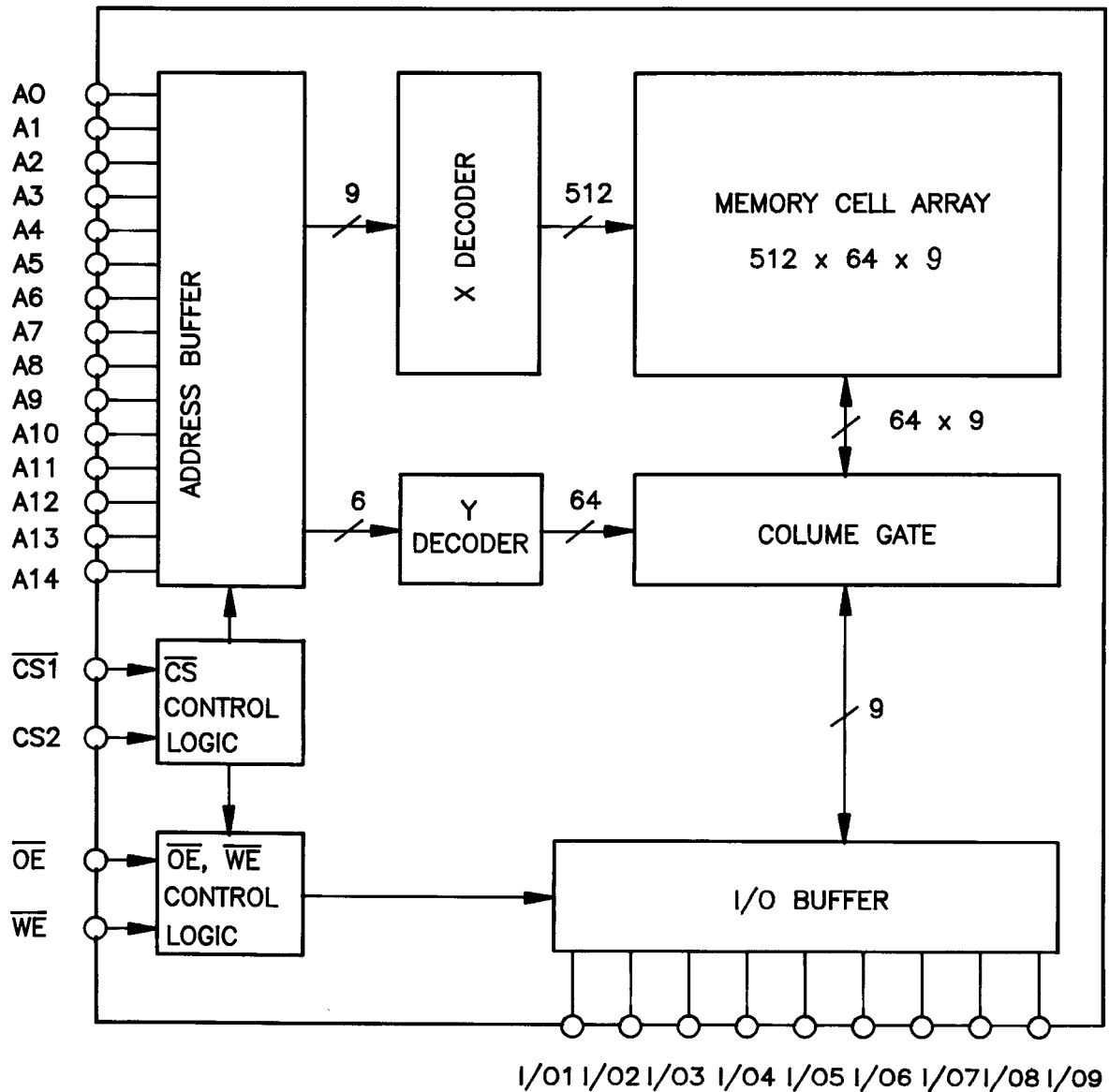

IC BLOCK DIAGRAM

PD4606A BLOCK DIAGRAM

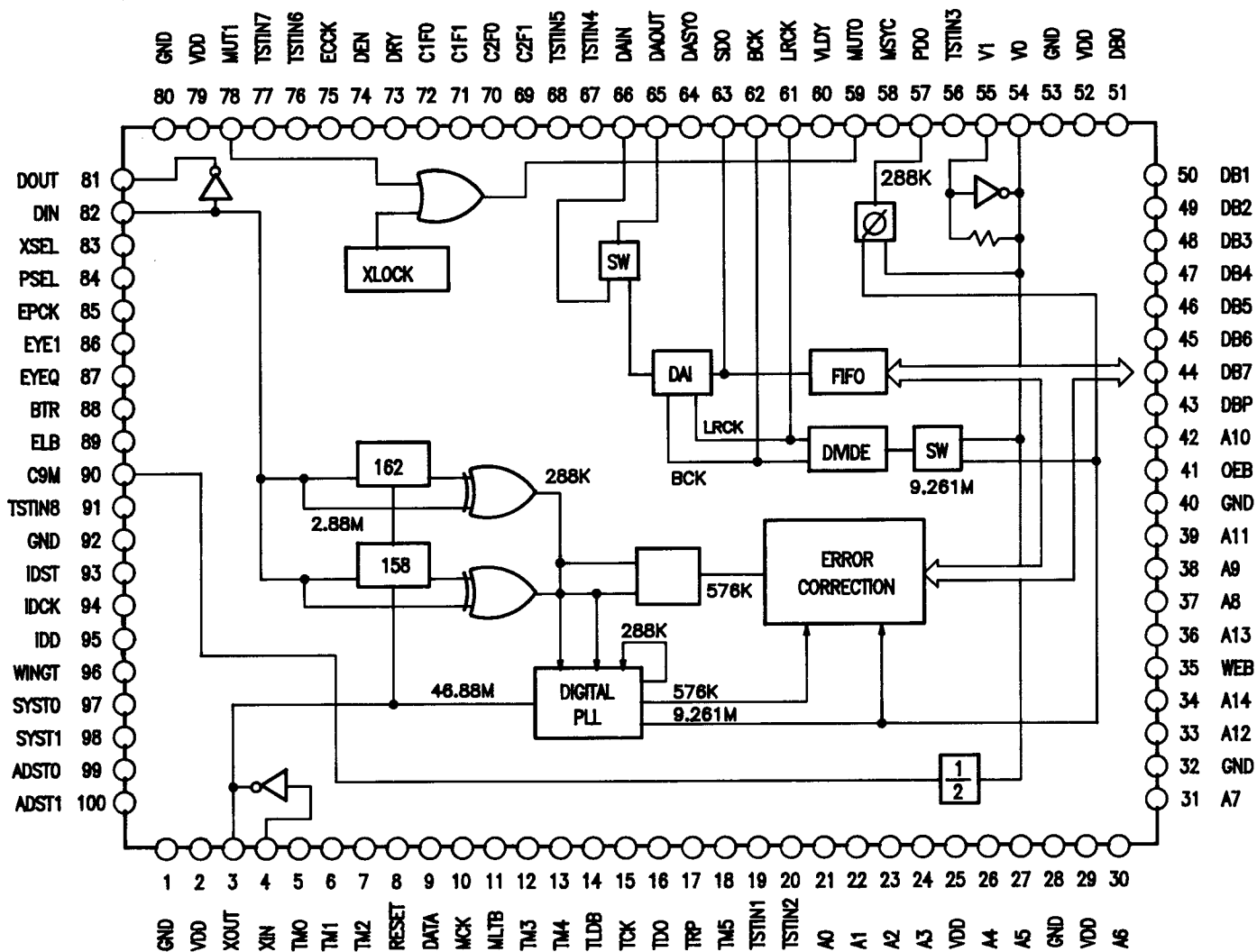

REFERENCE VOLTAGE

IC PIN NUMBER DC VOLTAGES									
SYMBOL NO.	DEVICE	1	2	3	4	5	6	7	8
U101	MC14577CP	0V	0V	0V	-4.8V	0V	0V	0V	4.9V

IC PIN NUMBER DC VOLTAGES									
SYMBOL NO.	DEVICE	1	2	3	4	5	6	7	8
U102	NJM360D	0V	0V	0V	-4.8V	0V	1.3V	1.9V	4.9V

IC PIN NUMBER DC VOLTAGES													
SYMBOL NO.	DEVICE	1	2	3	4	5	6	7	8	9	10	11	12
U103	TC74HCU04AP	1.8V	2.6V	2.6V	2.3V	2.3V	2.6V	0V	4.9V	0V	2.4V	2.4V	2.4V
		13	14										
		2.4V	5V										

IC PIN NUMBER DC VOLTAGES									
SYMBOL NO.	DEVICE	1	2	3	4	5	6	7	8
U104	NJM4558DD	-3.5V	2.4V	0V	-4.8V	2.2V	2.2V	0V	4.9V

IC PIN NUMBER DC VOLTAGES									
SYMBOL NO.	DEVICE	1	2	3	4	5	6	7	8
U105	NJM4558DD	-1.8V	2.5V	2.5V	-4.9V	0V	0V	1.8V	5V

IC PIN NUMBER DC VOLTAGES													
SYMBOL NO.	DEVICE	1	2	3	4	5	6	7	8	9	10	11	12
U106	TC74HCU04AP	2.3V	2.7V	2.2V	2.3V	0V	5.1V	0V	5.1V	0V	0V	5V	5.1V
		13	14										
		0V	5.1V										

IC PIN NUMBER DC VOLTAGES													
SYMBOL NO.	DEVICE	1	2	3	4	5	6	7	8	9	10	11	12
U107	PD4606A	0V	5V	2.7V	2.6V	0V	0V	0V	5.1V	5V	5V	5V	0V
		13	14	15	16	17	18	19	20	21	22	23	24
		0V	0V	0V	0V	0V	0V	5V	0V	0V	0V	5V	0V
		25	26	27	28	29	30	31	32	33	34	35	36
		0V	0V	1.2V	0V	5V	0V	1.2V	0V	1.2V	0V	5V	0V
		37	38	39	40	41	42	43	44	45	46	47	48
		1.2V	0V	1.2V	0V	5V	1.2V	5V	5V	5V	5V	5V	5V
		49	50	51	52	53	54	55	56	57	58	59	60
		5V	5V	5V	5V	0V	2.5V	2.6V	0V	4.1V	0V	5V	0V
		61	62	63	64	65	66	67	68	69	70	71	72
		2.5V	0V	0V	5V	2.5V	0V	0V	0V	0V	0V	0V	0V
		73	74	75	76	77	78	79	80	81	82	82	84
		0V	0V	2.5V	0V	0V	4.9V	5V	0V	2.3V	2.6V	4.9V	0V
		85	86	87	88	89	90	91	92	93	94	95	96
		2.5V	2.1V	4.3V	0.1V	2.6V	2.3V	0V	0V	0V	2.5V	3.4V	5V
		97	98	99	100								
		0V	0V	0V	0V								

IC PIN NUMBER DC VOLTAGES													
SYMBOL NO.	DEVICE	1	2	3	4	5	6	7	8	9	10	11	12
U108	SRM20259LTM-10	1.2V	0V	1.2V	0V	5V	5V	0V	5V	0V	0V	1.2V	1.2V
		13	14	15	16	17	18	19	20	21	22	23	24
		0V	0V	0V	0V	0.1V	0.1V	0.1V	5V	5V	5V	5V	0V
		25	26	27	28	29	30	31	32				
		5V	5V	5V	5V	5V	0V	1.2V	5V				

IC PIN NUMBER DC VOLTAGES													
SYMBOL NO.	DEVICE	1	2	3	4	5	6	7	8	9	10	11	12
U201	TC74HC32AP	0V	0V	0V	2.5V	0V	2.5V	0V	5V	2.4V	5V	5V	2.4V
		13	14										
		5V	5V										

REFERENCE VOLTAGE

IC PIN NUMBER DC VOLTAGES													
SYMBOL NO.	DEVICE	1	2	3	4	5	6	7	8	9	10	11	12
U202	TC74HC08AP	2.5V	5V	2.5V	5V	5V	5V	0V	0V	0V	0V	0V	0V
		13	14										
		0V	5V										

IC PIN NUMBER DC VOLTAGES													
SYMBOL NO.	DEVICE	1	2	3	4	5	6	7	8	9	10	11	12
U205	PIC16C57-XT/P	0V	5V	0V	0V	0V	4.5V	4.3V	0V	4.4V	0V	0V	0V
		13	14	15	16	17	18	19	20	21	22	23	24
		0V	0V	0V	0V	0V	5V	5V	5V	0.2V	5V	0V	0V
		25	26	27	28								
		0V	1.8V	2.5V	4.9V								

IC PIN NUMBER DC VOLTAGES									
SYMBOL NO.	DEVICE	1	2	3	4	5	6	7	8
U301 - 303	NE5532AN	0V	0V	0V	-11.8V	0V	0V	0V	12V

Schematic Diagram

SCHEMATIC DIAGRAM MODEL NO. RDA-980

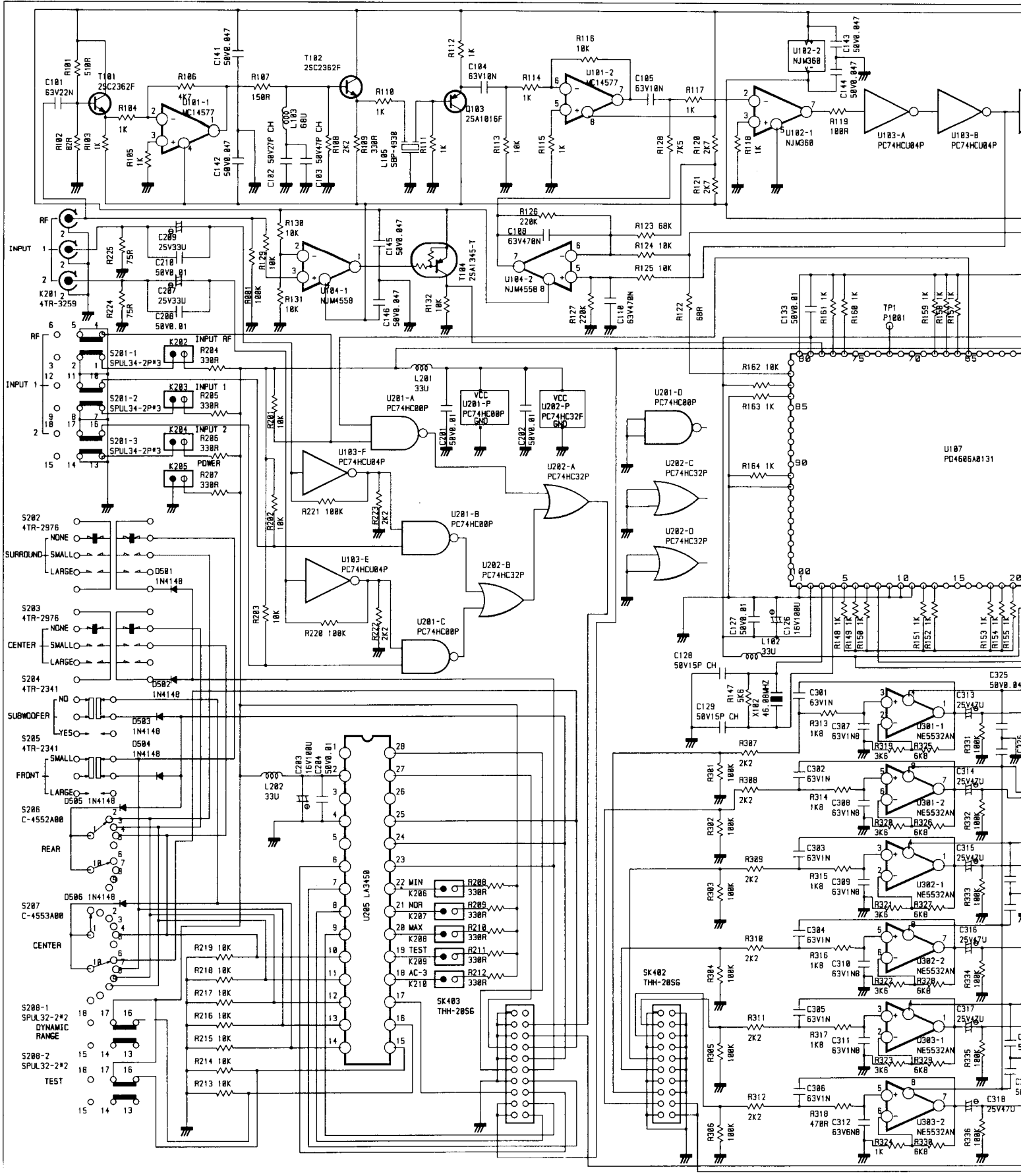

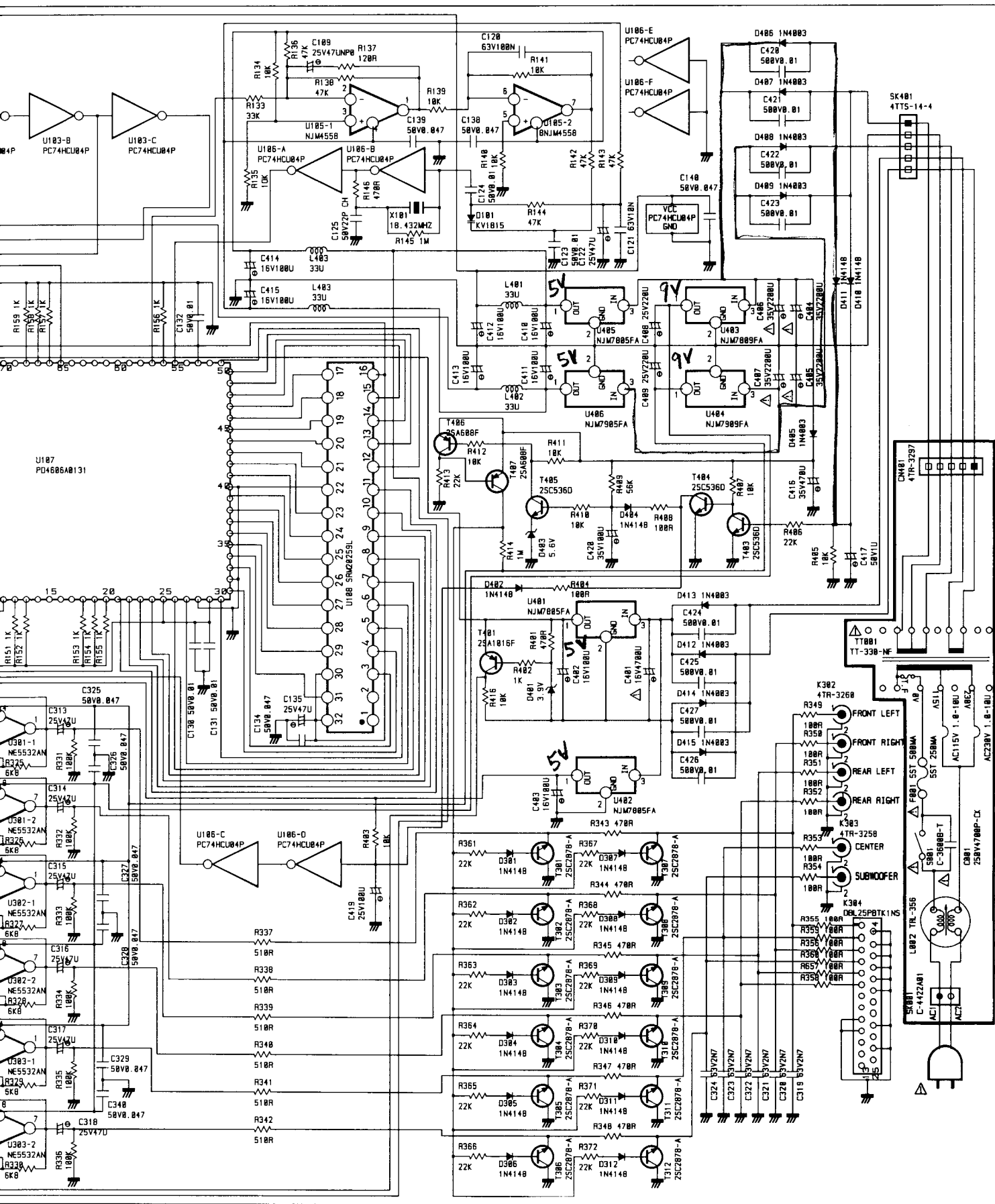

D412-415
INTERM.
DEAD
W/IN IT

Printed Circuit Boards (SOLDER SIDE)

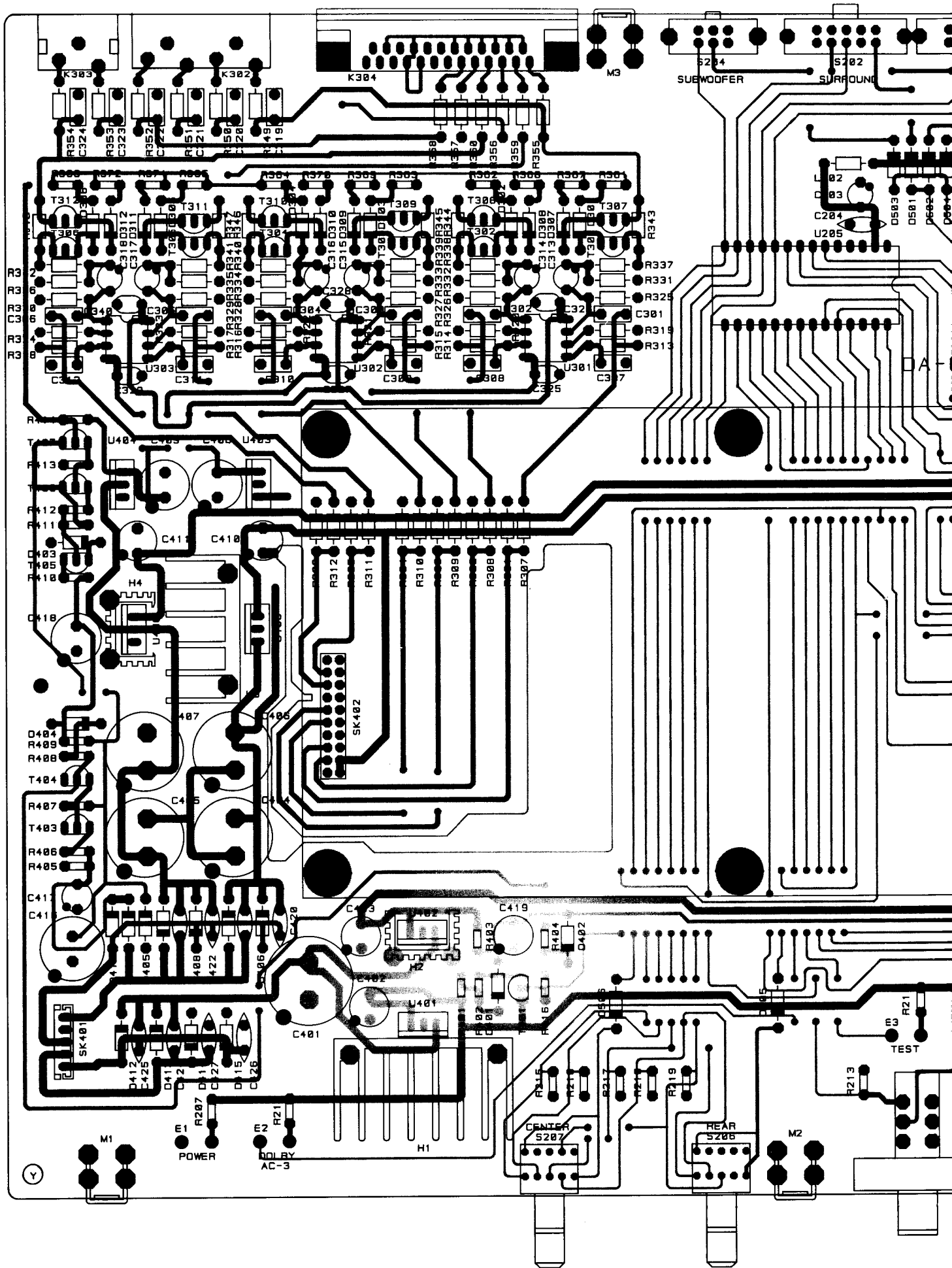

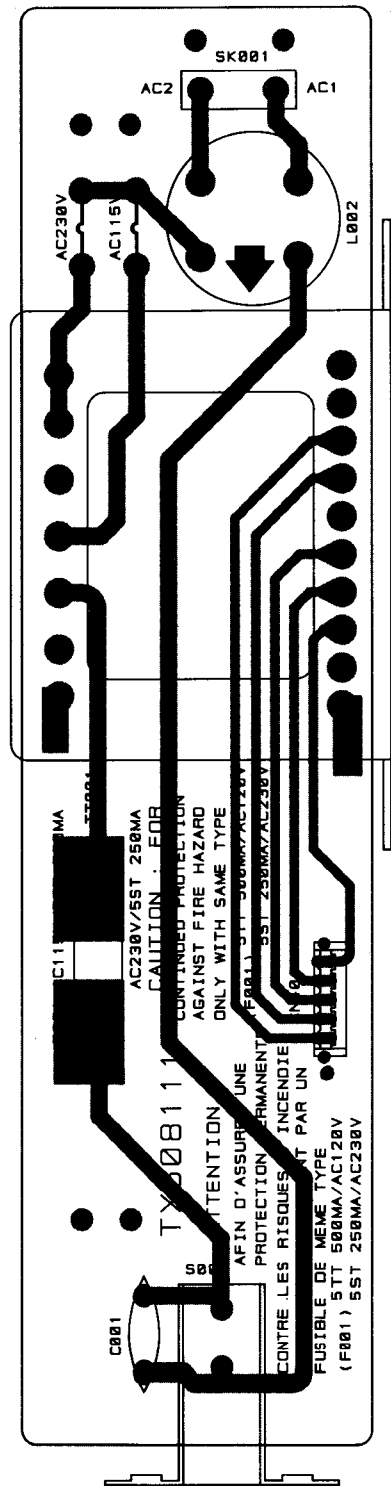
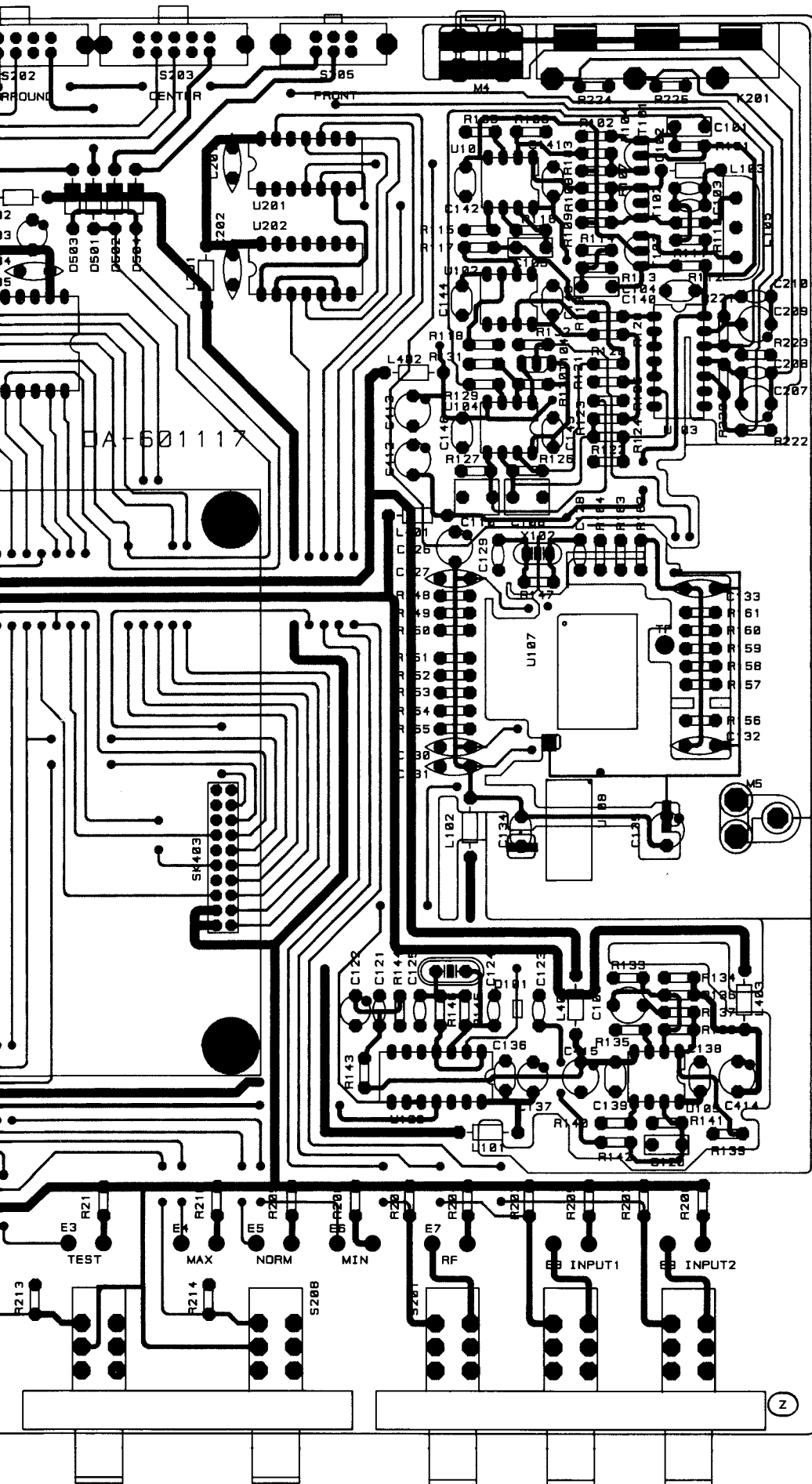

Printed Circuit Boards

(TOP SIDE)

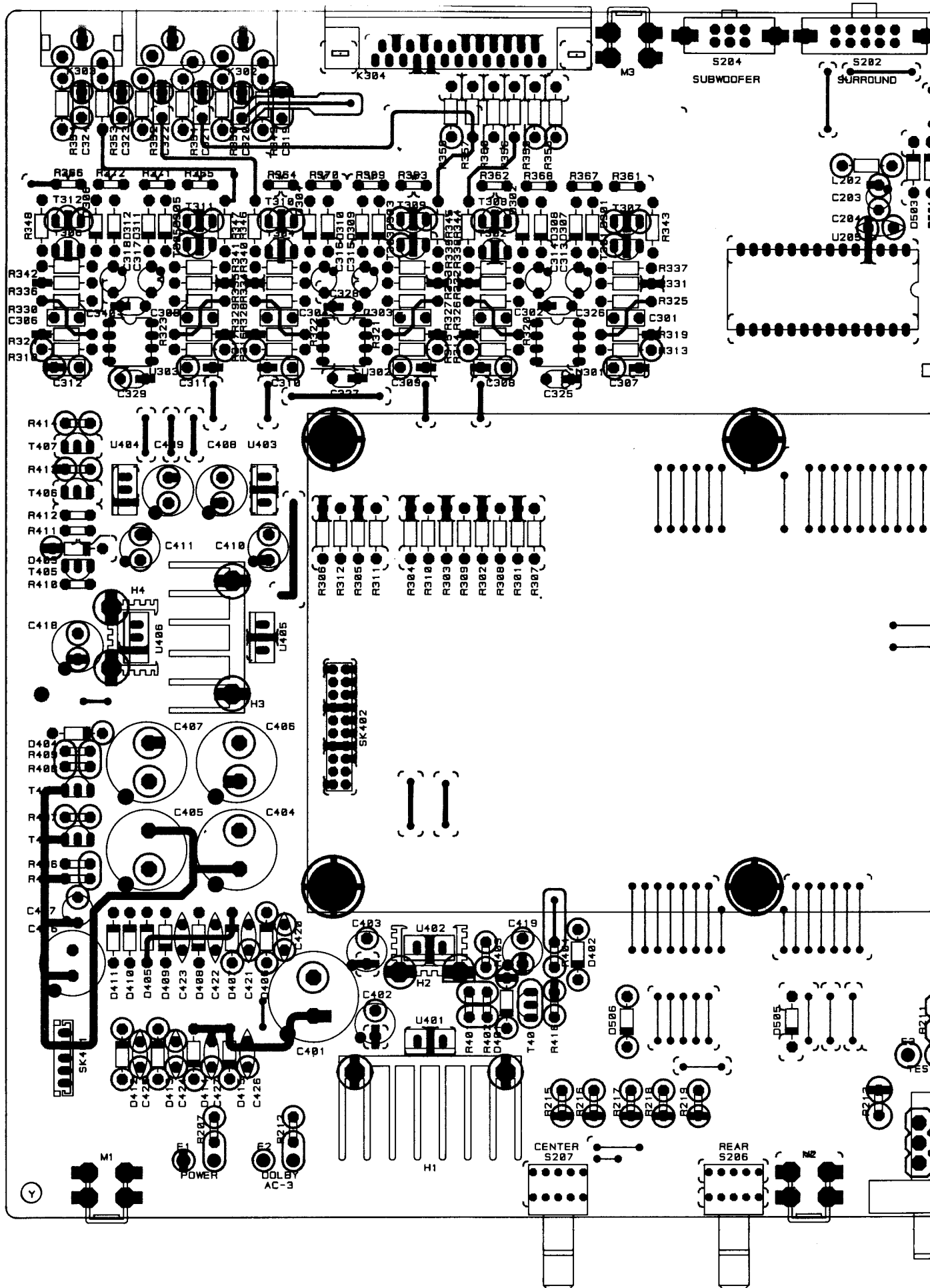

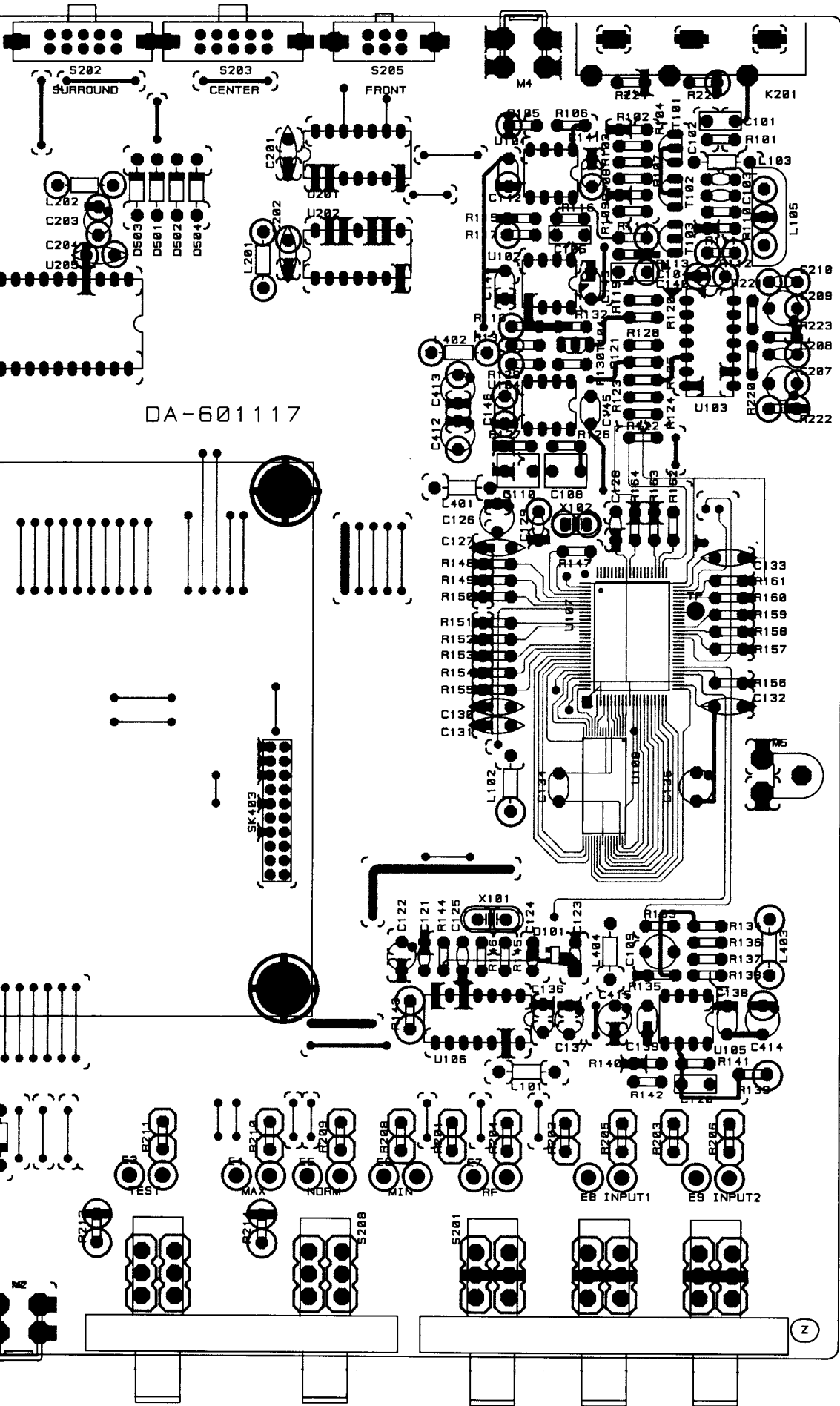

DA-601117

Parts List

NOTE: THE COMPONENTS IDENTIFIED BY Δ MARK ARE FOR SAFFTY. REPLACE ONLY WITH ORIGINAL PARTS. DO NOT SUBSTITUTE.

SYMBOL	PARTS NO.	DESCRIPTION	SYMBOL	PARTS NO.	DESCRIPTION
DA-601117 PCB ASSEMBLY					
R101	RD65100828	R,CARBON RD1/4SJT2-511	C121	CC41009462	CAP,CERAMIC 50V 0.01uF
R102	RD68209825	R,CARBON RD1/4SJT2-820	C122	CE44706258	CAP,ELEC. 25V 47uF
R103-105	RD61001820	R,CARBON RD1/4SJT2-102	C123,124	CC41009462	CAP,CERAMIC 50V 0.01uF
R106	RD64701828	R,CARBON RD1/4SJT2-472	C125	CC52212429	CAP,CERAMIC 50V 22P
R107	RD61500824	R,CARBON RD1/4SJT2-151	C126	CE41005166	CAP,ELEC. 16V 100uF
R108	RD62201828	R,CARBON RD1/4SJT2-222	C127	CC41009462	CAP,CERAMIC 50V 0.01uF
R109	RD63300826	R,CARBON RD1/4SJT2-331	C128,129	CC51512417	CAP,CERAMIC 50V 15P
R110-112	RD61001820	R,CARBON RD1/4SJT2-102	C130-133	CC41009462	CAP,CERAMIC 50V 0.01uF
R113	RD61002824	R,CARBON RD1/4SJT2-103	C134	CC45009456	CAP,CERAMIC 50V 0.05uF
R114,115	RD61001820	R,CARBON RD1/4SJT2-102	C135	CE44706258	CAP,ELEC. 25V 47uF
R116	RD61002824	R,CARBON RD1/4SJT2-103	C136	CC45009456	CAP,CERAMIC 50V 0.05uF
R117,118	RD61001820	R,CARBON RD1/4SJT2-102	C137	CE44706258	CAP,ELEC. 25V 47uF
R119	RD61000827	R,CARBON RD1/4SJT2-101	C138-146	CC45009456	CAP,CERAMIC 50V 0.05uF
R120,121	RD62701825	R,CARBON RD1/4SJT2-272	C201,202	CC41009462	CAP,CERAMIC 50V 0.01uF
R122	RD66809825	R,CARBON RD1/4SJT2-680	C203	CE41005166	CAP,ELEC. 16V 100uF
R123	RD66802820	R,CARBON RD1/4SJT2-683	C204	CC41009462	CAP,CERAMIC 50V 0.01uF
R124,125	RD61002824	R,CARBON RD1/4SJT2-103	C207	CE43306467	CAP,ELEC. 50V 33uF
R126,127	RD62203825	R,CARBON RD1/4SJT2-224	C208	CC41009462	CAP,CERAMIC 50V 0.01uF
R128	RD67501826	R,CARBON RD1/4SJT2-752	C209	CE43306467	CAP,ELEC. 50V 33uF
R129-132	RD61002824	R,CARBON RD1/4SJT2-103	C210	CC41009462	CAP,CERAMIC 50V 0.01uF
R133	RD63302823	R,CARBON RD1/4SJT2-333	C301-306	CQ61010421	CAP,M.P 63V 1000PF
R134,135	RD61002824	R,CARBON RD1/4SJT2-103	C307-311	CQ61810425	CAP,M.P 63V 1800PF
R136	RD64702821	R,CARBON RD1/4SJT2-473	C312	CQ66810427	CAP,M.P 63V 6800PF
R137	RD61200828	R,CARBON RD1/4SJT2-121	C313-318	CE44706258	CAP,ELEC. 25V 47uF
R138	RD64702821	R,CARBON RD1/4SJT2-473	C319-324	CQ62710426	CAP,M.P 63V 2700PF
R139-141	RD61002824	R,CARBON RD1/4SJT2-103	C325-329	CC45009456	CAP,CERAMIC 50V 0.05uF
R142-144	RD64702821	R,CARBON RD1/4SJT2-473	C340	CC45009456	CAP,CERAMIC 50V 0.05uF
R145	RD61004821	R,CARBON RD1/4SJT2-105	C401	CE04704767	CAP,ELEC. 16V 4700uF Δ
R146	RD64700824	R,CARBON RD1/4SJT2-471	C402,403	CE41005166	CAP,ELEC. 16V 100uF
R147	RD65601829	R,CARBON RD1/4SJT2-562	C404-407	CE02204354	CAP,ELEC. 35V 2200uF Δ
R148-161	RD61001820	R,CARBON RD1/4SJT2-102	C408,409	CE02205255	CAP,ELEC. 25V 220uF
R162	RD61002824	R,CARBON RD1/4SJT2-103	C410-415	CE41005166	CAP,ELEC. 16V 100uF
R163,164	RD61001820	R,CARBON RD1/4SJT2-102	C416	CE04705358	CAP,ELEC. 35V 470uF
R201-203	RD61002824	R,CARBON RD1/4SJT2-103	C417	CE41007503	CAP,ELEC. 50V 1uF
R204-212	RD63300826	R,CARBON RD1/4SJT2-331	C418	CE41005567	CAP,ELEC. 35V 100uF
R213-219	RD61002824	R,CARBON RD1/4SJT2-103	C419	CE41005166	CAP,ELEC. 16V 100uF
R220,221	RD61003828	R,CARBON RD1/4SJT2-104	L101,102	LM00000668	MICRO INDUCTOR TRL-392
R222,223	RD62201828	R,CARBON RD1/4SJT2-222	L103	LM00000693	MICRO INDUCTOR TLAL03T680K
R224,225	RD67509825	R,CARBON RD1/4SJT2-750	L105	LC00000010	BAND PASS FILTER ATF7001A
R301-306	RL81003618	R,STANDARD MK2100KFE	L201,202	LM00000668	MICRO INDUCTOR AL0307ST-330J-S-A
R307-312	RL82201618	R,STANDARD MK202K2FE	L401-404	LM00000668	MICRO INDUCTOR AL0307ST-330J-S-A
R313-317	RL81801614	R,STANDARD MK201K8FE	D101	DD90000066	DIODE KV1851
R318	RL84700614	R,STANDARD MK2470RFE	D301-312	DD80000021	DIODE IN4148-86
R319-323	RL83601616	R,STANDARD MK203K6FE	D401	DD20000387	DIODE, ZENER RD-3.9E
R324	RL81001610	R,STANDARD MK2001KFE	D402	DD80000021	DIODE IN4148-86
R325-330	RL86801616	R,STANDARD MK206K8FE	D403	DD20000478	DIODE RD5.6JS-T1
R331-336	RL81003618	R,STANDARD MK2100KFE	D404	DD80000021	DIODE IN4148-86
R337-342	RL85100618	R,STANDARD MK2510RFE	D405-409	DD80000010	DIODE IN4003-TE
R343-348	RL84700614	R,STANDARD MK2470RFE	D410,411	DD80000021	DIODE IN4148-86
R361-372	RD62202821	R,CARBON RD1/4SJT2-223	D412-415	DD80000010	DIODE IN4003-TB
R401	RD64700824	R,CARBON RD1/4SJT2-471	D501-506	DD80000021	DIODE IN4148-86
R402	RD61001820	R,CARBON RD1/4SJT2-102	X101	DD60000489	CRYSTAL OSC. 49U18.432
R403	RD61002824	R,CARBON RD1/4SJT2-103	X102	DD60000490	CRYSTAL OSC. VD-70684
R404	RD61000827	R,CARBON RD1/4SJT2-101	T102,102	TR31000083	TRANSISTOR 2SC2362F
R405	RD61002824	R,CARBON RD1/4SJT2-103	T103	TR11000039	TRANSISTOR 2SA1016F
R406	RD62202821	R,CARBON RD1/4SJT2-223	T104	TR11000064	TRANSISTOR 2SA1345-AC
R407	RD61002824	R,CARBON RD1/4SJT2-103	T301-312	TR31000149	TRANSISTOR 2SC2878-A/B
R408	RD61000827	R,CARBON RD1/4SJT2-101	T401	TR11000015	TRANSISTOR 2SA608KF
R409	RD65602822	R,CARBON RD1/4SJT2-563	T403-405	TR31000034	TRANSISTOR 2SC536G-NP-AA
R410-412	RD61002824	R,CARBON RD1/4SJT2-103	T406,407	TR11000015	TRANSISTOR 2SA608KF/KG
R413	RD61003828	R,CARBON RD1/4SJT2-104	U101	IC00004463	IC MC14577CP
R414	RD61004821	R,CARBON RD1/4SJT2-105	U102	IC00004475	IC NJM360D
R416	RD61001820	R,CARBON RD1/4SJT2-102	U103	IC00003689	IC TC74HCU04AP
C101	CQ62209427	CAP,M.P 63V 22000P	U104,105	IC00000019	IC LA6458D
C102	CC54712429	CAP,CERAMIC 50V 47P	U106	IC00003689	IC TC74HCU04AP
C103	CC52712426	CAP,CERAMIC 50V 27P	U107	IC00004487	IC PD4606A
C104,105	CQ61009420	CAP,M.P BF014D0103J	U108	IC00004499	IC SRM20259LTM-10
C108	CQ64708423	CAP,M.P 63V 470NF	U201	IC00004505	IC TC74HC32AP
C110	CQ64708423	CAP,M.P 63V 470NF	U202	IC00003823	IC TC74HC08AP
C120	CQ61008426	CAP,M.P 63V 100NF	U205	IC00004517	IC PIC16C57-XT/P
			U301-303	IC00001693	IC NE5532AN
			U401,402	IC00003630	IC NJM7805FA

Parts List

SYMBOL	PARTS NO.	DESCRIPTION
U403	IC00003641	IC NJM7809FA
U404	IC00003665	IC NJM7909FA
U405	IC00003630	IC NJM7805FA
U406	IC00004426	IC NJM7905FA
S201	SH13000504	3 KEY PUSH SW 4TR-3246
S202,203	SH20000575	SLIDE SW SS010-P823BCB-PA9
S204,205	SH20000563	SLIDE SW SS010-P022BAM-PA9
S206	SH30000651	FUNCTION SW C-4552A00
S207	SH30000663	FUNCTION SW C-4553A00
S208	SH13000516	3 KEY PUSH SW 4TR-3247
TX608111 PCB ASSEMBLY		
C001	CK00000035	SPARK KILLER DE7150F472M [△]
L002	LC23560006	LINE FILTER COIL TRL-356
S001	SH40000120	POWER SW C-3600B-T [△]
OTHERS		
AB00000640		BOTTOM BOARD 4TQN-12C#2
AF60000040		FRONT CHASSIS RK3-02A00T
AR60000059		PRINTED REAR CHASSIS TRP-714
AS01000350		SIDE CHASSIS 3TQG-1C#2
AS01000385		SIDE CHASSIS 3TQG-1C#3
PC00000138		DSP MODULE AC-3 DSP BOARD
PT33010100		POWER TRANSFORMER TT-330-NF [△]
FT00000229		PLASTIC FOOT 4TSH-19#2 50F _x 14H
SB00001381		P.V.C SHIELD BOARD 4TR-3272
SC00000027		AC CORD STOPPER SR-4N-4 [△]
SP10007574		P.T SUPPORT RK4-07A00T
CD00000218		AC CORD SPT-2 AWG#18 4TR-670#4 -U,C,A, [△]
CD00000322		AC POWER CORD 4TR-2757 -D [△]
CD00000048		AC POWER CORD 4TR-1037 - E1,E2,E3,E5,E6, E8,E9,H,S1 [△]
CD00000565		AC POWER CORD 4TR-3300 -K1,E4 [△]
CD00000115		AC POWER CORD C-3763-T -G1,Y2 [△]
NP00001949		NAME STICKER AC-120V 4TR-2828A#1 TNP-382
NP00002012		NAME STICKER AC-100V 4TR-2828A#6 TNP-391
NP00002140		NAME STICKER AC-220V-240V 4TR-2828A#11 TNP-398
FU25000016		FUSE 250V 500mA UL/CSA [△]
FU23000384		FUSE 250V T250mA (S) [△]
AA60000165		FRONT PANEL RK3-01A00T TFP-787
BU00001145		POWER RING W/LED 4TQF-13 14x14
KB20002681		POWER BUTTON 4TQF-15 14x14
OM10001260		ORNAMENTAL SIDE BOARD 4TR-2797#1
DD40000095		LED SEL1124R
DD40001580		LED LN230RPP
OM70000065		PUSH BUTTON CONNECTOR 4TTL-15
SN00000179		BUTTON SPRING 4TR-1988A#2 10F
AU00001468		TOP COVER POLY QF3-03A03T
KB10001813		KNOB 11F 4TSA-7#2
KB20003132		PUSH BUTTON 4TPG-8
SR00000882		UPPER COVER SPACER 4TR-2418
MN10004169		OWNER'S MANUAL RDA-980
PL00001087		STYROL SIDE MOULDING 2TTE-8B#2 TZ-164-1
TN10005145		INSIDE CARTON RDA-980 4TR-3273