



AK4430

192kHz 24-Bit Stereo $\Delta\Sigma$ DAC with 2Vrms Output

GENERAL DESCRIPTION

The AK4430 is 3.3V 24-bit stereo DAC with an integrated 2Vrms output buffer. A charge pump in the buffer develops an internal negative power supply rail that enables a ground-referenced 2Vrms output. Using AKM's multi bit modulator architecture, the AK4430 delivers a wide dynamic range while preserving linearity for improved THD+N performance. The AK4430 integrates a combination of switched-capacitor and continuous-time filters, increasing performance for systems with excessive clock jitter. The 24-bit word length and 192kHz sampling rate make this part ideal for a wide range of consumer audio applications, such as portable A/V players, set-top boxes, and digital televisions. The AK4430 is offered in a space saving 16pin TSSOP package.

FEATURES

- Sampling Rate Ranging from 8kHz to 192kHz
- 128 times Oversampling (Normal Speed Mode)
- 64 times Oversampling (Double Speed Mode)
- 32 times Oversampling (Quad Speed Mode)
- 24-Bit 8 times FIR Digital Filter
- Switched-Capacitor Filter with High Tolerance to Clock Jitter
- Single Ended 2Vrms Output Buffer
- Soft mute
- I/F format: 24-bit MSB justified, I²S
- Master clock: 512fs, 768fs or 1152fs (Normal Speed Mode)
256fs or 384fs (Double Speed Mode)
128fs or 192fs (Quad Speed Mode)
- THD+N: -91dB
- Dynamic Range: 104dB
- Automatic Power-on Reset Circuit
- Power supply: +3.0 ~ +3.6V
- Ta = -20 to 85°C
- Small Package: 16pin TSSOP (6.4mm x 5.0mm)

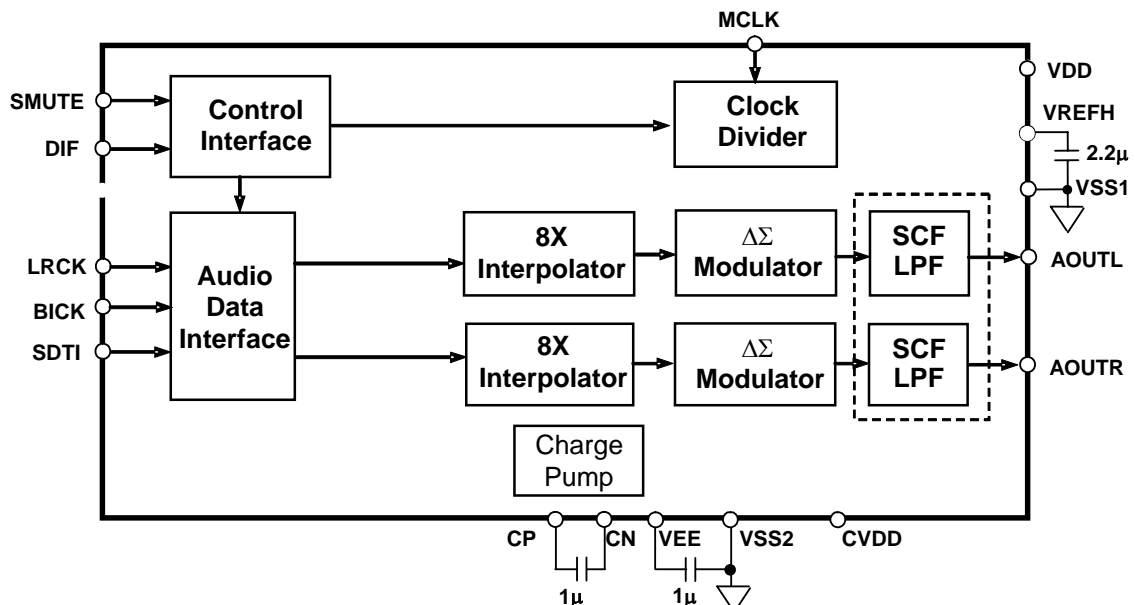

■ Ordering Guide

AK4430ET
AKD4430

-20 ~ +85°C

16pin TSSOP (0.65mm pitch)
Evaluation Board for AK4430

■ Pin Layout

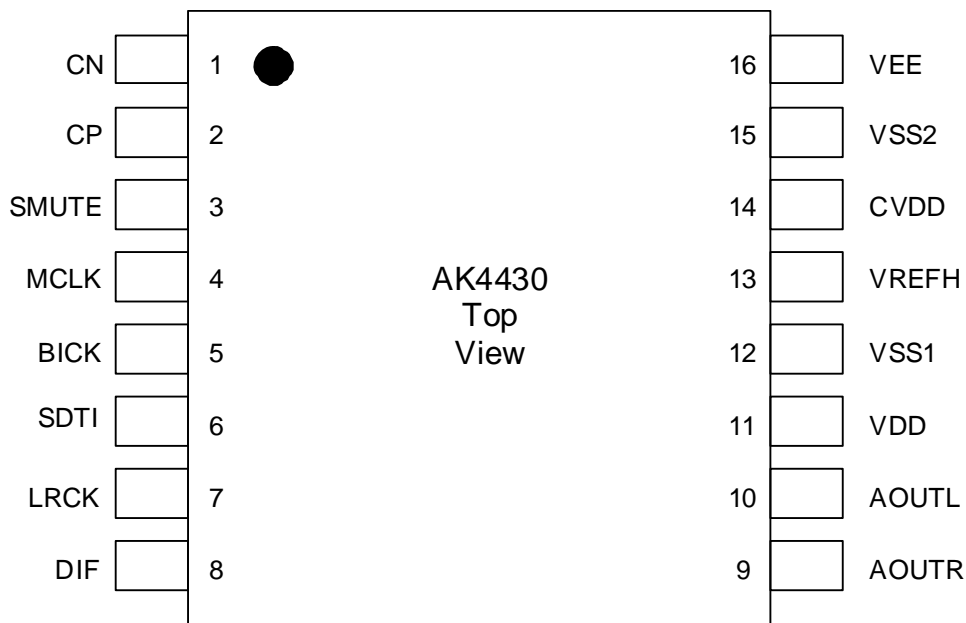

■ Compatibility with the AK4420, AK4424, AK4421 and AK4421A

		AK4420	AK4424	AK4421	AK4421A	AK4430
Power Supply		+4.5 ~ +5.5V	+4.5 ~ +5.5V	+3.0 ~ +3.6V	+3.0 ~ +3.6V	+3.0 ~ +3.6V
Digital de-emphasis		-	X	-	-	-
I/F format		24-bit MSB/I ² S	I ² S	24-bit MSB/I ² S	24-bit MSB/I ² S	24-bit MSB/I ² S
Pin out	Pin#3	SMUTE	DEM	SMUTE	SMUTE	SMUTE
	Pin#8	DIF	SMUTE	DIF	DIF*	DIF*
	Pin#13	DZF	DZF	DZF	DZF	VREFH
THD+N		-92dB	-92dB	-92dB (-3dBFS)	-92dB	-91dB
DR		105dB	105dB	102dB	102dB	104dB
Operating Temperature		ET: -20 ~ +85°C VT: -40 ~ +85°C	ET: -20 ~ +85°C	ET: -20 ~ +85°C	ET: -20 ~ +85°C	ET: -20 ~ +85°C

(-: Not available, X: Available)

*: Internal pull up (100kΩ)

PIN/FUNCTION

No.	Pin Name	I/O	Function
1	CN	I	Negative Charge Pump Capacitor Terminal Pin Connect to CP with a 1.0μF low ESR (Equivalent Series Resistance) capacitor over temperature. When this capacitor is polarized, the positive polarity pin should be connected to the CP pin. Non-polarized capacitors can also be used.
2	CP	I	Positive Charge Pump Capacitor Terminal Pin Connect to CN with a 1.0μF low ESR (Equivalent Series Resistance) capacitor over temperature. When this capacitor is polarized, the positive polarity pin should be connected to the CP pin. Non-polarized capacitors can also be used.
3	SMUTE	I	Soft Mute Enable Pin (Internal pull down: 100kΩ) “H”: Enable, “L”: Disable
4	MCLK	I	Master Clock Input Pin
5	BICK	I	Audio Serial Data Clock Pin
6	SDTI	I	Audio Serial Data Input Pin
7	LRCK	I	L/R Clock Pin
8	DIF	I	Audio Data Interface Format Pin (Internal pull up: 100kΩ) “L”: 24-bit MSB Justified, “H”: I ² S,
9	AOUTR	O	Right channel Analog Output Pin When MCLK or LRCK or BICK stops, outputs VSS(0V, typ).
10	AOUTL	O	Left channel Analog Output Pin When MCLK or LRCK or BICK stops, outputs VSS(0V, typ).
11	VDD	-	Power Supply Pin, 3.0V~3.6V
12	VSS1	-	Ground Pin 1
13	VREFH	O	Reference Output Pin Connect to VSS with a 2.2μF low ESR capacitor over all temperature.
14	CVDD	-	Charge Pump Power Supply Pin
15	VSS2	-	Ground Pin 2
16	VEE	O	Negative Voltage Output Pin Connect to VSS2 with a 1.0μF low ESR capacitor over temperature. When this capacitor is polarized, the positive polarity pin should be connected to the VSS2 pin. Non-polarized capacitors can also be used.

Note: All input pins except for the CN, CP, SMUTE and DIF pins should not be left floating.

ABSOLUTE MAXIMUM RATINGS

(VSS1=VSS2=0V; [Note 1](#))

Parameter	Symbol	min	max	Units
Power Supply	VDD	-0.3	+4.0	V
	CVDD	-0.3	+4.0	V
Input Current (any pins except for supplies)	IIN	-	±10	mA
Input Voltage (Note 3)	VIND	-0.3	VDD+0.3	V
Ambient Operating Temperature	Ta	-20	85	°C
Storage Temperature	Tstg	-65	150	°C

Note 1. All voltages with respect to ground.

Note 2. VSS1, VSS2 connect to the same analog ground.

Note 3. SMUTE, MCLK, BICK, LRCK, SDTI and DIF pins

WARNING: Operation at or beyond these limits may result in permanent damage to the device.
Normal operation is not guaranteed at these extremes.

RECOMMENDED OPERATING CONDITIONS

(VSS1=VSS2=0V; [Note 1](#))

Parameter	Symbol	min	typ	max	Units
Power Supply	VDD	+3.0	+3.3	+3.6	V
	CVDD		VDD		

Note 4. CVDD should be equal to VDD.

*AKM assumes no responsibility for the usage beyond the conditions in this datasheet.

ANALOG CHARACTERISTICS

(Ta = 25°C; VDD=CVDD = +3.3V; fs = 44.1 kHz; BICK = 64fs; Signal Frequency = 1 kHz;
24bit Input Data; Measurement frequency = 20Hz ~ 20kHz; Ri ≥5kΩ, unless otherwise specified)

Parameter	min	typ	max	Units	
Resolution			24	Bits	
Dynamic Characteristics (Note 5)					
THD+N	fs=44.1kHz, BW=20kHz	-	-91	-82	dB
	fs=96kHz, BW=40kHz	-	-91	-	dB
	fs=192kHz, BW=40kHz	-	-89	-	dB
Dynamic Range (-60dBFS with A-weighted, Note 6)	96	104	-	dB	
S/N (A-weighted, Note 7)	96	104	-	dB	
Interchannel Isolation (1kHz)	90	104	-	dB	
Interchannel Gain Mismatch	-	0.2	0.5	dB	
PSRR (Note 9)		62		dB	
DC Accuracy					
DC Offset (at output pin)	-5	0	+5	mV	
Gain Drift	-	100	-	ppm/°C	
Output Voltage (Note 8)	1.85	2.0	2.15	Vrms	
Load Capacitance (Note 10)	-	-	25	pF	
Load Resistance	5	-	-	kΩ	
Power Supplies					
Power Supply Current: (Note 11)					
Normal Operation (fs≤96kHz)		20	28	mA	
Normal Operation (fs=192kHz)		22	31	mA	
Power-Down Mode (Note 12)		10	100	μA	

Note 5. Measured by Audio Precision (System Two). Refer to the evaluation board manual.

Note 6. 98dB for 16-bit input data

Note 7. S/N does not depend on input data length.

Note 8. Full-scale voltage (0dB). Output voltage is proportional to the voltage of VDD

$$A_{OUT} (\text{typ.}@0\text{dB}) = 2V_{\text{rms}} \times V_{\text{DD}}/3.3.$$

Note 9. PSRR is applied to VDD and CVDD with 1kHz, 50mVpp.

Note 10. In case of driving capacitive load, inset a resistor between the output pin and the capacitive load.

Note 11. The current into VDD and CVDD.

Note 12. All digital inputs including clock pins (MCLK, BICK and LRCK) are fixed to VSS or VDD.

FILTER CHARACTERISTICS

(Ta = 25°C; VDD=CVDD = +3.0 ~ +3.6V; fs = 44.1 kHz)

Parameter	Symbol	min	typ	max	Units
Digital filter					
Passband	PB	0	22.05	20.0	kHz
		-		-	kHz
Stopband (Note 13)	SB	24.1			kHz
Passband Ripple	PR			± 0.01	dB
Stopband Attenuation	SA	64			dB
Group Delay (Note 14)	GD	-	24	-	1/fs
De-emphasis Filter					
Digital Filter + LPF					
Frequency Response(1kHz reference)					
fs=44.1kHz, 20Hz ~ 20.0kHz	FR	-	± 0.05	-	dB
fs=96kHz, 20Hz ~ 40.0kHz	FR	-	± 0.05	-	dB
fs=192kHz, 20Hz ~ 80.0kHz	FR	-	± 0.05	-	dB

Note 13. The passband and stopband frequencies scale with fs (system sampling rate).

For example, PB=0.4535×fs (@±0.05dB), SB=0.546×fs.

Note 14. Calculated delay time caused by the digital filter. This time is measured from setting the 16/24bit data of both channels to input register to the output of the analog signal.

DC CHARACTERISTICS

(Ta = 25°C; VDD=CVDD = +3.0 ~ +3.6V)

Parameter	Symbol	min	typ	max	Units
High-Level Input Voltage	VIH	70%VDD	-	-	V
Low-Level Input Voltage	VIL	-	-	30%VDD	V
Input Leakage Current (Note 15)	Iin	-	-	± 10	μA

Note 15. The SMUTE pin and DIF pin are not included. The SMUTE pin has an internal pull-down resistor (typ. 100kΩ) and the DIF pin has an internal pull-up resistor (typ. 100kΩ).

SWITCHING CHARACTERISTICS

(Ta = 25°C; VDD=CVDD = +3.0 ~ +3.6V)

Parameter	Symbol	min	typ	max	Units
Master Clock Frequency	fCLK	4.096	-	36.864	MHz
Duty Cycle	dCLK	40		60	%
LRCK Frequency					
Normal Speed Mode	fsn	8		48	kHz
Double Speed Mode	fsd	32		96	kHz
Quad Speed Mode	fsq	120		192	kHz
Duty Cycle	Duty	45		55	%
Audio Interface Timing					
BICK Period					
Normal Speed Mode	tBCK	1/128fsn			ns
Double Speed Mode	tBCK	1/64fsd			ns
Quad Speed Mode	tBCK	1/64fsq			ns
BICK Pulse Width Low	tBCKL	30			ns
Pulse Width High	tBCKH	30			ns
BICK “↑” to LRCK Edge (Note 16)	tBLR	20			ns
LRCK Edge to BICK “↑” (Note 16)	tLRB	20			ns
SDTI Hold Time	tSDH	20			ns
SDTI Setup Time	tSDS	20			ns

Note 16. BICK rising edge must not occur at the same time as LRCK edge.

■ Timing Diagram

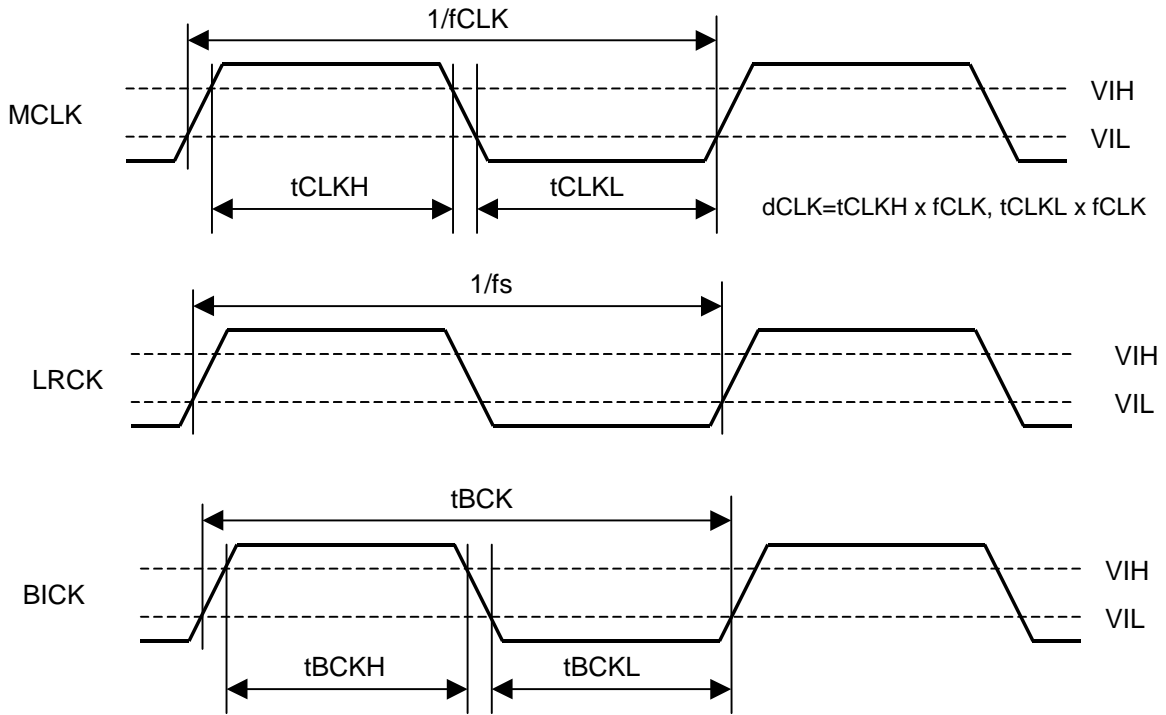

Figure 1. Clock Timing

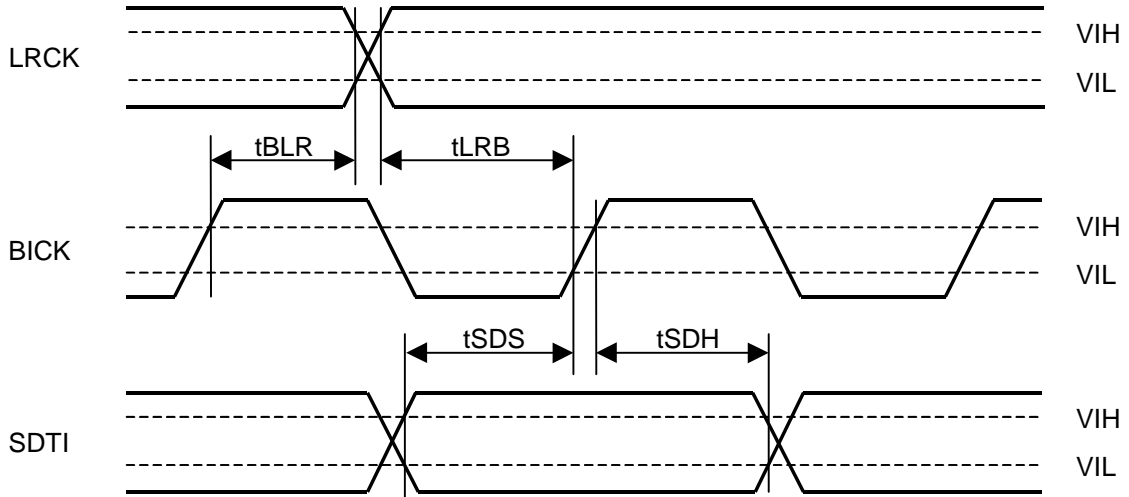

Figure 2. Serial Interface Timing

OPERATION OVERVIEW

■ System Clock

The external clocks required to operate the AK4430 are MCLK, LRCK, and BICK. The master clock (MCLK) should be synchronized with LRCK, but the phase is not critical. The MCLK is used to operate the digital interpolation filter and the delta-sigma modulator. Sampling speed and MCLK frequency are detected automatically, and then the internal master clock is set to the appropriate frequency (Table 1).

The AK4430 is automatically placed in power saving mode when MCLK, LRCK and BICK stop during normal operation mode, and the analog output goes to 0V(typ). When MCLK, LRCK and BICK are input again, the AK4430 is powered up. After exiting reset following power-up, the AK4430 is not fully operational until MCLK, LRCK and BICK are input.

LRCK fs	MCLK (MHz)							Sampling Speed
	128fs	192fs	256fs	384fs	512fs	768fs	1152fs	
32.0kHz	-	-	-	-	16.3840	24.5760	36.8640	Normal
44.1kHz	-	-	-	-	22.5792	33.8688	-	
48.0kHz	-	-	-	-	24.5760	36.8640	-	
32.0kHz			8.192	12.288				Double
44.1kHz			11.2896	16.9344				
48.0kHz			12.288	18.432				
88.2kHz	-	-	22.5792	33.8688	-	-	-	
96.0kHz	-	-	24.5760	36.8640	-	-	-	Quad
176.4kHz	22.5792	33.8688	-	-	-	-	-	
192.0kHz	24.5760	36.8640	-	-	-	-	-	

Table 1. System Clock Example

When MCLK= 256fs/384fs, the Auto Setting Mode supports sampling rate of 32kHz~96kHz (Table 1). However, when the sampling rate is 32kHz~48kHz, DR and S/N will degrade as compared to when MCLK= 512fs/768fs (Table 2).

MCLK	DR,S/N
256fs/384fs	101dB
512fs/768fs	104dB

Table 2. Relationship between MCLK frequency and DR, S/N (fs= 44.1kHz)

■ Audio Serial Interface Format

The audio data is shifted in via the SDTI pin using the BICK and LRCK inputs. The AK4430 supports two formats as shown in Table 3. The serial data is MSB-first, two's complement format and it is latched on the rising edge of BICK. It can be used for 16/20 bit I²S formats by zeroing the unused LSBs.

Mode	DIF pin	SDTI Format	BICK	Figure
0	L	24bit MSB justified	≥48fs	Figure 3
1	H	24bit I ² S	≥48fs	Figure 4

Table 3. Audio Data Format

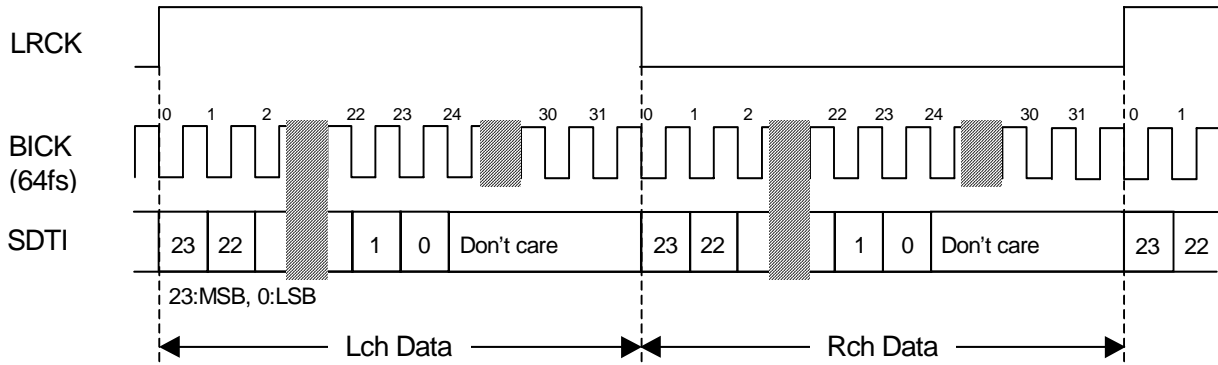

Figure 3. Mode 0 Timing

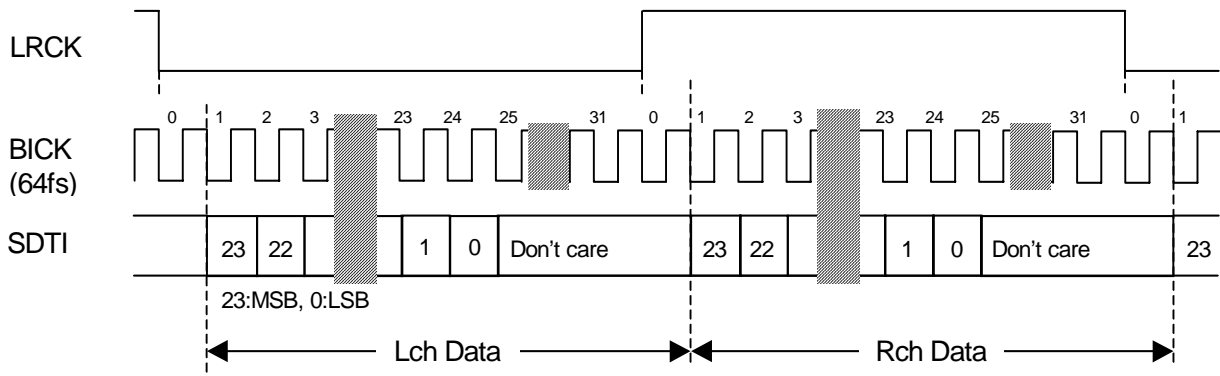

Figure 4. Mode 1 Timing

■ Analog Output Block

The internal negative power supply generation circuit (Figure 5) provides a negative power supply for the internal 2Vrms amplifier. It allows the AK4430 to output an audio signal centered at VSS (0V, typ) as shown in Figure 6. The negative power generation circuit (Figure 5) needs 1.0uF capacitors (Ca, Cb) with low ESR (Equivalent Series Resistance). If this capacitor is polarized, the positive polarity pin should be connected to the CP and VSS2 pins. This circuit operates by clocks generated from MCLK. When MCLK stops, the AK4430 is placed in reset mode automatically and the analog outputs settle to VSS (0V, typ).

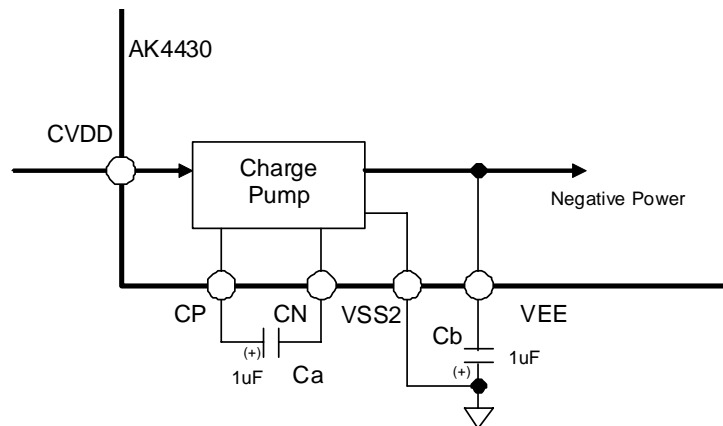

Figure 5. Negative Power Generation Circuit

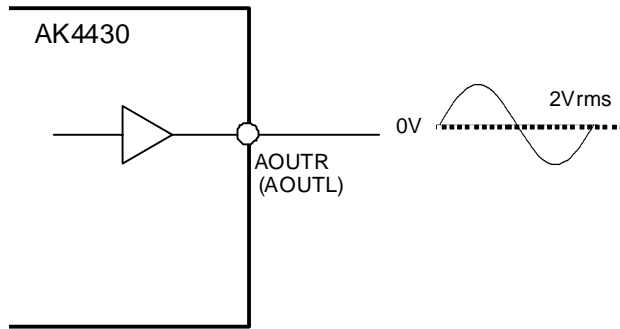
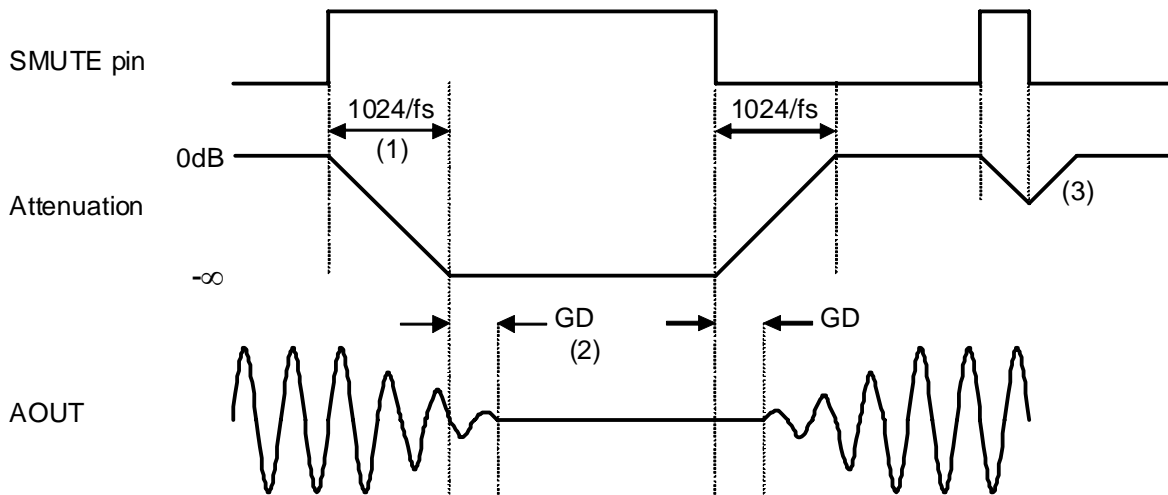

Figure 6. Audio Signal Output

■ Soft Mute Operation

Soft mute operation is performed in the digital domain. When the SMUTE pin is set “H”, the output signal is attenuated to $-\infty$ in 1024 LRCK cycles. When the SMUTE pin is returned to “L”, the mute is cancelled and the output attenuation gradually changes to 0dB in 1024 LRCK cycles. If the soft mute is cancelled within the 1024 LRCK cycles after starting this operation, the attenuation is discontinued and it is returned to 0dB by the same cycle. Soft mute is effective for changing the signal source without stopping the signal transmission. In one cycle of LRCK, eight “H” pulses or more must not be input to the SMUTE pin.



Notes:

- (1) The time for input data attenuation to $-\infty$ is :
 Normal Speed Mode: 1024 LRCK cycles (1024/fs).
 Double Speed Mode: 2048 LRCK cycles (2048/fs).
 Quad Speed Mode : 4096 LRCK cycles (4096/fs).
- (2) The analog output corresponding to a specific digital input has a group delay, GD.
- (3) If soft mute is cancelled before attenuating to $-\infty$ after starting the operation, the attenuation is discontinued and returned to 0dB in the same cycle.

Figure 7. Soft Mute Function

■ System Reset

The AK4430 is in power down mode upon power-up. The MCLK should be input after the power supplies are ramped up. The AK4430 is in power-down mode until LRCK are input.

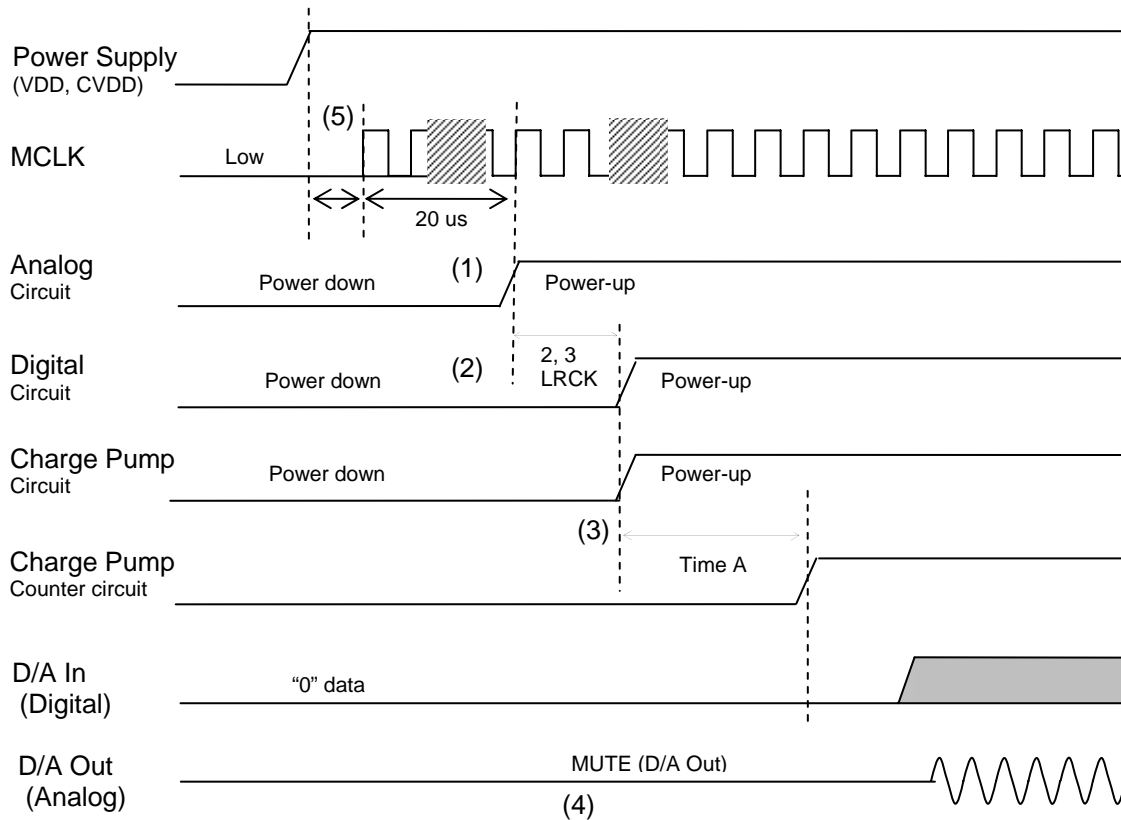

Notes:

- (1) Approximately 20us after a MCLK input is detected, the internal analog circuit is powered-up.
- (2) The digital circuit is powered-up after 2 or 3 LRCK cycles following the detection of MCLK.
- (3) The charge pump counter starts after the charge pump circuit is powered-up. The DAC outputs a valid analog signal after Time A.
 Time A = 176/fs: Normal speed mode
 Time A = 352/fs: Double speed mode
 Time A = 704/fs: Quad speed mode
- (4) No audible click noise occurs under normal conditions.
- (5) The power supply must be powered-up when the MCLK pin is "L". MCLK must be input after 20us when the power supply voltage achieves 80% of VDD. If not, click noise may occur at different time from this figure.

Figure 8. System Reset Diagram

■ Reset Function

When the MCLK or LRCK or BICK stops, the AK4430 is placed in reset mode and its analog outputs are set to VSS (0V, typ). When the MCLK and LRCK, BICK are restarted, the AK4430 returns to normal operation mode.

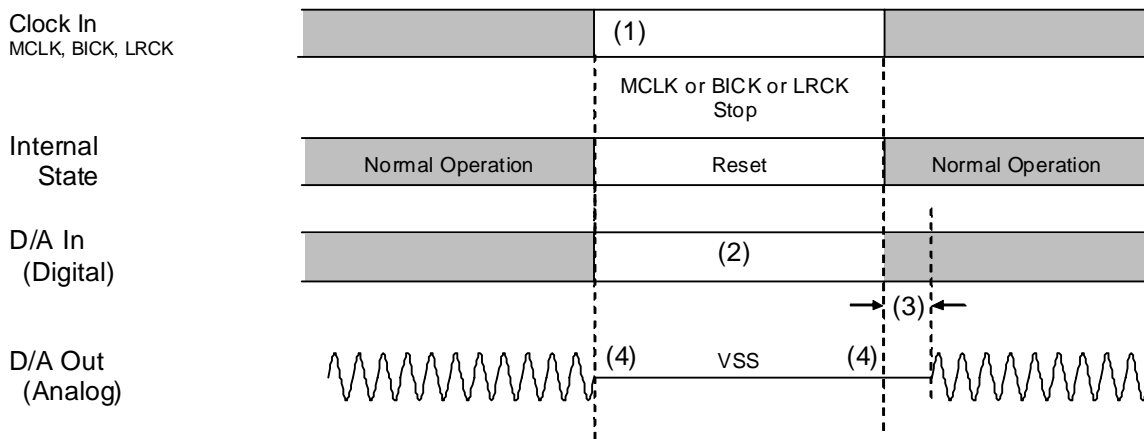

Notes:

- (1) Clocks (MCLK, BICK, LRCK) can be stopped in the reset mode (MCLK, LRCK or BICK is stopped).
- (2) Digital data can be stopped. The click noise after MCLK, LRCK and BICK are input again can be reduced by inputting the "0" data during this period.
- (3) Digital data is muted for about 180/fs (in Normal speed mode) from the timing when a clock starts, and then the analog data is output after GD.
- (4) No audible click noise occurs under normal conditions.

Figure 9. Reset Timing Example

SYSTEM DESIGN

Figure 10 shows the system connection diagram. An evaluation board (AKD4430) is available for fast evaluation as well as suggestions for peripheral circuitry.

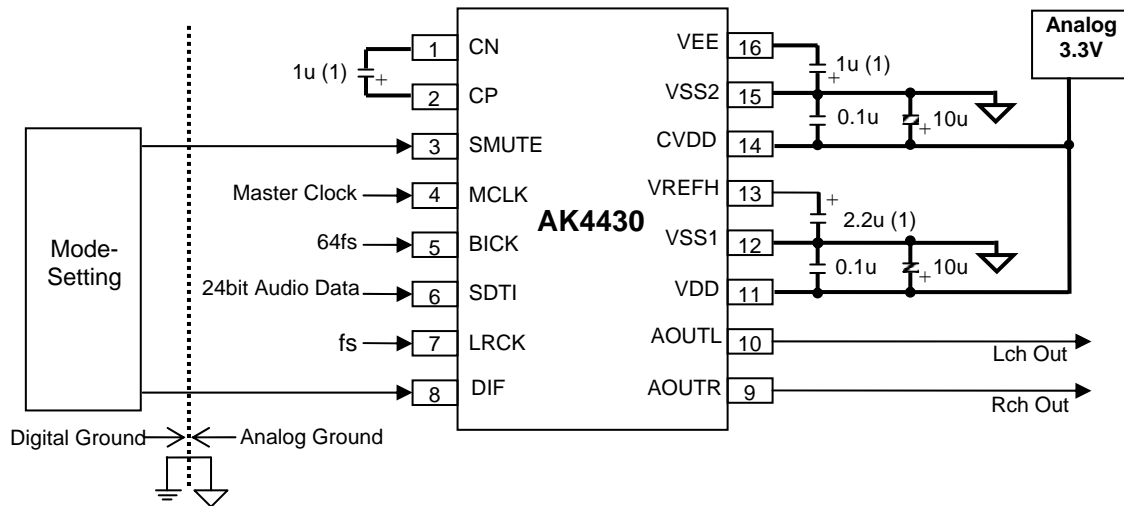

Figure 10. Typical Connection Diagram

Note:

- (1) Use low ESR (Equivalent Series Resistance) capacitors. When using polarized capacitors, the positive polarity pin should be connected to the CP, VSS2 and VREFH pins.
- (2) VSS1 and VSS2 should be separated from digital system ground.
- (3) Digital input pins should not be allowed to float.

1. Grounding and Power Supply Decoupling

VDD and CVDD are supplied from the analog supply and should be separated from the system digital supply. Decoupling capacitors, especially 0.1 μ F ceramic capacitors for high frequency bypass, should be placed as near to VDD and CVDD as possible. The VSS1 and VSS2 must be connected to the same analog ground plane. **Power-up sequence between VDD and CVDD is not critical.**

2. Analog Outputs

The analog outputs are single-ended and centered at the VSS (ground) voltage. The output signal range is typically 2.0Vrms (typ @VDD=3.3V). The internal switched-capacitor filter (SCF) and continuous-time filter (CTF) attenuate the noise generated by the delta-sigma modulator beyond the audio passband. Using single a 1st-order LPF (Figure 11) can reduce noise beyond the audio passband.

The output voltage is a positive full scale for 7FFFFFFH (@24bit data) and a negative full scale for 800000H (@24bit data). The ideal output is 0V (VSS) voltage for 000000H (@24bit data). The DC offset is \pm 5mV or less.

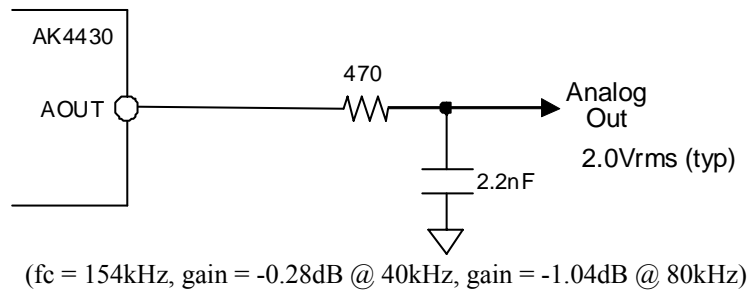
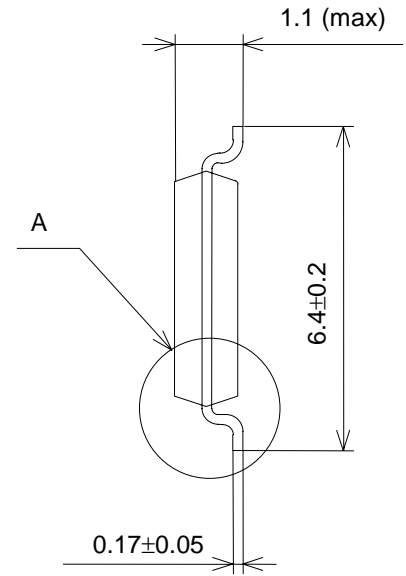
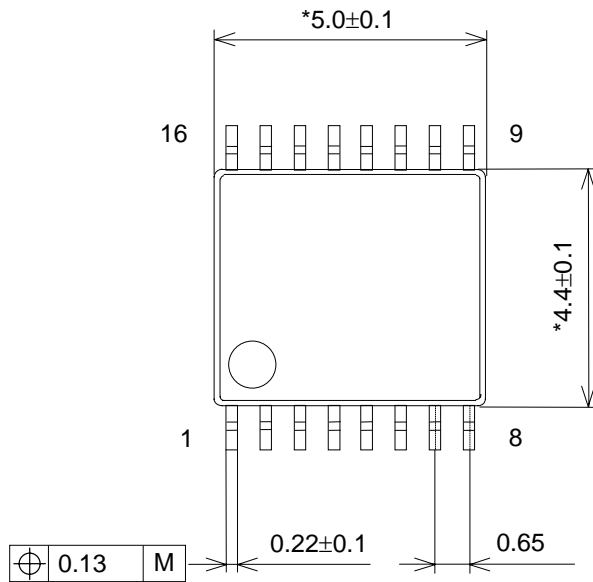

Figure 11. External 1st order LPF Circuit Example

PACKAGE

16pin TSSOP (Unit: mm)



Detail A

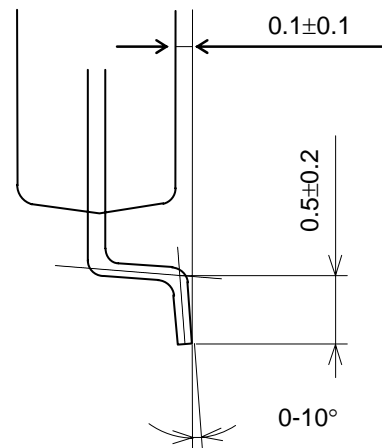
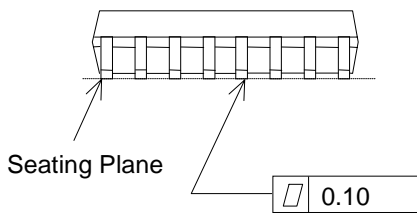

NOTE: Dimension "*" does not include mold flash.

■ Package & Lead frame material

Package molding compound:	Epoxy, Halogen (bromine and chlorine) free
Lead frame material:	Cu
Lead frame surface treatment:	Solder (Pb free) plate

MARKING

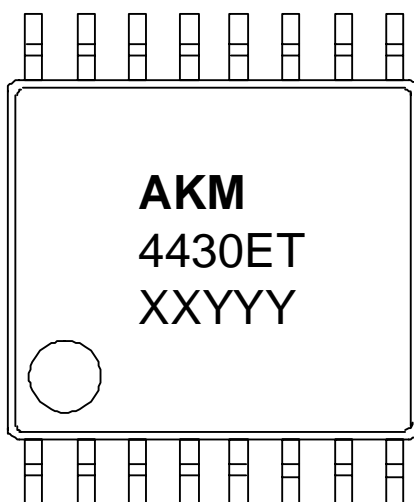

- 1) Pin #1 indication
- 2) Date Code : XXYYY (5 digits)
 XX: Lot#
 YYY: Date Code
- 3) Marketing Code : 4430ET
- 4) Asahi Kasei Logo

REVISION HISTORY

Date (YY/MM/DD)	Revision	Reason	Page	Contents
10/05/31	00	First Edition		
11/03/01	01	Error Correction	15	1. Grounding and Power Supply Decoupling The description was changed.

IMPORTANT NOTICE

- These products and their specifications are subject to change without notice.
When you consider any use or application of these products, please make inquiries the sales office of Asahi Kasei Microdevices Corporation (AKM) or authorized distributors as to current status of the products.
- Descriptions of external circuits, application circuits, software and other related information contained in this document are provided only to illustrate the operation and application examples of the semiconductor products. You are fully responsible for the incorporation of these external circuits, application circuits, software and other related information in the design of your equipments. AKM assumes no responsibility for any losses incurred by you or third parties arising from the use of these information herein. AKM assumes no liability for infringement of any patent, intellectual property, or other rights in the application or use of such information contained herein.
- Any export of these products, or devices or systems containing them, may require an export license or other official approval under the law and regulations of the country of export pertaining to customs and tariffs, currency exchange, or strategic materials.
- AKM products are neither intended nor authorized for use as critical components^{Note1)} in any safety, life support, or other hazard related device or system^{Note2)}, and AKM assumes no responsibility for such use, except for the use approved with the express written consent by Representative Director of AKM. As used here:
 - Note1) A critical component is one whose failure to function or perform may reasonably be expected to result, whether directly or indirectly, in the loss of the safety or effectiveness of the device or system containing it, and which must therefore meet very high standards of performance and reliability.
 - Note2) A hazard related device or system is one designed or intended for life support or maintenance of safety or for applications in medicine, aerospace, nuclear energy, or other fields, in which its failure to function or perform may reasonably be expected to result in loss of life or in significant injury or damage to person or property.
- It is the responsibility of the buyer or distributor of AKM products, who distributes, disposes of, or otherwise places the product with a third party, to notify such third party in advance of the above content and conditions, and the buyer or distributor agrees to assume any and all responsibility and liability for and hold AKM harmless from any and all claims arising from the use of said product in the absence of such notification.