

Service Manual

PIONEER
The Art of Entertainment

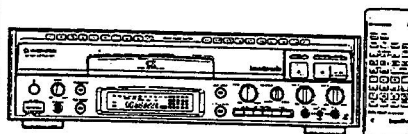

• CLD-V740/KU

ORDER NO.
ARP2803

CD CDV LD PLAYER

CLD-V740 CLD-1720K

CLD-V740 AND CLD-1720K HAVE THE FOLLOWING :

Type	Model		Power Requirement	Remarks
	CLD-V740	CLD-1720K		
KU	○	—	AC120V only	
KC	○	—	AC120V only	
SD	—	○	AC110V, 120-127V, 220V, 240V (switchable)	

- This manual is applicable to the following : CLD-V740 / KU and KC ; CLD-1720K / SD.
- For the following : CLD-V740 / KC; CLD-1720K / SD, refer to page 55.
- For the disassembly and mechanism descriptions, refer to the service manual ARP2528 for CLD-S201 and CLD-S250.

CONTENTS

1. SAFETY INFORMATION.....	2	6. FL INFORMATION.....	53
2. EXPLODED VIEWS, PACKING AND PARTS LIST.....	3	7. IC INFORMATION.....	54
3. SCHEMATIC AND PCB CONNECTION DIAGRAMS.....	16	8. FOR CLD-V740/KC AND CLD-1720K/SD.....	55
4. PCB PARTS LIST.....	41	9. CONNECTIONS.....	56
5. ADJUSTMENTS.....	46	10. PANEL FACILITIES.....	58
		11. SPECIFICATIONS.....	60

PIONEER ELECTRONIC CORPORATION 4-1, Meguro 1-Chome, Meguro-ku, Tokyo 153, Japan
PIONEER ELECTRONICS SERVICE INC. P.O. Box 1760, Long Beach, California 90801 U.S.A.
PIONEER ELECTRONICS OF CANADA, INC. 300 Allstate Parkway Markham, Ontario L3R 0P2 Canada
PIONEER ELECTRONIC [EUROPE] N.V. Haven 1087 Keetberglaan 1, 9120 Melsele, Belgium
PIONEER ELECTRONICS AUSTRALIA PTY. LTD. 178-184 Boundary Road, Braeside, Victoria 3195, Australia TEL: [03] 580-9911
 © PIONEER ELECTRONIC CORPORATION 1993

I FO JUNE 1993 Printed in Japan

1. SAFETY INFORMATION



This service manual is intended for qualified service technicians; it is not meant for the casual do-it-yourselfer. Qualified technicians have the necessary test equipment and tools, and have been trained to properly and safely repair complex products such as those covered by this manual. Improperly performed repairs can adversely affect the safety and reliability of the product and may void the warranty. If you are not qualified to perform the repair of this product properly and safely, you should not risk trying to do so and refer the repair to a qualified service technician.

WARNING

Lead in solder used in this product is listed by the California Health and Welfare agency as a known reproductive toxicant which may cause birth defects or other reproductive harm (California Health & Safety Code, Section 25249.5). When servicing or handling circuit boards and other components which contain lead in solder, avoid unprotected skin contact with the solder. Also, when soldering do not inhale any smoke or fumes produced.



NOTICE

(FOR CANADIAN MODEL ONLY)

Fuse symbols  (fast operating fuse) and/or  (slow operating fuse) on PCB indicate that replacement parts must be of identical designation.

REMARQUE

(POUR MODÈLE CANADIEN SEULEMENT)

Les symboles de fusible  (fusible de type rapide) et/ou  (fusible de type lent) sur CCI indiquent que les pièces de remplacement doivent avoir la même désignation.

(FOR USA MODEL ONLY)

1. SAFETY PRECAUTIONS

The following check should be performed for the continued protection of the customer and service technician.

LEAKAGE CURRENT CHECK

Measure leakage current to a known earth ground (water pipe, conduit, etc.) by connecting a leakage current tester such as Simpson Model 229-2 or equivalent between the earth ground and all exposed metal parts of the appliance (input/output terminals, screwheads, metal overlays, control shaft, etc.). Plug the AC line cord of the appliance directly into a 120V AC 60Hz outlet and turn the AC power switch on. Any current measured must not exceed 0.5mA.

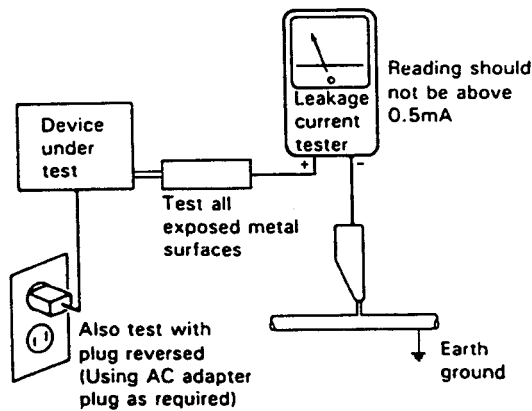

AC Leakage Test

ANY MEASUREMENTS NOT WITHIN THE LIMITS OUTLINED ABOVE ARE INDICATIVE OF A POTENTIAL SHOCK HAZARD AND MUST BE CORRECTED BEFORE RETURNING THE APPLIANCE TO THE CUSTOMER.

2. PRODUCT SAFETY NOTICE

Many electrical and mechanical parts in the appliance have special safety related characteristics. These are often not evident from visual inspection nor the protection afforded by them necessarily can be obtained by using replacement components rated for voltage, wattage, etc. Replacement parts which have these special safety characteristics are identified in this Service Manual.

Electrical components having such features are identified by marking with a Δ on the schematics and on the parts list in this Service Manual. The use of a substitute replacement component which does not have the same safety characteristics as the PIONEER recommended replacement one, shown in the parts list in this Service Manual, may create shock, fire, or other hazards.

Product Safety is continuously under review and new instructions are issued from time to time. For the latest information, always consult the current PIONEER Service Manual. A subscription to, or additional copies of, PIONEER Service Manual may be obtained at a nominal charge from PIONEER.

2. EXPLODED VIEWS, PACKING AND PARTS LIST

NOTES:

- Parts marked by "NSP" are generally unavailable because they are not in our Master Spare Parts List.
- The Δ mark found on some component parts indicates the importance of the safety factor of the part. Therefore, when replacing, be sure to use parts of identical designation.
- Parts marked by "⊙" are not always kept in stock. Their delivery time may be longer than usual or they may be unavailable.

(1) EXTERIOR SECTION

Parts List

Mark	No.	Description	Part No.	Mark	No.	Description	Part No.
	1	Guide plate (L)	VNE1805		16	Tray panel assembly	VXA1970
	2	Guide plate (R)	VNE1806		17	Door holder	VNE1812
	3	Lock plate spring	VBH1188		18	Door shaft	VLL1441
	4	Lock plate	VNL1513	NSP	19	65 label	ORW1069
	5	CD tray	VNK1992	NSP	20	Spacer	VEC1585
	6	Tray assembly - S	VXX1885		21	Tray rubber	VEB1091
NSP	7	LD tray	VNK1991	NSP	22	PCB holder	VNE1830
	8	Disc pad (Large)	VEC1191		23	Screw	BPZ30P060FCU
	9	Disc pad (C)	VEC1380		24	Screw	VBA1034
NSP	10	Carry label	VRW1289		25	Screw	BBZ30P080FCC
	11	Bonnet S	VXX1898		26	Screw	BCZ40P060FZK
	12	Door spring	VBH1202		27	Screw	IPZ20P050FMC
	13	CD door assembly - S	VXX1779		28	Screw	VBA1032
	14	Cushion	VEC1578	NSP	29	Damp cushion	VEC1110
NSP	15	CD door	VNK2075	NSP	30	Cushion	VEC1618
					31	Screw	BPZ30P080FCU
					32	Karaoke badge	VAM1034

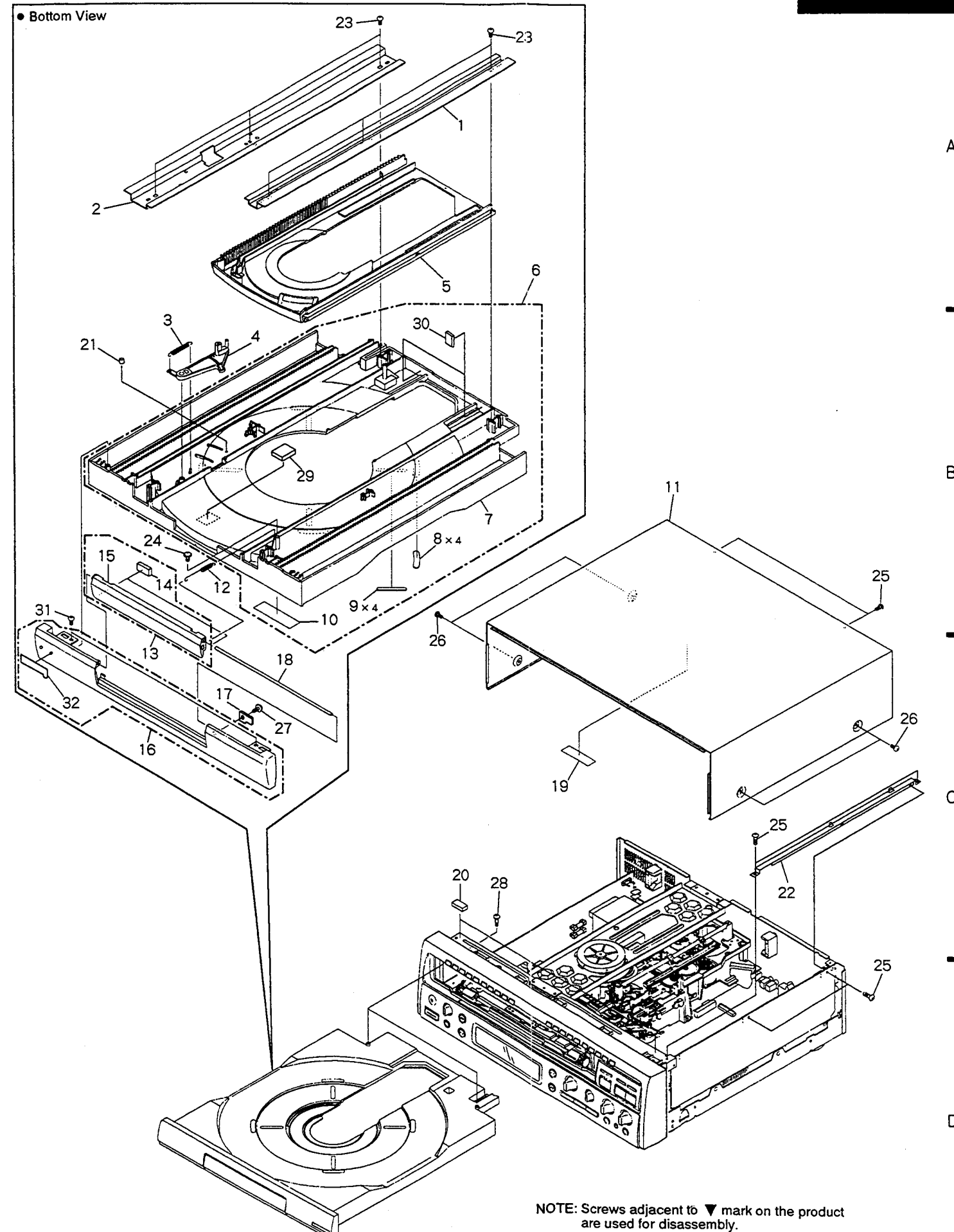

NOTE: Screws adjacent to ▼ mark on the product are used for disassembly.

(2) TOP VIEW SECTION

Parts List

Mark	No.	Description	Part No.
	1	Clamper holder	VNL1514
	2	Rubber mat	VEB1114
	3	Thrust holder	VNL1289
	4	Clamper head	VNL1516
	5	Clamper	VNL1515
	6	Clamper spring	VBH1192
	7	Clamper arm	VNE1804
	8	Stabilizer	VNE1807
	9	Rack assembly	VWT1103
	10	Carriage shaft	VLL1434
NSP	11	Side stay (R)	VNE1810
NSP	12	Front angle	VNE1808
	13	Screw	CPZ20P050FMC
	14	Screw	BBZ30P080FCC
	15	Screw	IBZ30P060FCC
	16	Screw	IPZ30P060FMC
	17	Screw	PCZ30P060FMC
NSP	18	Earth plate	VNE1518
NSP	19	Mechanism assembly	VWT1081
	20	Flexible cable	VDA1409
	21	Screw	BBZ30P060FMC

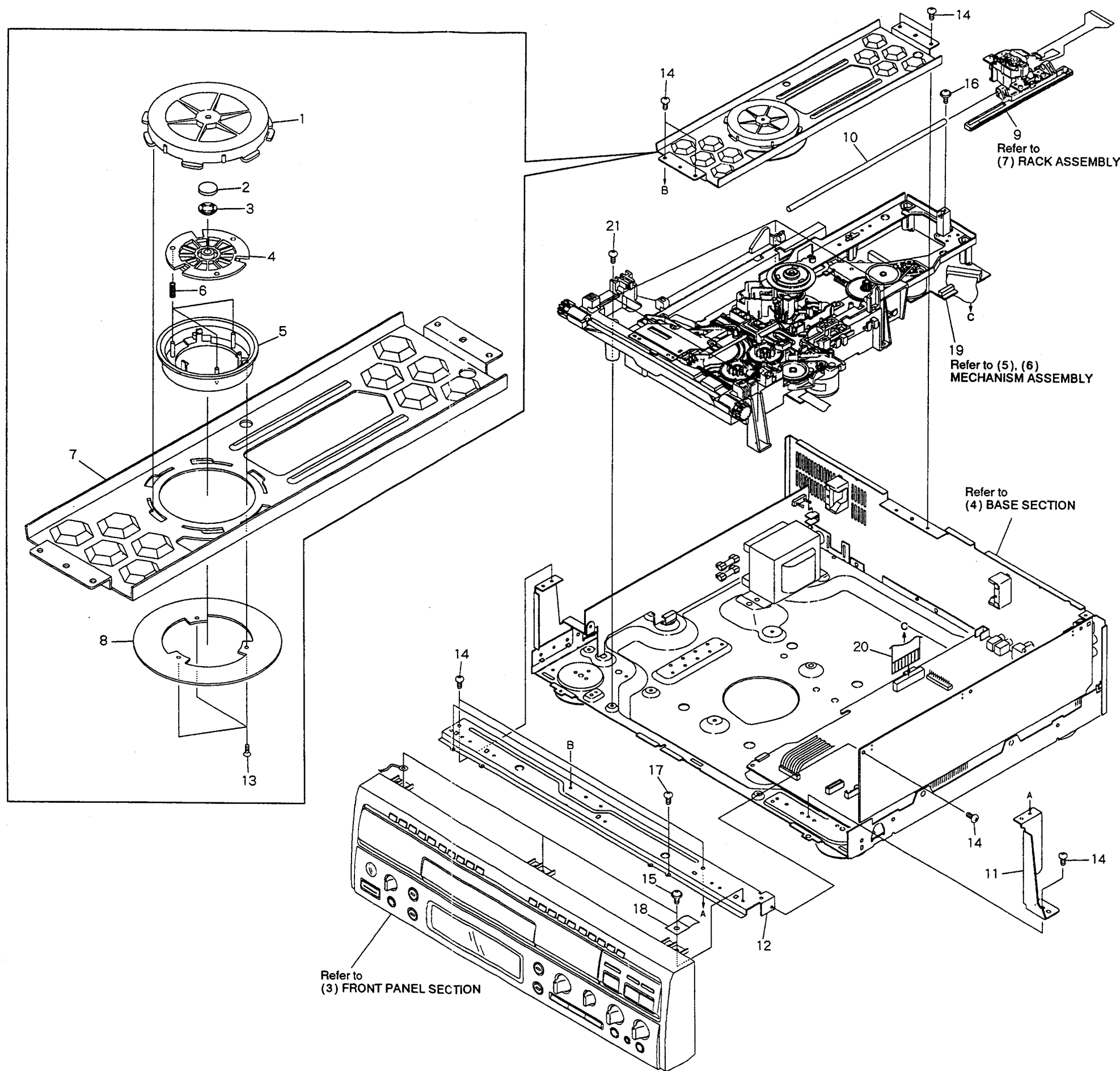

A

B

C

D

(3) FRONT PANEL SECTION

Parts List

Mark No.	Description	Part No.	Mark No.	Description	Part No.	
1	Snap plate	VNE1102	16	L key (R) assembly	VXA1972	
2	Jack holder (L)	VNE1818	NSP	17	FLKB assembly	VWG1450
3	Volume holder	VNE1823	NSP	18	IRKB assembly	VWG1435
4	FL filter	VNK1659	NSP	19	FDKB assembly	VWG1436
5	PW button	VNK2002	NSP	20	SDKB assembly	VWG1437
6	FL lens	VNK2070	NSP	21	MIJB assembly	VWV1303
7	Key con. button	VNK2278	NSP	22	HEPB assembly	VWV1304
8	VR knob (S)	VNK2221	23	Screw	BPZ26P060FCU	
9	VR knob (L)	VNK2220	NSP	24	Cord clamper	Z09-061
10	Main key assembly	VXA1975	25	Cushion	VEC1621	
11	Ten key (L)	VNK2279				
12	Ten key (R)	VNK2280				
13	Sub panel	VNK2276				
14	L key (L) assembly	VXA1971				
15	Front panel assembly	VXA1967				

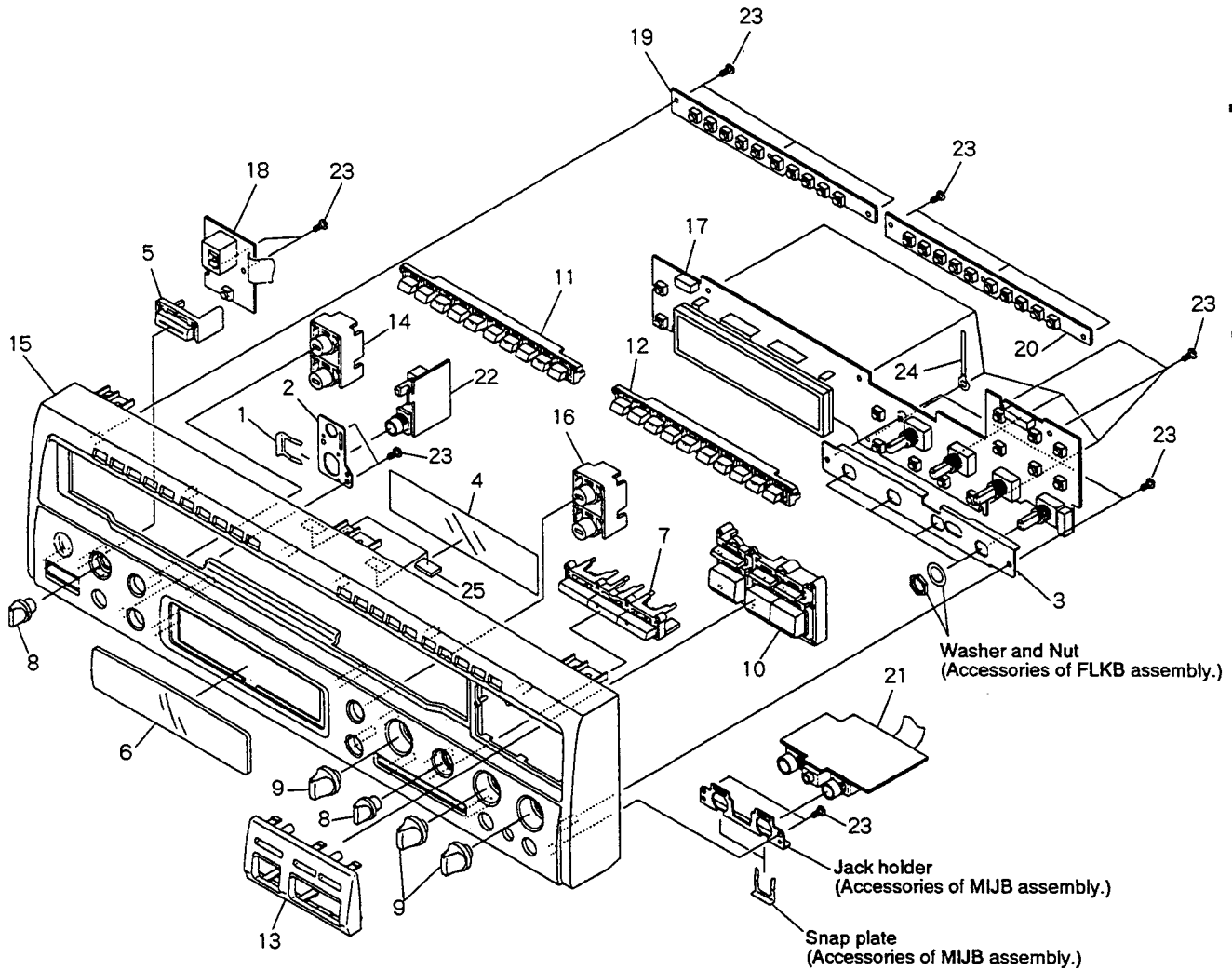

(4) BASE SECTION

Parts List

Mark	No.	Description	Part No.	Mark	No.	Description	Part No.
NSP	1	MAIN assembly	VWX1191	△	11	Power transformer	VTT1119
NSP	2	AUDIO assembly	VWV1323	△	12	Fuse (FU1, FU2) (3A)	VEK1021
⊙	3	SYPS assembly	VWR1160	NSP	13	P. plate holder	PNY-405
	4	Tray stopper	VNL1519	NSP	14	Side stay (L)	VNE1809
△	5	AC power cord	PDG1015	NSP	15	Cord clamber	Z09-061
△	6	Strain relief	CM-22C		16	Insulator	PNW1912
NSP	7	Rear panel	VNA1337	NSP	17	Base chassis	VNA1255
	8	PCB cushion	VEC1573		18	Insulator assembly	VXA1881
NSP	9	Support cushion	VEC1601		19	Screw	BBZ30P080FCC
NSP	10	PCB hinge	VEC1174		20	Screw	BBZ30P040FMC
					21	Screw	BCZ40P060FZK
					22	Screw	BCZ30P080FMC
				△	23	Fuse (FU3)(1A)	VEK1014
					24	
				NSP	25	Cord clamber	Z09-060
					26	Screw	BCZ30P060FCC
				NSP	27	Heat sink	VNE1854
				NSP	28	Earth plate	VNE1859

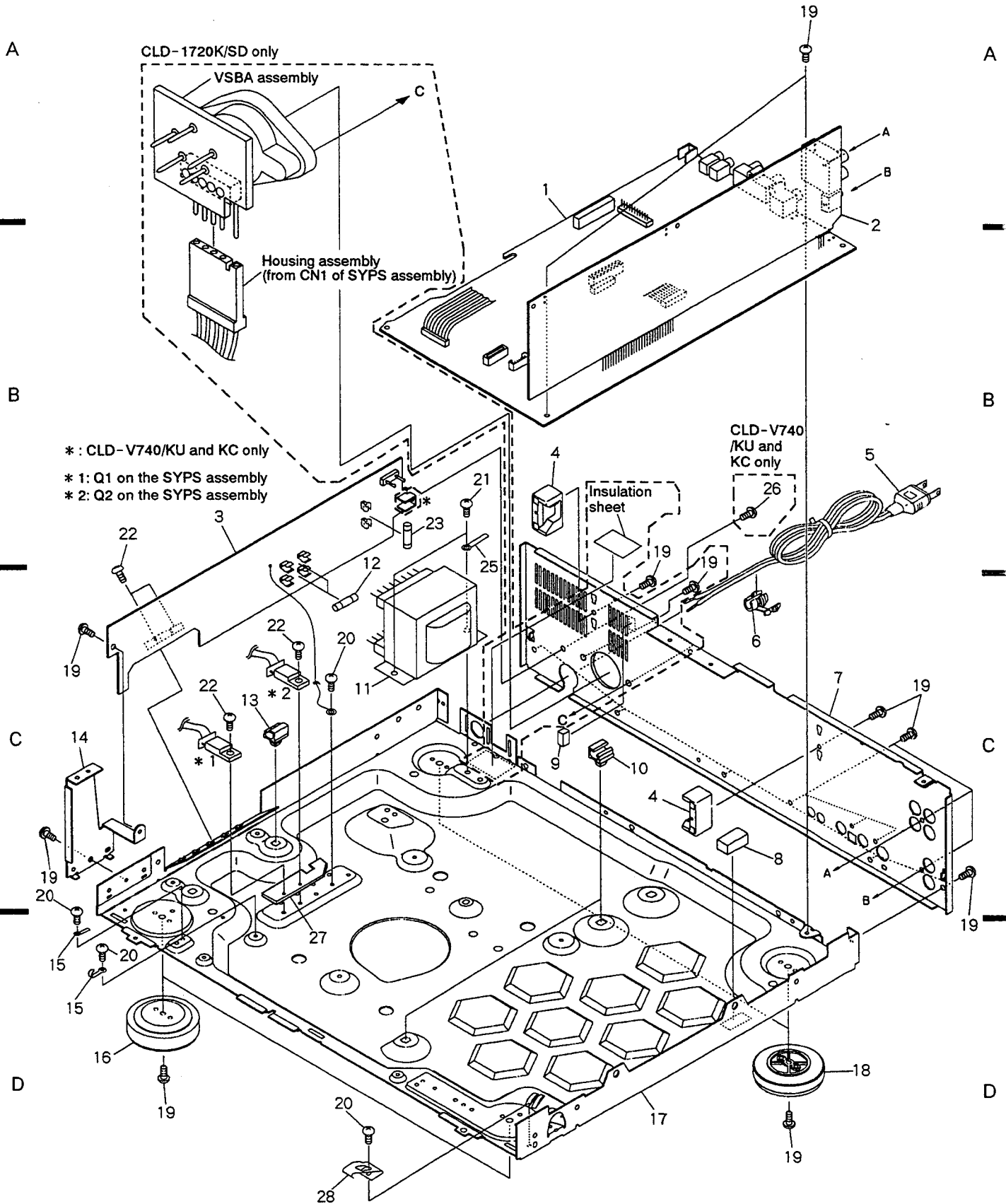

(5) MECHANISM ASSEMBLY (LOWER SECTION)

Parts List

<u>Mark</u>	<u>No.</u>	<u>Description</u>	<u>Part No.</u>	<u>Mark</u>	<u>No.</u>	<u>Description</u>	<u>Part No.</u>
	1	Mechanism base	VNK1990		14	L-SW lever	VNL1504
	2			15	C-SW lever	VNL1505
	3	Clamp cam	VNL1500		16	R-SW lever	VNL1506
	4	Shaft holder	VNE1817	NSP	17	LOSB assembly	VWG1307
	5	Cam plate	VNL1511		18	Synchro gear assembly	VXA1822
	6	CAS spring	VBH1190		19	Roller	VNL1042
	7	Cam gear	VNL1507	NSP	20	LOMB assembly	VWG1308
	8	CD plate	VNL1512		21	Loading motor assembly	VXX1712
	9	CDP spring	VBH1191		22	Slider motor	VXM1033
	10	Rubber belt	VEB1184	NSP	23	Motor pulley	PNW1643
	11	Gear pulley	VNL1510		24	Screw	Z39-019
	12	Twin gear	VNL1508		25	Screw	BMZ26P040FMC
	13	Center gear	VNL1509				

Refer to
(6) MECHANISM ASSEMBLY (UPPER SECTION)

A

A

B

B

C

C

D

D

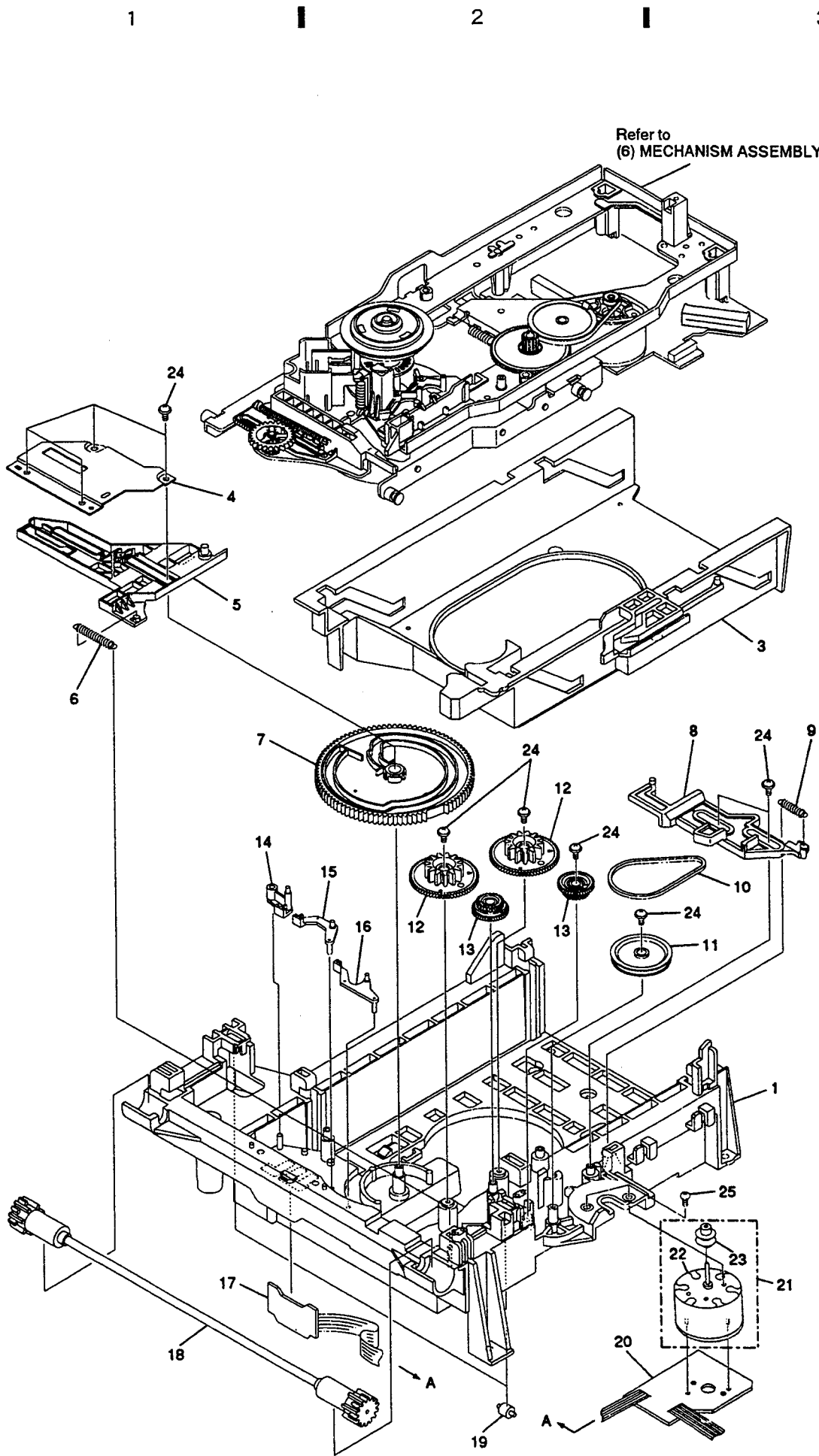

(6) MECHANISM ASSEMBLY (UPPER SECTION)

Parts List

<u>Mark</u>	<u>No.</u>	<u>Description</u>	<u>Part No.</u>	<u>Mark</u>	<u>No.</u>	<u>Description</u>	<u>Part No.</u>
	1	CA belt	VEB1077		16	Y gear	VNL1501
	2	CA pulley (2)	VNL1496		17	Tilt cam spring	VBH1189
	3	CA gear (3)	VNL1497		18	Tilt cam	VNL1502
	4	Tilt base	VNL1499		19	Spindle motor assembly	VXA2010
	5	CA-SW lever	VNL1498		20	Centering hub	VNL1174
NSP	6	CAMB assembly	VWG1306		21	Centering spring	VBH1083
	7	CRG motor assembly	VXX1261	NSP	22	Rubber sheet	VEB1103
NSP	8	Slider motor	VXM1033	NSP	23	Turn table assembly	VXA1283
	9	CA pulley (1)	VNL1197	NSP	24	Oil stopper	VBF1002
NSP	10	PKSB assembly	VWG1305	NSP	25	Spindle motor	VXM1055
	11	Radial spring	VBH1201		26	Motor base	VNE1803
	12	Thrust spring	VBH1200		27	Screw	BMZ26P040FMC
	13	Tilt tension spring	VBH1187		28	Screw	ABZ30P300FMC
NSP	14	FG assembly	VWG1304		29	Screw	PMA30P050FMC
	15	FG base	VNL1503		30	Washer	WT26D060D025

C

CLD - V740

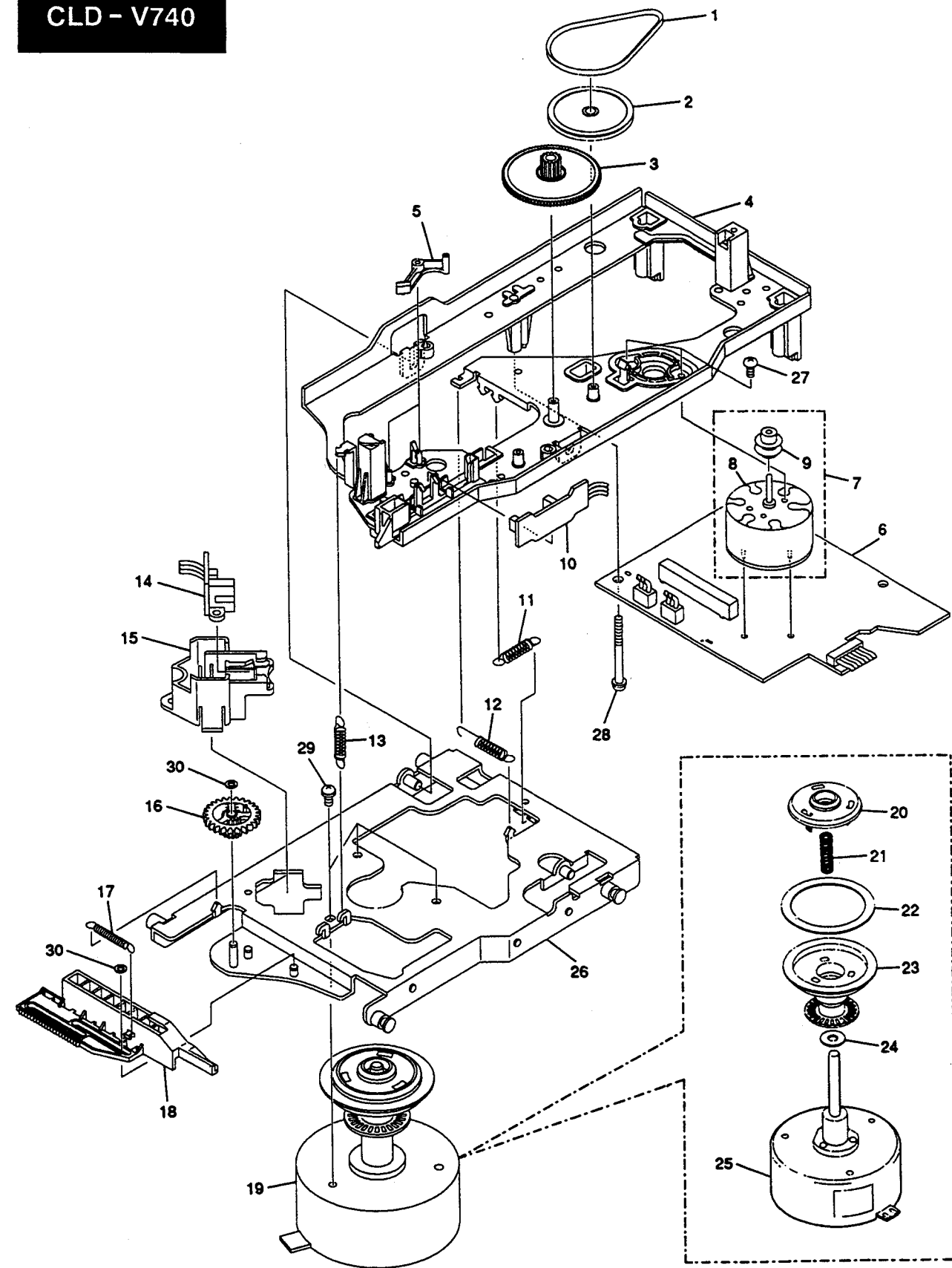

(7) RACK ASSEMBLY

Parts List

Mark	No.	Description	Part No.
NSP	1	Sensor stay	VBK1036
NSP	2	Tilt sensor	SG-302
NSP	3	Pickup assembly	VWY1030
	4	Rack	VNL1495
	5	Tan. base	VNL1494
	6	Screw	PBB26P080FMC
	7	Screw	PMA20P060FMC
	8	Screw	PMA20P080FMC
	9	Screw	PMH20P040FMC
	10	Screw	SMZ20H120FZK

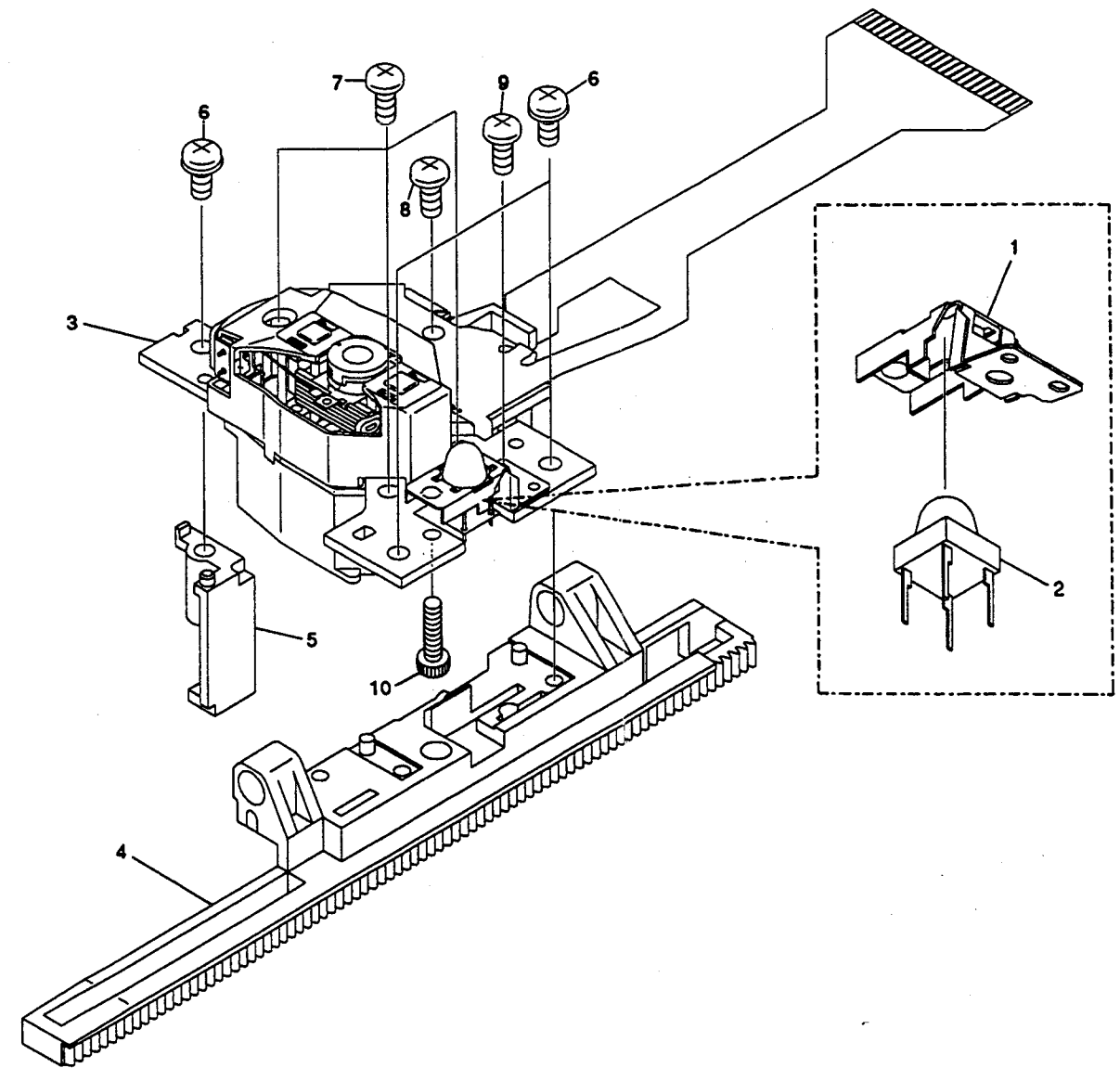

1

2

3

4

5

6

(7) RACK ASSEMBLY

Parts List

Mark No.	Description	Part No.
NSP 1	Sensor stay	VBK1036
NSP 2	Tilt sensor	SG-302
NSP 3	Pickup assembly	VWY1030
4	Rack	VNL1495
5	Tan. base	VNL1494
6	Screw	PBB26P080FMC
7	Screw	PMA20P060FMC
8	Screw	PMA20P080FMC
9	Screw	PMH20P040FMC
10	Screw	SMZ20H120FZK

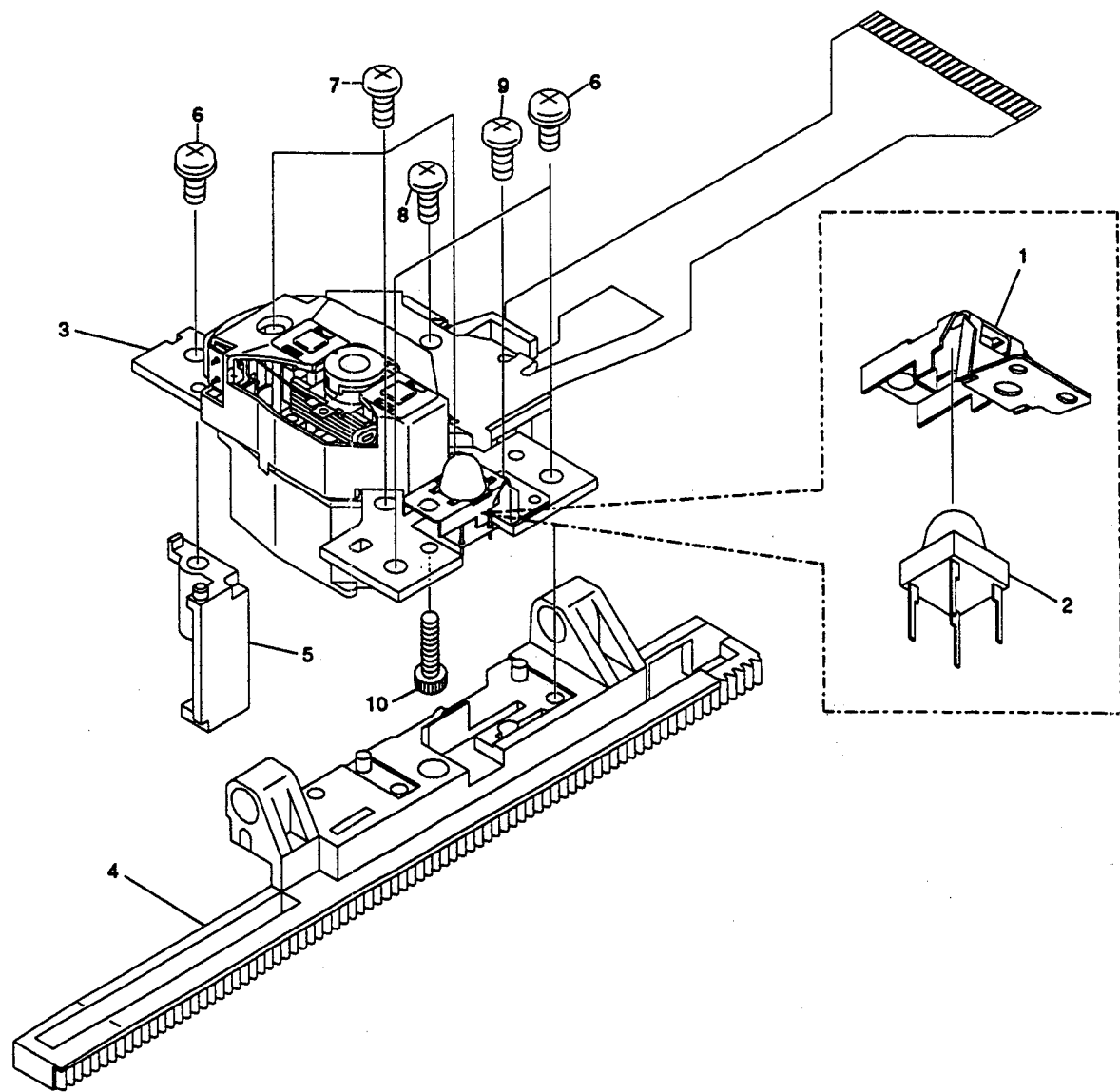

(8) PACKING

Parts List

Mark No.	Description	Part No.	Mark No.	Description	Part No.
NSP 1	Warranty card	ARY1044	NSP 10	Caution card	VRR1009
NSP 2	Cord with plug (AUDIO)	VDE-055	NSP 11	Remote control unit (CU-CLD046)	VXX1603
NSP 3	Cord with plug (VIDEO)	VDE-056	NSP 12	Battery cover	VNK1293
NSP 4	Battery (R03, AAA)	VEM-022	NSP 13	Vinyl bag	Z21-029
NSP 5	Vinyl bag	VHL-014	14	Pad (F)	VHA1112
6	Operating instructions (English)	VRB1089	15	Pad (R)	VHA1113
7	Packing case	VHG1279			
NSP 8	Mirror mat	VHL1006			
NSP 9	Caution card (UC)	VRM1026			

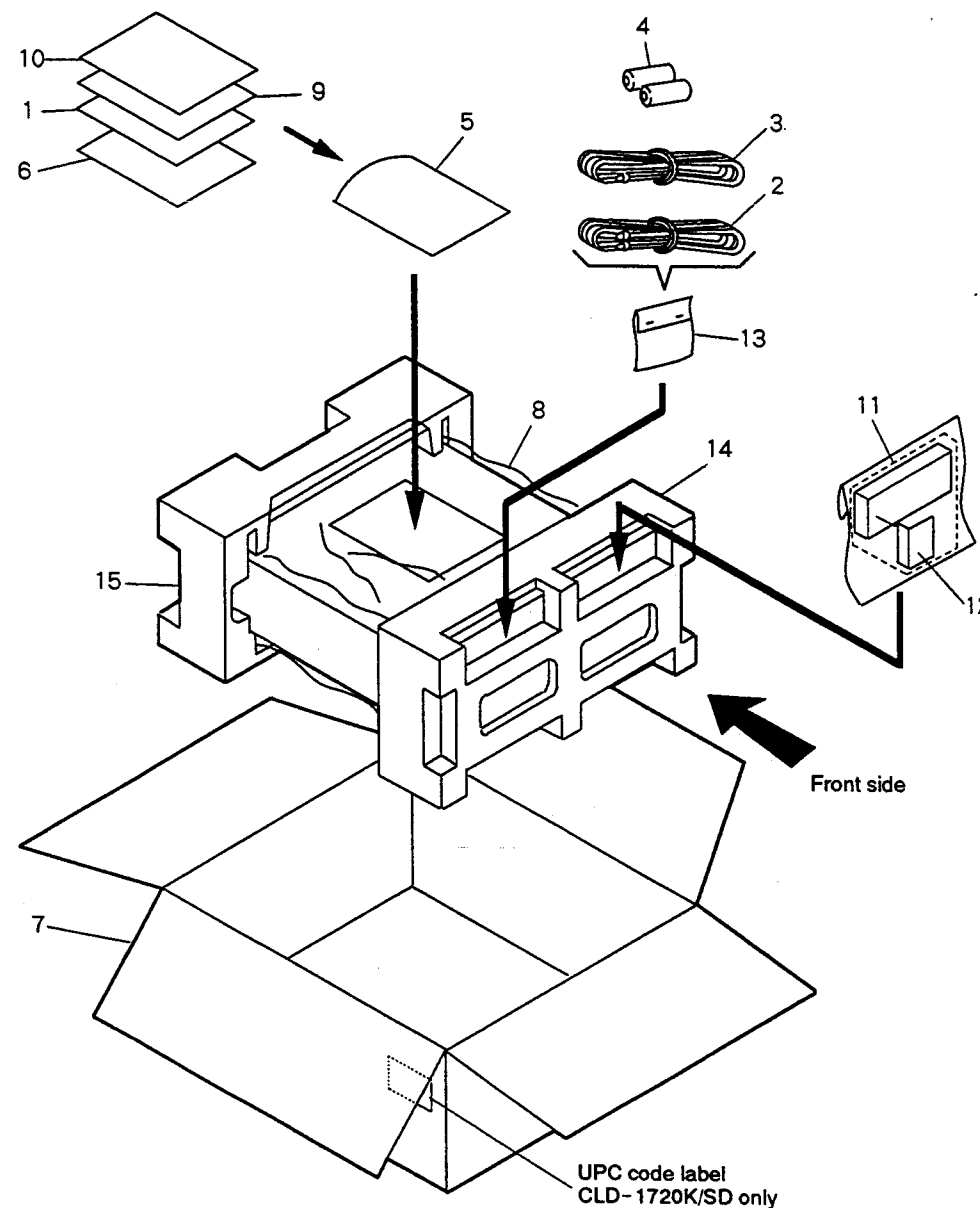

A

B

C

D

E

F

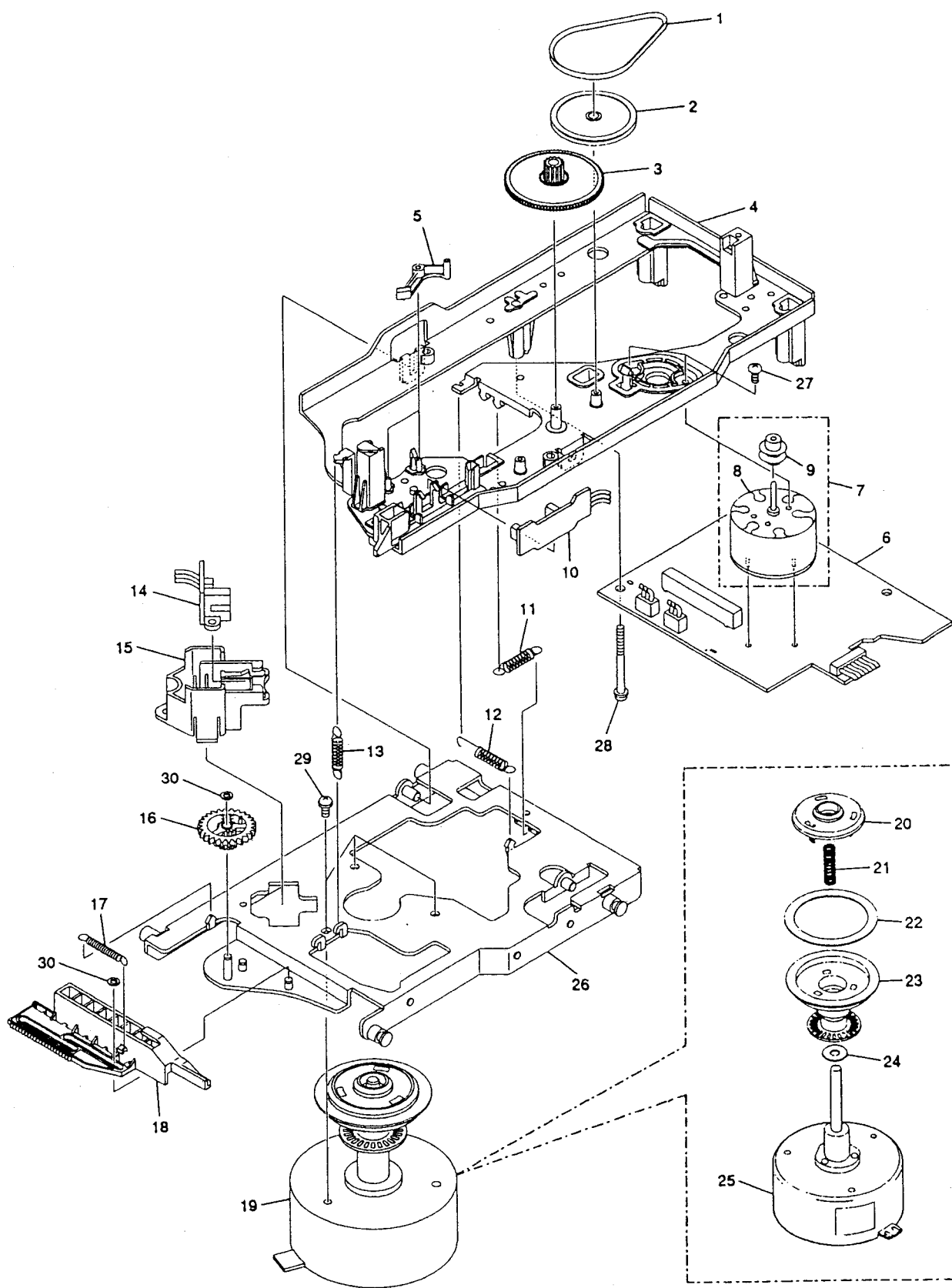

(7) RACK ASSEMBLY

Parts List

Mark	No.	Description	Part No.
NSP	1	Sensor stay	VBK1036
NSP	2	Tilt sensor	SG-302
NSP	3	Pickup assembly	VWY1030
	4	Rack	VNL1495
	5	Tan. base	VNL1494
	6	Screw	PBB26P0
	7	Screw	PMA20PC
	8	Screw	PMA20PC
	9	Screw	PMH20PC
	10	Screw	SMZ20H1

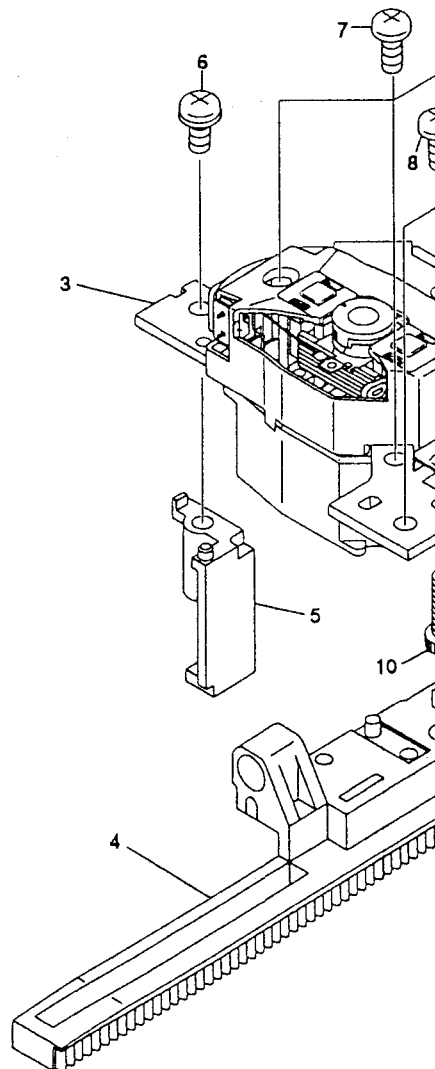

1

2

3

4

(7) RACK ASSEMBLY

Parts List

Mark	No.	Description	Part No.
NSP	1	Sensor stay	VBK1036
NSP	2	Tilt sensor	SG-302
NSP	3	Pickup assembly	VWY1030
	4	Rack	VNL1495
	5	Tan. base	VNL1494
	6	Screw	PBB26P080FMC
	7	Screw	PMA20P060FMC
	8	Screw	PMA20P080FMC
	9	Screw	PMH20P040FMC
	10	Screw	SMZ20H120FZK

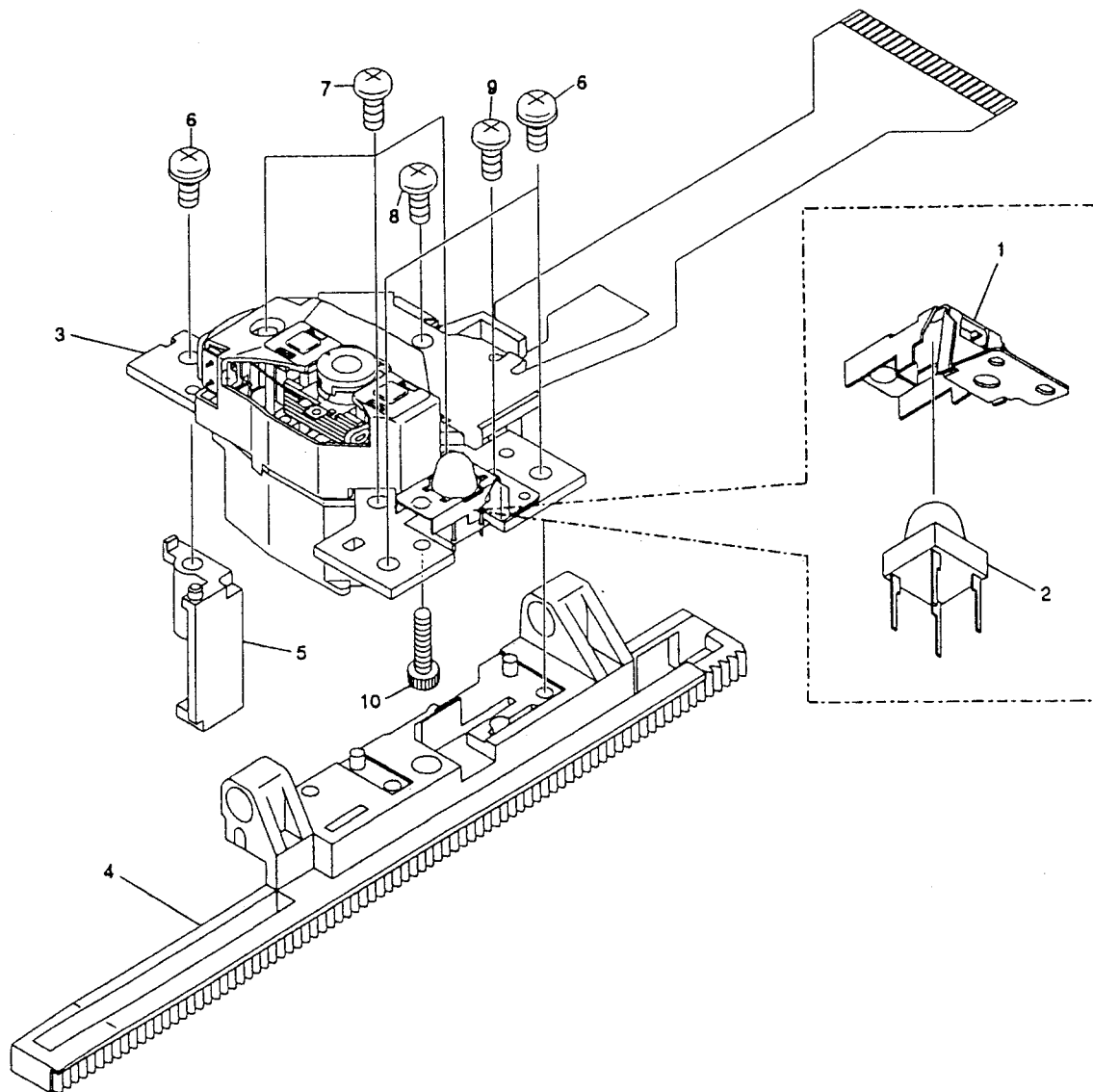

(8) PACKING

Parts List

Mark	No.	Description	Part No.
NSP	1	Warranty card	ARY1044
	2	Cord with plug (AUDIO)	VDE-055
	3	Cord with plug (VIDEO)	VDE-056
NSP	4	Battery (R03, AAA)	VEM-022
NSP	5	Vinyl bag	VHL-014
	6	Operating instructions (English)	VRB1089
	7	Packing case	VHG1279
	8	Mirror mat	VHL1006
NSP	9	Caution card (UC)	VRM1026

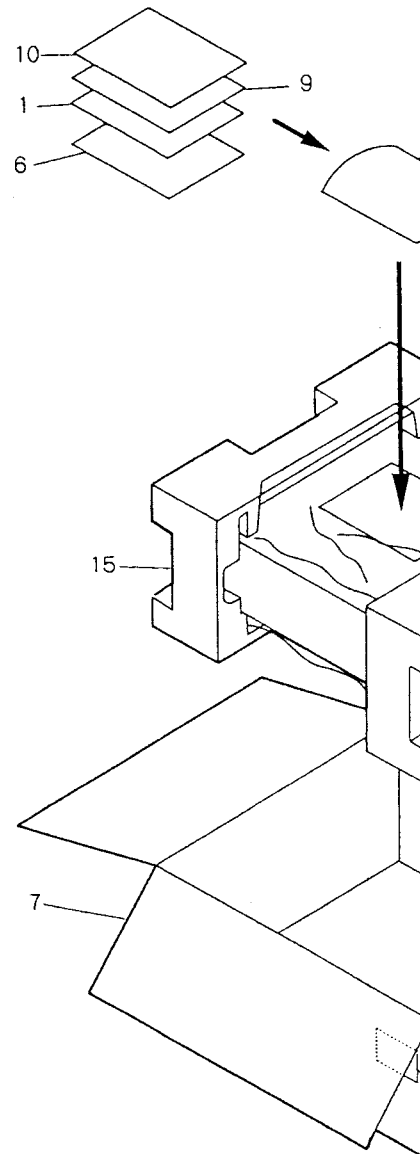

A

B

C

D

E

F

(8) PACKING

Parts List

Mark No.	Description	Part No.	Mark No.	Description	Part No.
NSP 1	Warranty card	ARY1044	NSP 10	Caution card	VRR1009
2	Cord with plug (AUDIO)	VDE-055	11	Remote control unit (CU-CLD046)	VXX1603
3	Cord with plug (VIDEO)	VDE-056	12	Battery cover	VNK1293
NSP 4	Battery (R03, AAA)	VEM-022	NSP 13	Vinyl bag	Z21-029
NSP 5	Vinyl bag	VHL-014	14	Pad (F)	VHA1112
6	Operating instructions (English)	VRB1089	15	Pad (R)	VHA1113
7	Packing case	VHG1279			
8	Mirror mat	VHL1006			
NSP 9	Caution card (UC)	VRM1026			

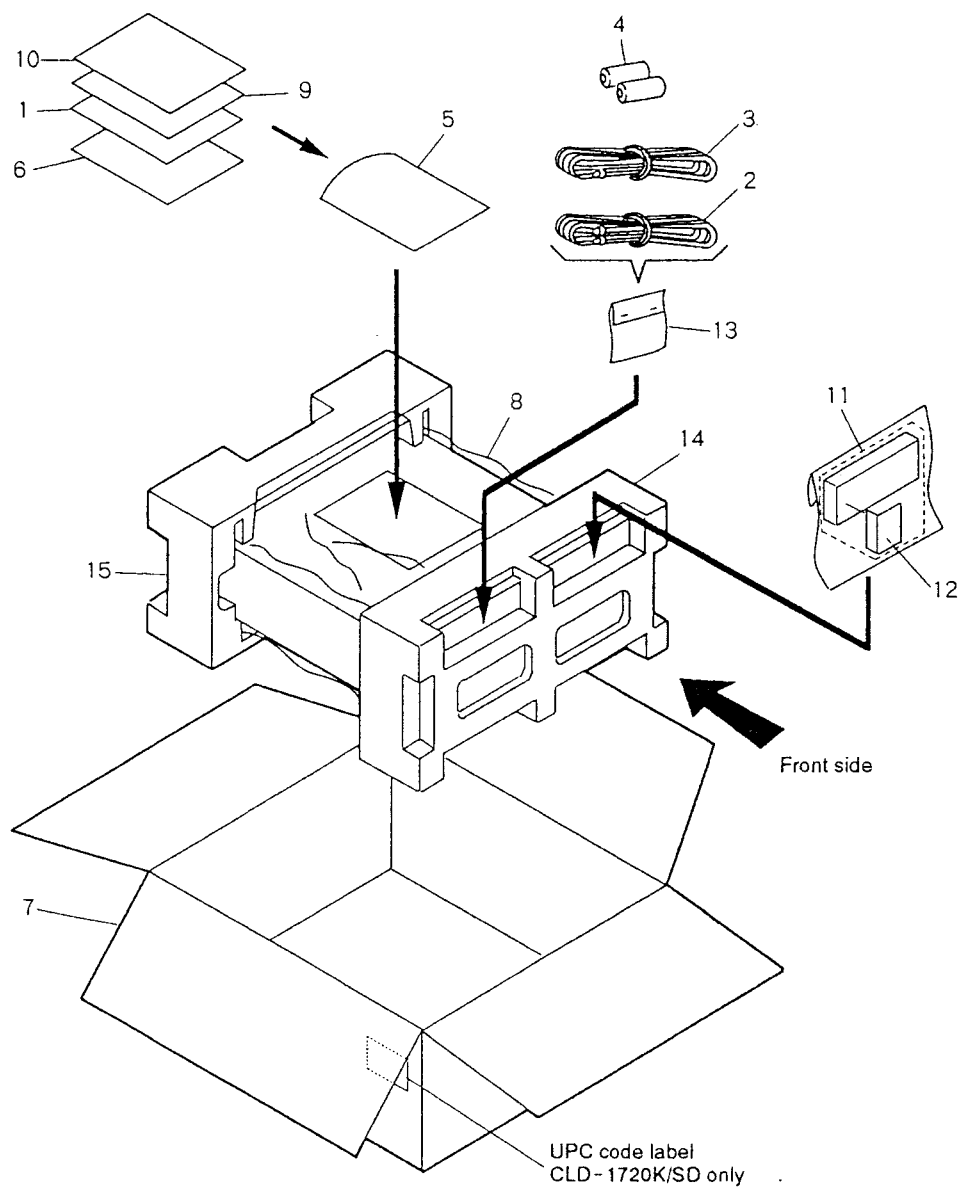
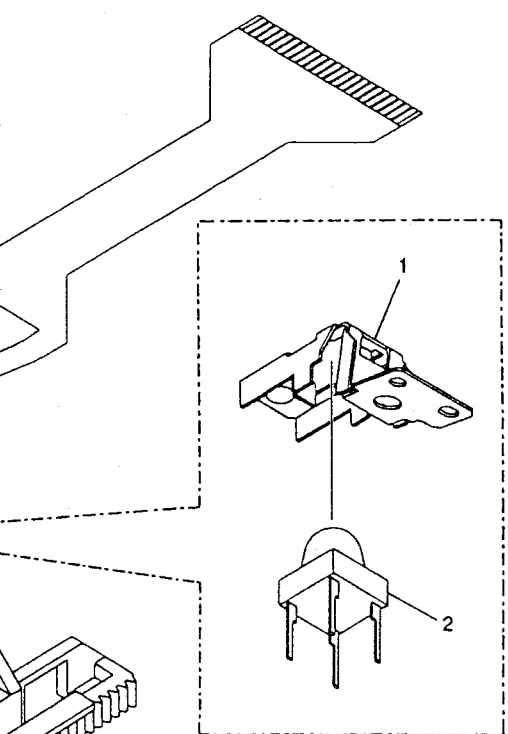

3. SCHEMATIC AND PCB CONNECTION DIAGRAMS

3.1 IRKB, FDKB, SDKB, FLKB, MIJB, HEPB, SYPS, VSBA, FG, PKSB, CAMB, LOSB, LOMB AND PICKUP ASSEMBLIES

A

B

C

D

E

F

FRPB ASSEMBLY (VWM1402)

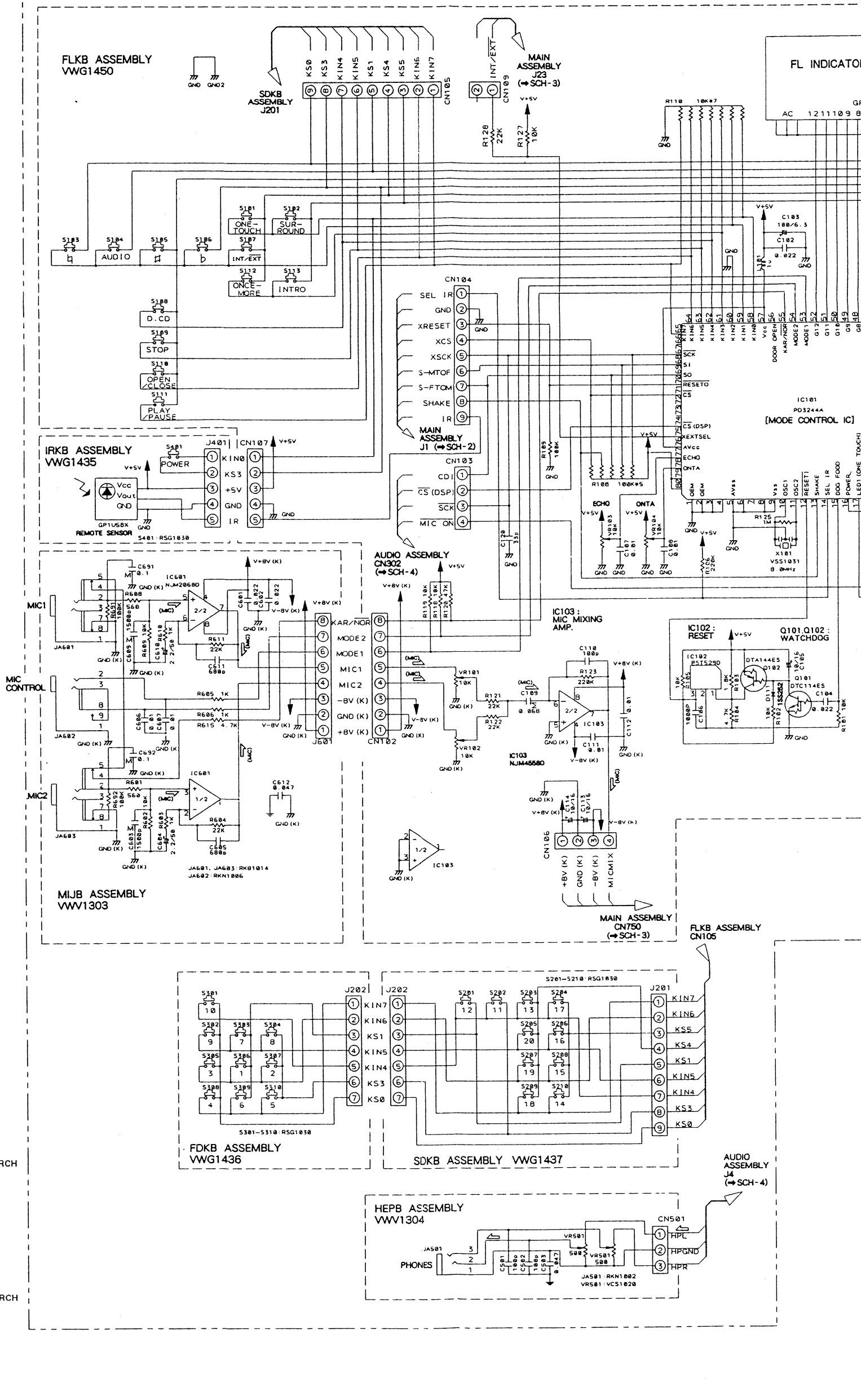

NOTE FOR SCHEMATIC DIAGRAMS (Type 4A)

- When ordering service parts, be sure to refer to "PARTS LIST OF EXPLODED VIEWS" or "PCB PARTS LIST".
- Since these are basic circuits, some parts of them or the values of some components may be changed for improvement.
- RESISTORS:**
Unit: k Ω , M Ω , or Ω unless otherwise noted.
Rated power: 1/4W, 1/8W, 1/10W unless otherwise noted.
Tolerance: (F): $\pm 1\%$, (G): $\pm 2\%$, (K): $\pm 10\%$, (M): $\pm 20\%$ or $\pm 5\%$ unless otherwise noted.
- CAPACITORS:**
Unit: p μ F or μ F unless otherwise noted.
Ratings: capacitor (μ F) / voltage (V) unless otherwise noted.
Rated voltage: 50V except for electrolytic capacitors.
- COILS:**
Unit: m μ H or μ H unless otherwise noted.
- VOLTAGE AND CURRENT:**
DC or \pm V:
DC voltage (V) in PLAY mode unless otherwise noted.
mA or \pm mA:
DC current in PLAY mode unless otherwise noted.
Value in () is DC current in STOP mode.
- OTHERS:**
● or ○ : Adjusting point.
● : Measurement point.
● The Δ mark found on some component parts indicates the importance of the safety factor of the parts. Therefore, when replacing, be sure to use parts of identical designation.
- SCH - □ ON THE SCHEMATIC DIAGRAM:**
● SCH-□ Indicates the drawing number of the schematic diagram. (SCH stands for schematic diagram.)
- SWITCHES** (Underline indicates switch position):
VSBA ASSEMBLY
VOLTAGE SELECTOR : AC 110V/120 - 127V/220V/240V

PKSB ASSEMBLY	FDKB ASSEMBLY	
S4 :PARK OUT	S301 :10	
S5 :PARK IN	S302 :9	
LOS B ASSEMBLY	S303 :7	
S1 :TILT LOADING1	S304 :8	
S2 :TILT LOADING2	S305 :3	
S3 :TILT LOADING3	S306 :1	
AUDIO ASSEMBLY	S307 :2	
S301 :ATTENUATOR	S308 :4	
FLKB ASSEMBLY	S309 :6	
S101 :ONE - TOUCH KARAOKE	S310 :5	
S102 :SURROUND	S311 :12	
S103 :4 KEY CONTROL	S201 :12	
S104 :AUDIO MODE	S202 :11	
S105 :# KEY CONTROL	S203 :13	
S106 :b KEY CONTROL	S204 :17	
S107 :AUX INPUT	S205 :20	
S108 :DIRECT CD	S206 :16	
S109 :STOP (■)	S207 :19	
S110 :OPEN/CLOSE (▲)	S208 :15	
S111 :PLAY/PAUSE (▶/)	S209 :18	
S112 :ONCE MORE	S210 :14	
S113 :INTRO		
IRKB ASSEMBLY		
S401 :POWER STANDBY / ON		

SCH-1

IRKB ASSY, FDKB ASSY, SDKB ASSY, FLKB ASSY, MIJB ASSY, HEPB ASSY, SYPS ASSY, VSBA ASSY, FG ASSY, PKSB ASSY, CAMB ASSY, LOSB ASSY, LOMB ASSY, PICKUP ASSY

CAUTION : FOR CONTINUED PROTECTION AGAINST RISK OF FIRE REPLACE WITH SAME TYPE NO. ICP-N20, MFD BY ROHM CO., LTD, FOR IC203.

- ➡: RF Signal Route
- ⇨: Tracking Servo Loop Line
- ⇩: Focus Servo Loop Line
- ⇦: Spindle Servo Loop Line
- ⚡: Audio Signal Route (L ch)
- ⚡: Audio Signal Route (MIC)

Q21-Q24 : SPINDLE PRE DRIVE
Q25 : SPINDLE DRIVE

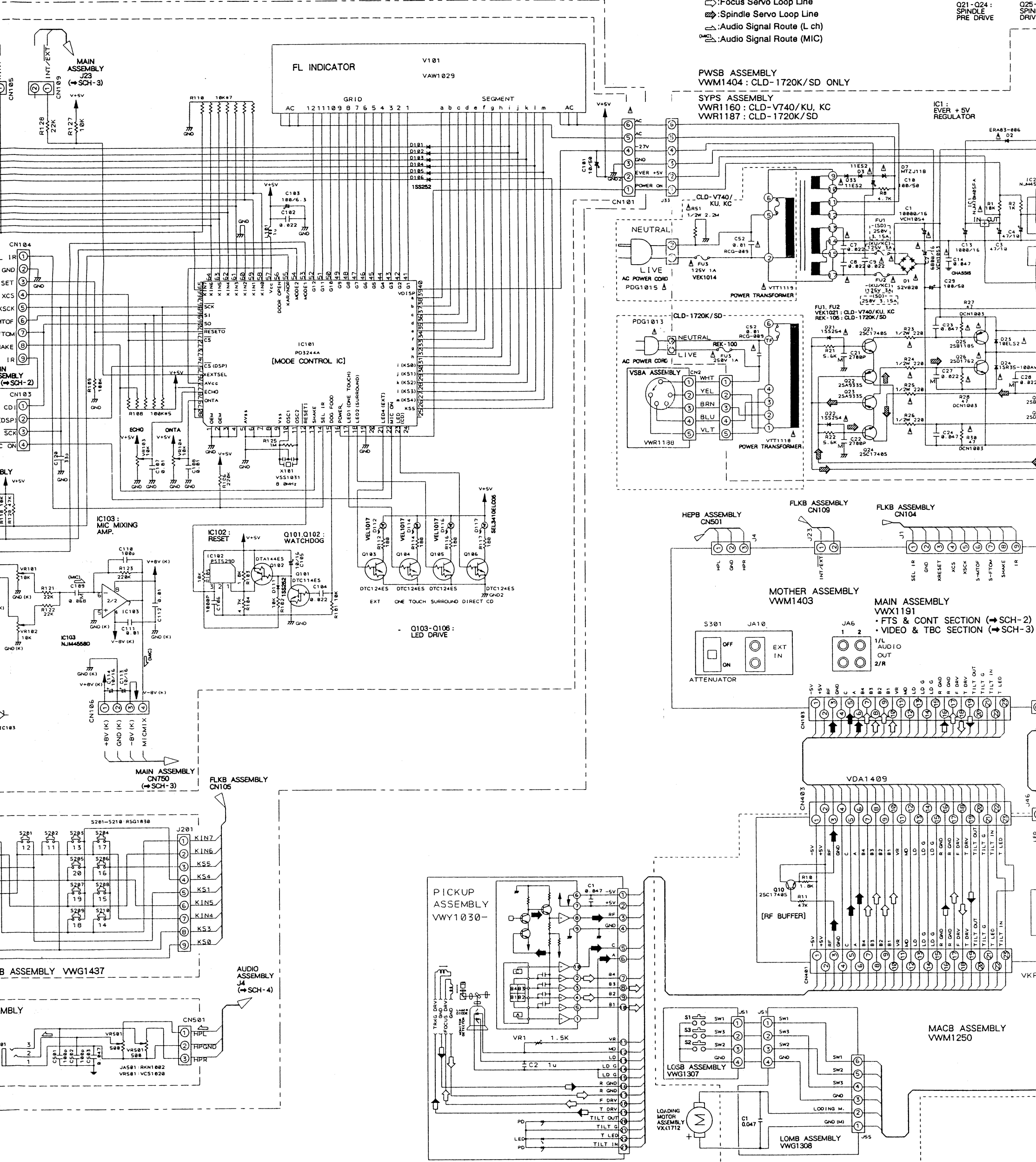

IRKB ASSY
FLKB ASSY
SYPS ASSY
PKSB ASSY

CAUTION: FOR CONTINUED PROTECTION AGAINST RISK OF FIRE REPLACE WITH SAME TYPE NO. ICP-N20, MFD BY ROHM CO., LTD, FOR IC203.

CAUTION: FOR CONTINUED PROTECTION AGAINST RISK OF FIRE REPLACE WITH SAME TYPE NO. ICP-N15, MFD BY ROHM CO., LTD, FOR IC201, IC202 AND IC204.

SCH-1 A

- ➔: RF Signal Route
- ➡: Tracking Servo Loop Line
- ➡: Focus Servo Loop Line
- ➡: Spindle Servo Loop Line
- ➡: Audio Signal Route (L ch)
- ➡: Audio Signal Route (MIC)

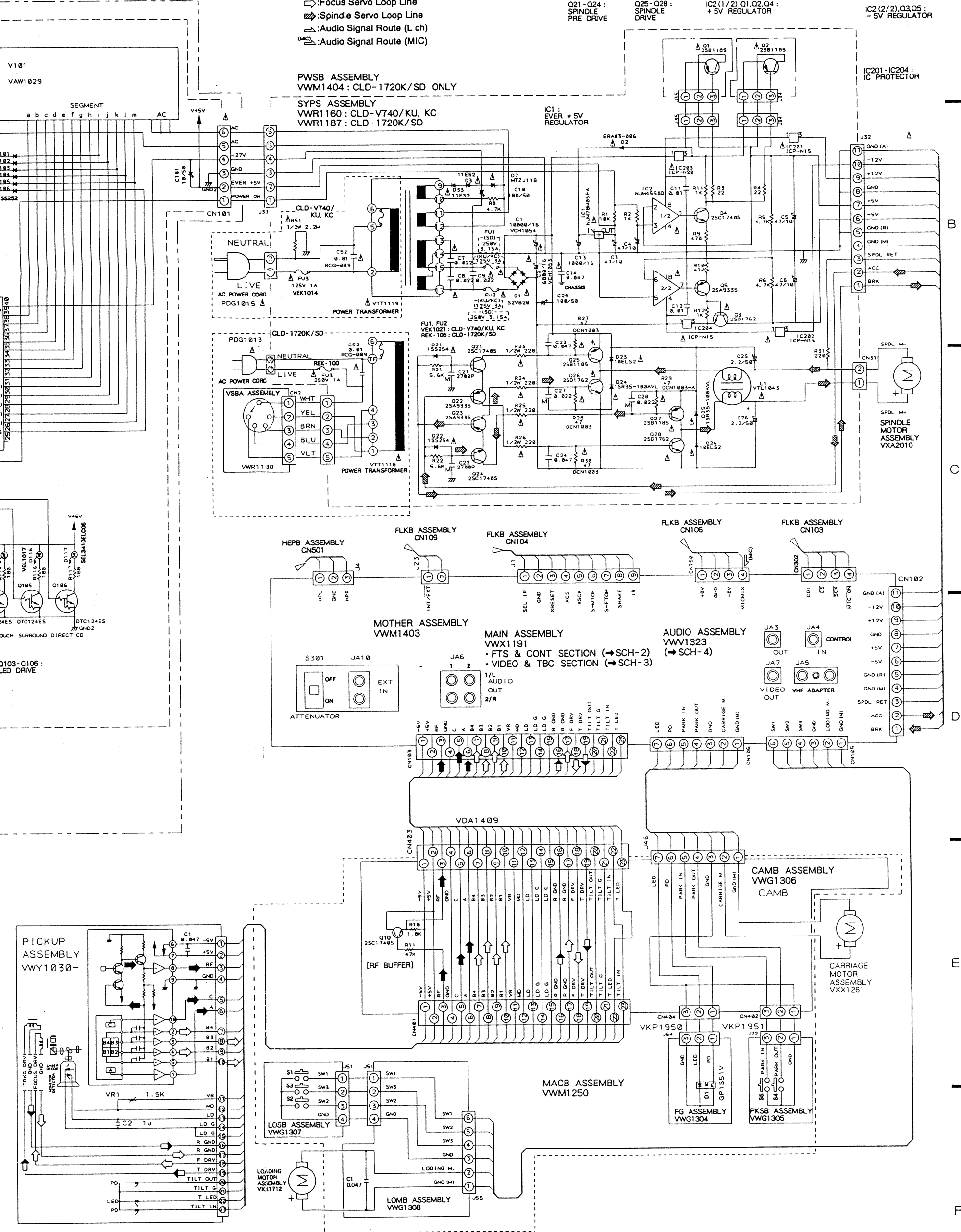

IRKB ASSY, FDKB ASSY, SDKB ASSY, FLKB ASSY, MIJB ASSY, HEPB ASSY, SYPS ASSY, VSBA ASSY, FG ASSY, PKSB ASSY, CAMB ASSY, LOSB ASSY, LOMB ASSY, PICKUP ASSY

SCH-1

A

B

C

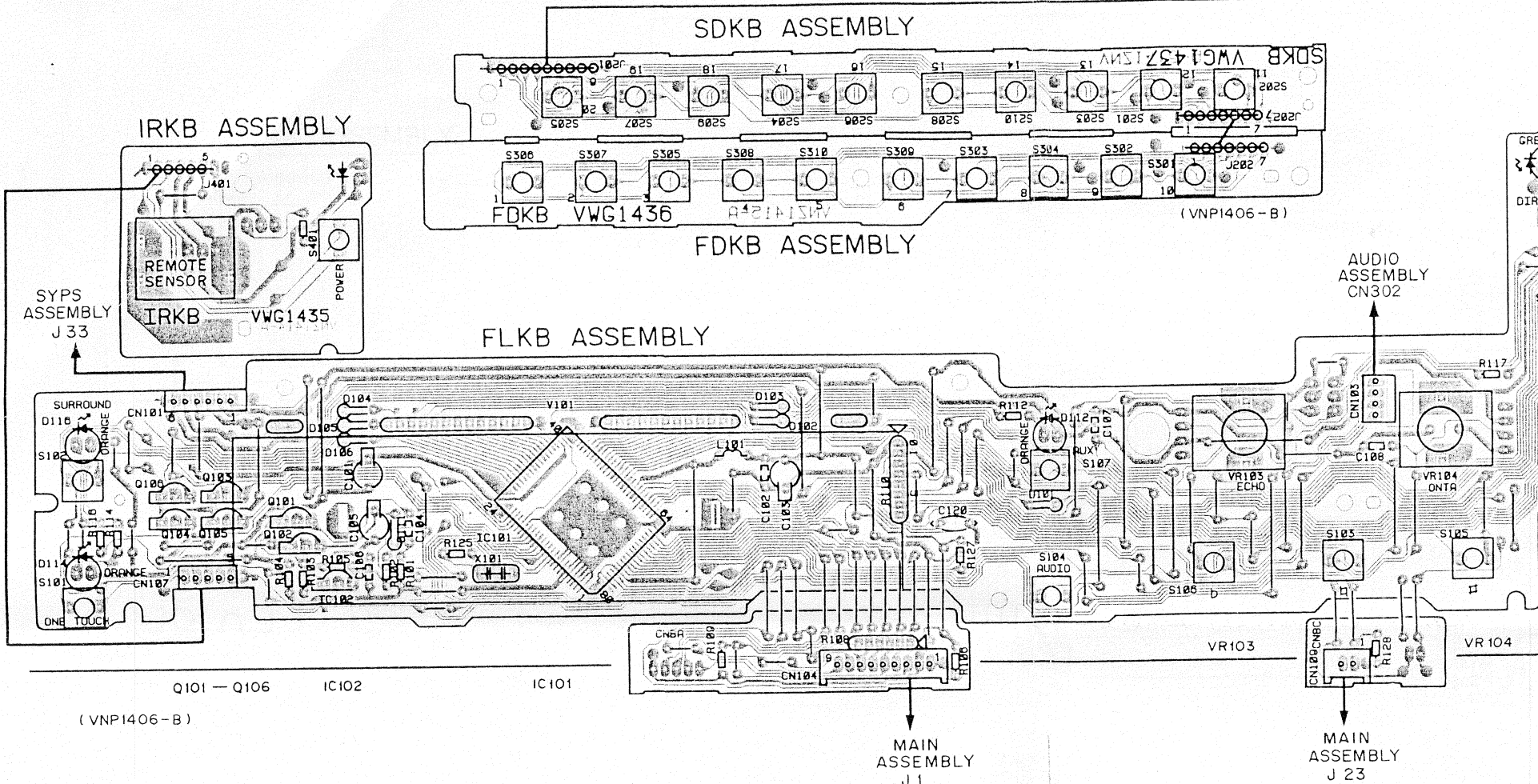

P.C.B. pattern diagram indication	Corresponding part symbol	Part name
		Transistor
		FET
		Diode
		Zener diode
		LED
		Varactor
		Tact switch
		Inductor
		Coil
		Transformer
		Filter
		Ceramic capacitor
		Mylar capacitor
		Styrol capacitor
		Electrolytic capacitor (Non polarized)
		Electrolytic capacitor (Noiseless)
		Electrolytic capacitor (Polarized)
		Electrolytic capacitor (Polarized)
		Power capacitor
		Semi-fixed resistor
		Resistor array
		Resistor
		Resonator
		Thermistor

1. This P.C.B. connection diagram is viewed from the parts mounted side.
2. The parts which have been mounted on the board can be replaced with those shown with the corresponding wiring symbols listed in the above Table.
3. The capacitor terminal marked with shows negative terminal.
4. The diode marked with shows cathode side.
5. The transistor terminal marked with shows emitter.

CLD-V740/KU, KC

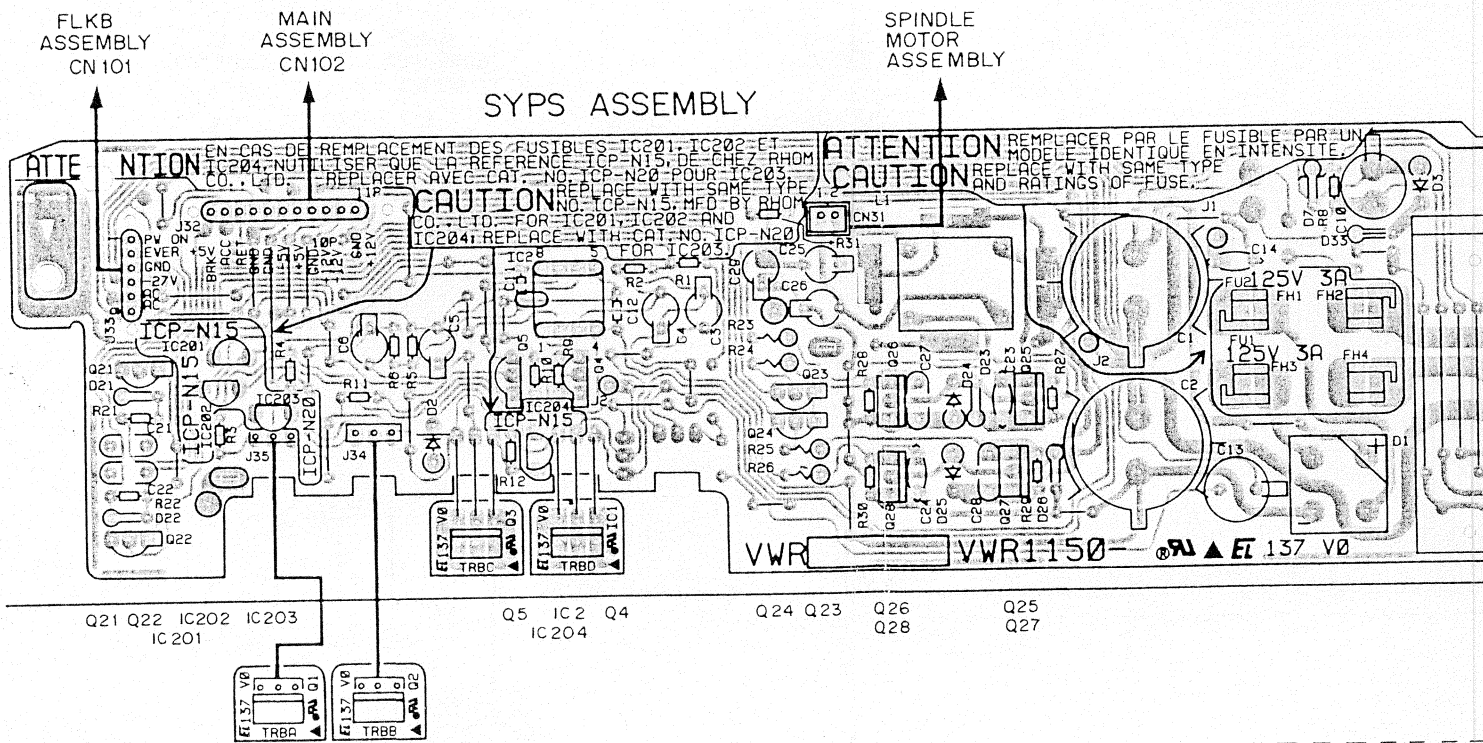

CLD-1720K/SD

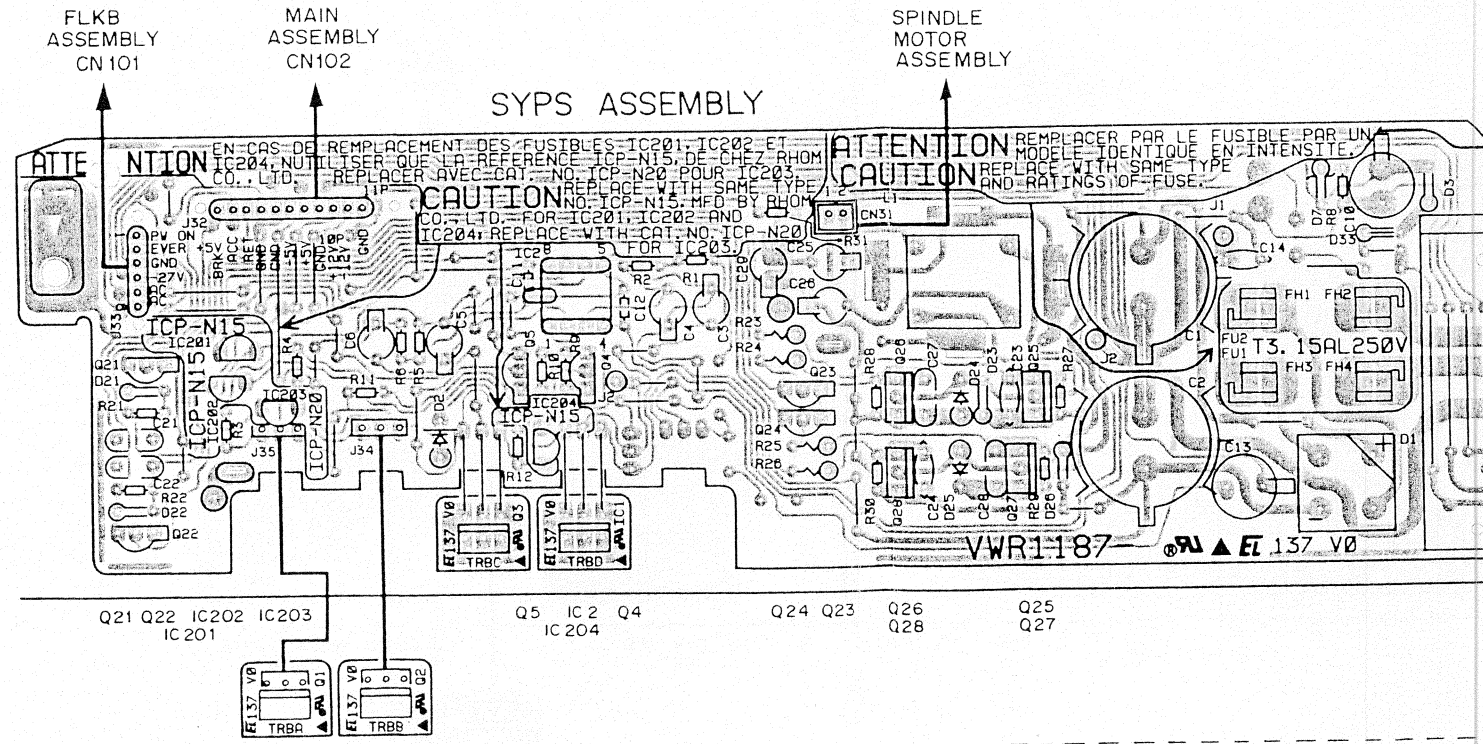

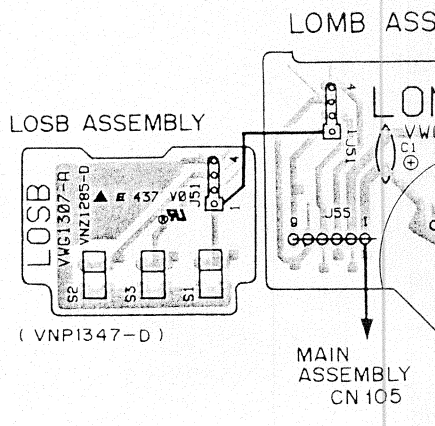
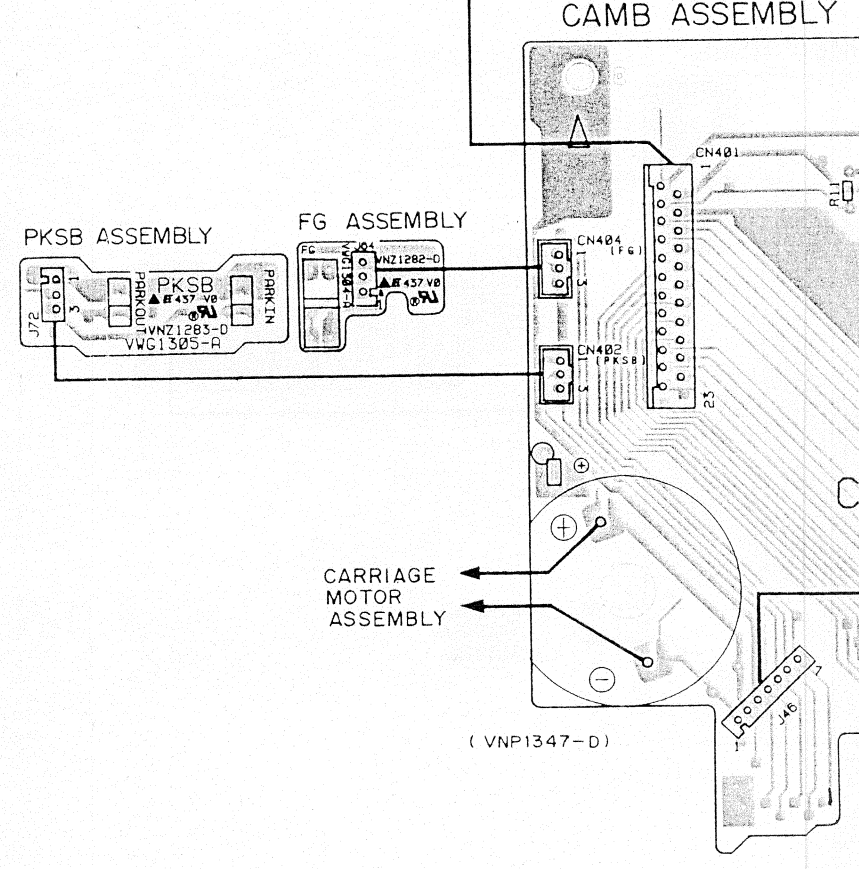
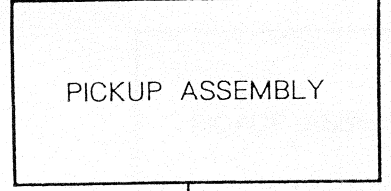
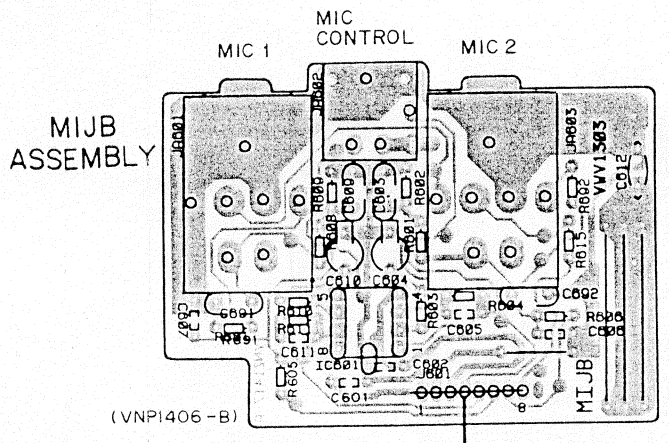
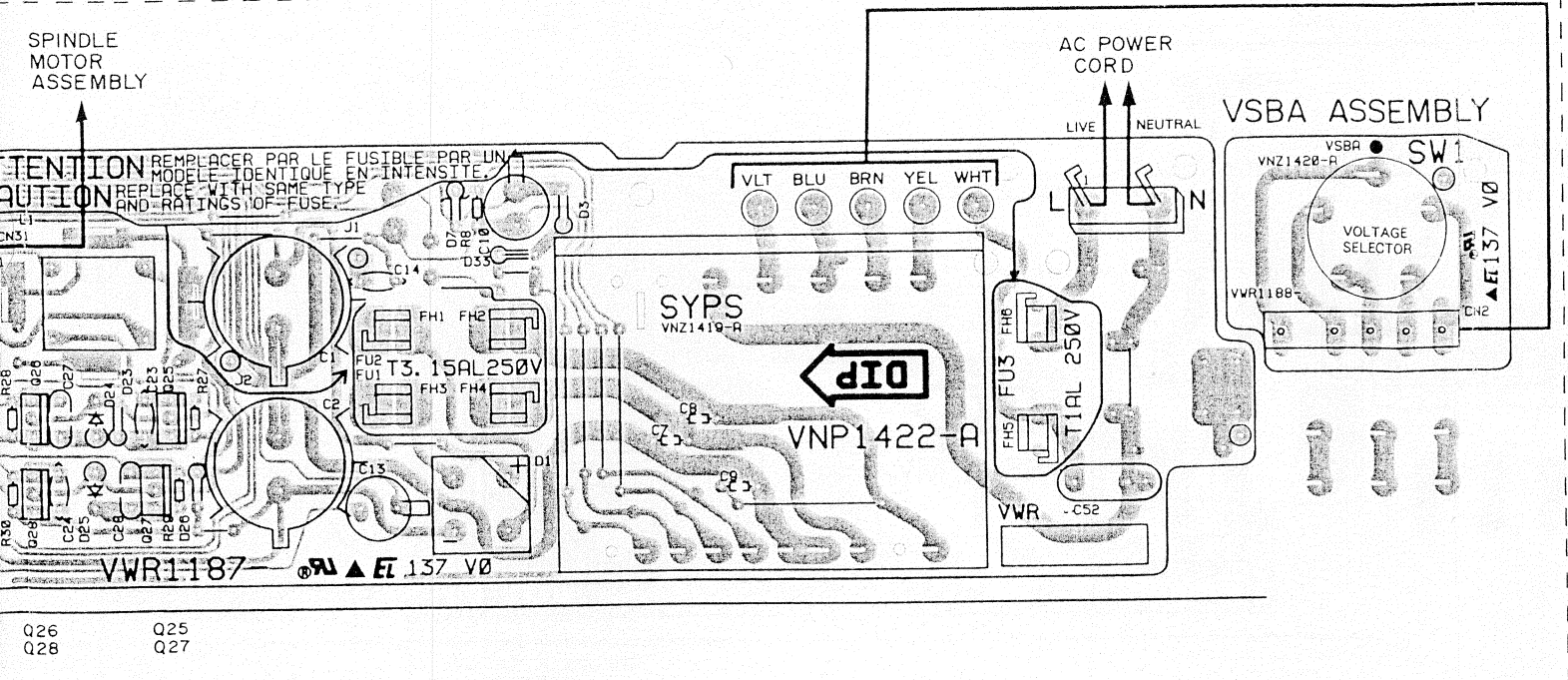
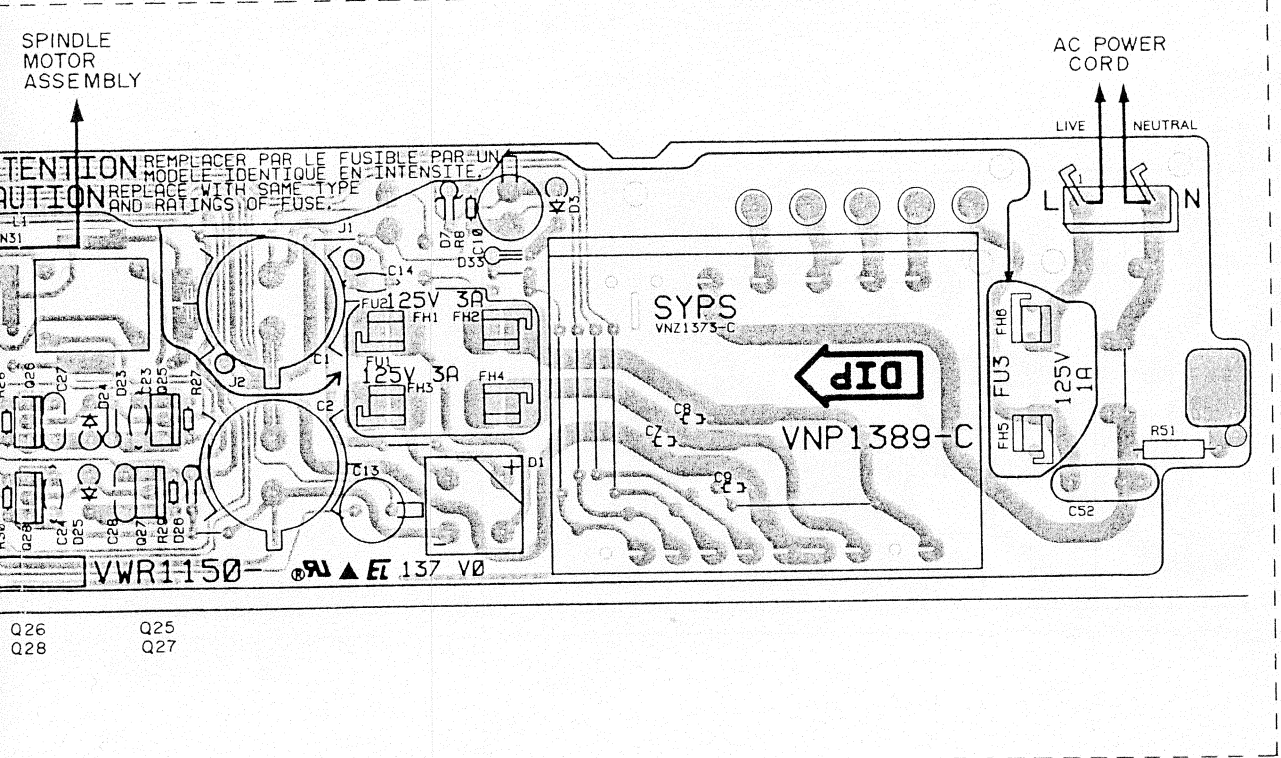
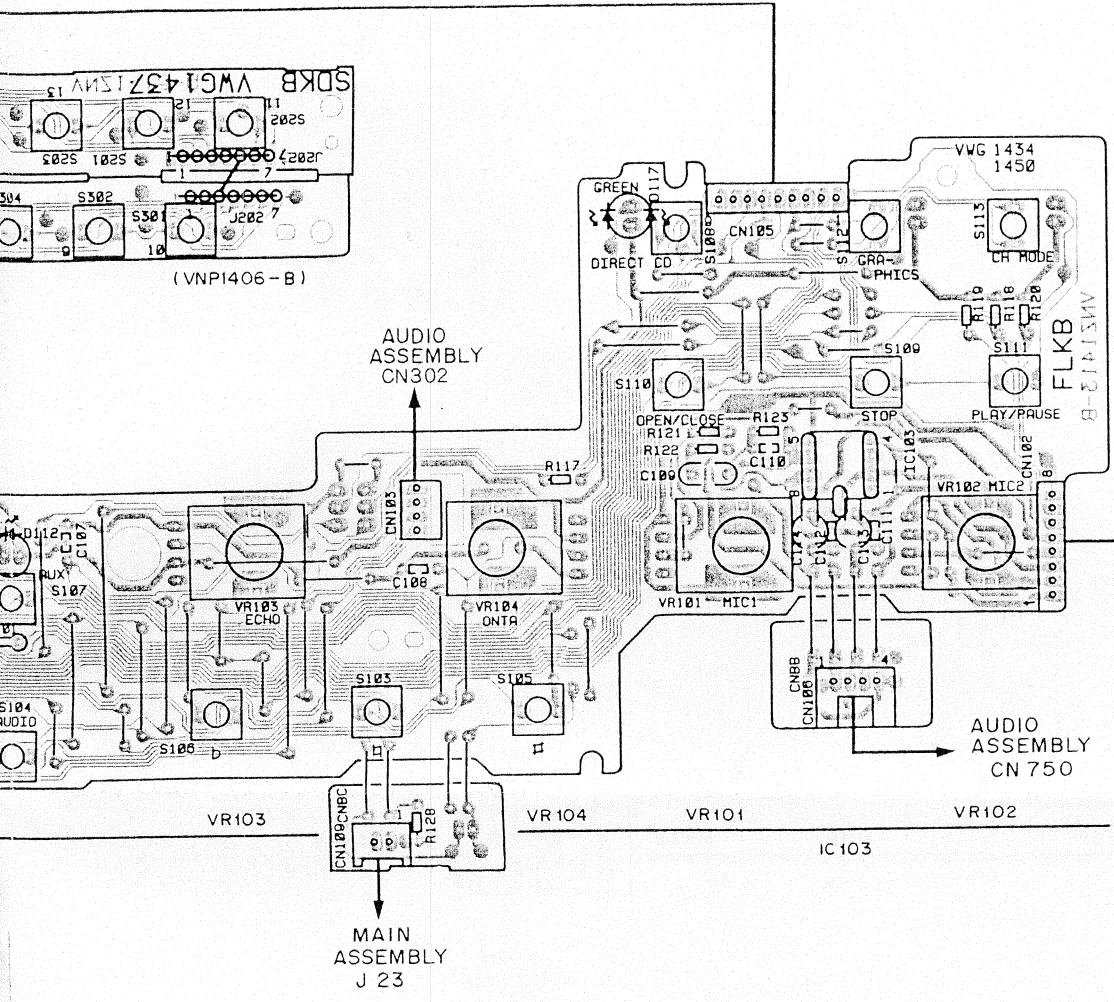

6

7

8

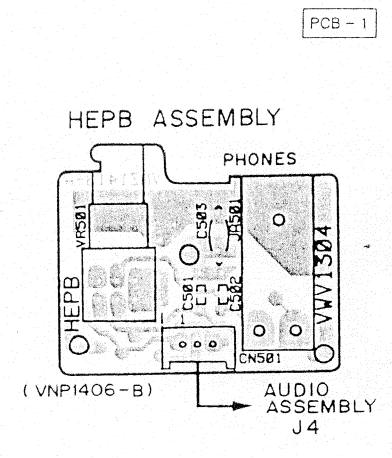
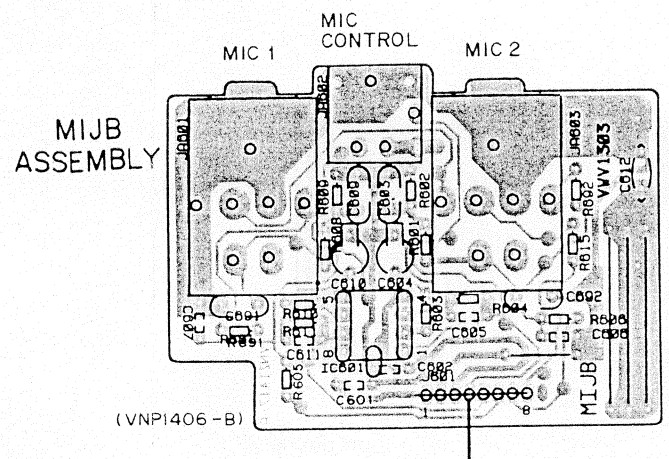
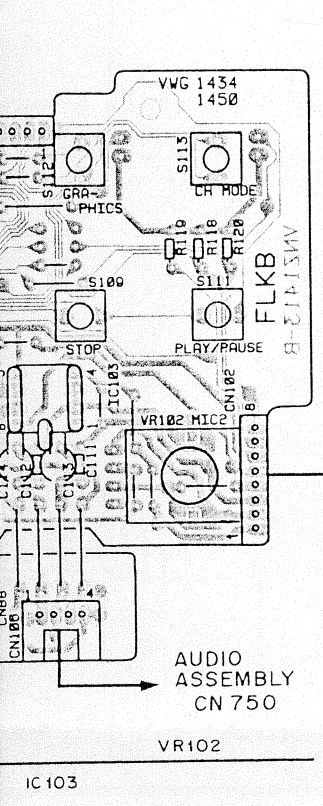

A

B

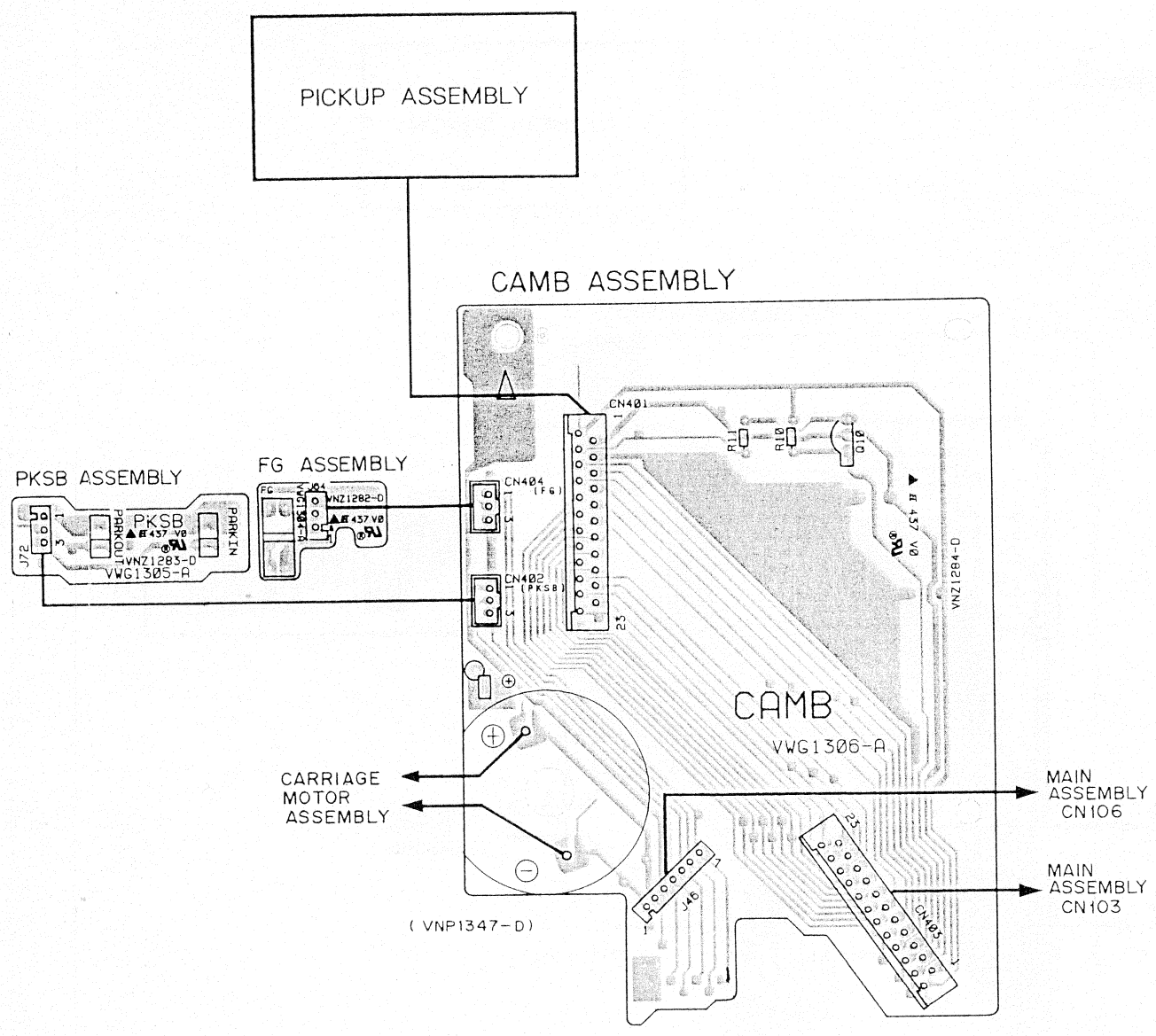
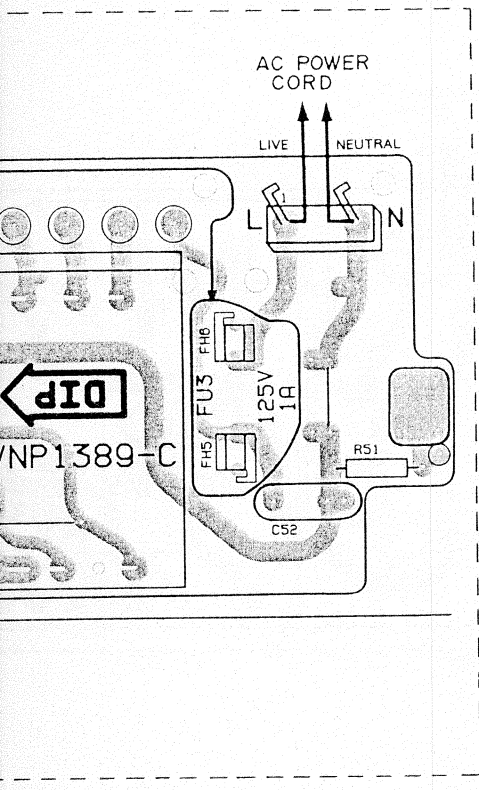

C

D

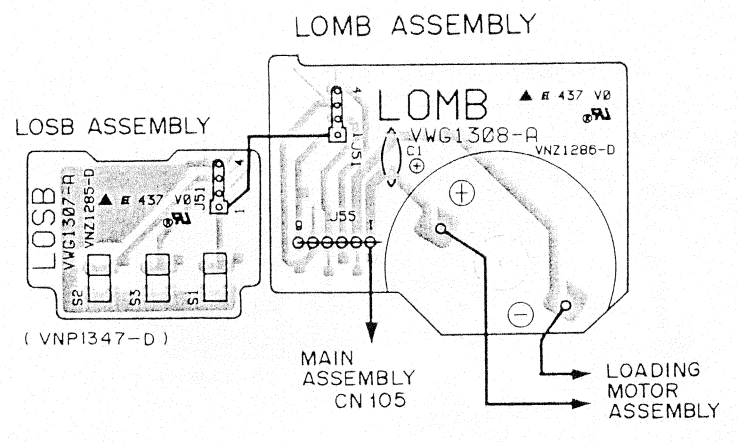
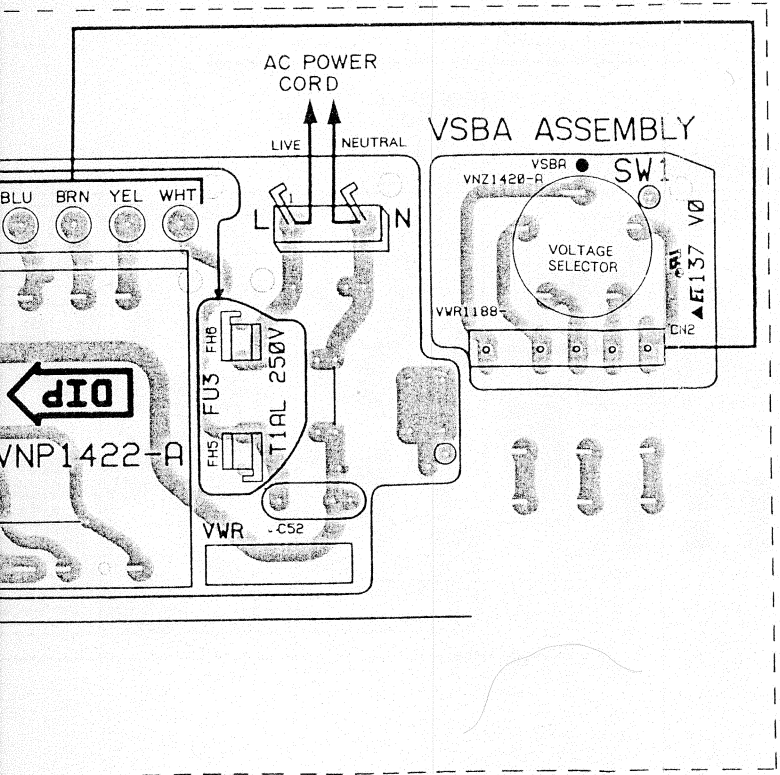

E

F

This P. C. B. connection diagram is viewed from the parts mounted side.

6

7

8

9

A
B
C
D
E
F

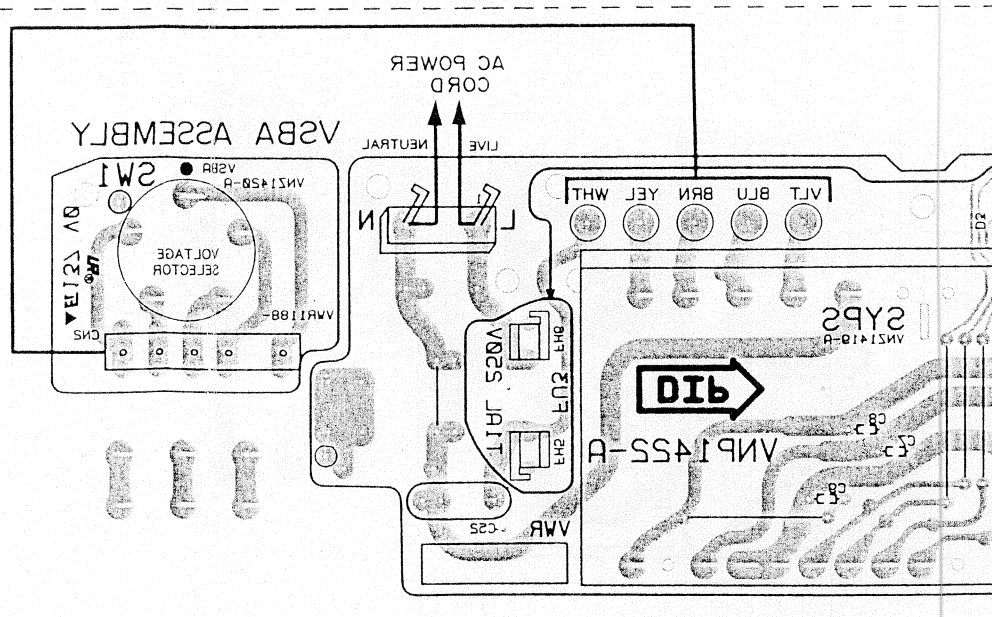
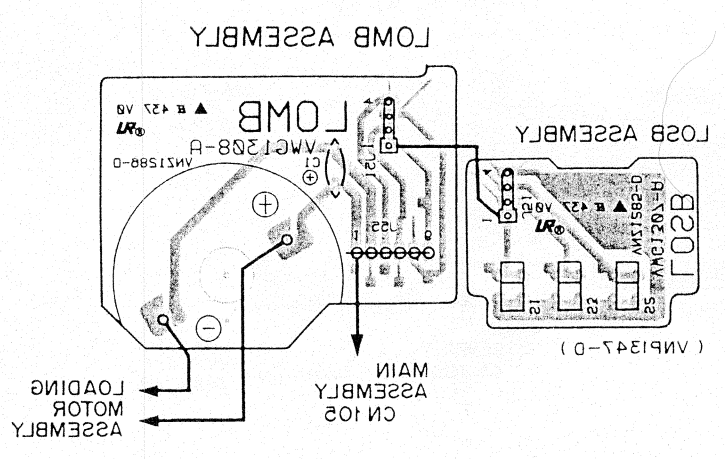
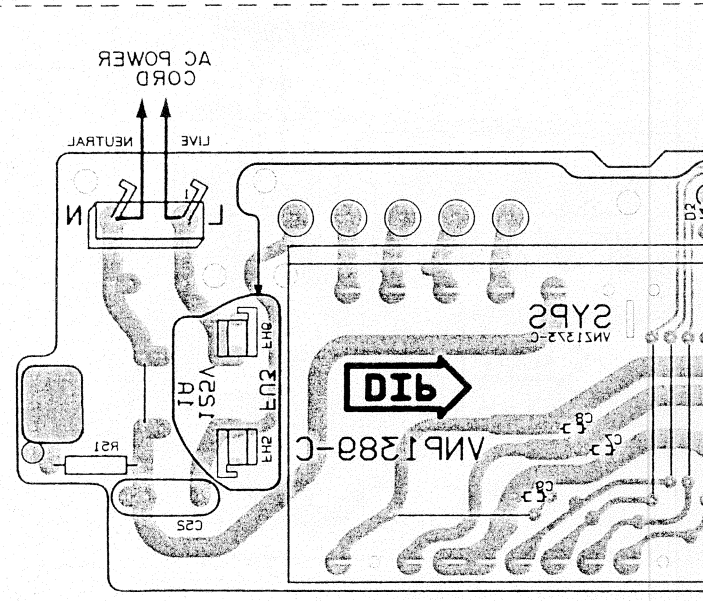
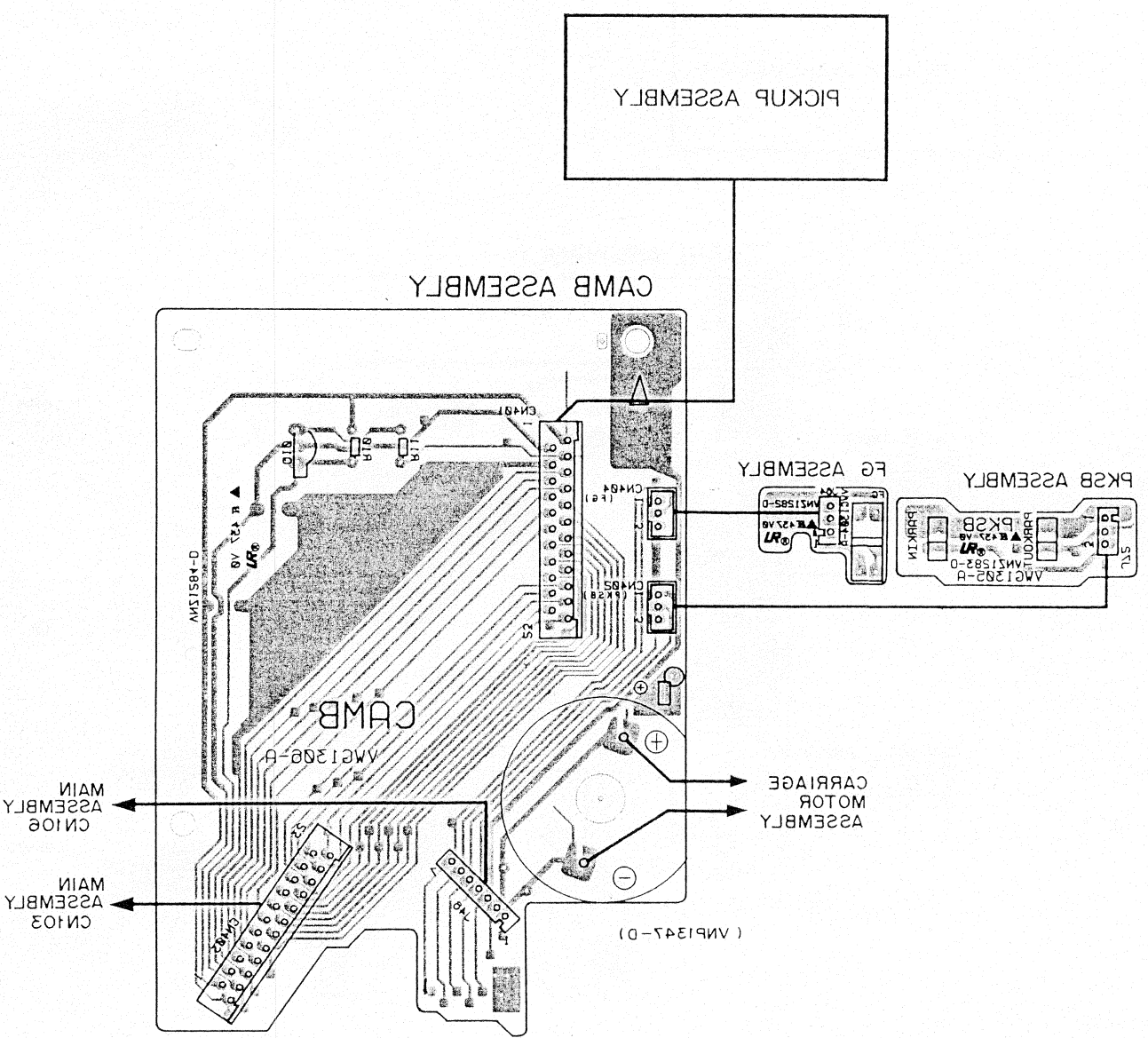
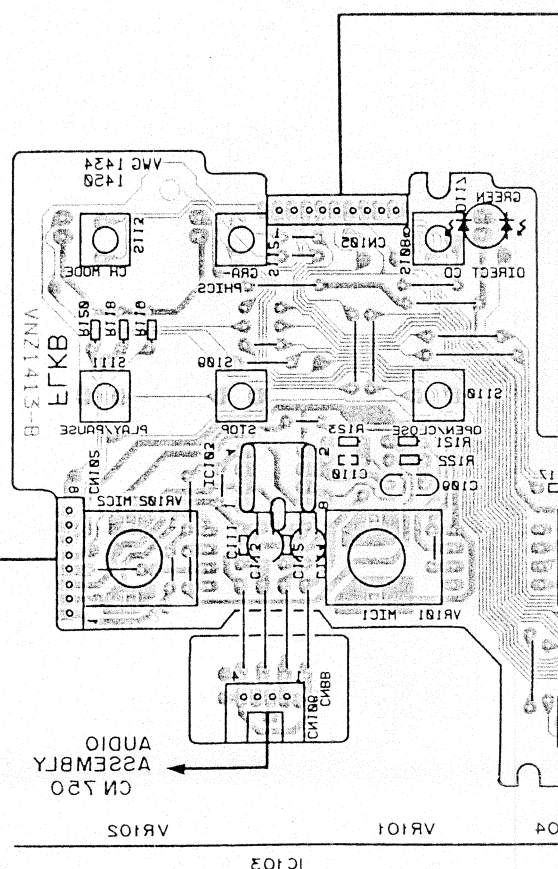
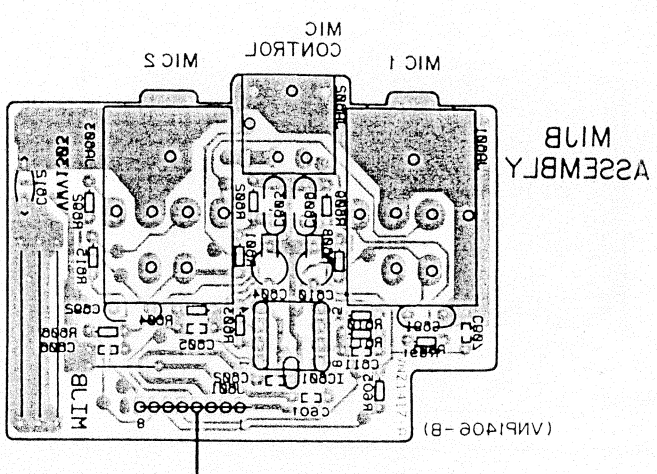
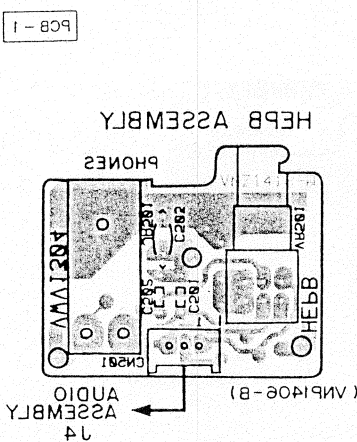

This P. C. B. connection diagram is viewed from the foil side.

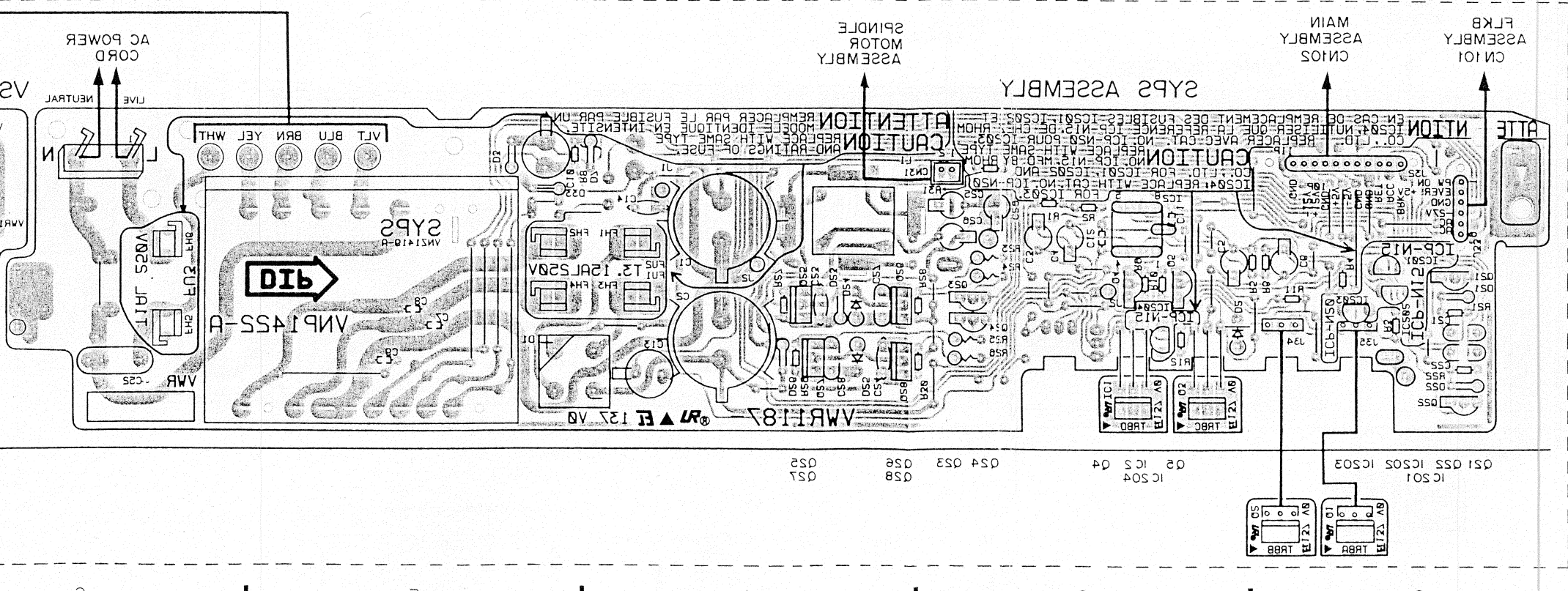
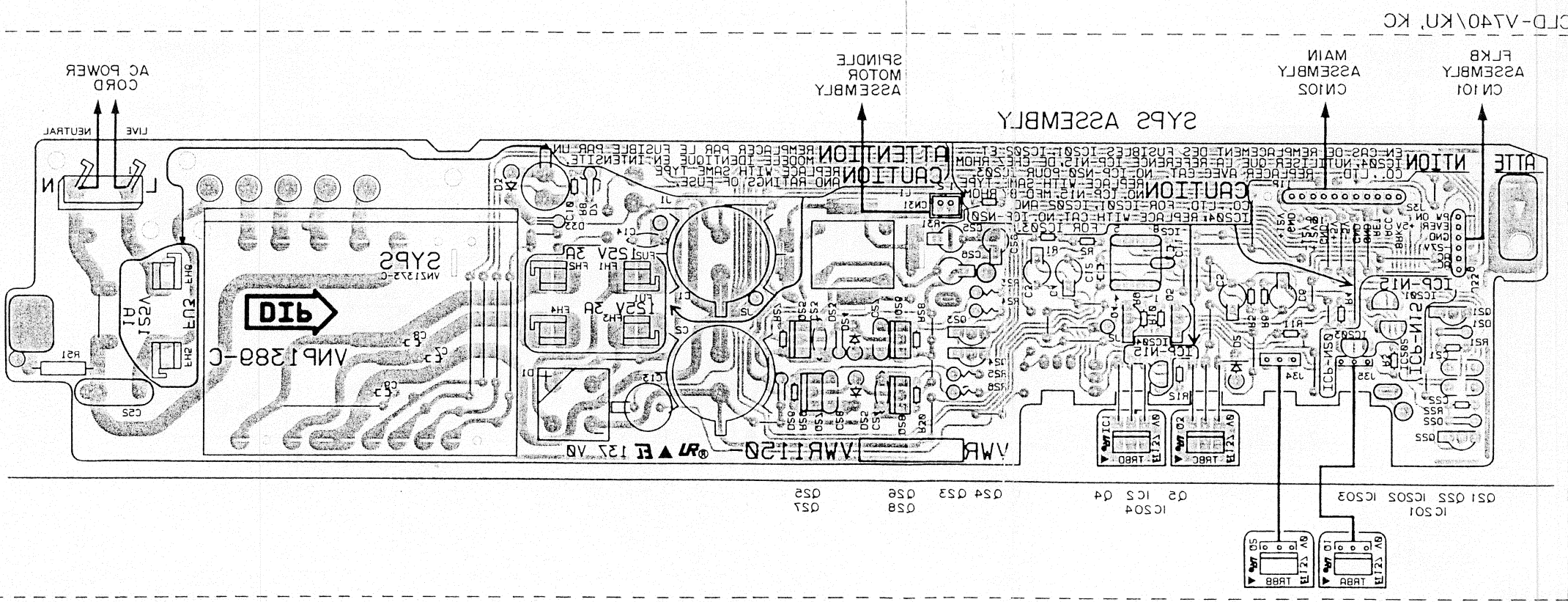
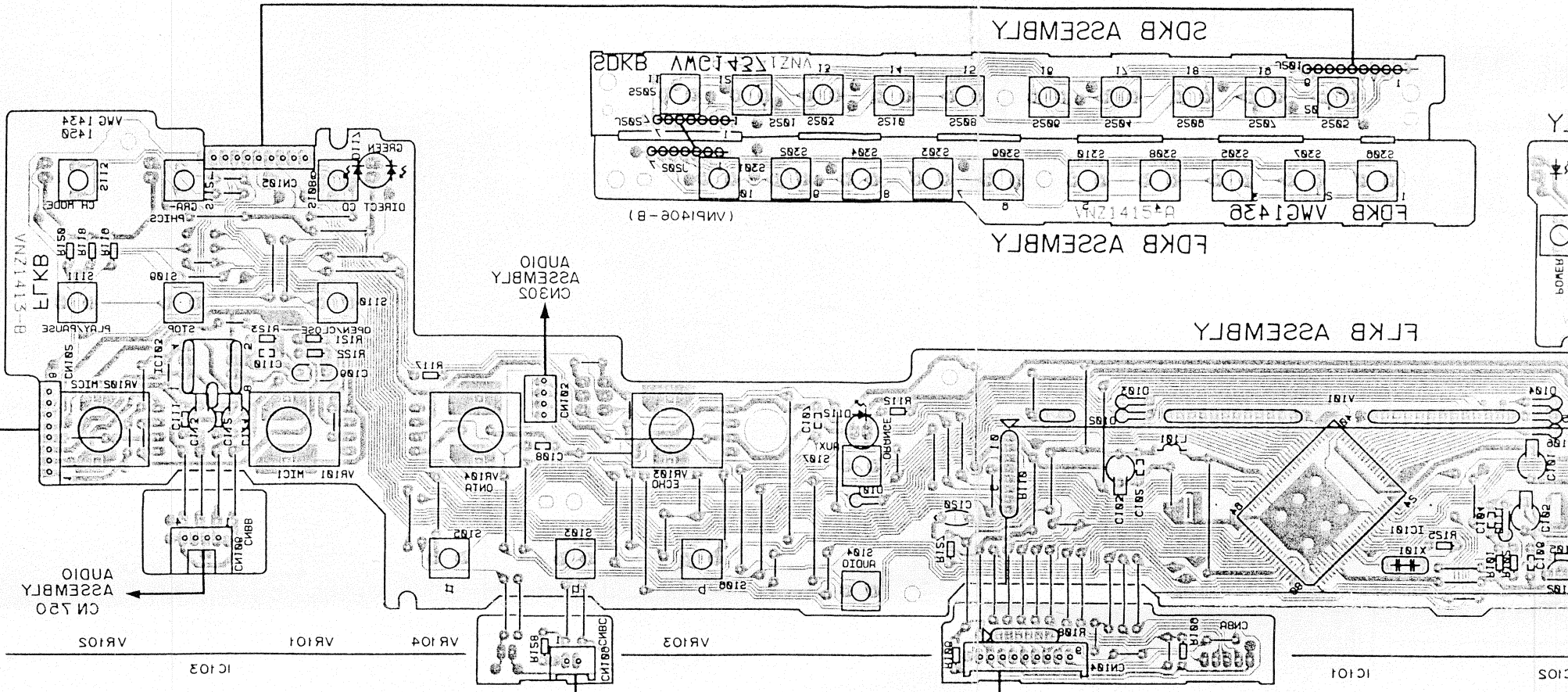

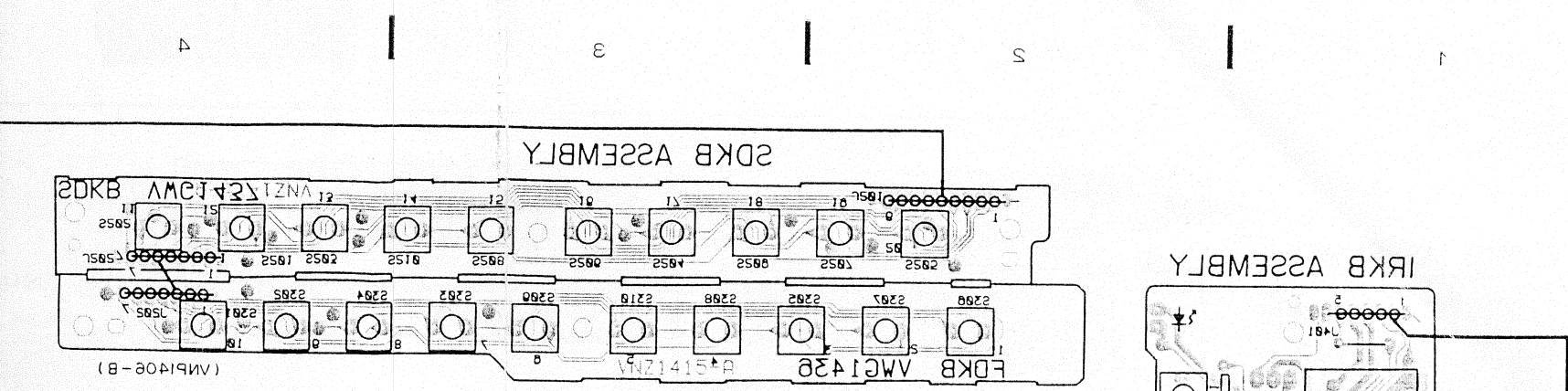
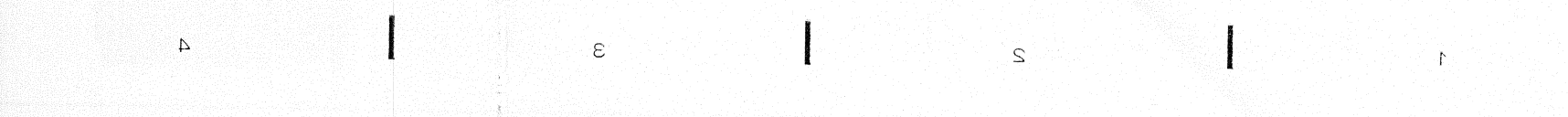
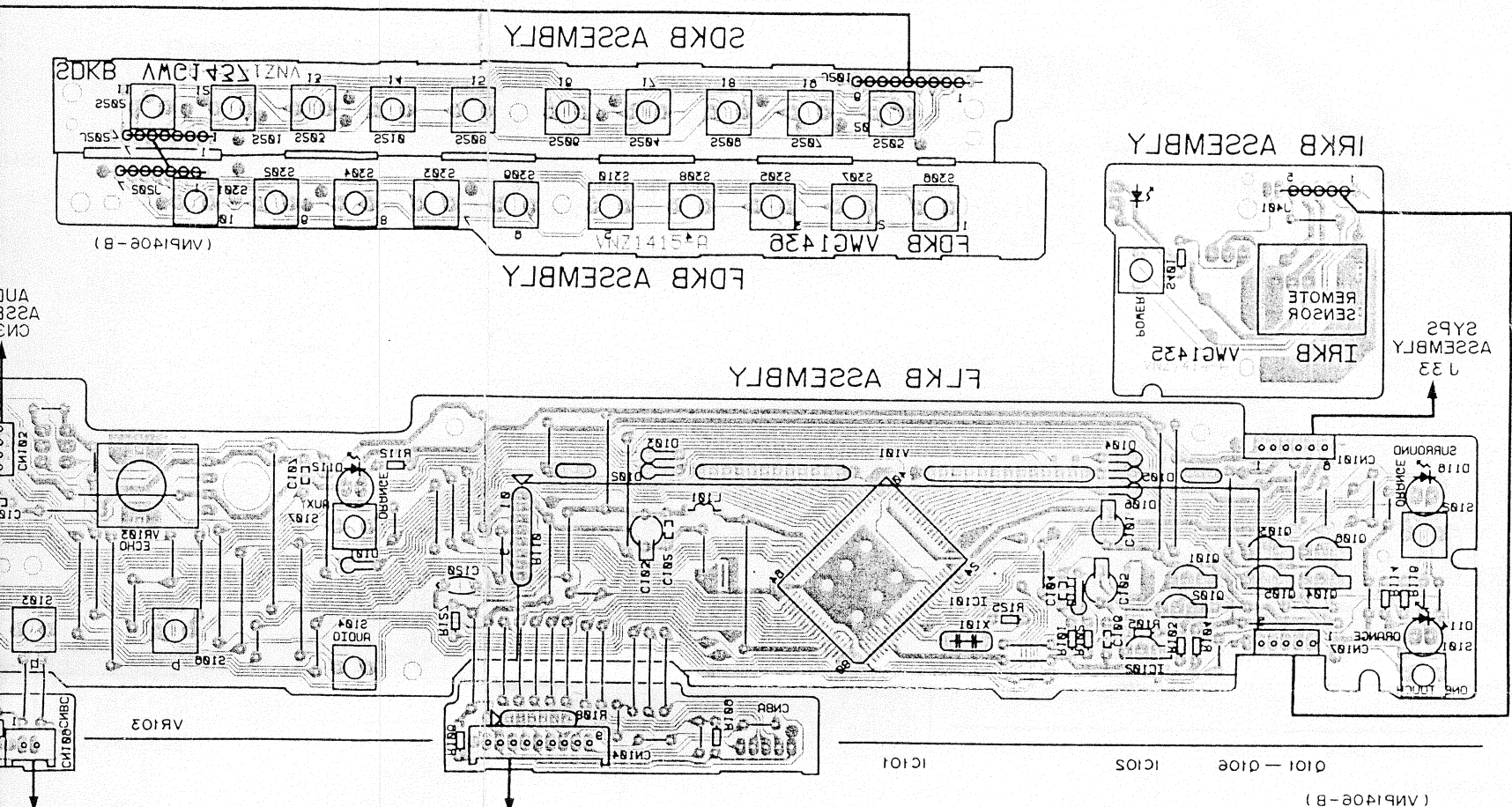
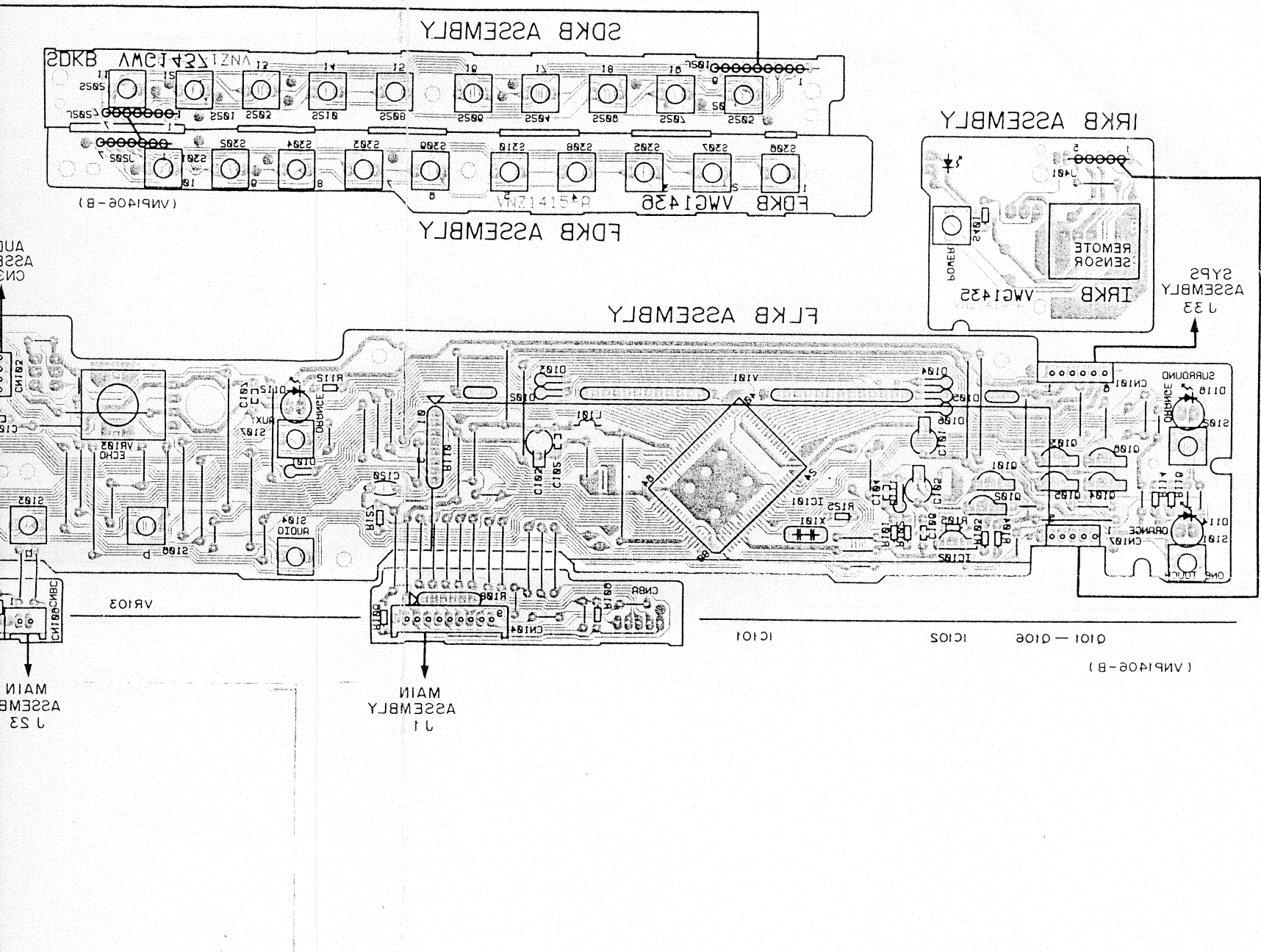
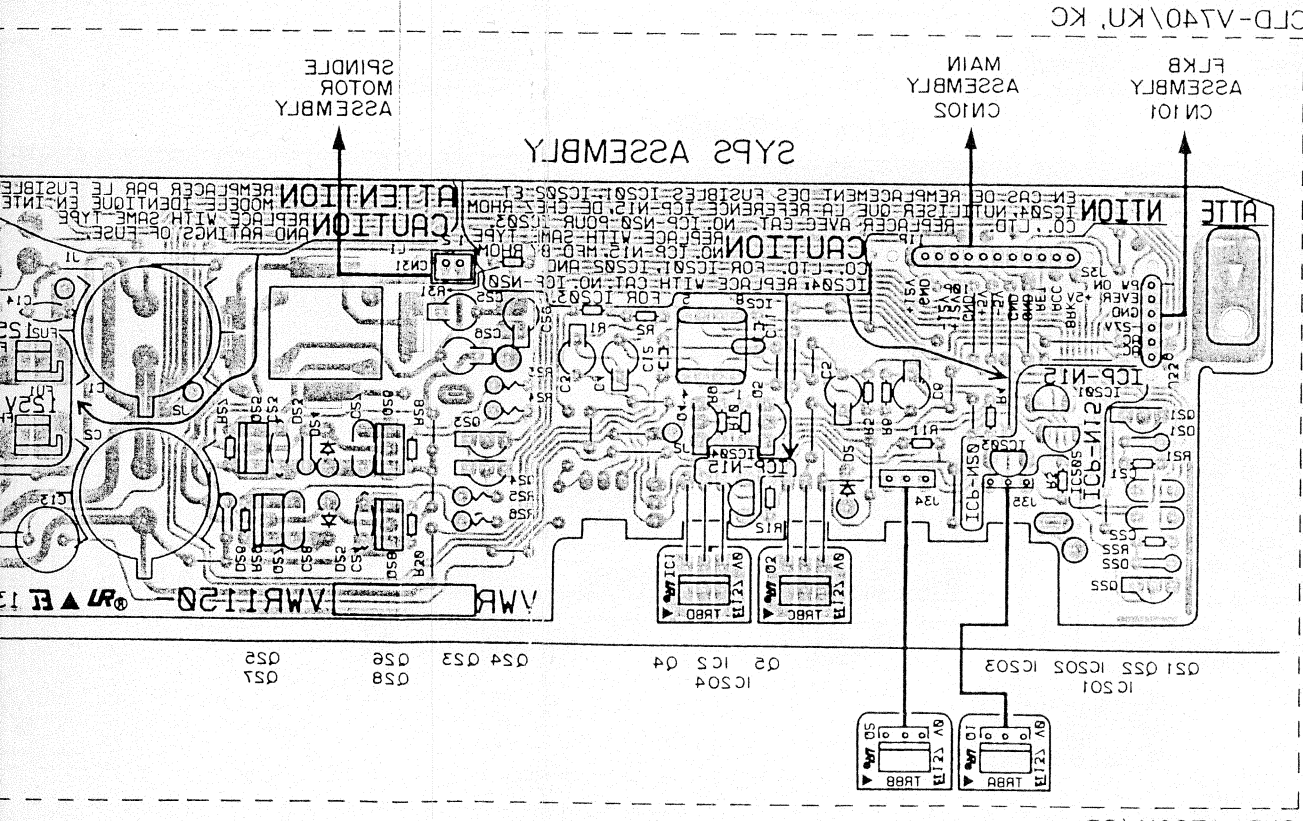
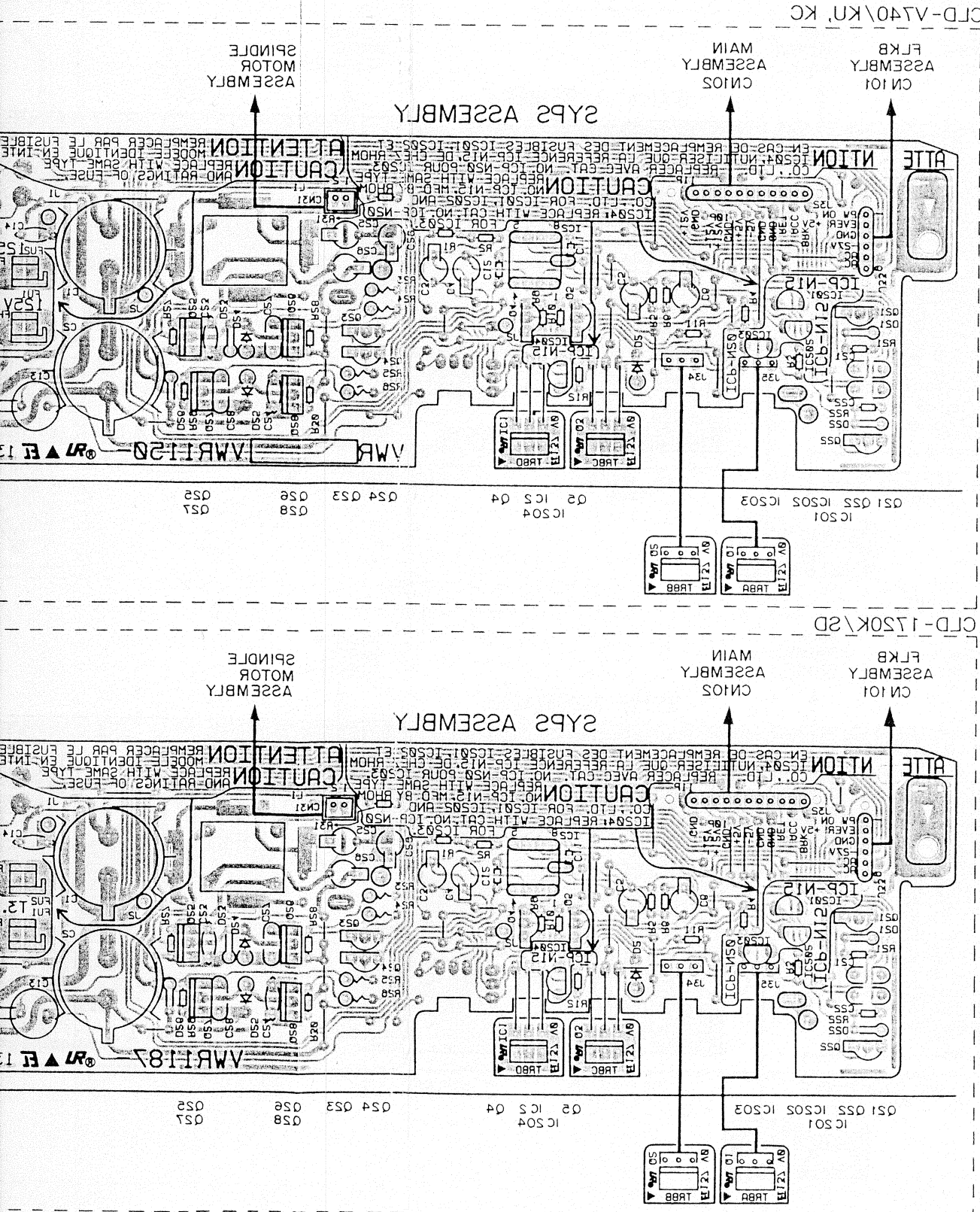

A
 B
 C
 D
 E
 F

● Waveforms
FTS AND CONT SECTION

Note: (No.) in the table correspond to the pin number.
 Waveforms are at the PLAY mode.

IC101 (PD0133C)	IC801 (CXA1081S)	IC802 (CXA1372S)	CN120	Others Point
⑧ H:5mS/div 2Vp-p 0V DC mode	② H:10mS/div 1.7Vp-p AC mode	① H:10mS/div 50mVp-p 0V DC mode	① H:10mS/div 130mVp-p AC mode	① Q815 Collector H:1mS/div 5Vp-p 0V DC mode
⑩ H:10mS/div 5Vp-p 0V DC mode	⑦ H:5mS/div 50mVp-p 0V DC mode	⑪ H:1mS/div 1.2Vp-p 0V DC mode	② H:10mS/div 130mVp-p AC mode	② Q805 Emitter H:5mS/div 2Vp-p 0V DC mode
⑪ H:10mS/div 5Vp-p 0V DC mode	⑧ H:10mS/div 40mVp-p 0V DC mode	⑰ H:1mS/div 2.5Vp-p 0V DC mode	③ H:5mS/div 330mVp-p AC mode	③ Q807 Collector H:5mS/div 1Vp-p 0V DC mode
⑫ H:0.5mS/div 2.3Vp-p 0V DC mode	⑫ H:10mS/div 200mVp-p AC mode		④ H:10mS/div 7.5Vp-p AC mode	
⑮ H:10mS/div 5Vp-p 0V DC mode	⑳ H:10mS/div 0.35Vp-p 0V DC mode		⑤ H:10mS/div 13.6Vp-p AC mode	
⑯ H:2mS/div 4.7Vp-p 0V DC mode			⑥ H:10mS/div 2.3Vp-p AC mode	
			⑦ H:10mS/div 2.3Vp-p AC mode	
			⑨ H:10mS/div 1.3Vp-p AC mode	
			⑩ H:10mS/div 1.3Vp-p AC mode	
			⑪ H:10mS/div 1Vp-p AC mode	

A

B

C

D

E

F

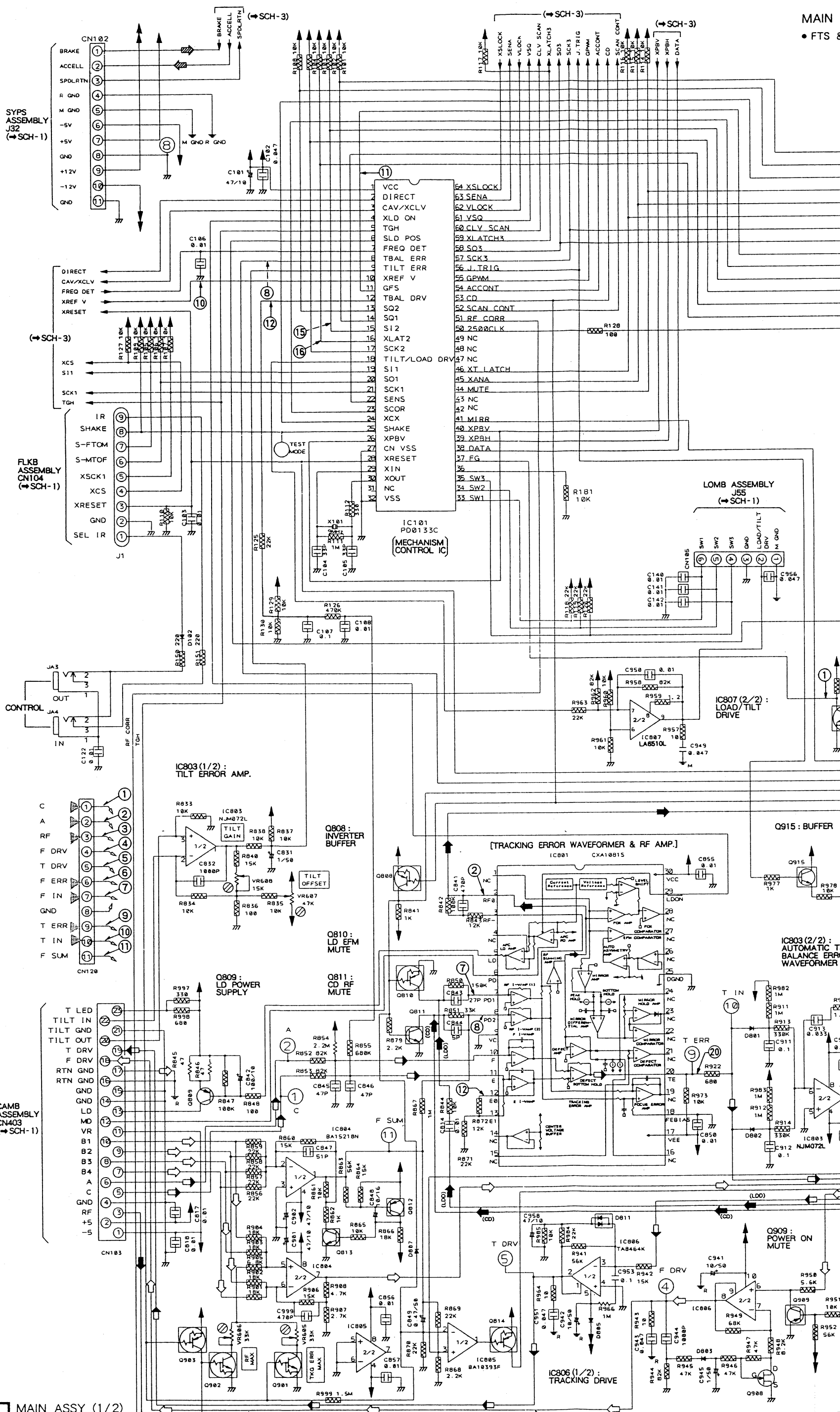

SCH-2

MAIN ASSY (1/2)
(FTS & CONT)

Q901-Q903 : TRACKING MAX/RF MAX VR SWITCHING

IC804 (2/2) : FOCUS ERROR AMP.

IC804 (1/2), Q812, Q813 : FOCUS SUM AMP.

IC805, Q814 : MIRR COMPARATOR

IC806 (2/2), Q908 : FOCUS DRIVE

MAIN ASSEMBLY (1/2) : VWX1191

• FTS & CONT SECTION

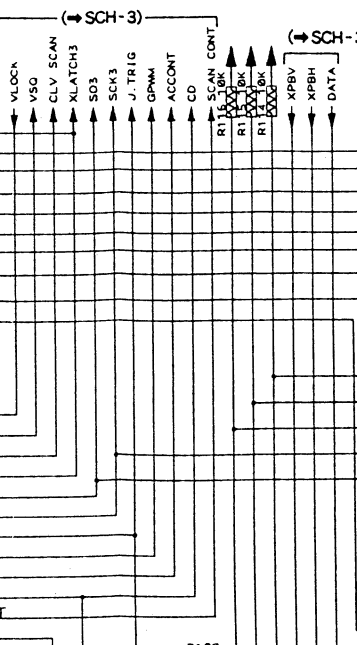
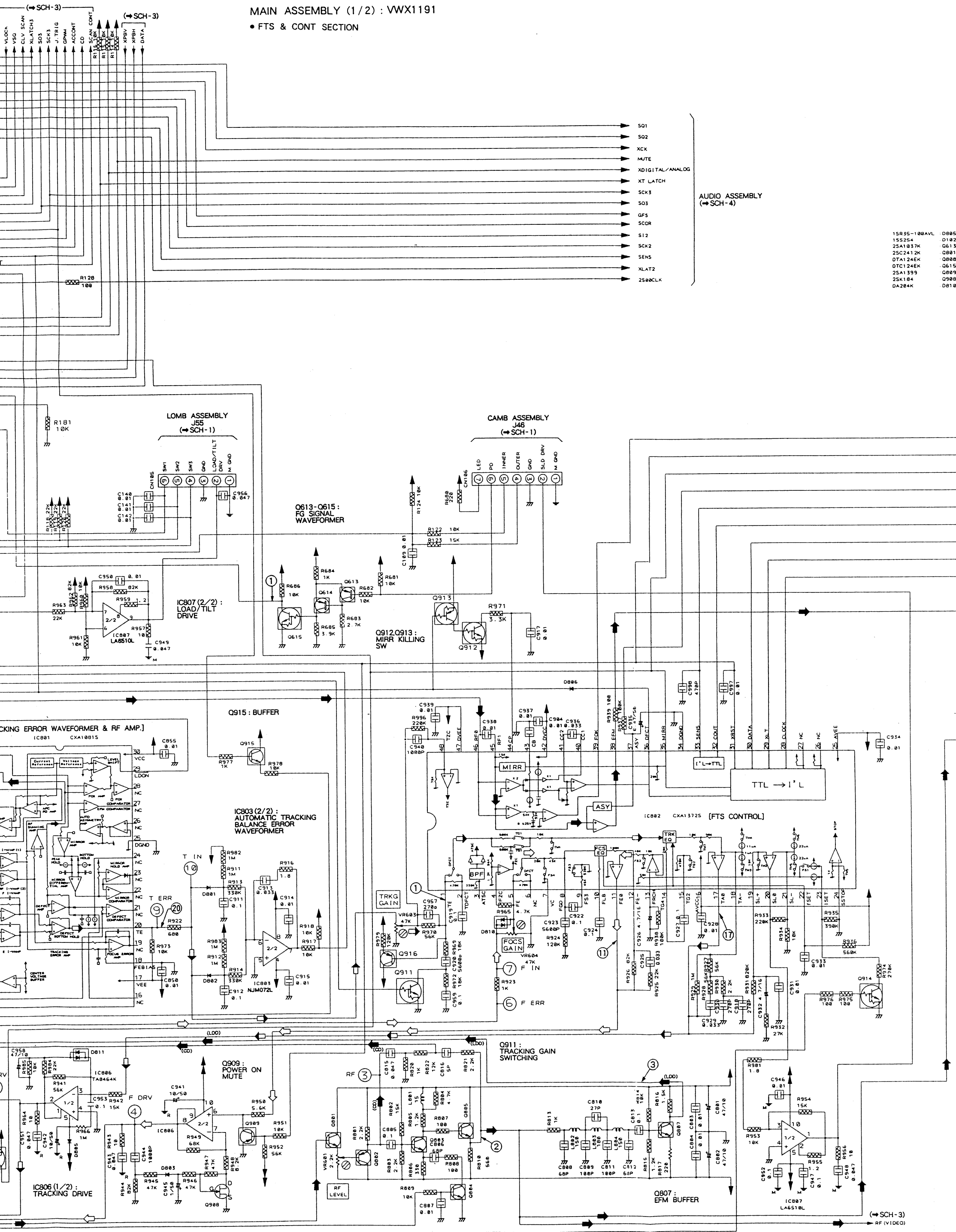

AUDIO ASSEMBLY
(SCH-4)

15R55-100AVL	D885
15S254	D182
25A1037K	D613
25C2412K	D881
DTA124EK	D808
DTA124EK	D615
25A1399	D889
25K184	D988
DA284K	D819

IC805.0814 : MIRR COMPARATOR IC806 (2/2).Q908 : FOCUS DRIVE Q801.Q802 : RF BUFFER Q803 : RF AMP. Q804 : RF CORRECTION Q805 : RF BUFFER IC807 (1/2) : SLIDER DRIVE

A

- ➔: RF Signal Route
- (CD) ➔: RF Signal Route (CD)
- (LDD) ➔: RF Signal Route (LDD)
- ◻: Tracking Servo Loop Line
- ◻: Focus Servo Loop Line
- ▨: Spindle Servo Loop Line

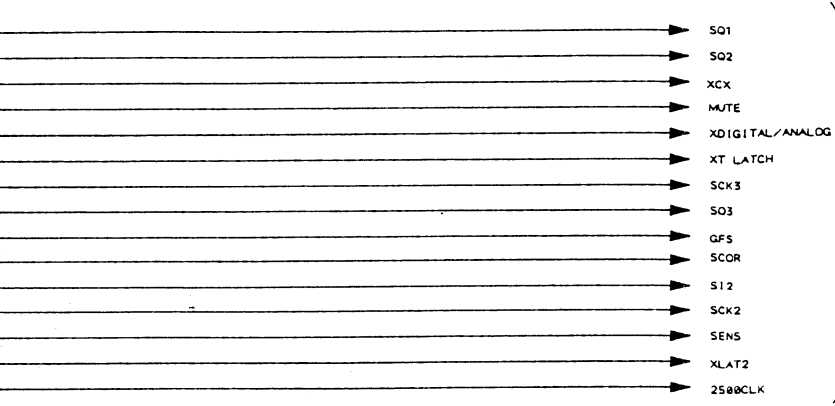

AUDIO ASSEMBLY
(SCH-4)

15R35-100AVL	: D895
15S254	: D182 081 082 083 086 087
25A1037K	: Q613 614 082 012 989 916
25C2412K	: Q801 083 084 085 087 011 013 915
DTA124EK	: Q808 010 014 903 913
OTC124EK	: Q615 981 982 911 912 914
25A1399	: Q809
25K184	: Q908
DA284K	: D810 011

B

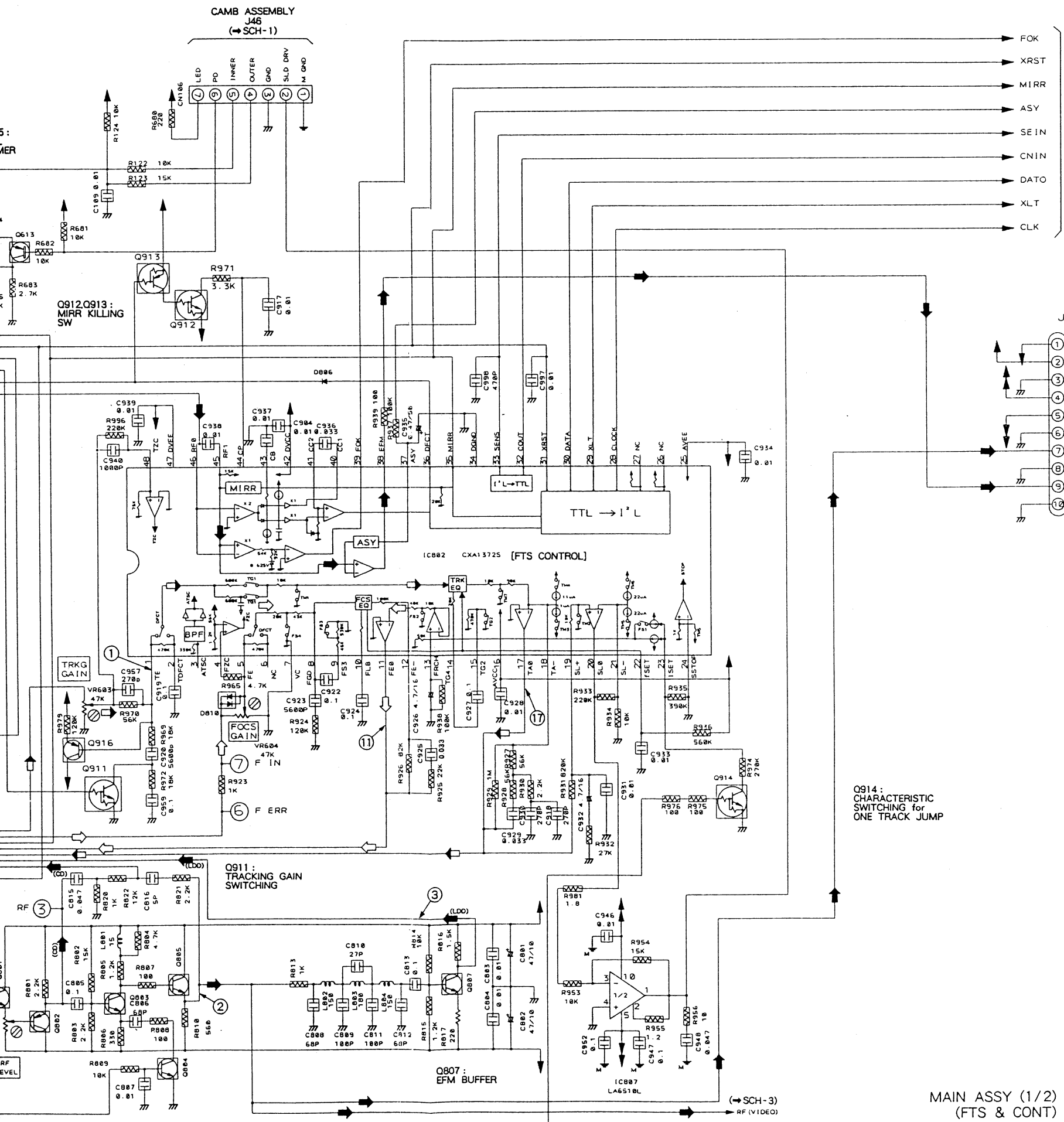

AUDIO ASSEMBLY
(SCH-4)

AUDIO ASSEMBLY
J9
(SCH-4)

Q914 :
CHARACTERISTIC
SWITCHING for
ONE TRACK JUMP

C

D

E

F

MAIN ASSY (1/2)
(FTS & CONT)

SCH-2

Q801, Q802 :
E BUFFER

Q803 :
RF AMP.

Q804 :
RF CORRECTION

Q805 :
RF BUFFER

IC807 (1/2) :
SLIDER DRIVE

3.3 MAIN ASSEMBLY (2/2)

MAIN ASSEMBLY (2/2) : VWX1191
• VIDEO & TBC SECTION

A
B
C
D
E
F

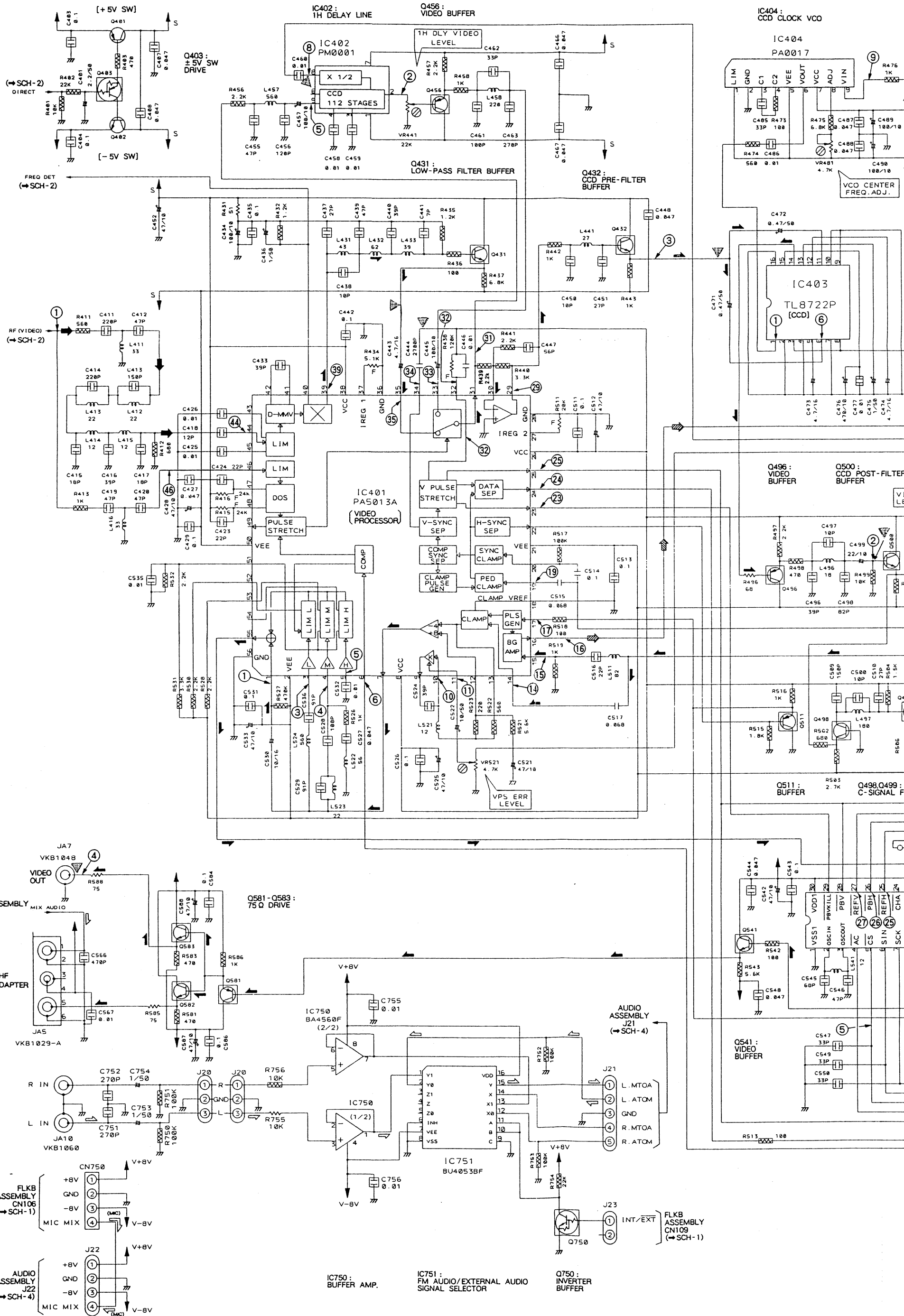

SCH-3

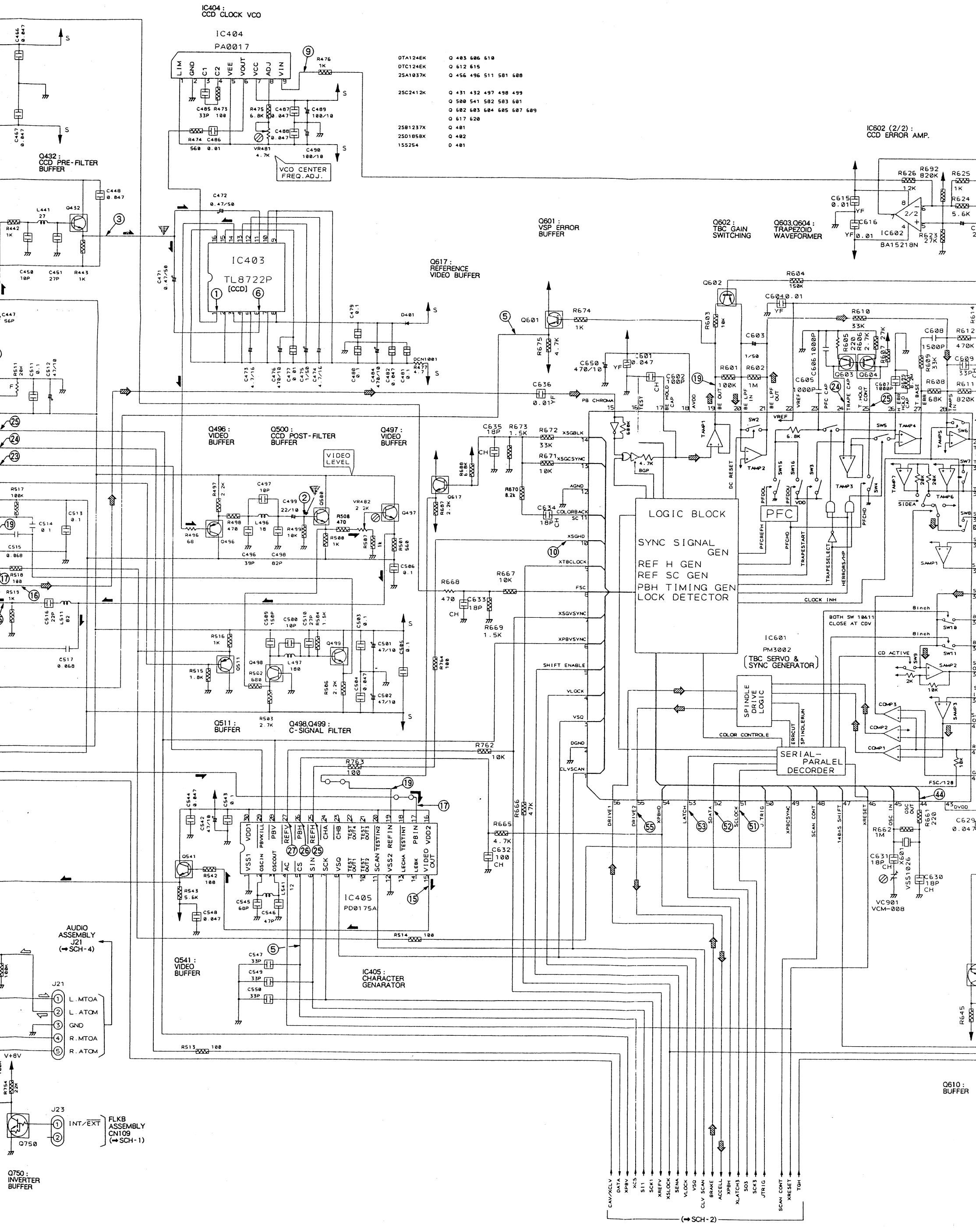

- DTA124EK Q 403 686 610
- DTC124EK Q 612 615
- 25A1037K Q 456 496 511 581 600
- 25C2412K Q 431 432 497 498 499
- Q 500 541 582 583 601
- Q 682 683 684 685 687 689
- Q 617 620
- 25B1237K Q 481
- 25D1058X Q 402
- 155254 Q 401

◆:RF Signal Route
 ⊞:Spindle Servo Loop Line
 ▲:Video Signal Route
 △:Audio Signal Route (L ch)
 △(MIC):Audio Signal Route (MIC)

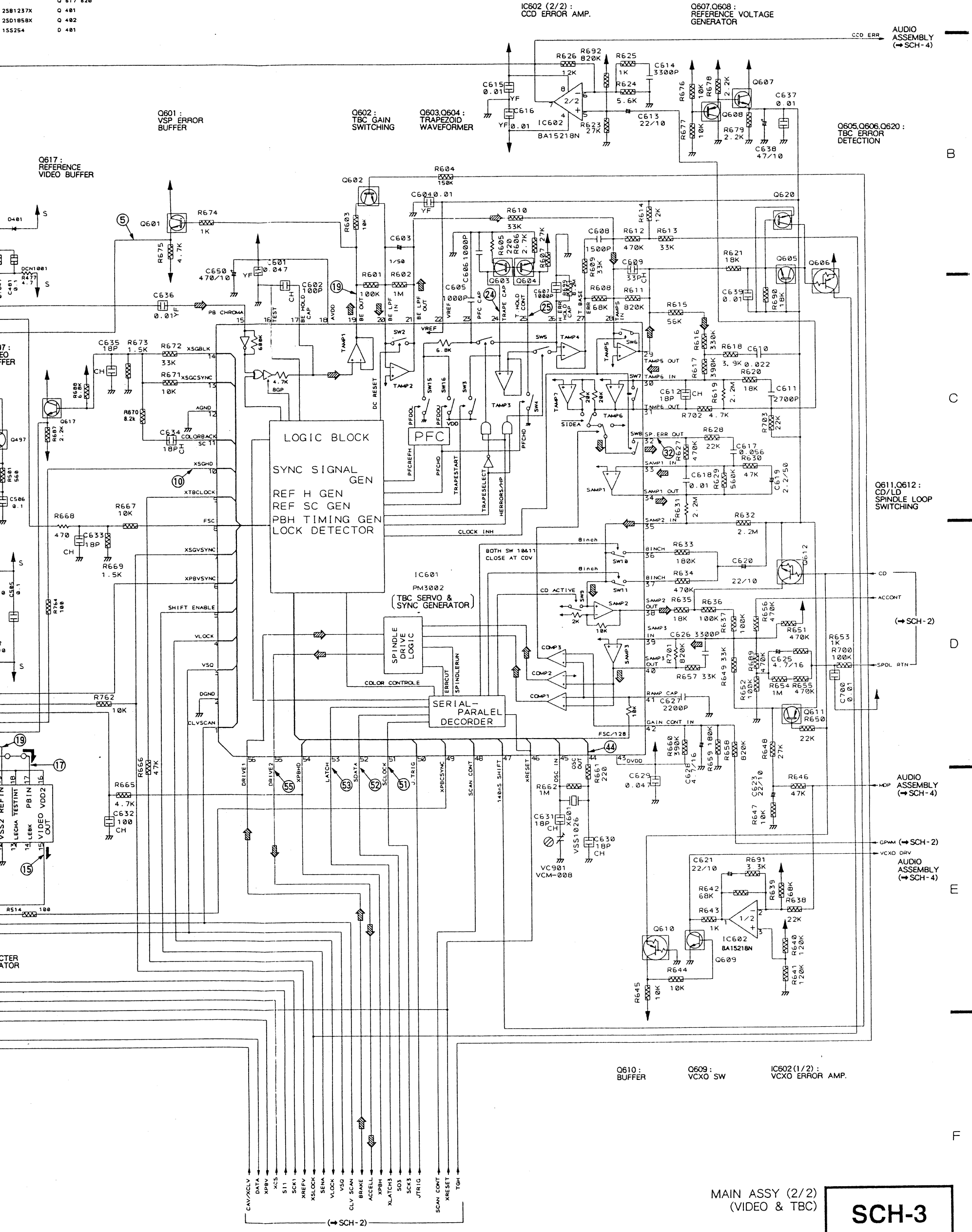

MAIN ASSY (2/2)
 (VIDEO & TBC)
SCH-3

● Waveforms
VIDEO AND TBC SECTION

Note: (No.) in the table correspond to the pin number.

Waveforms are at the PLAY mode.

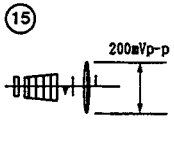
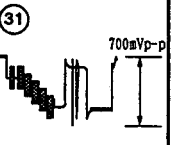
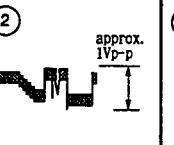
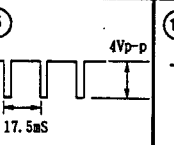
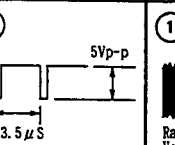
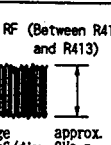
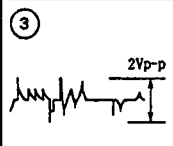
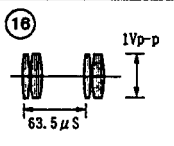
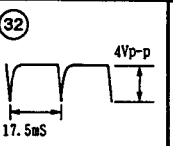
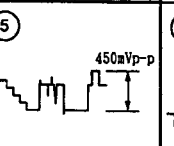
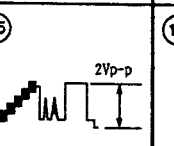
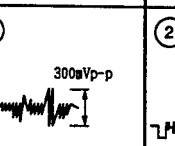
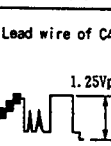
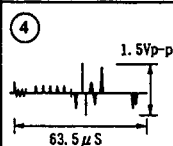
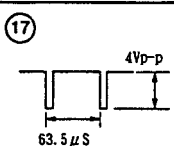
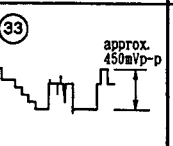
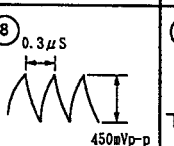
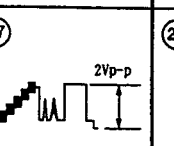
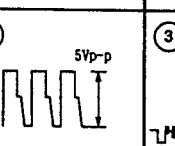
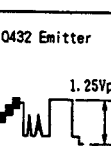
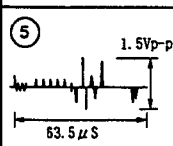
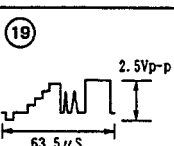
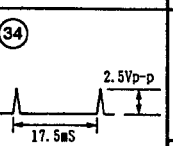
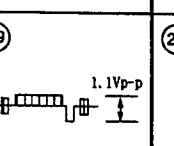
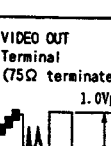
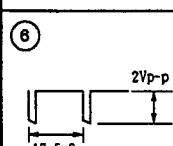
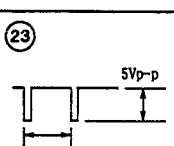
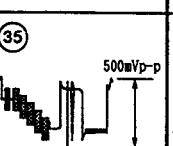
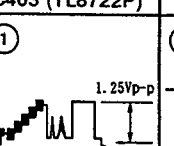
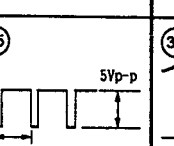
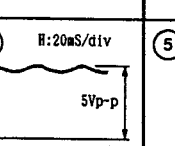
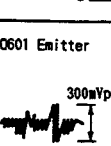
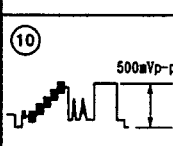
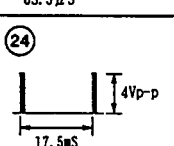
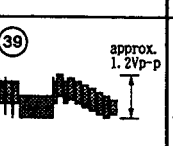
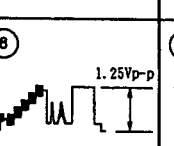
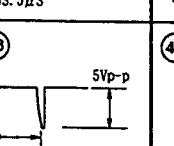
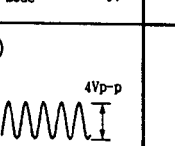
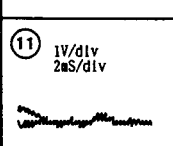
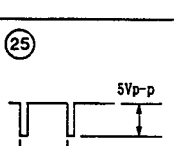
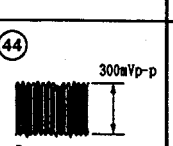
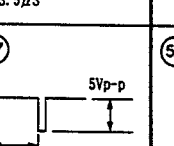
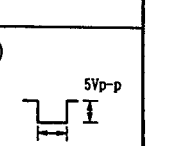
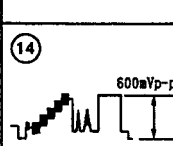
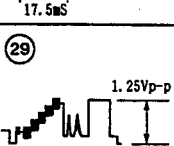
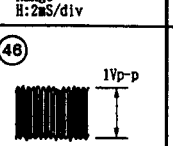
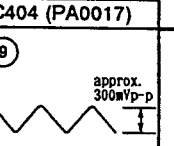
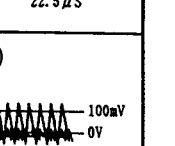
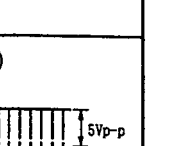
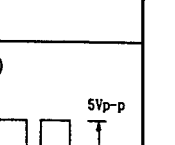
IC401 (PA5013A)			IC402 (PM0001)	IC405 (PD0175A)	IC601 (PM3002)	Others point
(1) 	(15) 	(31) 	(2) 	(5) 	(10) 	(1) RF (Between R411 and R413)  Range approx. H:2mS/div 2Vp-p
(3) 	(16) 	(32) 	(5) 	(15) 	(19) 	(2) Lead wire of C499 
(4) 	(17) 	(33) 	(8) 	(17) 	(24) 	(3) Q432 Emitter 
(5) 	(19) 	(34) 	IC403 (TL8722P)		(19) 	(4) VIDEO OUT Terminal (75Ω terminated) 
(6) 	(23) 	(35) 	(1) 	(25) 	(32) 	(5) 0601 Emitter 
(10) 	(24) 	(39) 	(6) 	(28) 	(44) 	
(11) 	(25) 	(44) 	IC404 (PA0017)		(27) 	(51) 
(14) 	(29) 	(46) 	(9) 		(52) 	
					(53) 	
					(55) 	

● Waveforms
AUDIO ASSEMBLY

Note: (No.) in the table correspond to the pin number.

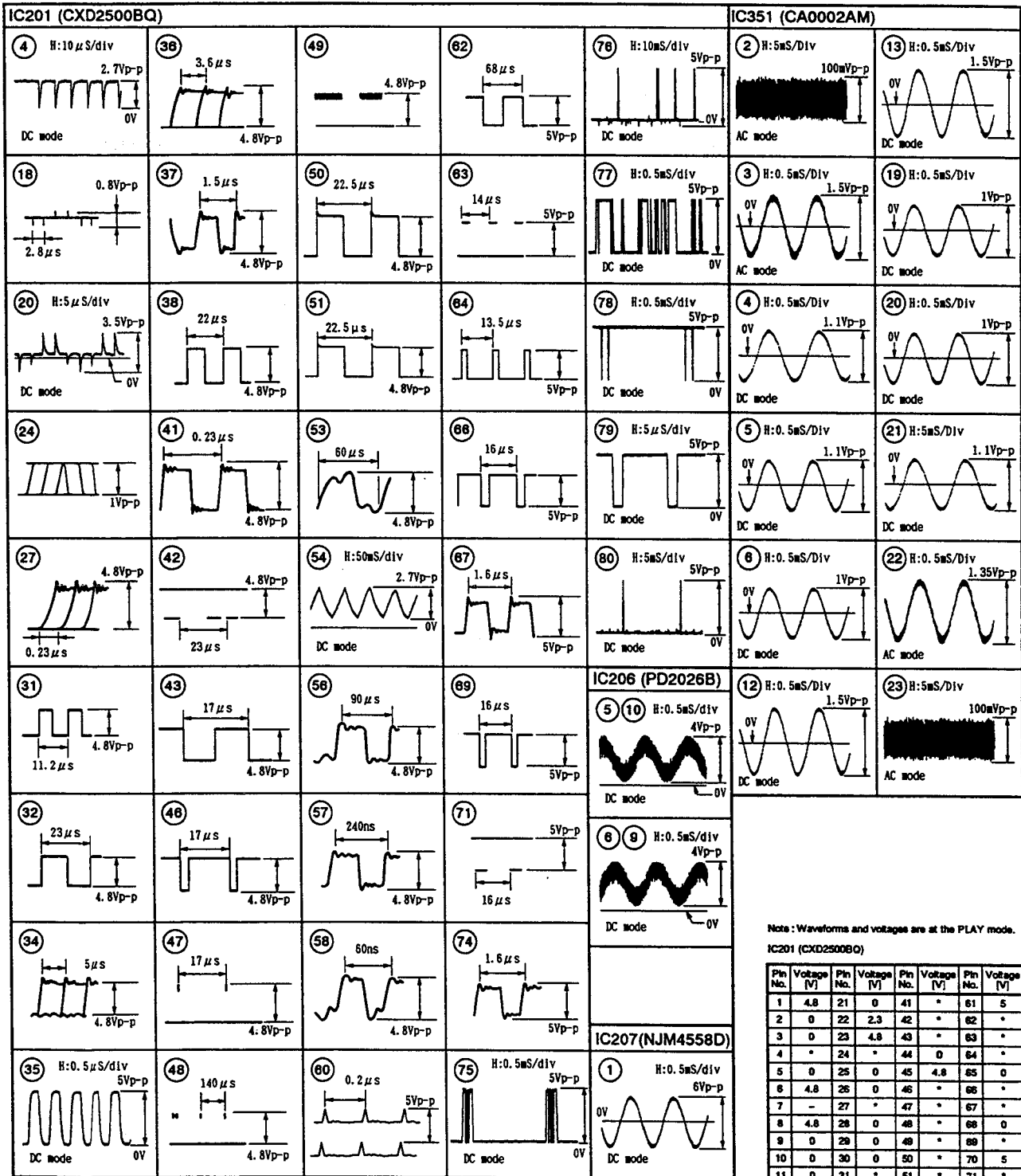

Note: Waveforms and voltages are at the PLAY mode.

IC201 (CXD2500BQ)

Pin No.	Voltage [V]	Pin No.	Voltage [V]	Pin No.	Voltage [V]	Pin No.	Voltage [V]
1	4.8	21	0	41	*	61	5
2	0	22	2.3	42	*	62	*
3	0	23	4.8	43	*	63	*
4	*	24	*	44	0	64	*
5	0	25	0	45	4.8	65	0
6	4.8	26	0	46	*	66	*
7	-	27	*	47	*	67	*
8	4.8	28	0	48	*	68	0
9	0	29	0	49	*	69	*
10	0	30	0	50	*	70	5
11	0	31	*	51	*	71	*
12	0	32	*	52	0	72	5
13	0	33	4.8	53	*	73	5
14	0	34	*	54	*	74	*
15	0	35	*	55	0	75	*
16	4.8	36	*	56	*	76	*
17	0	37	*	57	*	77	*
18	*	38	*	58	*	78	*
19	2.4	39	0	59	5	79	*
20	*	40	4.8	60	*	80	*

Note: Waveforms and voltages are at the PLAY mode.

IC351 (CA0002AM)

Pin No.	1	2	3	4	5	6	7	8	9	10	11	12
Voltage [V]	-5	*	*	*	*	*	0	0	0	+5	-2	*
Pin No.	13	14	15	16	17	18	19	20	21	22	23	24
Voltage [V]	*	-0.6	-0.6	0	0	+5	*	*	*	*	*	-2.2

*: Refer to waveform

*: Refer to waveform

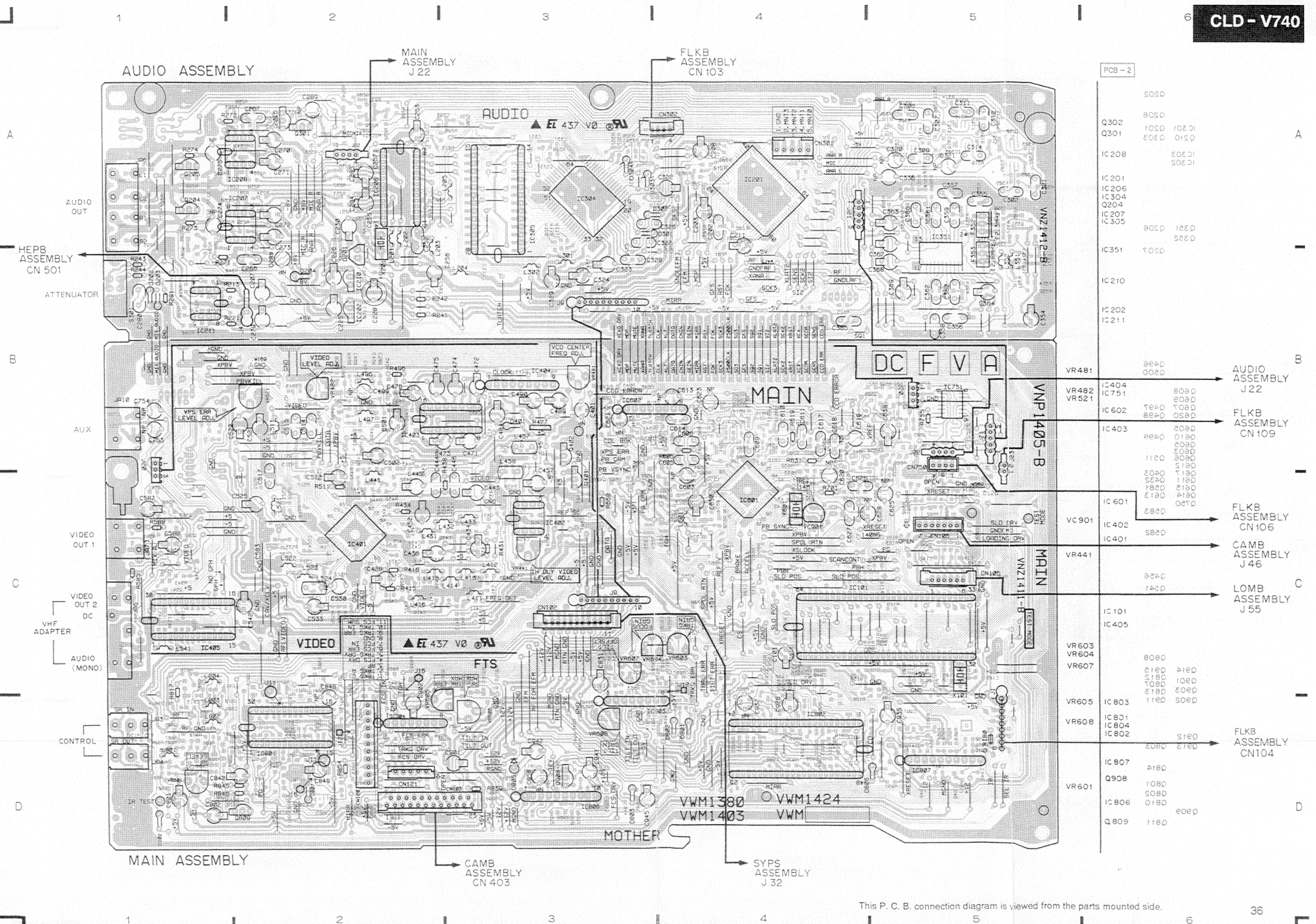

This P. C. B. connection diagram is viewed from the parts mounted side.

PCB - S	Part Number	Component
2020	IC301	IC 301
8200	IC302	IC 302
1020	IC303	IC 303
1020	IC304	IC 304
1020	IC305	IC 305
1020	IC306	IC 306
1020	IC307	IC 307
1020	IC308	IC 308
1020	IC309	IC 309
1020	IC310	IC 310
1020	IC311	IC 311
0490	VR481	VR 481
0500	IC401	IC 401
0590	IC402	IC 402
0690	IC403	IC 403
0700	IC404	IC 404
0790	IC405	IC 405
0890	IC406	IC 406
0990	IC407	IC 407
1090	IC408	IC 408
1190	IC409	IC 409
1290	IC410	IC 410
1390	IC411	IC 411
1490	IC412	IC 412
1590	IC413	IC 413
1690	IC414	IC 414
1790	IC415	IC 415
1890	IC416	IC 416
1990	IC417	IC 417
2090	IC418	IC 418
2190	IC419	IC 419
2290	IC420	IC 420
0890	VR482	VR 482
0990	VR483	VR 483
1090	VR484	VR 484
1190	VR485	VR 485
1290	VR486	VR 486
1390	VR487	VR 487
1490	VR488	VR 488
1590	VR489	VR 489
1690	VR490	VR 490
1790	VR491	VR 491
1890	VR492	VR 492
1990	VR493	VR 493
2090	VR494	VR 494
2190	VR495	VR 495
2290	VR496	VR 496
0890	VR497	VR 497
0990	VR498	VR 498
1090	VR499	VR 499
1190	VR500	VR 500
1290	VR501	VR 501
1390	VR502	VR 502
1490	VR503	VR 503
1590	VR504	VR 504
1690	VR505	VR 505
1790	VR506	VR 506
1890	VR507	VR 507
1990	VR508	VR 508
2090	VR509	VR 509
2190	VR510	VR 510
2290	VR511	VR 511

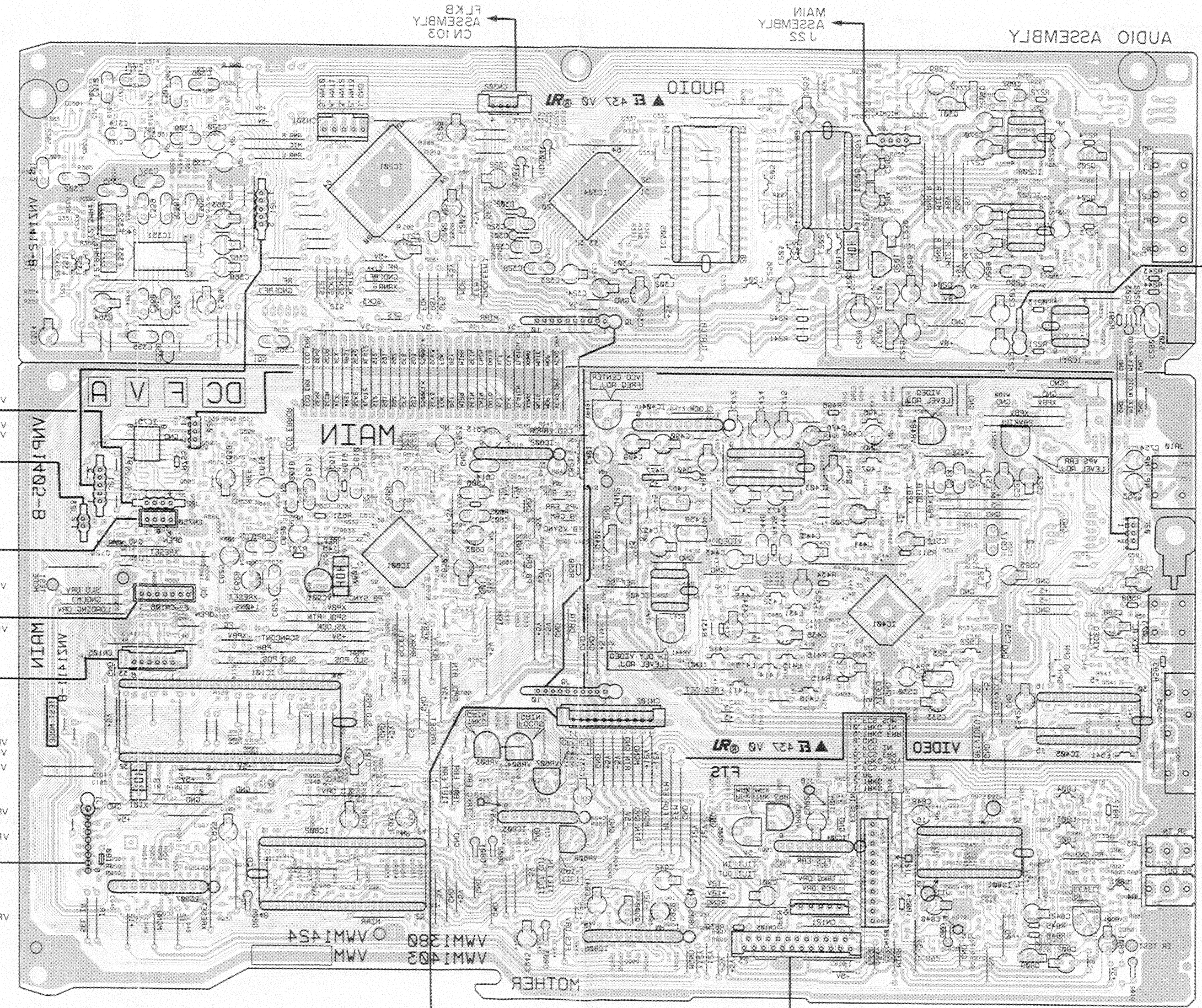

This P. C. B. connection diagram is viewed from the foil side.

3.4 AUDIO ASSEMBLY

CLD - V740

SCH-4

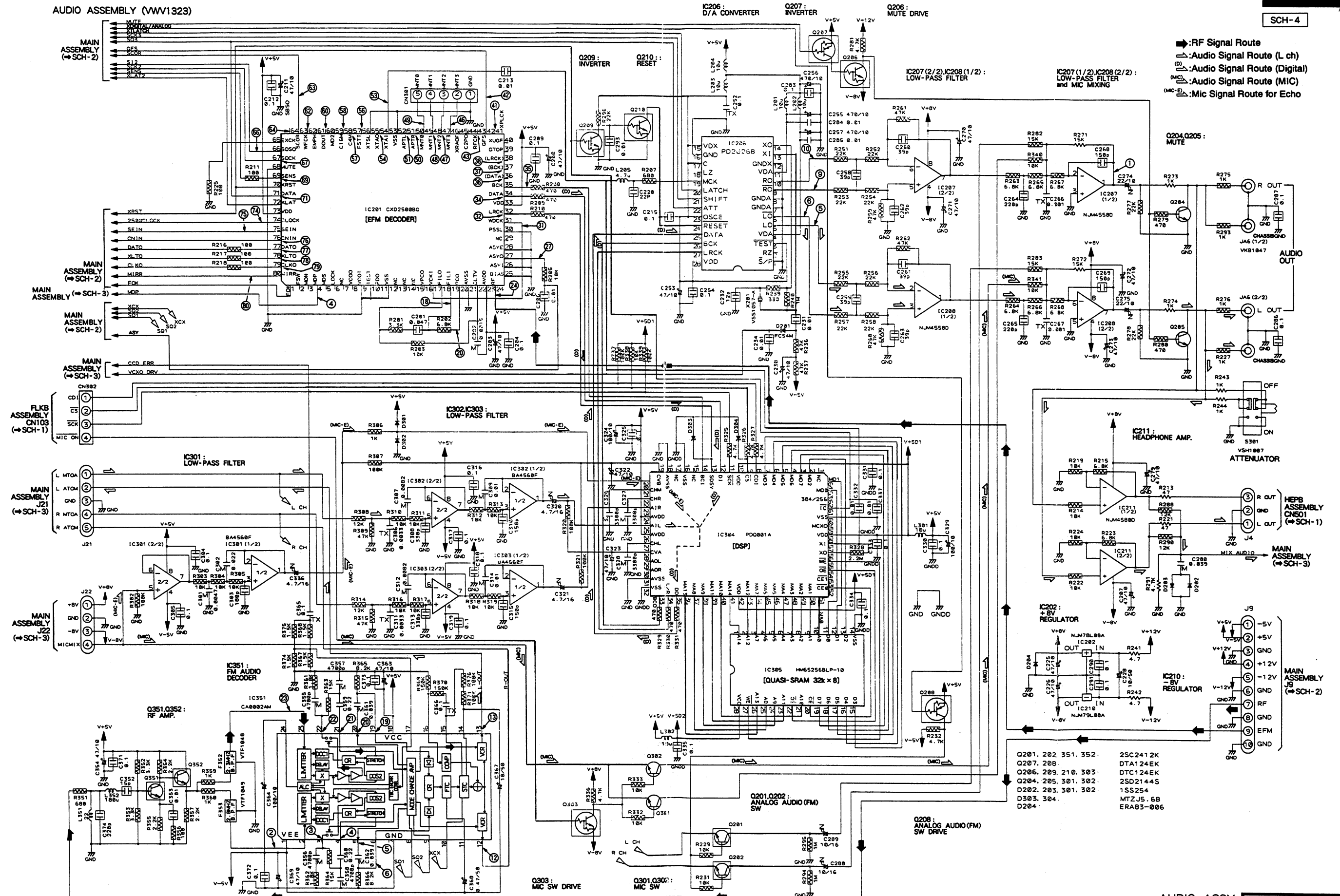

— RF Signal Route
 - - - Audio Signal Route (L ch)
 ····· Audio Signal Route (Digital)
 - · - · Audio Signal Route (MIC)
 - - - - Mic Signal Route for Echo

Q201, 202	351, 352	2SC2412K
Q207, 208		DTA124EK
Q206, 209, 210, 303		DTC124EK
Q204, 205, 301, 302		2SD2144S
D202, 203, 301, 302		15S254
D303, 304		MTZJ5.6B
D204		ERAB3-006

AUDIO ASSY

AUDIO ASSY

SCH-4

SCH-4

4. PCB PARTS LIST

NOTES:

- Parts marked by "NSP" are generally unavailable because they are not in our Master Spare Parts List.
- The Δ mark found on some component parts indicates the importance of the safety factor of the part. Therefore, when replacing, be sure to use parts of identical designation.
- Parts marked by "⊙" are not always kept in stock. Their delivery time may be longer than usual or they may be unavailable.
- When ordering resistors, first convert resistance values into code form as shown in the following examples.

Ex.1 When there are 2 effective digits (any digit apart from 0), such as 560 ohm and 47k ohm (tolerance is shown by J=5%, and K=10%).

560 Ω \rightarrow 56 \times 10¹ \rightarrow 561 RD1/8PM $\boxed{561J}$

47k Ω \rightarrow 47 \times 10³ \rightarrow 473 RD1/4PS $\boxed{473J}$

0.5 Ω \rightarrow 0R5 RN2H $\boxed{0R5K}$

1 Ω \rightarrow 010 RSIP $\boxed{010K}$

Ex.2 When there are 3 effective digits (such as in high precision metal film resistors).

5.62k Ω \rightarrow 562 \times 10¹ \rightarrow 5621 RN1/4PC $\boxed{5621F}$

Mark No.	Description	Part No.	Mark No.	Description	Part No.
LIST OF ASSEMBLIES					
⊙	FRPB ASSEMBLY	VWM1402	FLKB ASSEMBLY		
NSP	IRKB ASSEMBLY	VWG1435	SEMICONDUCTORS		
NSP	FDKB ASSEMBLY	VWG1436	IC103	NJM4558D	
NSP	SDKB ASSEMBLY	VWG1437	IC101	PD3244A	
NSP	FLKB ASSEMBLY	VWG1450	IC102	PST529D	
NSP	MIJB ASSEMBLY	VVV1303	Q102	DTA144ES	
NSP	HEPB ASSEMBLY	VVV1304	Q101, Q103-Q106	DTC124ES	
⊙	MOTHER ASSEMBLY	VWM1403	D101-D106, D111	1SS252	
NSP	AUDIO ASSEMBLY	VVV1323	D117	SEL3410ELC05	
NSP	MAIN ASSEMBLY	VWX1191	D112, D114, D116	VEL1017	
⊙	SYPS ASSEMBLY	VWR1160	SWITCHES		
⊙	MACB ASSEMBLY	VWM1250	S101-S113	RSG1030	
NSP	FG ASSEMBLY	VWG1304	COIL		
NSP	PKSB ASSEMBLY	VWG1305	L101	LAU010K	
NSP	CAMB ASSEMBLY	VWG1306	CAPACITORS		
NSP	LOSB ASSEMBLY	VWG1307	C120	CCCC330J50	
NSP	LOMB ASSEMBLY	VWG1308	C105	CEAL100M16	
			C101	CEAL100M50	
			C103	CEAL101MGR3	
			C113, C114	CEJA100M16	
			C109	CFTXA683J50	
			C110	CKPUYB101K50	
			C106	CKPUYB102K50	
			C102, C104	CKPUYF223Z25	
			C107, C108, C111, C112	CKPUY103N16	
			RESISTORS		
			VR101-VR104	VCS1027	
			R108	RA5T104J	
			R110	RA7T103J	
			Other resistors	RD1/6PM□□□□	
			OTHERS		
			CN103 2mm PITCH BOTTOM CONNECTOR	BTMK04S	
			CN107 2mm PITCH BOTTOM CONNECTOR	BTMK05S	
			CN101 2mm PITCH BOTTOM CONNECTOR	BTMK06S	
			CN102 2mm PITCH BOTTOM CONNECTOR	BTMK08S	
			CN105 2mm PITCH BOTTOM CONNECTOR	BTMK09S	
			V101 FL INDICATOR	VAV1029	
			SPACER	VEC1599	
			FL HOLDER	VNF1078	
			X101 CERAMIC RESONATOR (8MHz)	VSS1031	
			IRKB ASSEMBLY		
			SWITCH		
			S401	RSG1030	
			OTHERS		
			REMOTE SENSOR	GP1U58X	
			FDKB ASSEMBLY		
			SWITCHES		
			S301-S310	RSG1030	
			SDKB ASSEMBLY		
			SWITCHES		
			S201-S210	RSG1030	

Mark No.	Description	Part No.	Mark No.	Description	Part No.
MIJB ASSEMBLY					
SEMICONDUCTOR					
IC601		NJM2068D	COILS AND FILTERS		
CAPACITORS					
C604, C610	CEJA2R2M50		L201-L204, L301, L302	LAU100J	
C612	CKCYF473Z50		L352	LAU181J	
C605, C611	CKPUYB681K50		L351	LAU220J	
C601, C602	CKPUYF223Z25		L205	LAU4R7K	
C606, C607	CKPUY103N16		F352	VTF1048	
C691, C692	CQMA104J50		F353	VTF1049	
C603, C609	CQMA152J50		CAPACITORS		
RESISTORS					
All resistors		RD1/6PM□□□□	C352	CCSQCH150J50	
OTHERS					
JA601, JA603 HEADPHONE JACK	RKB1014		C268, C269, C310, C315	CCSQCH151J50	
JA602 HEADPHONE JACK	RKN1006		C232	CCSQCH180J50	
SNAP PLATE	VNE1102		C303	CCSQCH181J50	
JACK HOLDER	VNE1822		C220	CCSQCH220J50	
HEPB ASSEMBLY					
RESISTOR					
VR501	VCS1020		C264, C265, C374	CCSQCH221J50	
CAPACITORS					
C503	CKCYF473Z50		C308, C313	CCSQCH331J50	
C501, C502	CKPUYB101K50		C258-C263	CCSQCH390J50	
OTHERS					
JA501 HEADPHONE JACK	RKN1002		C288, C289	CEANP100M16	
AUDIO ASSEMBLY					
SEMICONDUCTORS					
IC301-IC303	BA4560F		C274, C275	CEANP220M10	
IC351	CA0002AM		C324, C329, C364	CEAS101M10	
IC201	CXD2500BQ		C203, C207, C208, C211, C225, C226,	CEAS470M10	
IC305	HM65256BLP-10		C230, C253, C270-C273, C279, C322,		
IC207, IC208	NJM4558D		C323, C354, C363, C369		
IC211	NJM4580D		C228, C367	CEHAQ100M50	
IC202	NJM78L08A		C320, C321, C336	CEJANP4R7M16	
IC210	NJM79L08A		C368	CEJAR47M50	
IC206	PD2026B		C266, C267	CFTXA102J50	
IC304	PDQ001A		C252, C365, C366	CFTXA104J50	
Q201, Q202, Q351, Q352	2SC2412K		C202	CFTXA152J50	
Q204, Q205, Q301, Q302	2SD2144S		C306, C311, C326-C328	CFTXA332J50	
Q207, Q208	DTA124EK		C280, C361, C362	CFTXA393J50	
Q206, Q209, Q210, Q303	DTC124EK		C309, C314	CFTYA103J50	
D202, D203, D301, D302	1SS254		C302	CFTYA223J50	
D204	ERA83-006		C359, C360	CFTYA224J50	
D201	FC54M		C284, C285	CKPUY103N16	
D303, D304	MTZJ5.6B		C206, C213, C231, C234, C293, C332,	CKSQYF103Z50	
SWITCH					
S301	VSH1007		C337, C353		
RESISTORS					
			C204, C209, C212, C215, C254, C283, C286,	CKSQYF104Z25	
			C287, C290, C291, C304, C305, C316-C319,		
			C325, C330, C331, C333-C335, C371-C373		
			C201	CKSQYF473Z25	
			C301, C355-C358	CQMA472J50	
			C307, C312	CQMA822J50	
			C255-C257	VCH1116	
			RESISTORS		
			R243, R244, R273, R274	RD1/6PM102J	
			R271, R272	RD1/6PM153J	
			R213, R221	RD1/6PM470J	
			R291	RD1/6PM472J	
			R241, R242	RD1/6PM4R7J	
			Other resistors	RS1/10S□□□□	
			OTHERS		
			CN301 5P TOP POST	B5P-SHF	
			3P CABLE HOLDER	51048-0300	
			JA6 4P PIN JACK	VKB1047	
			X201 CRYSTAL RESONATOR (16MHz)	VSS1057	

Mark No.	Description	Part No.
MAIN ASSEMBLY		
SEMICONDUCTORS		
IC805		BA10393F
IC602, IC804		BA15218N
IC750		BA4560F
IC751		BU4053BF
IC801		CXA1081S
IC802		CXA1372S
IC807		LA6510L
IC803		NJM072L
IC404		PA0017
IC401		PA5013A
IC101		PD0133C
IC405		PD0175A
IC402		PM0001
IC601		PM3002
IC806		TA8464K
IC403		TL8722P
Q456, Q496, Q511, Q581, Q608, Q611, Q613, Q614, Q802, Q812, Q909		2SA1037K
Q809		2SA1399
Q401		2SB1237X
Q431, Q432, Q497-Q500, Q541, Q582, Q583, Q601-Q605, Q607, Q609, Q617, Q620, Q801, Q803-Q805, Q807, Q811, Q813, Q915		2SC2412K
Q402		2SD1858X
Q908		2SK184
Q403, Q606, Q610, Q808, Q810, Q814, Q903, Q913		DTA124EK
Q612, Q615, Q750, Q901, Q902, Q911, Q912, Q914		DTC124EK
D805		1SR35-100AVL
D102, D401, D801-D803, D806, D807		1SS254
D810, D811		DA204K
COILS		
L414, L415, L521, L541		LAU120J
L801		LAU150J
L802, L804		LAU151J
L496		LAU180J
L497, L803		LAU181J
L412, L413, L523		LAU220J
L441		LAU270J
L411, L416		LAU330J
L433		LAU390J
L431		LAU430J
L522		LAU560J
L432		LAU620J
L511		LAU820J
L458		LFA221J
L457, L524		LFA561J

Mark No.	Description	Part No.
CAPACITORS		
C816, C844		CCSQCH050C50
C441		CCSQCH070D50
C438, C450, C497, C500		CCSQCH100D50
C461, C528, C602, C632, C809, C811		CCSQCH101J50
C418		CCSQCH120J50
C456		CCSQCH121J50
C413, C509		CCSQCH151J50
C415, C417, C612, C630, C631, C633-C635		CCSQCH180J50
C423, C424, C516		CCSQCH220J50
C411, C414		CCSQCH221J50
C437, C451, C510, C810, C843		CCSQCH270J50
C463, C751, C752, C918, C930, C957		CCSQCH271J50
C104, C105, C462, C485, C547, C549, C550, C609		CCSQCH330J50
C416, C433, C440, C496, C524		CCSQCH390J50
C412, C419, C420, C439, C455, C546, C845, C846		CCSQCH470J50
C566, C841, C998, C999		CCSQCH471J50
C847		CCSQCH510J50
C447		CCSQCH560J50
C545, C806, C808, C812		CCSQCH680J50
C498		CCSQCH820J50
C529, C536		CCSQCH910J50
C603, C753, C754		CEANP010M50
C530, C848		CEANP100M16
C499, C613, C620, C621, C623		CEANP220M10
C401, C619		CEANP2R2M50
C436, C475, C945		CEAS010M50
C434, C445, C457, C489, C490, C842		CEAS101M10
C101, C428, C452, C501, C502, C512, C521, C525, C533, C542, C587, C588, C638, C801, C802, C901, C902		CEAS470M10
C476, C484		CEAS471M10
C522, C831, C941, C942		CEHAQ100M50
C443, C473, C474, C625, C628, C926, C932		CEJANP4R7M16
C471, C472, C849, C935		CEJAR47M50
C605, C606		CFTXA102J50
C446, C618		CFTXA103J50
C514		CFTXA104J50
C608		CFTXA152J50
C610		CFTXA223J50
C614, C626		CFTXA332J50
C617		CFTXA563J50
C515, C517		CFTXA683J50
C607, C832, C940, C944		CKSQYB102K50
C913, C925, C929, C936		CKSQYB333K25
C920, C923		CKSQYB562K50
C103, C106, C108, C109, C122, C140-C142, C425, C426, C458-C460, C477, C486, C532, C535, C567, C604, C615, C616, C636, C637, C639, C700, C755, C756, C803, C804, C807, C814, C817, C818, C850, C855-C857, C904, C914, C915, C917, C928, C931, C933, C934, C937-C939, C946, C950, C997		CKSQYF103Z50

Mark	No.	Description	Part No.
	C107, C403, C404, C429, C435, C442, C479, C480, C481, C503, C505, C506, C511, C513, C526, C531, C543, C584, C586, C805, C813, C911, C912, C919, C922, C924, C927, C947, C952, C959		CKSQYF104Z25
	C102, C407, C408, C427, C448, C466, C467, C482, C487, C488, C504, C527, C544, C548, C601, C629, C815, C943, C948, C949, C951, C956, C627		CKSQYF473Z25 CQMA222J50
	C444, C611, C958, C650, VC901		CQMA272J50 VCH1115 VCH1116 VCM-008
RESISTORS	VR601, VR481, VR521, VR441, VR606, VR608, VR482, VR605, VR603, VR604, VR607, R477, R755, R605, R817, R619, R631, R854, R845, R846, R668, R431, R496, R585, R588, R701, R438, R511, R415, R416, R434, Other resistors		RCP1019 RCP1020 RCP1046 VCP1062 VRTB6VS153 VRTB6VS222 VRTB6VS333 VRTB6VS473 DCN1001 RD1/6PM103J RD1/6PM221J RD1/6PM225J RD1/6PM470J RD1/6PM471J RD1/6PM510J RD1/6PM680J RD1/6PM750J RD1/6PM824J RN1/6PQ1203F RN1/6PQ2002F RN1/6PQ2402F RN1/6PQ5101F RS1/10S□□□J
OTHERS	CN120 11P TOP POST, CN121 5P TOP POST, CN106 KR CONNECTOR, CN103 FFC CONNECTOR (23P), CN105 2mm PITCH JUMPER CONNECTOR, 9P CABLE HOLDER, JA3, JA4 REMOTE CONTROL JACK, PCB BINDER, JA5 RF PIN JACK, JA7 1P PIN JACK, JA10 2P PIN JACK, SCREW TERMINAL, EARTH PLATE, X601 CRYSTAL RESONATOR (14.318MHz), X101 CERAMIC RESONATOR (9MHz)		B11P-SHF-1AA B5B-EH B7B-PH-K HLEM23S SBRK06S 51048-0900 PKN1004 VEF1040 VKB1029 VKB1048 VKB1060 VNE1841 VNF-091 VSS1026 VSS1040

Mark	No.	Description	Part No.
SYPS ASSEMBLY			
SEMICONDUCTORS			
△		IC201, IC202, IC204	ICP-N15
△		IC203	ICP-N20
△		IC2	NJM4558D
△		IC1	NJM78M05FA
		Q5, Q22, Q23	2SA933S
△		Q1, Q2, Q25, Q27	2SB1185
		Q4, Q21, Q24	2SC1740S
△		Q3, Q26, Q28	2SD1762
△		D23, D26	10ELS2
△		D3, D33	11ES2
△		D24, D25	1SR35-100AVL
△		D21, D22	1SS254
△		D2	ERA83-006
		D7	MTZJ11B
△		D1	S2VB20
COIL			
△		L1	L1043
CAPACITORS			
		C10, C29	CEAS101M50
		C13	CEAS102M16
		C25, C26	CEAS2R2M50
		C3-C6	CEAS470M10
△		C14	CGCYX473M25
		C23, C24	CGCYX473M25
		C11, C12	CKPUYF103Z25
△		C7-C9	CKPUYF223Z25
		C27, C28	CQMA223J50
		C21, C22	CQMA272J50
△		C52	RCG-009
△		C2	VCH1053
△		C1	VCH1054
RESISTORS			
△		R27-R30	DCN1003
△		R51	RD1/2PM225J
△		R23-R26	RD1/2VM221J
		Other resistors	RD1/6PM□□□J
OTHERS			
		CN31 KR CONNECTOR	B2B-PH-K
		6P CABLE HOLDER	51048-0600
		12P CABLE HOLDER	51048-1200
△		PCB BINDER	VEF1040
		POWER SUPPLY TERMINAL	VKC-019
△		FUSE HOLDER	VKR1001
△		SCREW TERMINAL	VNE1646
FG ASSEMBLY			
SEMICONDUCTOR			
		D1	GP1S51V
OTHERS			
		HOUSING ASSEMBLY	VKP1950

<u>Mark No.</u>	<u>Description</u>	<u>Part No.</u>
PKSB ASSEMBLY		
SWITCHES		
S4, S5		DSG1015
OTHERS		
	HOUSING ASSEMBLY	VKP1951
CAMB ASSEMBLY		
SEMICONDUCTOR		
Q10		2SC1740S
RESISTORS		
R10		RD1/6PM182J
R11		RD1/6PM470J
OTHERS		
CN404	KR CONNECTOR 3P	B3B-PH-K
CN402	KR CONNECTOR	B3B-PH-K-R
CN403	FFC CONNECTOR 23P	HLEM23R
CN401	23P TOP CONNECTOR	VKN1073
	HOUSING ASSEMBLY	VKP1949
LOSB ASSEMBLY		
SWITCHES		
S1-S3		DSG1015
LOMB ASSEMBLY		
CAPACITOR		
C1		CGCYX473M25
OTHERS		
J51	2mm PITCH JUMPER 4P	D20PWW0415G
J55	2mm PITCH JUMPER 6P	D20PWW0615G

5. ADJUSTMENTS

(1) PRELIMINARIES

• Jigs for Adjustment

- CD test disc (STD - 901 or STD - 902)
- LD test disc (GGV1003)
- (-) screwdriver (medium)
- (-) screwdriver (small)
- Hexagonal wrench driver (straight type, size: 3mm)
- Resistors (10kΩ × 2, 47kΩ)
- Dual - trace oscilloscope (with delay)
- AF oscillator
- Frequency counter
- TV monitor
- Low-pass filter

Use the low-pass filters below in the coarse centering adjustment 2. and fine centering adjustment 6. when the S/N of the waveform is hard to observe.

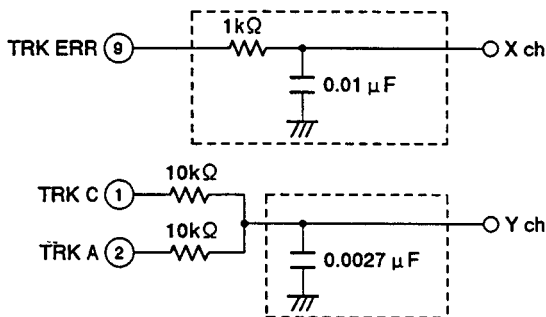

• Rack Assembly During Centering Adjustment

The S - IN position (without hitting the mechanism stopper) of the rack assembly during centering adjustment is indicated below.

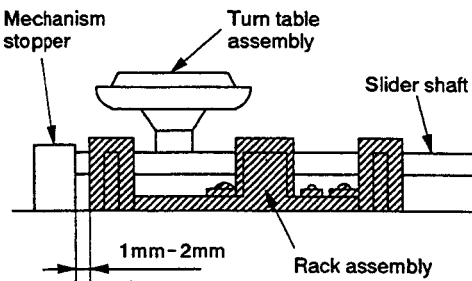

Fig. 1 Right side view

• Adjustment Locations

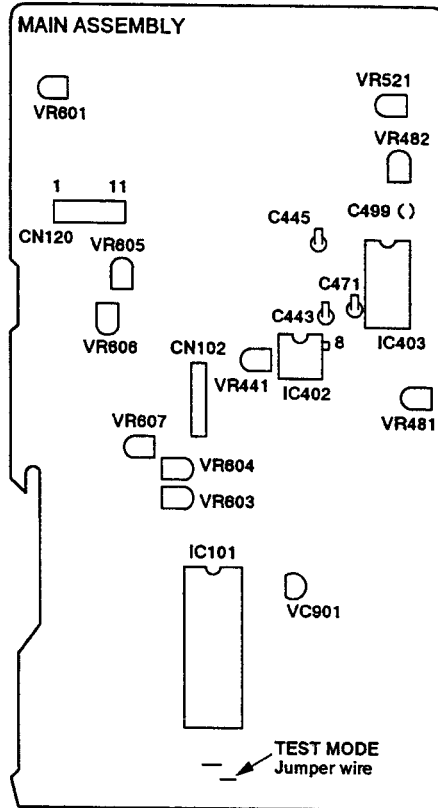
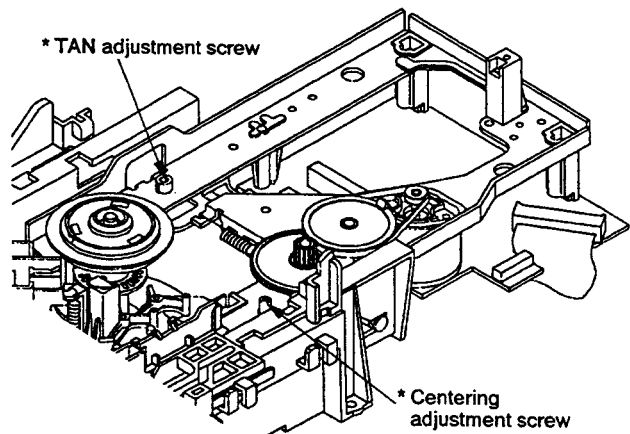

Fig. 2 MAIN assembly section



* : As the adjustment range of both the TAN and centering adjustment screws is only $\pm 90^\circ$ from the center, do not turn the screws beyond this range.

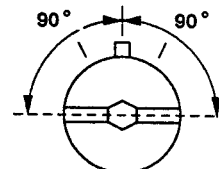

Fig. 3 TILT base section

• Test Mode

1) Activating the Test Mode

1. While power is ON, connect the Test mode jumper wire (Fig. 2) to the GND for about one second.
2. After checking whether the FL display device is fully lit, disconnect the Test mode jumper wire from GND.

2) Canceling the Test Mode

1. Turn the power OFF.

• Key operation in the Test mode

Player Status	Key Operation	Function	Remarks
Tray Open	◀◀/▶▶ SKIP (Refer to Note 1)	◀◀: Shifts the tray in the closed direction and also raises the turn table while it is held down. ▶▶: Shifts the tray in the open direction and also lowers the turn table while it is held down.	
Tray Open	▶ Play	Clamps	
Clamp	▶ Play	Turns the disc through TRK Servo Open	TRK-OFF
TRK Servo Open	▶ Play	TRK Servo Close	TRK-ON
TILT Neutral	+MULTI-SPEED or # (sharp)	TILT Servo Close	T-□:ON
TILT ON	-MULTI-SPEED or b (flat)	TILT Neutral	T-□:N
TILT Neutral or ON	◀◀/▶▶ SKIP	Setting TILT Servo to OFF, can force TILT to move.	T-1 to T-E
Clamp	◀◀/▶▶ SCAN	Can force the slider to move	S-LD S-CDV S-CD S-IN
Play	PAUSE	Still	
Play	■ STOP	Stop	
Stop	▲ OPEN	Open	
Play	<div style="text-align: center;"> +10 ↓ 0 to 9 ↓ ▶ PLAY </div>	Set to SEARCH lead address input mode. Designates the SEARCH lead address through keys 0 to 9. Press the CLEAR [C] key if the designated address is incorrect. Searches the designated address upon pressing the PLAY key.	

Note 1: Press SKIP (|◀◀/▶▶|) keys after the tray is set to open state by pressing OPEN (▲) key.
In tray open state, pressing PLAY (▶) key causes is to TILT control state and SKIP keys cannot function properly.

• **Player Operation in the Test Mode**

Operate the player by selecting a test mode function with the keys on the player or on the remote control unit.

• **CD PLAYBACK**

- ① Place the CD disc on the turn table.

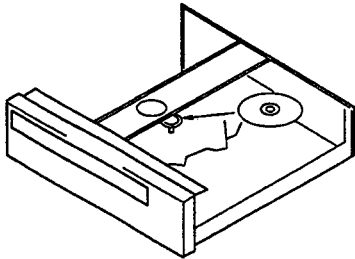

- ② Press the PLAY (▶) key once.
(Twin gear starts to move.)
- ③ Push the cam plate (Fig. 4) in the direction of the arrow and wait until the CD disc is clamped.

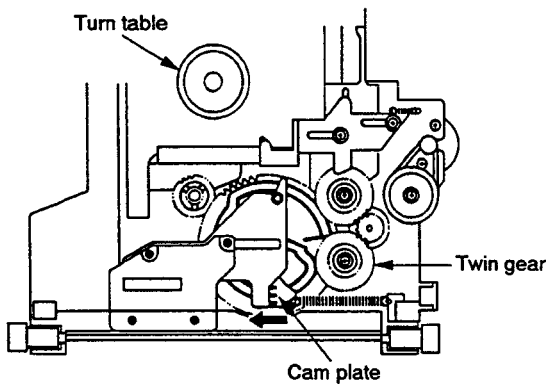
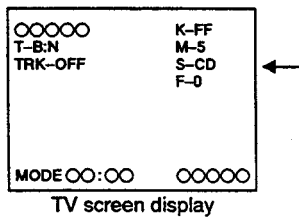

Fig. 4

- ④ Press the ◀◀ or ▶▶ keys to appear "S - CD" on the TV screen display.



- ⑤ Press the PLAY (▶) key twice, disc will be normally playbacked.

• **LD PLAYBACK**

- ① Place the LD disc on the turn table.

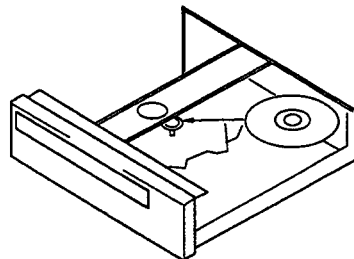

- ② Press the PLAY (▶) key once. (Twin gear starts to move.)
- ③ Press the SKIP REV (◀◀) key to raise the turn table (spindle motor section) while pressing the cam plate (Fig. 4) in the direction of the arrow. Raise it to the position where the LD disc can be easily placed on the turn table. If the turn table is raised too high, lower it with the SKIP FWD (▶▶) key.
- ④ Place the LD disc on the turn table and press the PLAY (▶) key once to clamp the disc.
- ⑤ Press the ◀◀ or ▶▶ keys to appear "S - LD" on the TV screen display.

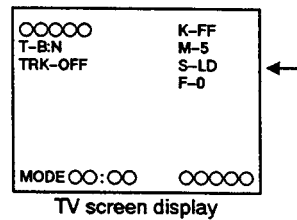

- ⑥ Press the PLAY (▶) key twice, disc will be normally playbacked.

(2) ADJUSTMENT TABLE

Adjustment name	Adjustment point	Measuring equipment and jigs	Measurement point	Player condition	Adjustment procedure	Waveform and connection diagram
1 Tilt Offset Check and Adjustment	VR607	• TV monitor	Tilt indication on Test mode screen	• Power ON • Test mode • Disc not installed	1. Check if the tilt indication on the Test mode screen is at T-6 to T-8. 2. If the tilt indication is not at T-6 to T-8, adjust VR607 until the tilt indication reaches T-6 to T-8.	
2 Coarse centering adjustment	Tilt base centering adjustment screw	• Oscilloscope • STD-901 or STD-902 • MIX resistor 	CN120 X: ⑨ Pin (TRK ERR) Y: ①+② Pin (TRK SUM)	• Test mode TRK Servo Open Tilt Servo ON • Innermost track of STD-901 or STD-902 which does not come in contact with the mechanical stopper.	1. Move the slider until it does not come in contact with the mechanical stopper at the slider position indication S-IN. 2. Observe TRK ERR (Xch) and TRK SUM (Ych) at the X-Y mode during TRK Servo Open. 3. Turn the centering adjustment screw until the Lissajous figure is horizontal.	
3 FCS balance adjustment (1) TRK ERR MAX	VR605	• Oscilloscope • STD-901 or STD-902	CN120 ⑨ Pin (TRK ERR)	• Test mode TRK Servo Open Tilt Servo ON • Inner track of STD-901 or STD-902	1. Observe TRK ERR at CH1 of the oscilloscope during TRK Servo Open. 2. Adjust VR605 until the amplitude of the waveform reaches its maximum.	
4 FCS balance adjustment (2) RF MAX	VR606	• Oscilloscope • STD-901 or STD-902	CN120 ③ Pin (RF)	• Test mode TRK Servo Close Tilt Servo ON • Inner track of STD-901 or STD-902	1. Close the TRK Servo and observe RF at CH1 of the oscilloscope. 2. Adjust VR606 until the amplitude of the waveform reaches its maximum and the envelope is very clear.	
5 Tangential direction angle adjustment	Tilt base TAN adjustment screw	• Oscilloscope • STD-901 or STD-902	CN120 ③ Pin (RF)	• Test mode TRK Servo Close Tilt Servo ON • Inner track of STD-901 or STD-902	1. Observe RF at CH1 of the oscilloscope during TRK Servo Close. 2. Adjust the TAN adjustment screw until the amplitude of the waveform reaches its maximum and the envelope is very clear.	
6 Fine centering adjustment	Tilt base Centering adjustment screw	• Oscilloscope • STD-901 or STD-902	CN120 X: ⑨ Pin (TRK ERR) Y: ①+② Pin (TRK SUM)	• Test mode TRK Servo Open Tilt Servo ON • Innermost track of STD-901 or STD-902 which does not come in contact with the mechanical stopper.	Perform fine centering adjustment by following the same procedure as in "(2) Coarse centering adjustment".	
Crosstalk check and Tilt offset adjustment	VR607	• TV monitor • GGV1003	Crosstalk check screen	• Test mode TRK Servo Close Tilt Servo ON • GGV1003 #115 STILL	1. Search for address 115 of GGV1003 and still the address. 2. Check the crosstalk. If the crosstalk is pronounced, adjust VR607 until the crosstalk is not noticeable.	
7	When the crosstalk is still noticeable in spite of the adjustment in (7), use a hexagonal wrench driver (straight type, size: 3 mm) to adjust the TAN adjustment screw on the bottom side of the player through the GGV1003 #115 STILL screen. Afterwards, perform the adjustment procedures from (6).					
8 FCS Servo loop gain adjustment	VR604	• Oscilloscope • GGV1003 • AF Oscillator • Resistor (47kΩ)	CN120 X: ⑦ Pin (FCS IN) Y: ⑥ Pin (FCS ERR)	• Test mode TRK Servo Close Tilt Servo ON • GGV1003 #15,000 STILL	1. Search for address 15,000 of GGV1003 and still the address. 2. Xch: Connect the resistor (47kΩ) to the channel and connect to FCS IN. Ych: Connect to FCS ERR. 3. Connect the AF oscillator between Xch and the 47kΩ resistor, and adjust VR604 until the Lissajous figure is symmetrical.	

Adjustment name	Adjustment point	Measuring equipment and jigs	Measurement point	Player condition	Adjustment procedure	Waveform and connection diagram
9 TRK Servo loop gain adjustment	VR603	<ul style="list-style-type: none"> Oscilloscope GGV1003 AF Oscillator Resistor (47kΩ) 	CN120 X: ⑩ Pin (TRK IN) Y: ⑨ Pin (TRK ERR)	<ul style="list-style-type: none"> Test mode Stop mode or TRK Servo Close Tilt Servo ON GGV1003 #15,000 STILL 	<ol style="list-style-type: none"> Xch: Connect the 47kΩ resistor to channel and connect to TRK IN. Ych: Connect to TRK ERR. Connect the AF oscillator between Xch and the 47kΩ resistor and note the tilt angle against the horizon with the disc in the stopped state. Search for address 15,000 of GGV1003 and still the address. Set the disc PLAY mode (TRK servo closed, TILT on). Adjust VR603 so that the tilt angle of the waveform will be the same as the tilt angle noted in step 3. 	
10 RF level adjustment	VR601	<ul style="list-style-type: none"> Oscilloscope GGV1003 	CN120 ③ Pin (RF)	<ul style="list-style-type: none"> Test mode TRK Servo Close Tilt Servo ON GGV1003 #15,000 STILL 	<ol style="list-style-type: none"> Search for address 15,000 of GGV1003 and still the address. Observe RF at CH1 of the oscilloscope. Adjust VR601 until the RF amplitude is 300mV ± 50mVp-p. 	
11 REF-H adjustment	VC901	<ul style="list-style-type: none"> Frequency counter 	IC402 (PM0001) ⑧ Pin	<ul style="list-style-type: none"> Power ON Stop mode 	Adjust FSC (3.579545 MHz) ± 10Hz.	
12 Video level adjustment	VR482	<ul style="list-style-type: none"> TV monitor Oscilloscope GGV1003 	Video output terminal	<ul style="list-style-type: none"> Normal mode GGV1003 #19,900 STILL 	Connect a 75Ω resistor to the VIDEO output terminal (possibly by connecting to the monitor) and adjust until the sync tip to 100% white level is 1Vp-p ± 5% at the composite TEST signal.	
13 1H DLY video level adjustment	VR441	<ul style="list-style-type: none"> Oscilloscope GGV1003 	CH1: C443 lead wire CH2: C445 lead wire	<ul style="list-style-type: none"> Normal mode GGV1003 #19,900 STILL 	Adjust until the sync tip to 100% white level at the composite TEST signal is the same as in CH1 and CH2.	
14 VCO center frequency adjustment	VR481	<ul style="list-style-type: none"> Oscilloscope GGV1003 	CH1: C471 lead wire CH2: C499 lead wire	<ul style="list-style-type: none"> Normal mode GGV1003 #5,100 STILL 	Place a trigger in CH1 and adjust until the center of the CH2 video signal jitter is 71 µsec (1H + 7.5 µsec) ± 0.2 µsec compared to the CH1 video signal.	
15 VPS error level adjustment	VR521	<ul style="list-style-type: none"> TV monitor GGV1003 	TV monitor	<ul style="list-style-type: none"> Normal mode GGV1003 #7,201 - #8,100 PLAY (Magenta screen) 	Adjust until the color irregularity on the magenta screen is minimized.	

6. FL INFORMATION

● VAW1029 (V101)

PIN LOCATION

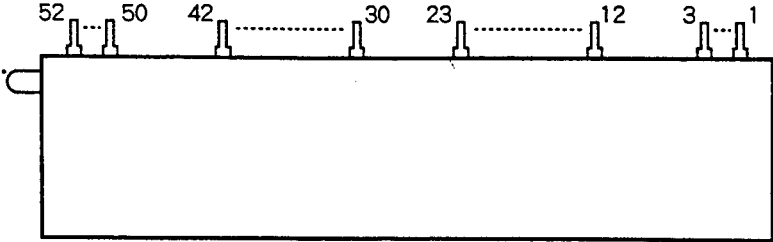

PIN ASSIGNMENT

Pin No.	1	2	3	4	5	6	7	8	9	10	11	12	13	14	15	16	17	18
Assignment	F	F	F	NP	NP	NP	NP	NP	NP	NP	NP	G12	G11	G10	G9	G8	G7	G6
Pin No.	19	20	21	22	23	24	25	26	27	28	29	30	31	32	33	34	35	36
Assignment	G5	G4	G3	G2	G1	NP	NP	NP	NP	NP	NP	a	b	c	d	e	f	g
Pin No.	37	38	39	40	41	42	43	44	45	46	47	48	49	50	51	52		
Assignment	h	i	j	k	l	m	NP	NP	NP	NP	NP	NP	NP	F	F	F		

F:Filament G1-G12:Grid a-m:Anode NP:No pin

ANODE GRID ASSIGNMENT & PIN ASSIGNMENT

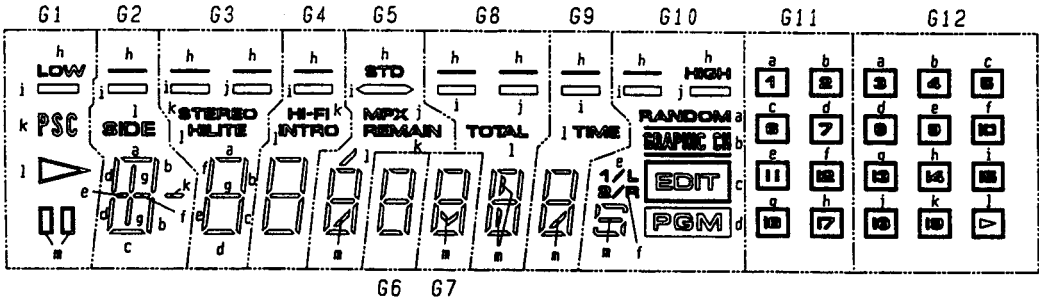

ANODE GRID ASSIGNMENT

	G1	G2	G3	G4	G5	G6	G7	G8	G9	G10	G11	G12
a	/	—	a	a	a	a	a	a	a	RANDOM	1	3
b	/		b	b	b	b	b	b	b	GRAPHIC CH	2	4
c	/	—	c	c	c	c	c	c	c	EDIT	8	6
d	/		d	d	d	d	d	d	d	PGM	7	8
e	/	—	e	e	e	e	e	e	e	1/L	11	9
f	/	—	f	f	f	f	f	f	f	2/R	12	10
g	/		g	g	g	g	g	g	g	/	10	13
h	LOW	—	—	—	STD	/	/	—	—	HIGH	7	14
i	—	—	—	—	/	/	/	—	—	—	/	15
j	/	/	—	/	MPX	/	/	—	—	—	/	16
k	PSC	—	STEREO	H-FI	REMAN	/	/	/	/	/	/	17
l	/	SIDE	HILITE	INTRO	/ (UP)	/	/	TOTAL	TIME	/	/	18
m	00	/	/	/	/ (LOW)	/	/	/	/	/	/	19

7. IC INFORMATION

- The information shown in the list is basic information and may not correspond exactly to that shown in the schematic diagrams.

■ PD3244A (IC101)

• Mode Control IC

• Pin Function

No.	Name	I/O	Function	No.	Name	I/O	Function
1	OEMSEL 1	I	L : PIONEER, H : Song interval production for OEM (Mic picture appears on the screen.)	41	G1	O	Display grid output
				42	G2		
				43	G3		
2	OEMSEL 2	I	L : PIONEER, H : Correspond to TEAC (Remote control unit)	44	G4		
				45	G5		
				46	G6		
3	P06	I	Not used (GND)	47	G7		
4	P07			48	G8		
5	AVSS	I	GND	49	G9		
6	TEST	I	Not used (GND)	50	G10		
7	X2	O	Not used (OPEN)	51	G11		
8	X1	I	Not used (GND)	52	G12		
9	VSS	I	GND	53	MODE1	O	MIC control terminal input 1
10	OSC1	I	Main system clock oscillation (8MHz)	54	MODE2	O	MIC control terminal input 2
11	OSC2	O					
12	xRESET IN	I	CPU reset. (L : reset)	55	KAR_NOR	O	Karaoke / Normal changeover switch input (H : Karaoke, L : Normal)
13	SHAKE	I	Serial communication requirement of the mechanism control.	56	P77	O	Not used (OPEN)
				57	VCC	I	+5V
14	SEL IR	I	Remote control input	58	KIN0	I	Key data input
15	DOGFOOD	O	Pulse output for watchdog.	59	KIN1		Not used (GND)
16	POWERON	O	Switching output of the mother board power supply.	60	KIN2		Key data input
				61	KIN3		
17	LED(ONETCH)	O	LED output : ONE - TOUCH KARAOKE indication.	62	KIN4		
18	LED(SURRND)	O	LED output : SURROUND indication.	63	KIN5		
19	P16	I	GND	64	KIN6		
20	P33	O	N.C. (OPEN)	65	KIN7		
21	LED(AUX_SEL)	O	LED output : AUX INPUT indication.	66	P90	O	
22	xMIC_ON	O	MIC audio ON/OFF switch (L : MIC active)	67	xS - CLOCK	I/O	Serial communication clock (Mechanism control, Character generator and DSP).
23	LED(DRCTCD)	O	LED output : DIRECT CD indication.	68	S - MTOF	I	Serial communication data input (Mechanism control).
24	P47	O	N.C. (OPEN)	69	S - FTOM	O	Serial communication data output (Mechanism control, character generator and DSP).
25	P46						
26	KSCAN5	O	Key scan output	70	xRESET OUT	O	Mother board reset output
27	KSCAN3/SEG M	O	Key scan output / Display segment output	71	xCS	O	CS output for character generator (PD0175A) (L : enable)
28	KSCAN3/SEG L						
29	KSCAN2/SEG K						
30	KSCAN1/SEG J						
31	KSCAN0/SEG I						
32	SEG H	O	Display segment output	72	P96	O	Not used (OPEN)
33	SEG G						
34	SEG F						
35	SEG E						
36	SEG D						
37	SEG C						
38	SEG B						
39	SEG A						
40	VDISP			I	- 27V	73	P97
				74	xCSDSP	O	CS output for DSP (PDQ001A) (L : enable)
				75	xEXTSEL	O	External input changeover switch output (H : Internal, L : External).
				76	AVCC	I	+5V
				77	ECHO	I	Control voltage input:ECHO control (0 - 5V)
				78	ONTA	I	Control voltage input:BALANCE control(0 -5V)
				79	P02	I	Not used (+5V pull up)
				80	P03		

Note ; H: High LEVEL, L: Low LEVEL, Z : High IMP.

8. FOR CLD-V740/KC AND CLD-1720K/SD

NOTES:

- Parts marked by "NSP" are generally unavailable because they are not in our Master Spare Parts List.
 - The Δ mark found on some component parts indicates the importance of the safety factor of the part. Therefore, when replacing, be sure to use parts of identical designation.
 - Parts marked by "☉" are not always kept in stock. Their delivery time may be longer than usual or they may be unavailable.
 - When ordering resistors, first convert resistance values into code form as shown in the following examples.
- Ex.1 When there are 2 effective digits (any digit apart from 0), such as 560 ohm and 47k ohm (tolerance is shown by J=5%, and K=10%).
- 560 Ω \rightarrow 56 \times 10¹ \rightarrow 561 RD1/8PM **561J**
 47k Ω \rightarrow 47 \times 10³ \rightarrow 473 RD1/4PS **473J**
 0.5 Ω \rightarrow 0R5 RN2H **0R5K**
 1 Ω \rightarrow 010 RS1P **010K**
- Ex.2 When there are 3 effective digits (such as in high precision metal film resistors).
- 5.62k Ω \rightarrow 562 \times 10¹ \rightarrow 5621 RN1/4PC **5621F**

CONTRAST OF MISCELLANEOUS PARTS

CLD-V740/KC, CLD-1720K/SD and CLD-V740/KU have the same construction except for the following :

Mark	Symbol & Description	Part No.			Remarks
		CLD-V740/KU	CLD-V740/KC	CLD-1720K/SD	
☉	PWSB assembly	VWM1404	Refer to 2.(4).
☉	SYPS assembly	VWR1160	VWR1160	VWR1187	
☉	VSBA assembly	VWR1188	
Δ	AC power cord	PDG1015	PDG1015	PDG1013	
Δ	Power transformer (AC120V)	VTT1119	VTT1119	
Δ	Power transformer (AC110V/120-127V/220V/240V)	VTT1118	
Δ	Strain relief	CM-22C	CM-22C	CM-22B	
Δ	Fuse (FU3:1A)	VEK1014	VEK1014	REK-100	Refer to 2.(4).
Δ	Fuse (FU1, FU2:3A)	VEK1021	VEK1021	
Δ	Fuse (FU1, FU2:3.15A)	REK-105	
NSP	Insulation sheet	VEC1406	
NSP	Rear panel	VNA1337	VNA1338	VNA1336	
	UPC code label	VRW1343	Refer to 2.(8).
	Tray panel assembly	VXA1970	VXA1970	VXA1969	
	Packing case	VHG1279	VHG1280	VHG1278	
	Operating instructions (French)	VRC1021	
	Operating instructions (Chinese)	VRC1020	
	Operating instructions (Spanish)	VRK1006	
NSP	Warranty card	ARY1044	ARY1039	ARW1020	

- PWSB ASSEMBLY
- SYPS ASSEMBLY
- VSBA ASSEMBLY

● PCB PARTS LIST

Mark	No.	Description	Part No.
SYPS ASSEMBLY			
SEMICONDUCTORS			
Δ		IC201, IC202, IC204	ICP-N15
Δ		IC203	ICP-N20
Δ		IC2	NJM4558D
Δ		IC1	NJM78M05FA
		Q5, Q22, Q23	2SA933S
Δ		Q1, Q2, Q25, Q27	2SB1185
		Q4, Q21, Q24	2SC1740S
Δ		Q3, Q26, Q28	2SD1762
Δ		D23, D26	10ELS2
Δ		D3, D33	11ES2
Δ		D24, D25	1SR35-100AVL
Δ		D21, D22	1SS254
Δ		D2	ERA83-006
		D7	MTZJ11B
Δ		D1	S2VB20

Mark	No.	Description	Part No.
COIL			
Δ		L1	L1043
CAPACITORS			
		C10, C29	CEAS101M50
		C13	CEAS102M16
		C25, C26	CEAS2R2M50
		C3-C6	CEAS470M10
		C27, C28	CFTYA223J50
Δ		C14	CGCYX473M25
		C23, C24	CGCYX473M25
		C11, C12	CKPUYF103Z25
Δ		C7-C9	CKPUYF223Z25
		C21, C22	QOMA272J50
Δ		C52	RCG-009
Δ		C2	VCH1053
Δ		C1	VCH1054
RESISTORS			
Δ		R27-R30	DCN1003
Δ		R23-R26	RD1/2VM221J
		Other resistors	RD1/6PM□□□□

CLD - V740
CLD - 1720K

Mark No.	Description	Part No.
OTHERS		
	CN31 KR CONNECTOR	B2B-PH-K
	6P CABLE HOLDER	51048-0600
	12P CABLE HOLDER	51048-1200
△	PCB BINDER	VEF1040
	POWER SUPPLY TERMINAL	VKC-019
△	FUSE HOLDER	VKR1001

Mark No.	Description	Part No.
VSBA ASSEMBLY		
SWITCH		
	VOLTAGE SELECTOR	VSB1007

9. CONNECTIONS

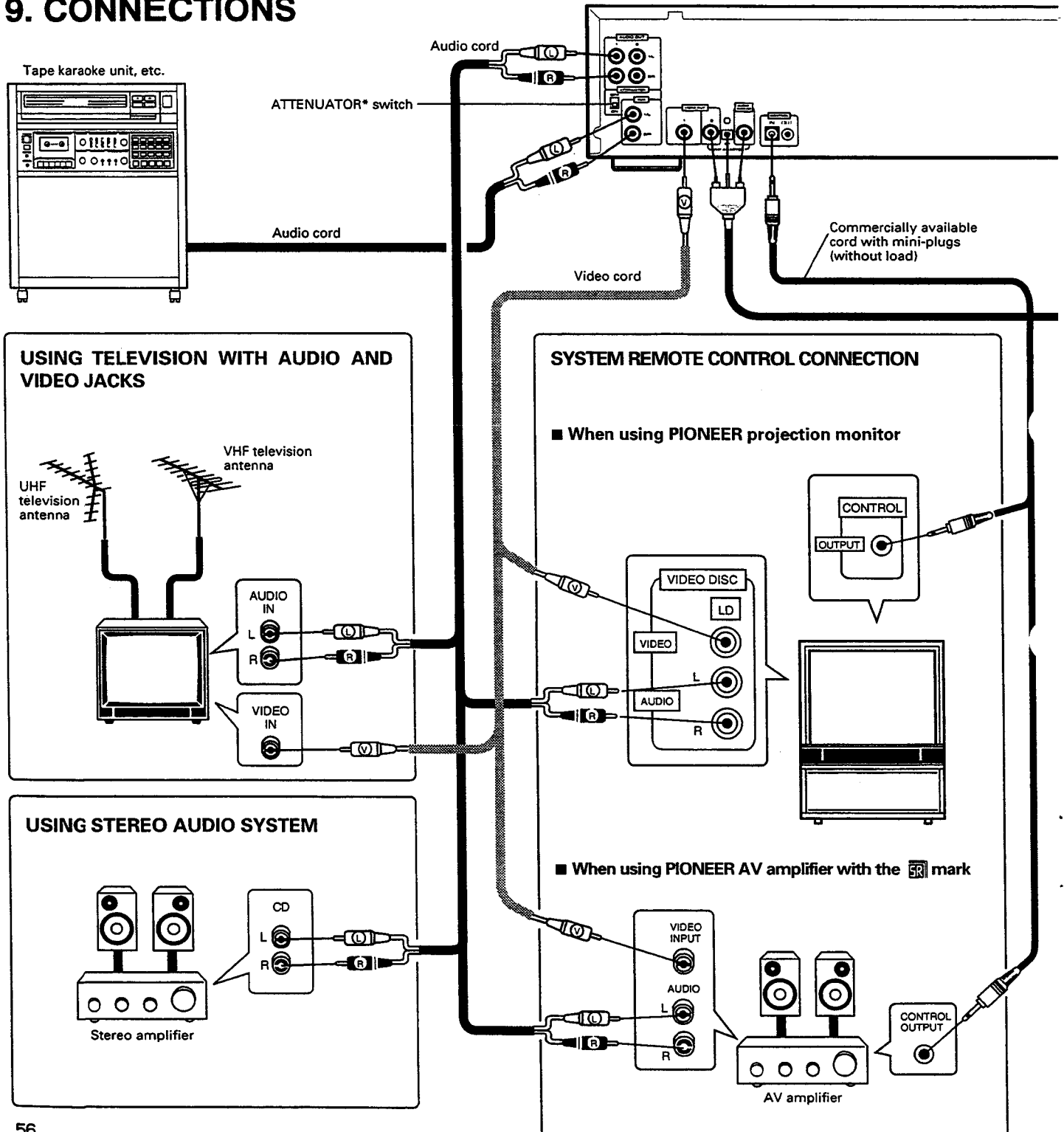

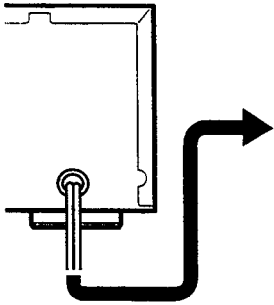

Plug the power cords into AC outlet.
 Plug the AC power cords of the player, stereo amplifier and TV set into an AC outlet. When the power cord of this unit is connected to an AC outlet, power is supplied to the unit's internal memory (such as the last memory) even when the POWER switch is off (STANDBY). Therefore, be sure to connect the power cord directly to a wall outlet. If the power cord is connected to an outlet such as a switched outlet on an amplifier, the various memory contents will be erased whenever the amplifier's power switch is turned off.

USING TELEVISION WITH AUDIO AND VIDEO JACKS

Monitor television connections

Connect the VIDEO OUT jack of the player to the video input jack of the monitor television.

- The television speakers can be used by connecting the television audio input jacks and the player AUDIO OUT jacks. However, connection to a stereo amplifier is recommended to obtain superior audio playback quality for Compact Discs and LaserDiscs. Do not change the television antenna and VCR connections.

• **ATTENUATOR switch (*)**

When the television speakers are used, the sound may be distorted. In this case, set ATTENUATOR to ON to reduce the distortion.

Stereo amplifier connections

Connect the AUDIO OUT jacks to the stereo amplifier AUX, CD, LD, VDP or other jacks.

- Do not connect these jacks to your amplifier PHONO input jacks.

Power cord connections

Connect the power cord to an AC wall outlet after connecting all components.

RF modulator JA-RF3L (Optional RF modulator is sold in the U.S. and Canada only.)

USING TELEVISION WITHOUT AUDIO AND VIDEO JACKS

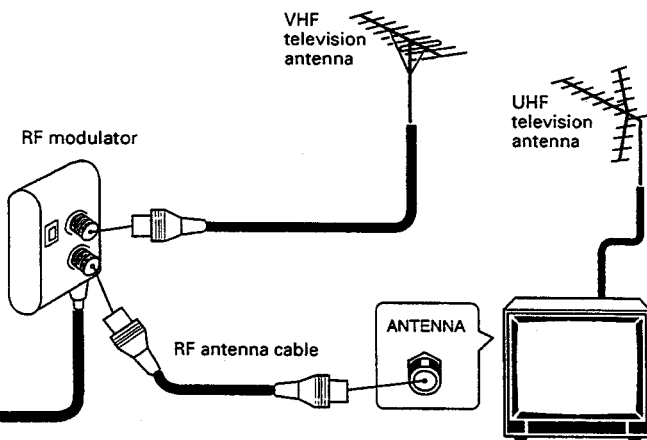

1. Detach the antenna cable from the antenna terminal of your TV set, and connect the cable to the IN terminal of the RF modulator.
2. Connect the OUT terminal of the RF modulator to the antenna terminal of your TV set.
3. Connect the socket (3-pin) of the RF modulator to the VHF ADAPTER jacks.

NOTE:
 Push the plug in firmly. If the plug is not properly inserted, it may result in snow on the screen or noise.

When the sound from a LaserDisc or Compact Disc is output from a television speaker it becomes monaural sound. (This is the same as stereo television).

NOTES:

- Stripe patterns may appear when a LaserDisc is played on a television. Move the antenna cable away from the power cord to avoid this.
- Be sure to turn off the power of this player when you watch a TV broadcast.
- When the television speakers are used, the sound may be distorted. In this case, set ATTENUATOR to ON to reduce the distortion.
- With some televisions, when CD is played in Direct CD mode, no sound will be heard. Therefore, when using television speakers, turn off DIRECT CD.

10. PANEL FACILITIES

- Most of the buttons on the front panel are used for Karaoke play.

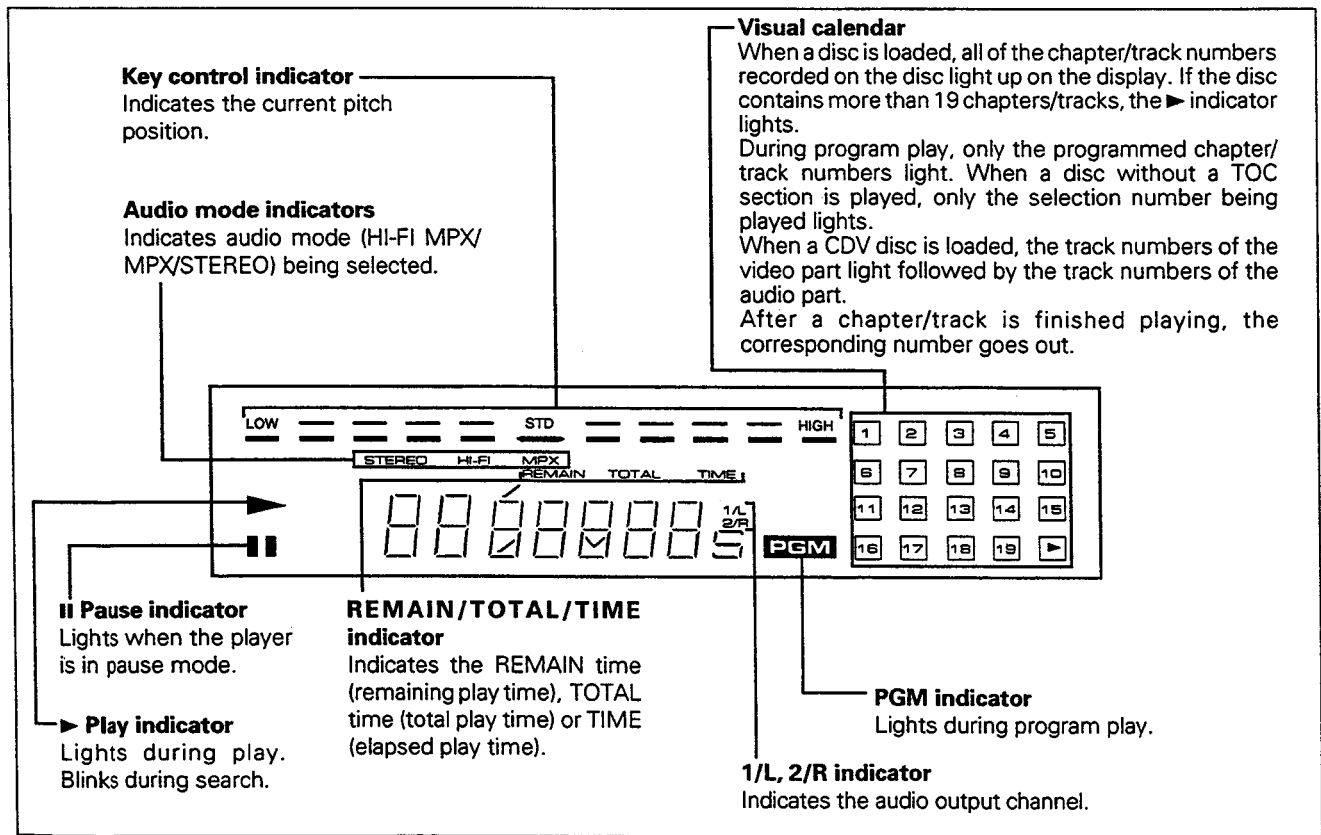
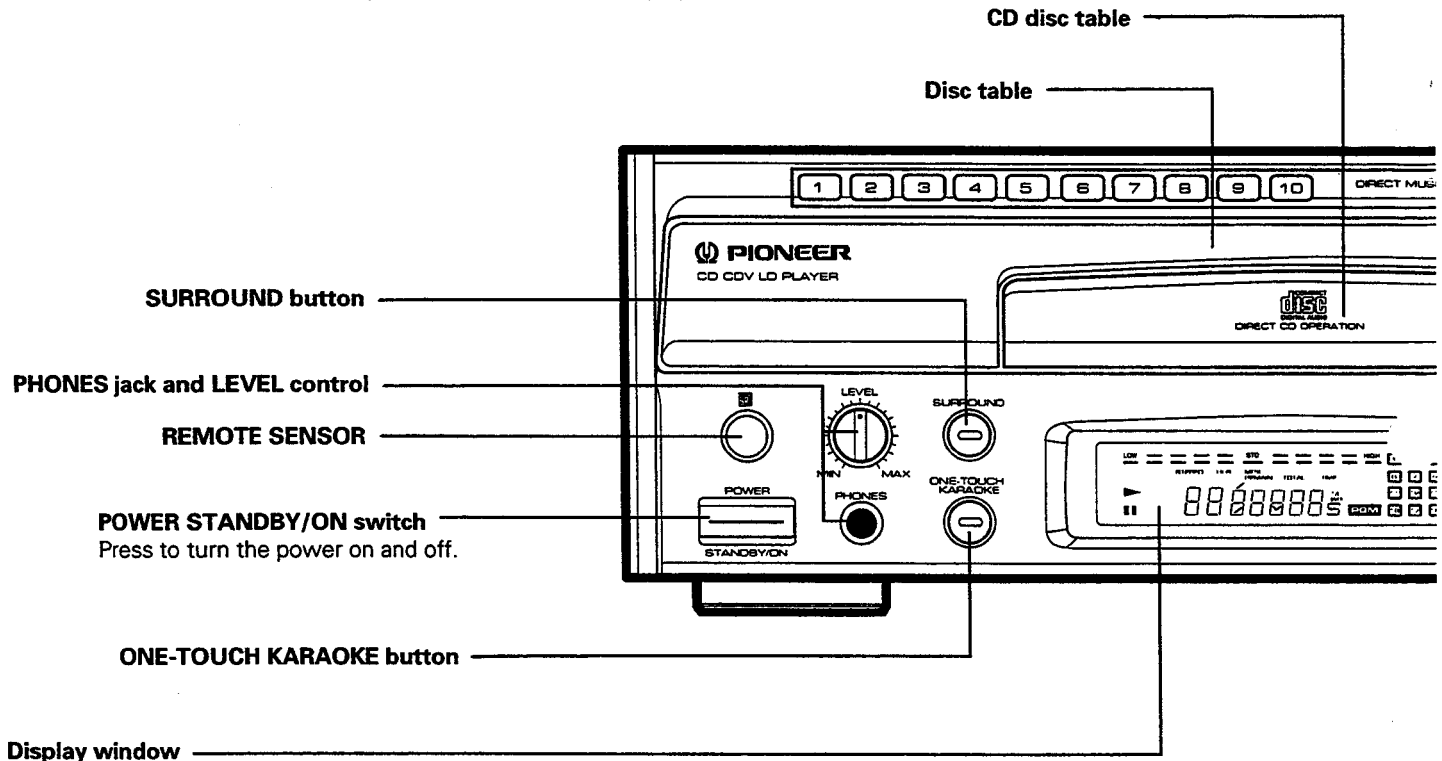

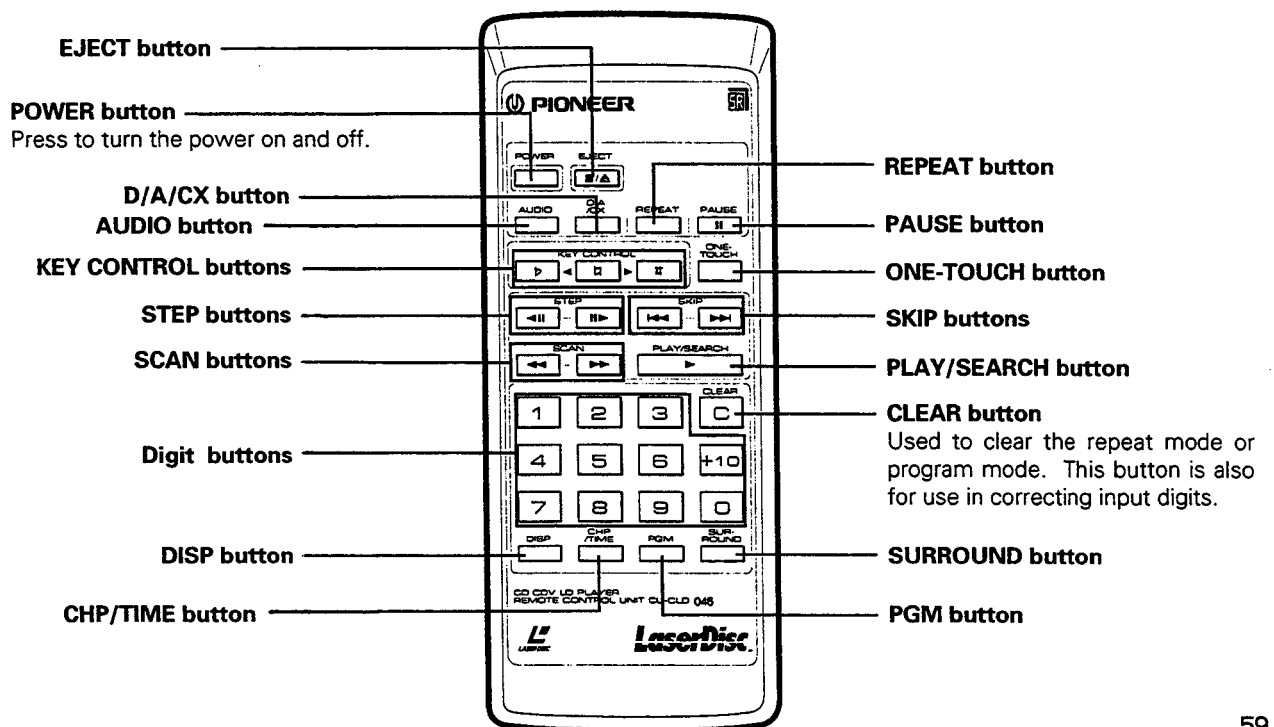
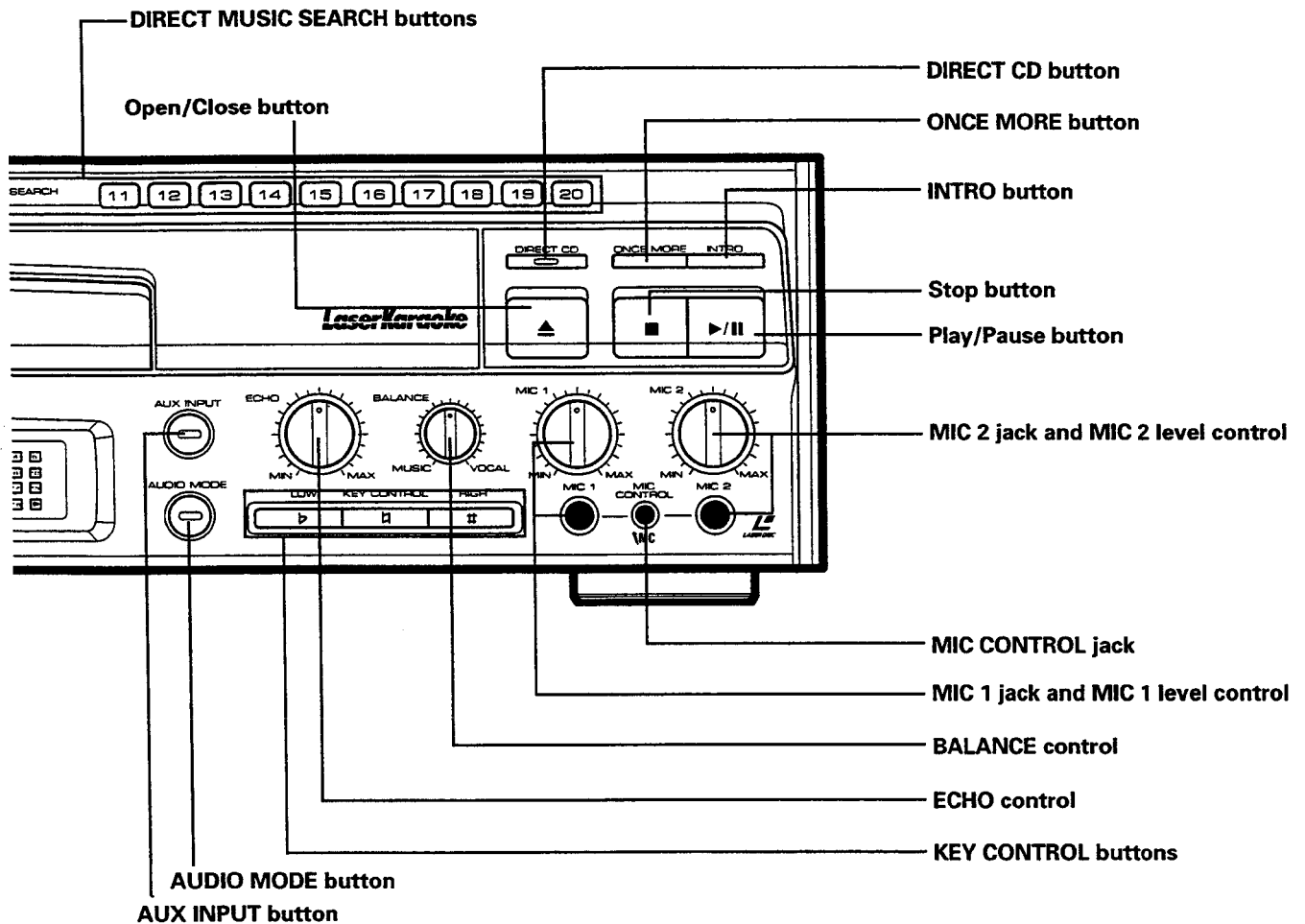

11. SPECIFICATIONS

1. General

System	LaserVision Disc system and Compact Disc digital audio system
Laser	Semiconductor laser wavelength 780 nm
Power requirements	
CLD-V740	AC 120 V, 60 Hz
CLD-1720K	AC 110/120~127/220/240 V (Switchable), 50/60 Hz
Power consumption	
CLD-V740	42 W
CLD-1720K	42 W
Weight	7.5 kg (16 lbs 7 oz)
Dimensions	420 (W) x 392 (D) x 122 (H) mm
	16-9/16 (W) x 15-7/16 (D) x 4-13/16 (H) in
Operating temperature	+5°C ~ +35°C (41°F - 95°F)
Operating humidity	5% ~ 85%
	(There should be no condensation of moisture.)

2. Disc

LaserVision Discs

*Maximum playing times	
12-inch standard play disc	1 hour/both sides
12-inch extended play disc	2 hours/both sides
8-inch standard play disc	28 min/both sides
	14 min/one side
8-inch extended play disc	40 min/both sides
	20 min/one side
Spindle motor speed	
Standard play disc	1,800 rpm
Extended play disc	1,800 rpm (inner circumference)
	to 600 rpm (outer circumference)
	(For a 12-inch disc)

Compact Discs

DISC	Diameter: 5-inch, 3-inch, Thickness: 1.2 mm
Rotation direction (pickup side)	Counterclockwise
Linear speed	1.2 ~ 1.4m/sec
*Maximum playing time	74 min. 5-inch discs
	20 min. 3-inch discs
	(For stereo playback)

Compact Discs with Video

Disc	Diameter: 5-inch, Thickness: 1.2 mm
Rotation direction (pickup side)	Counterclockwise
Linear speed	Audio portion: 1.2 ~ 1.4m/sec
	Video portion: 11 ~ 12m/sec
*Maximum playing time	Video portion: 5 min. (CLV)
	Audio portion: 20 min. (Digital)

* Actual playback time differs for each disc.

3. Video characteristics (two pairs)

Format	NTSC specifications
Video output	
Level	1 Vp-p nominal, sync. negative, terminated
Impedance	75Ω unbalanced
Jack	RCA jack

4. Audio characteristics (two pairs)

Output level	
During analog audio output	200 mVrms
	(1 kHz, 40%)
During digital audio output	200 mVrms
	(1 kHz, -20 dB)
Jacks	Both RCA jacks
Number of channels	2

5. Other Terminals

Microphone input	2
MIC control input	miniature jack
Headphones output	1
Control input/output	Both miniature jacks
VHF adapter output (Video/Audio)	Both RCA jacks
	with DC jack

6. Accessories

Remote control unit (CU-CLD046)	1
Size "AAA" (IEC R03) dry cell batteries	2
Video cord	1
Audio cord	1
Operating instructions	1
Warranty card	1

7. Functions

Remote control unit operations (CU-CLD046)

	Function	Standard play Disc (CAV)	Extended play Disc (CLV)	Compact Disc with Video	Compact Disc
Basic Functions	Pause Stop Eject	YES YES YES	YES YES YES	YES YES YES	YES YES YES
Search	Fast forward (forward and reverse) Chapter/Track skip Direct chapter/Track number search Frame number search Time number search Absolute time search	YES YES YES YES NO NO	YES YES YES NO YES NO	YES YES YES NO YES NO	YES YES YES NO YES YES
Program	Chapter/Track program play Program correction	YES YES	YES YES	YES YES	YES YES
Repeat	Chapter/Track repeat One-side repeat Program repeat	YES YES YES	YES YES YES	YES YES YES	YES YES YES
Trick play	Still/Step	YES	NO	NO	NO
Time display	Elapsed time display Absolute time display Remaining track time display Remaining total time display Total number of selections, total time display	NO YES*1 NO YES*1 YES*1	YES NO NO YES*1 YES*1	YES NO YES YES YES	YES YES YES YES YES
Others	CX system ON/OFF AUTO DIGITAL/ANALOG switch Audio channel selection (Stereo, 1/L, 2/R) Intro Scan	YES*2 YES*3 YES*4 YES	YES*2 YES*3 YES*4 YES	NO NO YES*4 YES	NO NO YES*4 YES

*1 Only discs with TOC

*2 Valid for analog audio playing a disc with the  mark.

*3 Can only be used with discs with digital audio tracks.

*4 Only NORMAL mode

NOTE:

The specifications and design of this product are subject to change without notice, due to improvements.

SERVICE INFORMATION

(1 / 1)



No. : SI-V48182

Date: Apr.15,1994

MODEL NO.	*	SER. NO.	*	MODEL NO.	*	SER. NO.
CLD-V740/KC		3403401-				
CLD-V740/KU	A	NH3606501-				
CLD-1720K-A/SDX1IN		NG2605001-				
CLD-1720K/SD	▼	NG2646501-				

#	DETAIL OF CHANGE(S)	#	REASON FOR CHANGES
1	Addition of a resistor and a capacitor in MAIN Assy	1	To prevent mis-search in the adjustment state

MAIN Assy

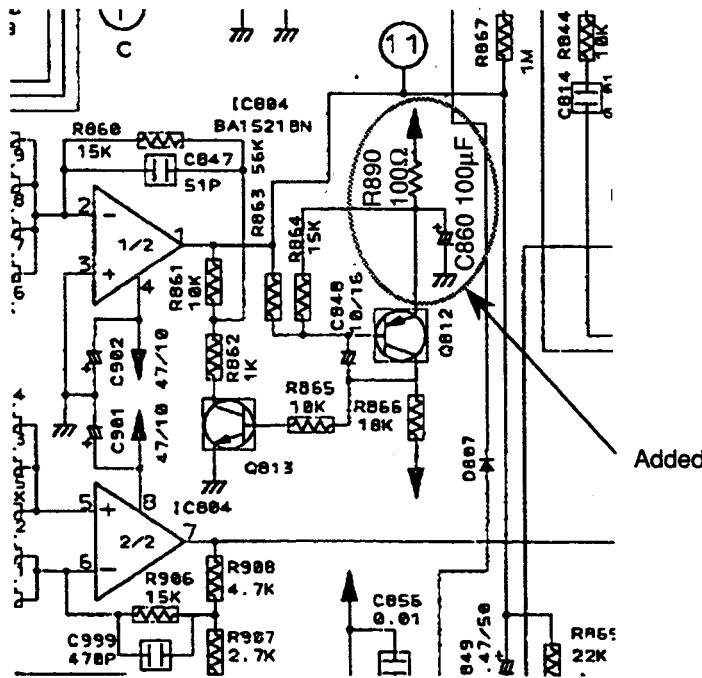

SERVICE MANUAL

MODEL: CLD-V740
CLD-1720K
S/M NO.: ARP2803
PAGE : 27

MODEL:
S/M NO.:
PAGE:

MODEL:
S/M NO.:
PAGE:

MODEL:
S/M NO.:
PAGE:

Ref.	CURRENT PARTS		CO	NEW PARTS	
#	#	SYMBOL/DESCRIPTION	DE	PART NUMBER	SYMBOL/DESCRIPTION
A	1		-	CEAS101M10	C860(100μF)
A	1		-	RD1/6PM101J	R890(100Ω)

PIONEER ELECTRONIC CORPORATION

(SPC48-399, TB-16547 SPC-HK 104)

Y. Imamizu

Y. IMAMIZU, MANAGER
HE Engineering Section
Service Dep.

388^u

PIONEER
The Art of Entertainment

Service Manual

SERVICE GUIDE

ORDER NO.
ARP2528

CD CDV LD PLAYER

CLD-S201 CLD-S250

CONTENTS

1. DISASSEMBLY	2
2. DESCRIPTION OF MECHANISM	7
2.1 OUTLINE OF MECHANISM	7
2.2 DESCRIPTION OF OPERATION	11
3. DESCRIPTION OF THE SYSTEM CONTROL	20
3.1 MICRO COMPUTER INTERFACE	21
3.2 MICRO COMPUTER COMMUNICATION SEQUENCE	21
3.3 OUTLINE OF THE MECHANISM CONTROL SYSTEM	22
3.4 FLOW CHARTS OF VARIOUS OPERATIONS	30
3.5 OUTLINE OF THE MODE CONTROL SYSTEM	37

PIONEER ELECTRONIC CORPORATION 4-1, Meguro 1-Chome, Meguro-ku, Tokyo 153, Japan
PIONEER ELECTRONICS SERVICE INC. P.O. Box 1760, Long Beach, California 90801 U.S.A.
PIONEER ELECTRONICS OF CANADA, INC. 300 Allstate Parkway Markham, Ontario L3R 0P2 Canada
PIONEER ELECTRONIC [EUROPE] N.V. Haven 1087 Keetberglaan 1, 9120 Melsele, Belgium
PIONEER ELECTRONICS AUSTRALIA PTY. LTD. 178-184 Boundary Road, Braeside, Victoria 3195, Australia TEL: [03] 580-9911
 © **PIONEER ELECTRONIC CORPORATION 1992**

AO MAY 1992 Printed in Japan

388^u

1. DISASSEMBLY

• Removing the Tray Unit

1. Set DIRECT CD to OFF (indicator lamp goes OFF).
2. Remove the two fixing screws (Z) (Fig. 1-1).
3. Press the OPEN/CLOSE button to set the tray unit to its OPEN position.
- * When manually setting the tray unit to its OPEN position, refer to Notes 1 and 2.
4. Pull out the tray unit while pressing the hook (A) (Fig. 1-1), located on the rear right side of the tray unit, to the left.

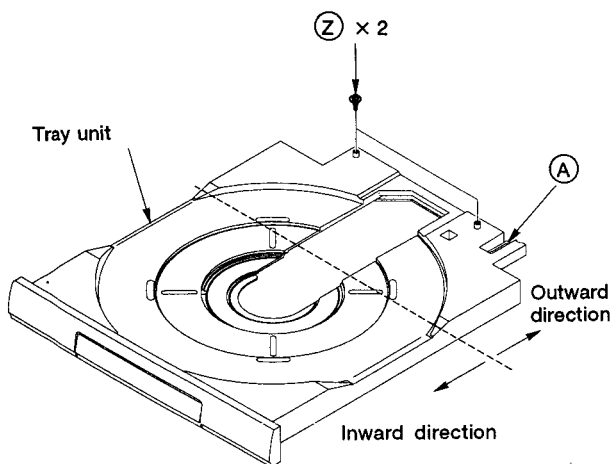

Fig. 1-1

Note 1. Manually setting the tray unit to its OPEN position

1. Remove the clamber unit (B) (Fig. 1-2) by loosening its four screws.

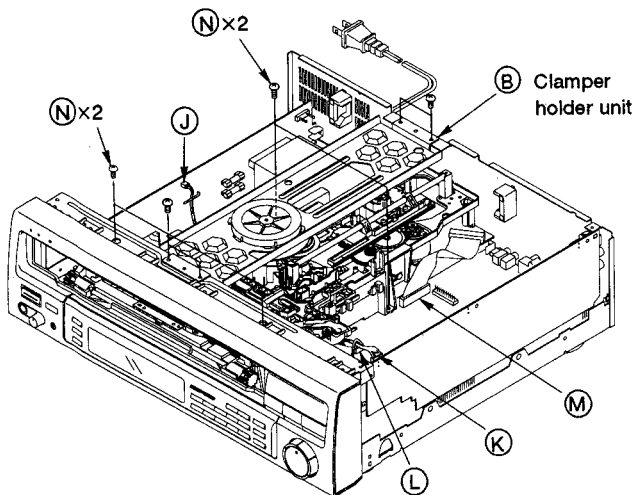

Fig. 1-2

2. Make sure that the position of the lens in the pickup assembly is such that the lens stops outside the position indicated by the dotted line in Fig. 1-1. When the lens stops inside the dotted line, slowly press the (Q) portion of the rack assembly (Fig. 1-3) to move the lens in the pickup assembly until the lens is outside the position indicated by the dotted line in Fig. 1-1.

Note that by not going through this process, opening the CD tray and removing the tray ASS'Y would be more time-consuming.

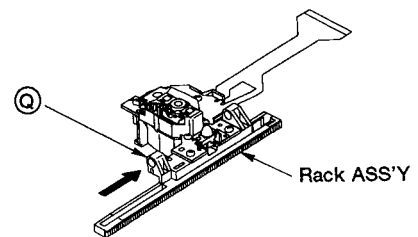

Fig. 1-3

3. Insert your hand through the right side of the tray unit and turn the gear pulley (C) (Fig. 1-4) in a clockwise direction until the servo-mechanism unit (D) (Fig. 1-5) lowers. Keep turning the pulley until the tray unit starts to move towards the front.

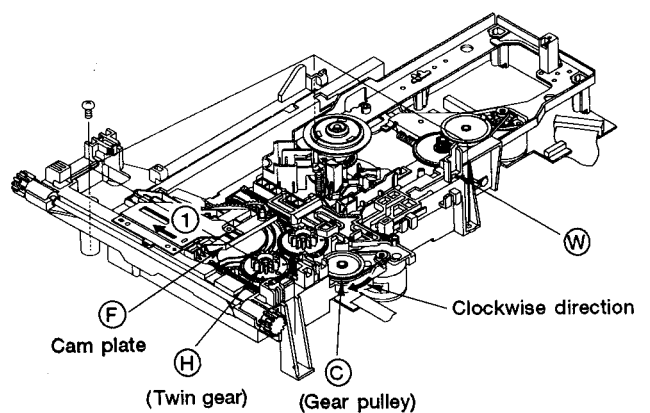

Fig. 1-4

4. Slowly pull out the tray unit to the OPEN position.

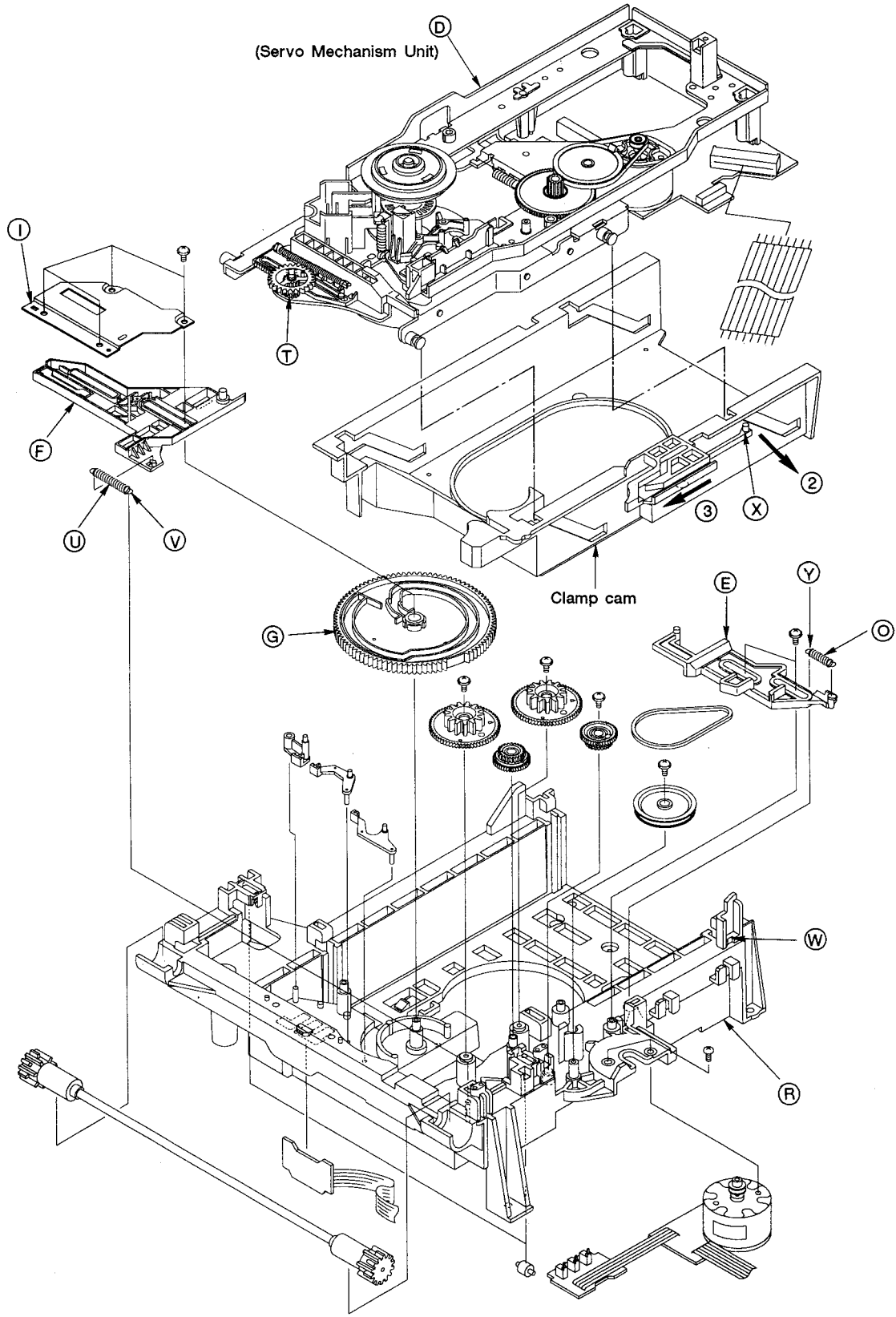

Fig. 1-5

Note 2. Setting the tray unit to its OPEN position when the CD tray is completely or partially OPEN

1. Remove the clamber unit ② (Fig. 1-2) by loosening its four screws.
2. Slowly push in the CD tray to the CLOSE position.
3. Slowly press the ③ portion of the rack assembly (Fig. 1-3) to move the lens in the pickup assembly until the lens is outside the position indicated by the dotted line in Fig. 1-1.
4. Insert your hand through the right side of the tray unit and turn the gear pulley ④ (Fig. 1-4) in a counterclockwise direction until the servo-mechanism unit ⑤ (Fig. 1-5) starts to move upward. Keep turning the pulley until the clamp position is reached (the LD tray and CD tray become one unit).
5. When the clamp position has been reached, turn the gear pulley ④ (Fig. 1-4) in a clockwise direction until the servo-mechanism unit ⑤ lowers. Keep turning the pulley until the tray unit starts to move towards the front.
6. Slowly pull out the tray unit to the OPEN position.

● **Attaching the Tray Unit**

1. Make sure that the CD plate ⑥ is positioned to the left (LD Tray mode) as in Fig. 1-6. When the CD plate ⑥ is positioned to the right (CD Tray mode) as in Fig. 1-6, perform steps 1) to 2).

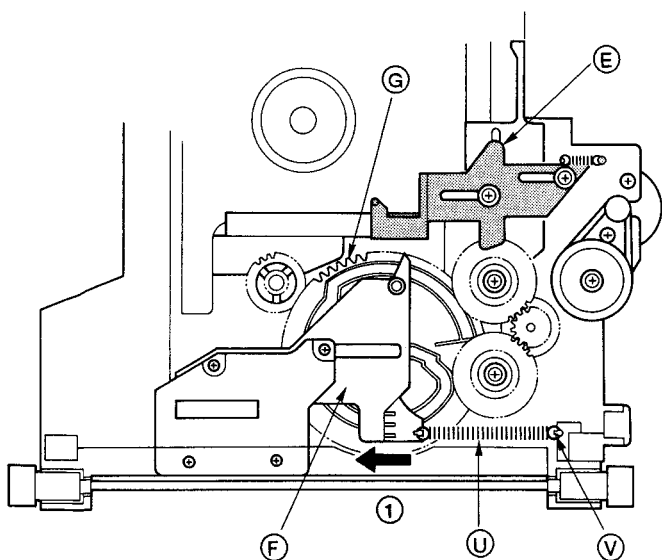

Fig. 1-6

- 1) Turn the power ON. While DIRECT CD is OFF, push cam plate ⑥ (Fig. 1-6) towards the direction of the arrow ①.
- 2) Wait until the cam gear ⑧ (Fig. 1-6) turns, the servo-mechanism unit ⑤ (Fig. 1-5) goes upward, and the pickup assembly stops moving.
2. Press the OPEN/CLOSE button to open the tray unit, or pull out the power cord from the AC outlet and turn the twin gear ④ (Fig. 1-4) in a counterclockwise direction until the cam gear ⑧ (Fig. 1-6) can no longer turn.
3. Keeping the tray unit parallel with the front panel, slowly insert the tray unit through the opening of the front panel.

Note that if you insert the tray unit in the front panel when the tray unit and the front panel are not parallel with each other, the tray unit might get stuck while being inserted.

● **Removing the Servo-Mechanism Unit**

1. Remove the clamber unit ② (Fig. 1-2) by loosening its four screws, and remove the tray unit.
2. Remove the four connectors ⑪ to ⑭ (Fig. 1-2).
3. Remove the four fixing screws ⑫ of the mechanism base and remove the whole servo-mechanism unit from its casing.
4. Remove the ⑬ side of the CDP spring ⑩ (Fig. 1-5) as well as the CD plate ⑥ by loosening the CD plate's two screws.
5. Remove the lead wire from the lead wire hook ⑬ (Fig. 1-7) for the spindle motor at the rear of the mechanism base ⑯.

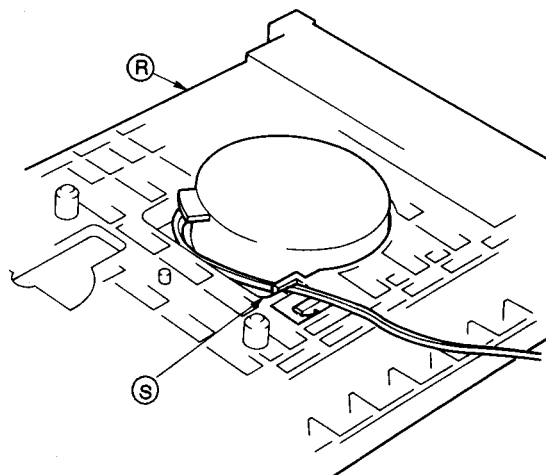

Fig. 1-7

6. While pushing the cam plate ⑥ (Fig. 1-4) towards the direction of the arrow ①, turn the twin gear ④ (Fig. 1-4) in a clockwise direction.
7. Stop turning the twin gear ④ (Fig. 1-4) when the servo-mechanism unit ① (Fig. 1-5) has gone upward and the Y-gear ① is engaged with the cam gear ③ by three to five teeth.
8. While bending the clamp cam hook ⑧ (Fig. 1-5) in the direction of the arrow ②, move the hook to its "built-in position" ⑦ (Fig. 1-4) towards the rear.
9. Lift the servo-mechanism unit ① straight up and remove the unit from the clamp cam (Fig. 1-5).

● Attaching the Servo-Mechanism Unit

1. Return the clamp cam and other parts to their original positions (when the servo-mechanism unit was removed).
2. While turning the Y-gear ① in a clockwise direction by three to five teeth (Fig. 1-8) in the same manner as when the Y-gear was removed, attach the servo-mechanism unit from above to the clamp cam (Fig. 1-5).
3. While bending the clamp cam hook ⑧ in the direction of the arrow ②, move the hook in the direction of the arrow ③ (Fig. 1-5).
4. While the servo-mechanism unit is raised, hook the lead wire from the spindle motor to hook ⑤ (Fig. 1-7) on the rear of the mechanism base ④.
5. Turn the twin gear ④ (Fig. 1-4) in a counterclockwise direction until the servo-mechanism unit lowers, the cam gear ③ (Fig. 1-5) stops turning, and the twin gear ④ (Fig. 1-4) runs idle.

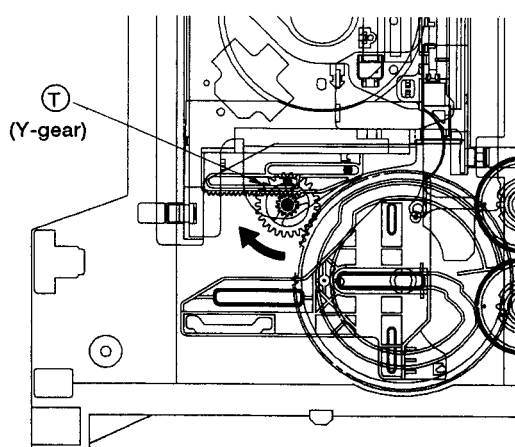

Fig. 1-8

● Attaching the Cam Gear and Cam Plate

1. Bring the clamp cam (Fig. 1-5) close towards you (while the servo-mechanism unit is being lowered).
2. Insert the cam gear ③ upon directing the rib horizontally as shown in Fig. 1-9.

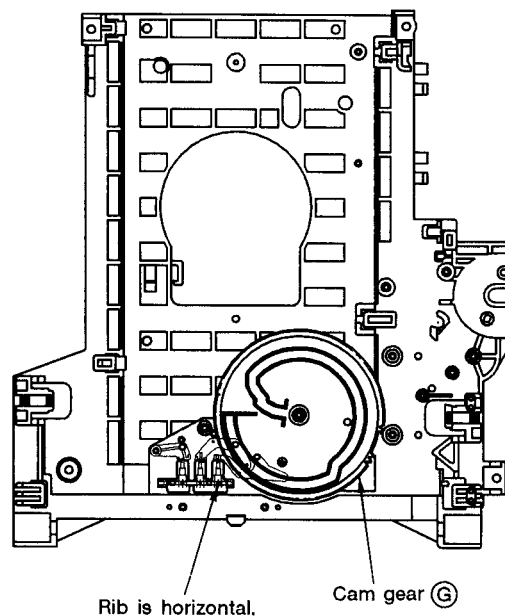

Fig. 1-9

3. Attach the CAS spring, ① (Fig. 1-6) to the cam plate ⑥, and hook the ② side of the CAS spring to the spring-latching part of the mechanism base.

- Slightly turn the cam gear ③ in a counterclockwise direction until the cam gear reaches the position shown in Fig. 1-10.

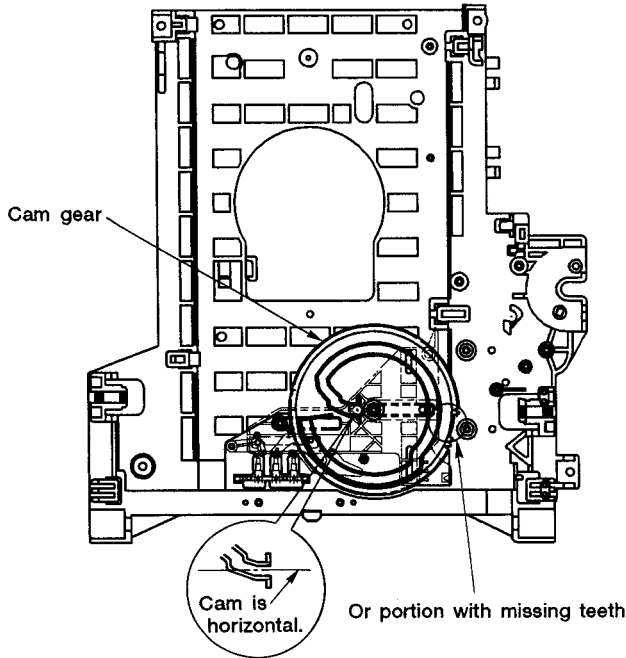

Fig. 1-10

- Attach the cam plate ⑥ on the cam gear ③ when the plate has moved to the rightmost position (Fig. 1-6).
- Fix the shaft holder ① using four screws (Fig. 1-5).

● **Matching the Position of the Gears**

- Attach the center gear ④, twin gears ⑤① and ⑤②, and Y-gear ① in the positions indicated in Fig. 1-11.

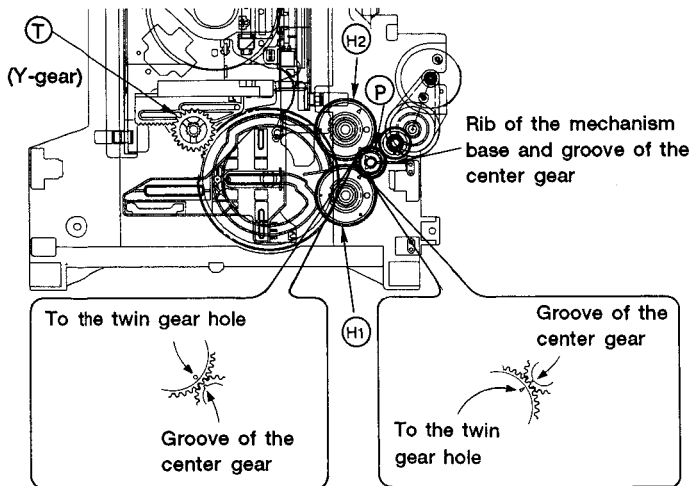

Fig. 1-11

● **Attaching the CD Plate**

- Upon attaching the CD spring ⑦ (Fig. 1-5) to the CD plate ⑧, hook the ⑨ side of the CD spring to the mechanism base hook.
- Attach the CD plate ⑧ (from the left side) into the position shown in Fig. 1-6.

2. DESCRIPTION OF MECHANISM

2.1 OUTLINE OF MECHANISM

The mechanism consists of the following four independent units:

- ① Loading mechanism unit (Fig. 2-2)
- ② Servo-mechanism unit (Fig. 2-3)
- ③ Tray unit (Fig. 2-4)
- ④ Clamper unit (Fig. 2-6)

The tray unit only moves in the horizontal direction (forward and backward) due to the ascending and descending movements of the servo-mechanism unit, while the clamper unit is fixed inside a casing. These are some of the distinct features of the mechanism. Moreover, a CD tray is added to the LD tray in the tray unit, a feature not found in previous models.

The major components of each unit are described below.

① Loading Mechanism Unit (Refer to Fig. 2-2)

The loading mechanism unit consists of the following: a DC motor (carriage motor) which is the drive source of the mechanical base, a clamp cam which guides the ascending and descending movements of the servo-mechanism unit, a tray unit, a cam gear which engages the movement of the loading mechanism unit with that of the tray unit, a cam plate, and gears for reducing speed during operation. A detection system for each operation mode of the mechanism is included in the loading mechanism unit through the switch circuit board assembly and is connected together with the power supply of the DC motor.

By attaching the servo-mechanism unit and tray unit to the loading mechanism unit, the operations of the mechanism are completed without using the casing and other supporting components (Fig. 2-2) (excluding the operations of the clamper unit and clamp).

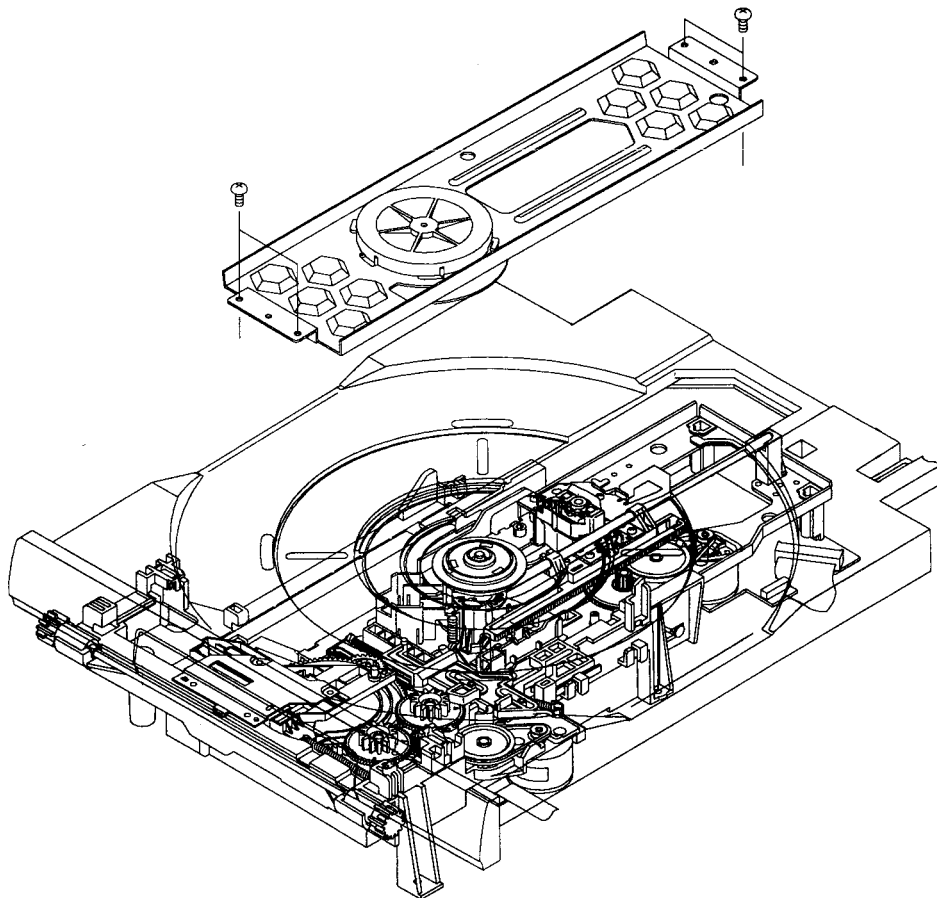

Fig. 2-1

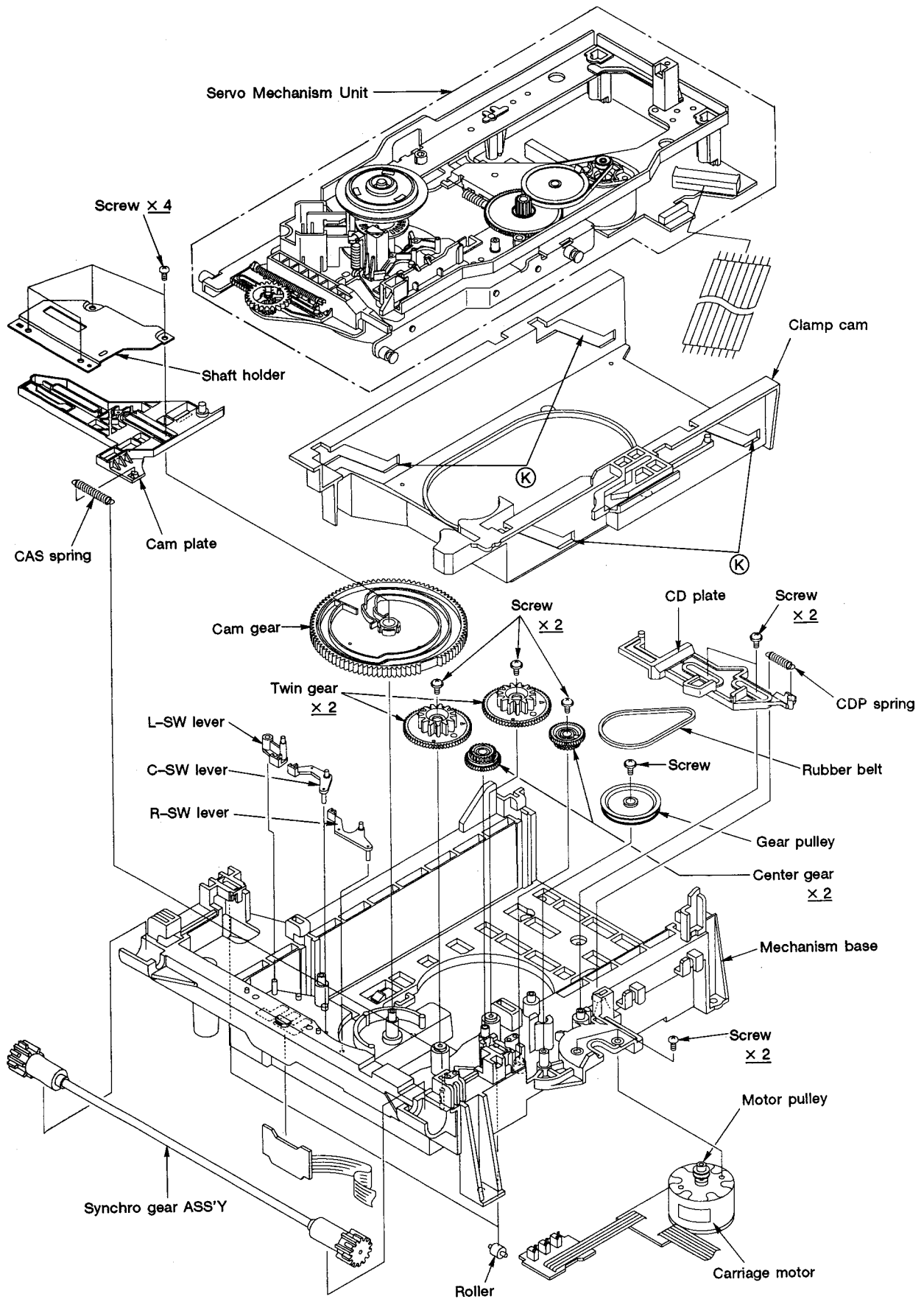

Fig. 2-2 Loading Mechanism unit

② Servo-Mechanism Unit (Refer to Fig. 2-3)

The servo-mechanism unit is mainly divided into two parts: one is related to the tilt base, while the other is related to the motor base.

The tilt base consists mainly of the following: a rack assembly which includes the pickup assembly, a carriage shaft for the guide of the rack assembly, a DC motor (shared with the loading mechanism unit) for driving the rack assembly, and various gears. Similar to the loading mechanism unit, a detection system for the pickup assembly is included through the switch circuit board

assembly and is connected to the exterior of the servo-mechanism unit, together with the signal lines from the DC motor power supply and pickup assembly, via the CAMB assembly.

The motor base consists of the following: a spindle motor assembly, a tilt cam which guides the tilt operation of the tilt base, and a Y-gear which engages the loading mechanism unit with the tilt cam.

The tilt base is set on top of the motor base. Both bases are fixed with screws in every direction (up/down, left/right, and front/rear).

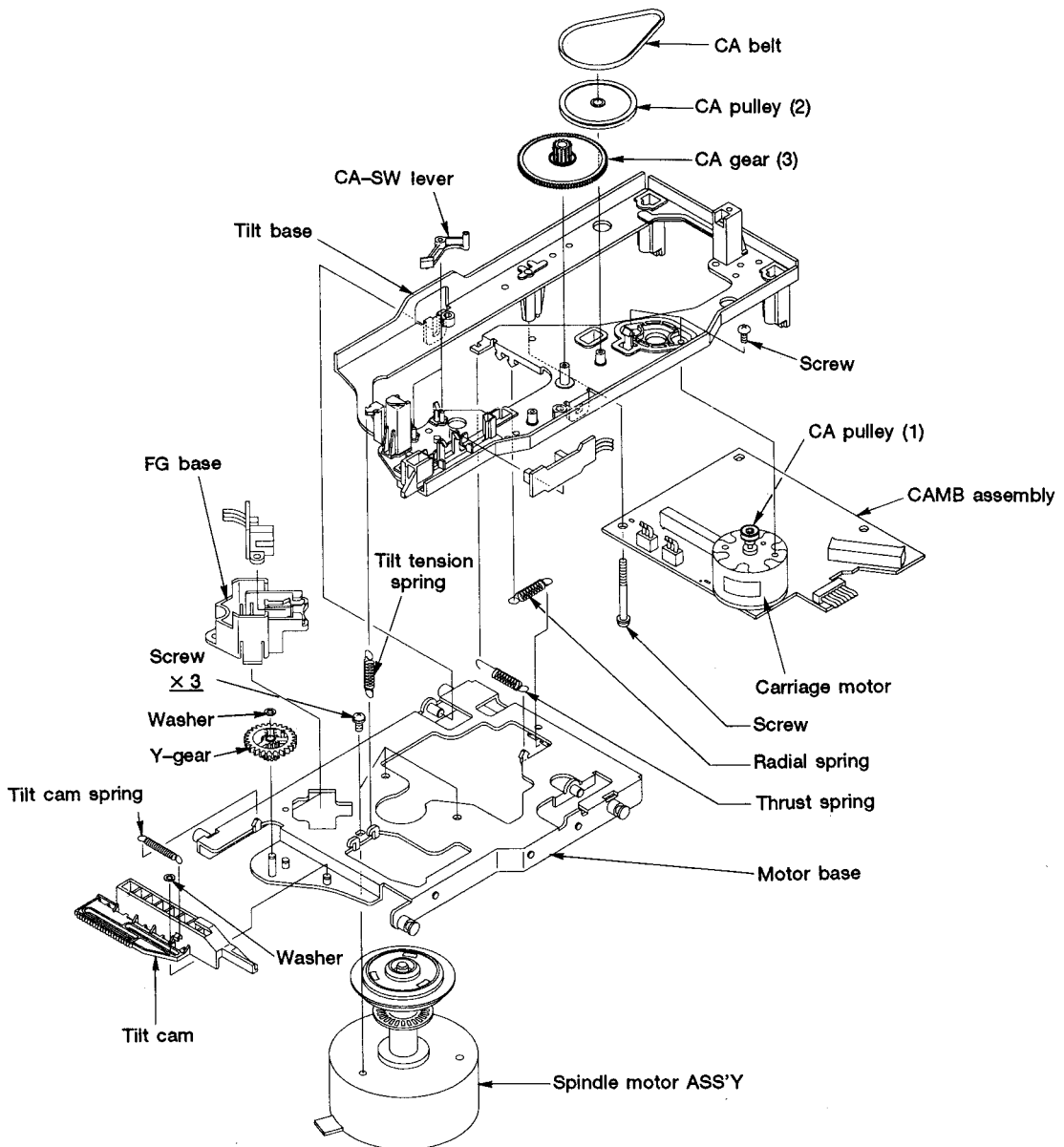

Fig. 2-3 Servo Mechanism unit

③ Tray Unit (Refer to Fig. 2-4 and Fig. 2-5)

Two guide plates (left and right) are attached on the bottom side of the LD tray. In between the guide plates is a lock plate used in CD/LD tray operation switching and a lock plate spring.

As a support system to the tray unit, two protruding portions ① (Fig. 2-5) are located on the front, left of the mechanism base, and a cam groove ② (Fig. 2-4) is located on the bottom side for the left/right movements

of the LD tray. Rollers ③ (Fig. 2-5) are located on the left and right of the mechanism base, and a synchro gear assembly ④ exists for the up/down movements of the LD tray. The synchro gear assembly ensures left/right synchronization. As for the CD tray, a protruding rib ⑤ (Fig. 2-4) is located on the bottom side of the LD tray for the left/right movements, while guide plates are located on the left and right of the rib for the up/down movements.

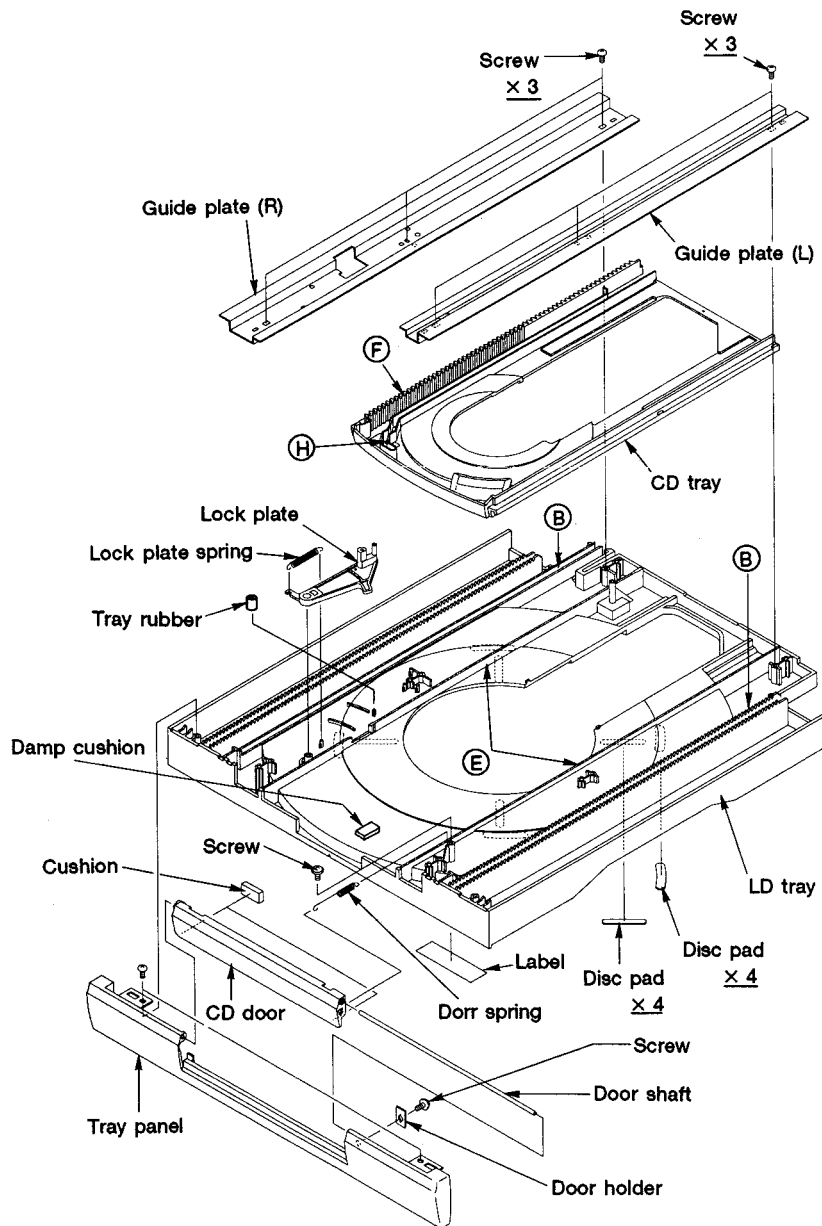

Fig. 2-4 Tray unit (Bottom view)

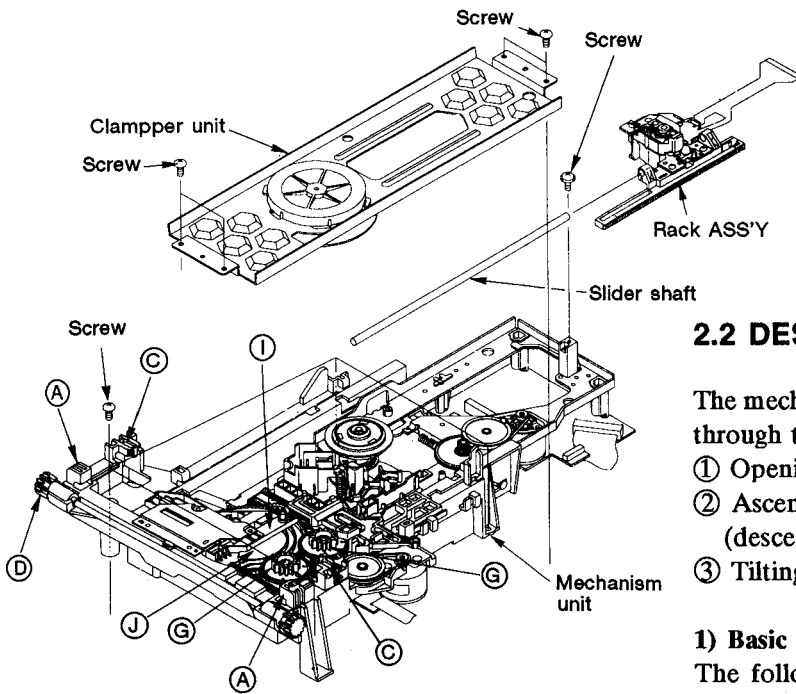

Fig. 2-5 Mechanical unit

④ Clammer Unit (Refer to Fig. 2-6)

A clammer head and three clammer springs are temporarily fixed onto the clammer. The clammer is fixed as a unit by the clammer holder via the clammer arm. The clamp is held in place by later attaching a stabilizer.

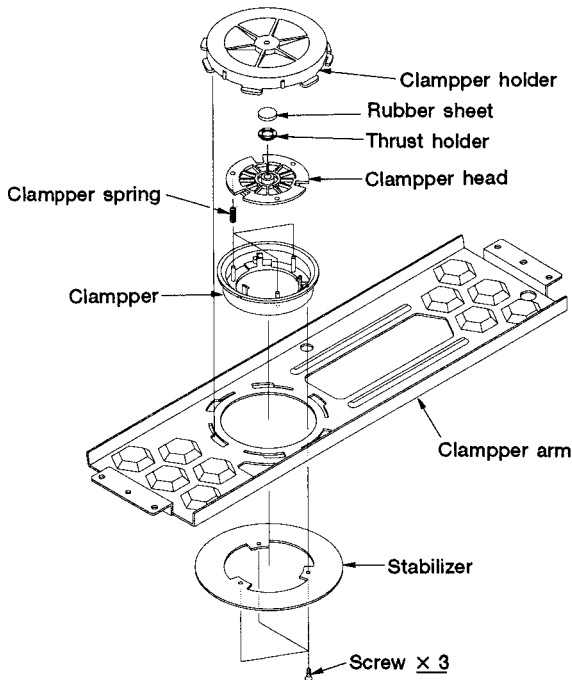

Fig. 2-6 Clammer unit

2.2 DESCRIPTION OF OPERATION

The mechanism performs the following operation modes through the loading motor:

- ① Opening/closing of tray unit
- ② Ascending/descending of servo-mechanism unit (descending: disc clamp)
- ③ Tilting of servo-mechanism unit

1) Basic operations

The following describes operations from ejecting the tray, loading the disc, to playback.

① Loading the Tray

While the rack gear ⑥ (Fig. 2-4) and twin gear ⑦ (Fig. 2-5) the bottom side of the CD tray are engaged, the cam gear ⑩ is engaged with the twin gear ⑦ by moving the cam plate ① through the cam ⑧ (Fig.2-4) on the bottom side of the CD tray. (The rack gear on the bottom side of the CD tray is separated from the twin gear.)

② Ascending of the Servo-Mechanism Unit

The clamp cam is moved towards the rear by engaging the cam and boss on the back side of the cam gear to the clamp cam (Fig. 2-7). The servo-mechanism assembly ascends through the cam ⑫ (Fig. 2-2) on the clamp cam.

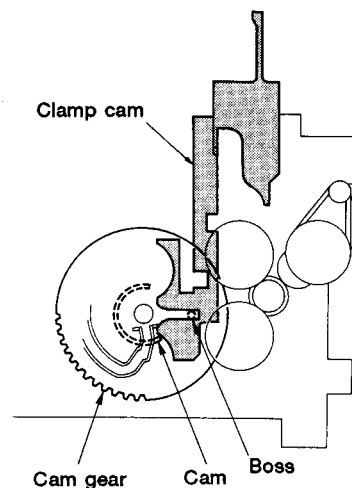

Fig. 2-7

③ Clamping the Disc

While the servo-mechanism unit is ascending, the disc on the tray is lifted and the clamber waiting on top is pushed up. Clamping force is generated (Fig. 2-6) from the force of the clamp spring between the clamber and clamber head.

④ Tilting the Servo-Mechanism Unit

The Y-gear on the motor base, from ascending of the servo-mechanism unit to clamping, and cam gear are engaged to drive the tilt cam (Fig. 2-8). Since support points from the tilt base are provided on the slanted side ① (Fig. 2-8) of the tilt cam, tilting is performed by the left/right movements of the tilt cam.

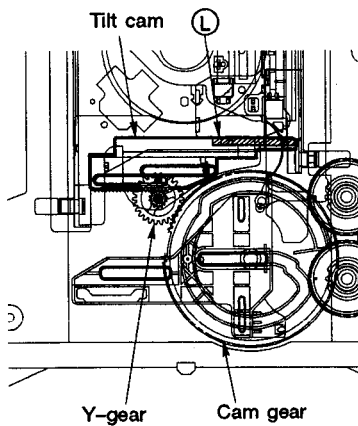

Fig. 2-8

2) LD/CD Tray Identification → Eject Operations

① Selecting the LD Tray (Refer to Fig. 2-9)

To unclamp (when the servo-mechanism unit is lowered), the clamp cam moves in reverse (towards the front panel). Since the CD plate is forced to the left by the CD spring (Fig. 2-9 ①), the plate is inserted in the (LD) direction of the cam on the upper right side of the clamp cam. The lock plate on the tray is turned to the left by the lock plate spring (Fig. 2-9 ②) and the CD tray and LD tray become one whole unit.

② Ejecting the LD Tray → Pause (Refer to Fig. 2-9)

After the clamp cam operation, the LD tray, which has become one whole unit with the CD tray, is ejected. While the LD tray is being ejected, the pin on the bottom side of the LD tray comes in contact with the cam (Fig. 2-9 ③) on the right side of the cam plate. The cam plate is then moved to the right from a specified position by the CAS spring and the switch is detected by the cam on the bottom side of the cam plate via the left switch lever.

③ Selecting the CD Tray (Refer to Fig. 2-10)

Similar to “Selecting the LD tray” ①, when the CD plate is forced to the left, the rack assembly which has become one whole unit with the pickup assembly hits the lead edge of the CD plate in the CD mode (CD in playback position) and enters in the ② direction of the clamp cam (Fig. 2-10 ①). The lock plate is then turned to the right and the CD tray is separated from the LD tray. At the same time, the LD tray is fixed to the mechanism base by the lock plate (Figs. 2-10 ② and 2-10 ③).

④ Ejecting the CD Tray to Pause (Refer to Fig. 2-10)

In this case, the LD tray is fixed and only the CD tray is ejected and moved towards the front. When the CD tray has moved into the specified position ④, the cam plate is moved to the right by the cam on the bottom side of the CD tray and the switch is detected as in “Ejecting the LD tray to Pause” ② (Fig. 2-10 ④ and 2-10 ⑤).

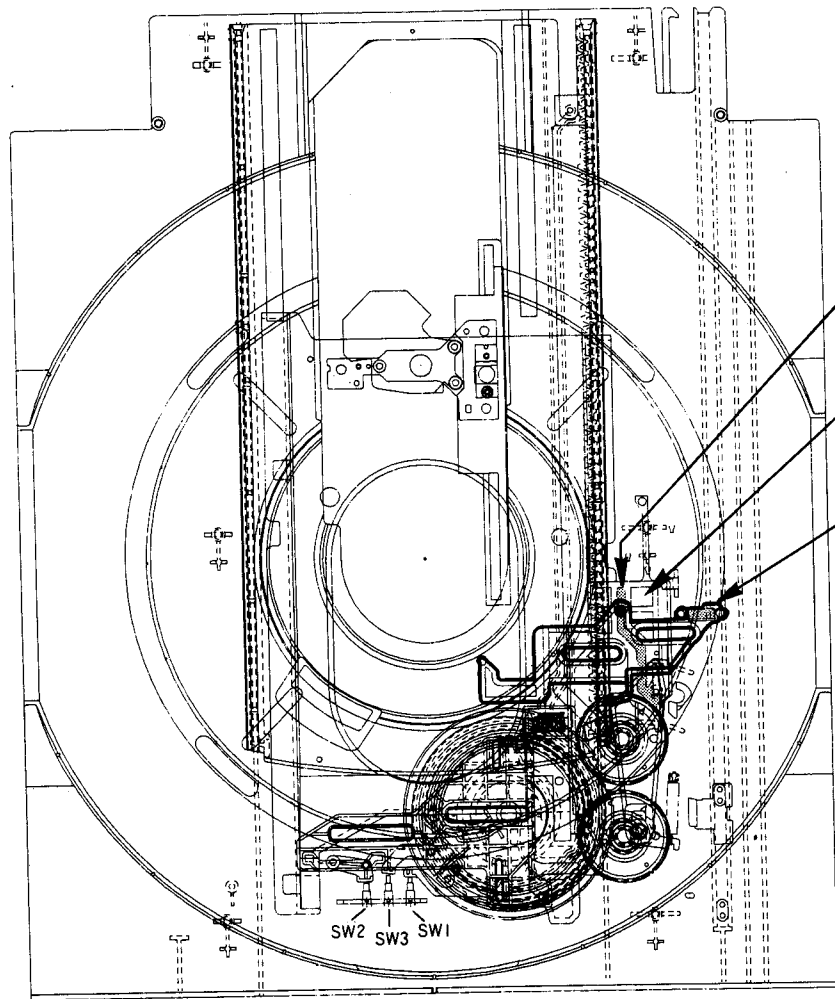

Detection of <<Tray Loading Completed>> switch
(SW1 — ON → OFF)

Fig. 2-9 (a) When Loading the Tray

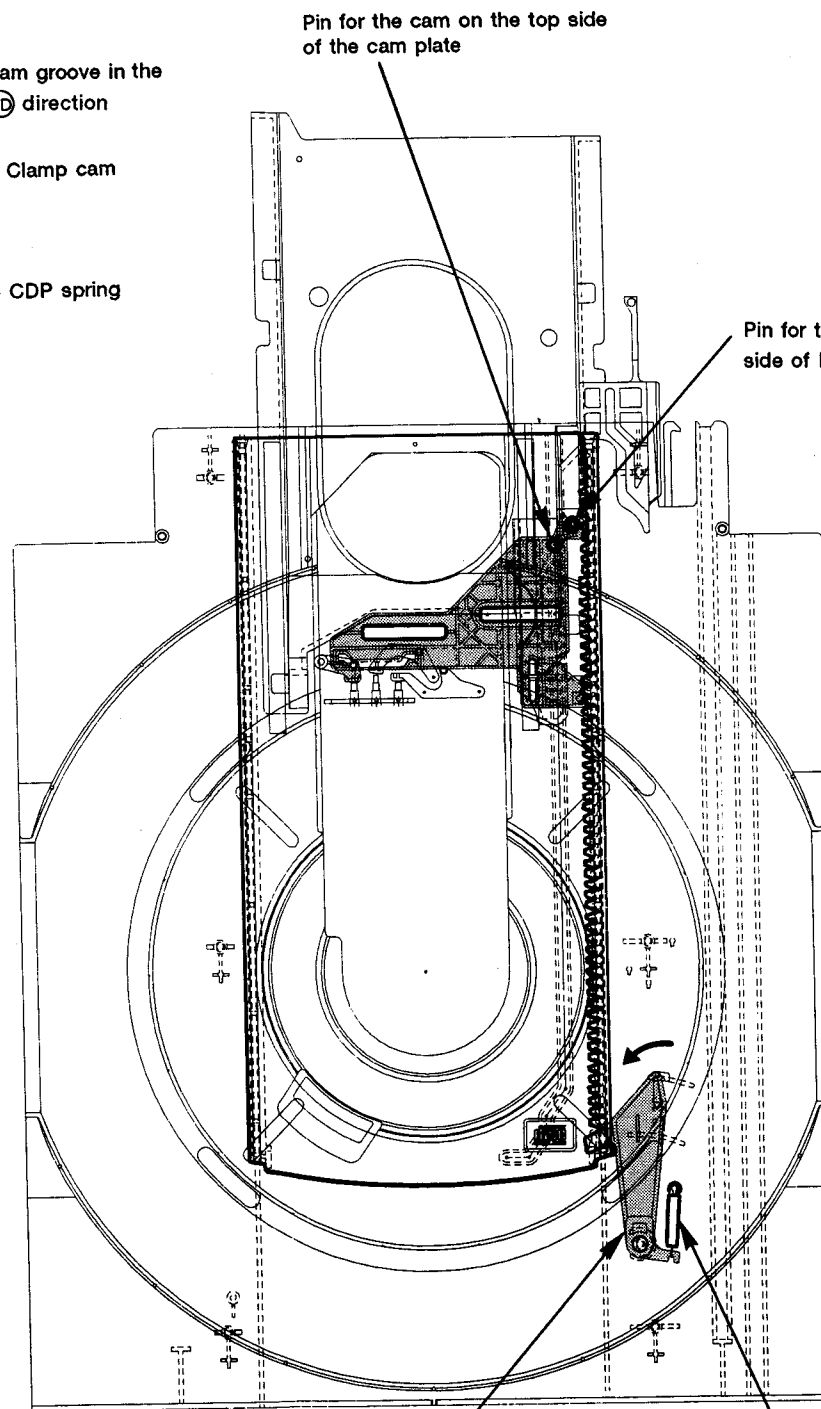

<Tray Open Completed> switch detection check
(fixes the cam plate)

Fig. 2-9 (b) During EJECT

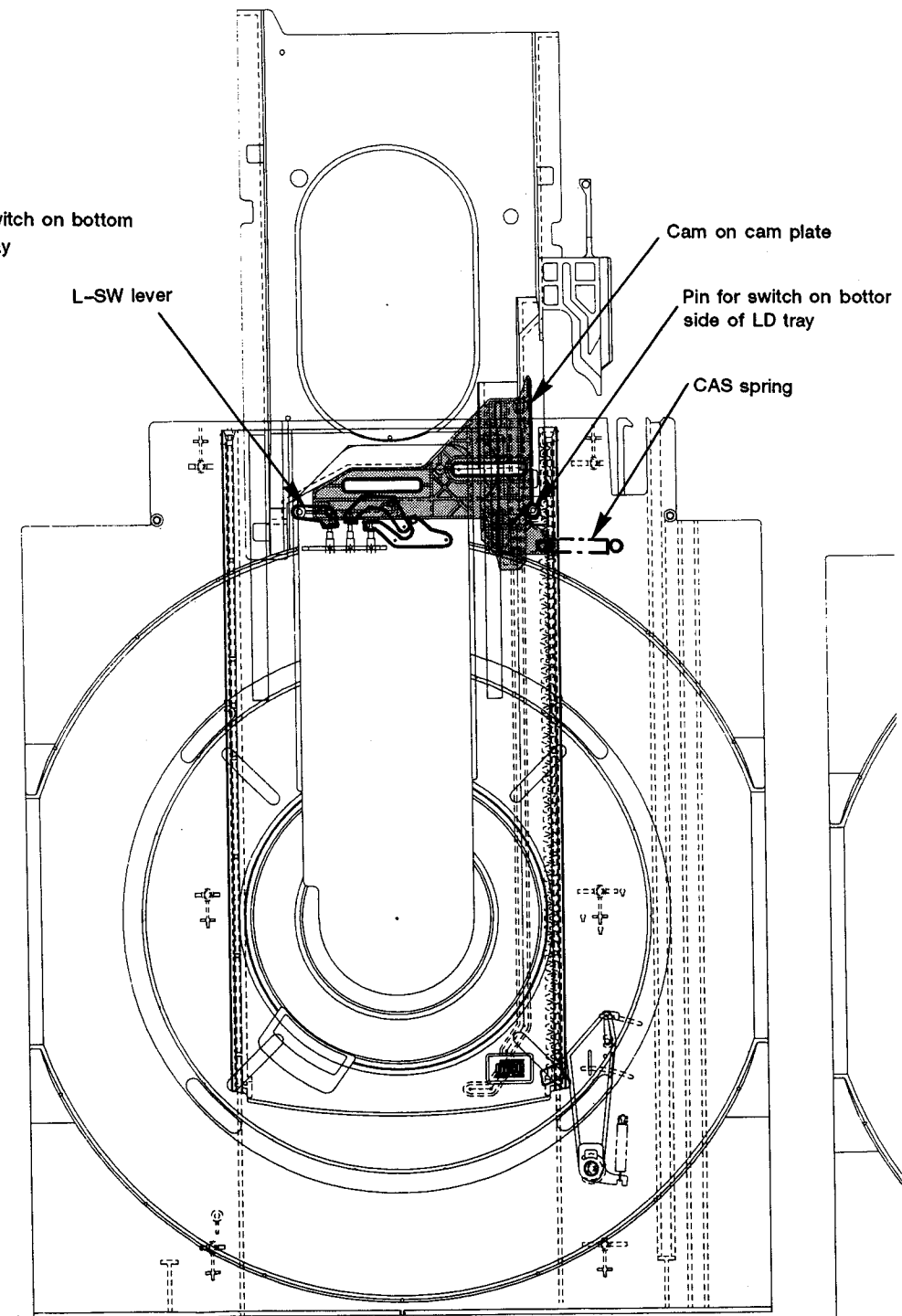

Detection of <<Tray Open Completed>> switch
(SW 3 — ON → OFF)

Fig. 2-9 (c) EJECT <Open Switch> Detection

Schematic Diagram of LD Tray Open/Close Operation

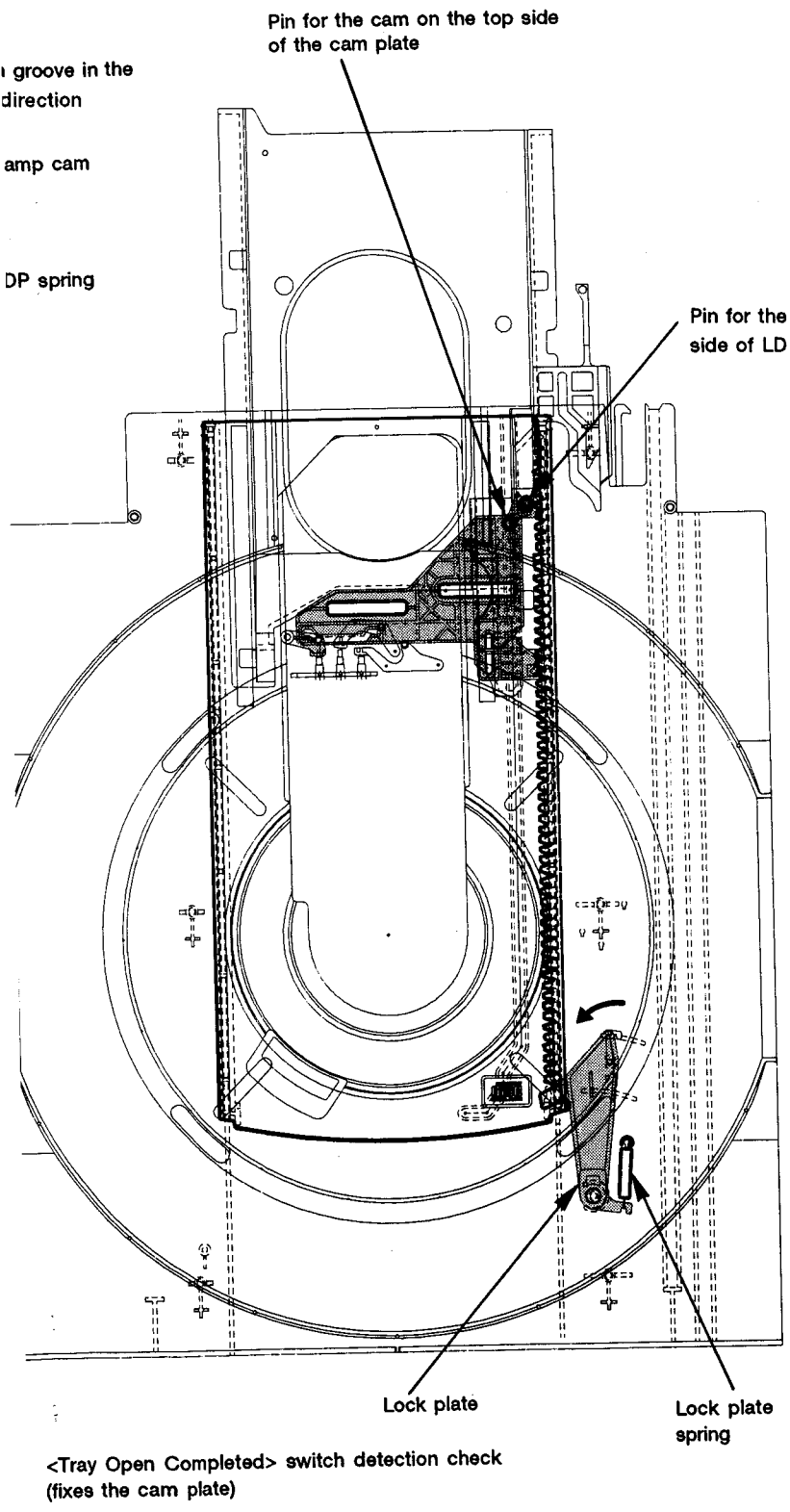

Fig. 2-9 (b) During EJECT

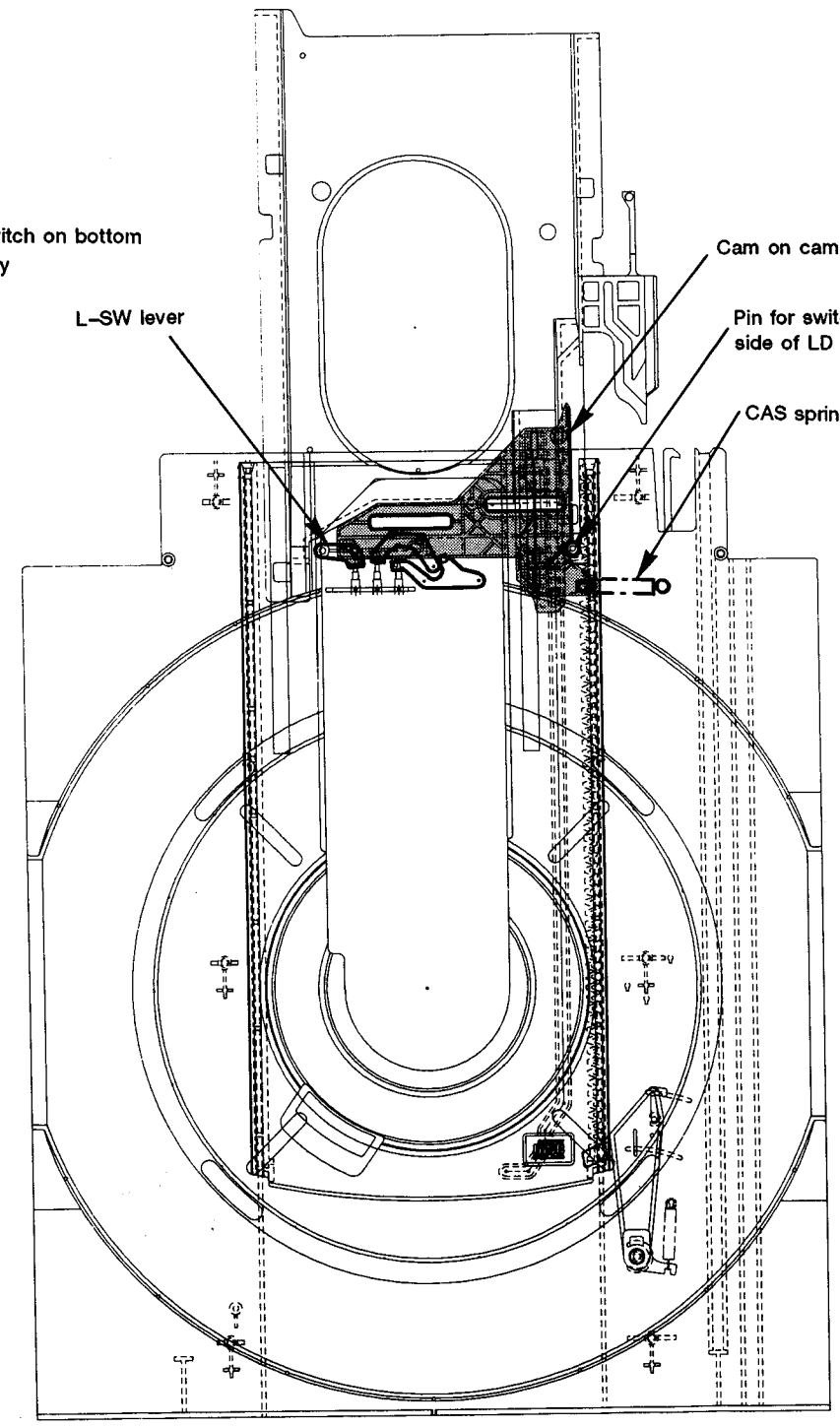

Fig. 2-9 (c) EJECT <Open Switch> Detection

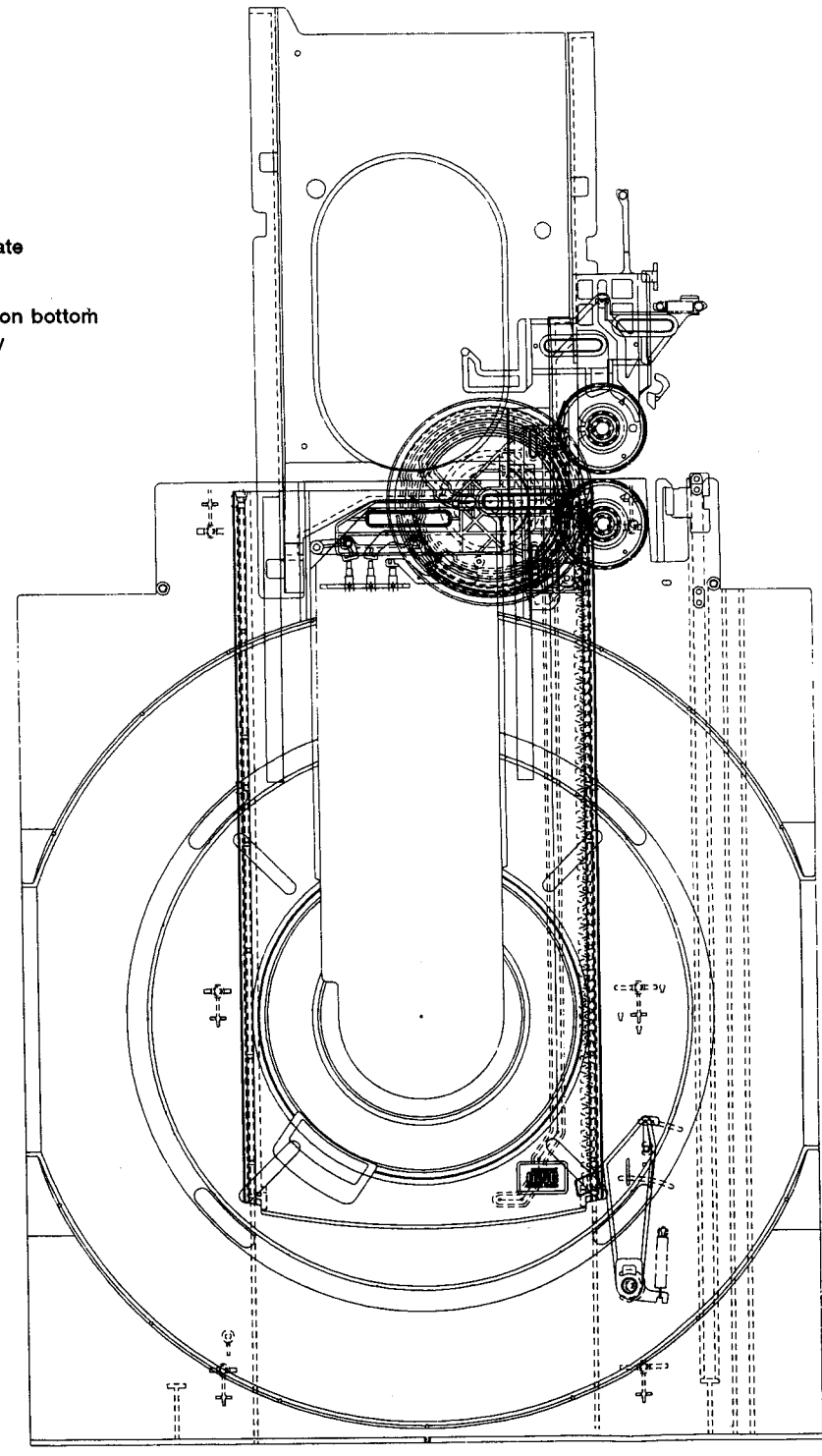

Fig. 2-9 (d) Full OPEN

Schematic Diagram of LD Tray Open/Close Operation

A
B
C
D

A
B
C
D

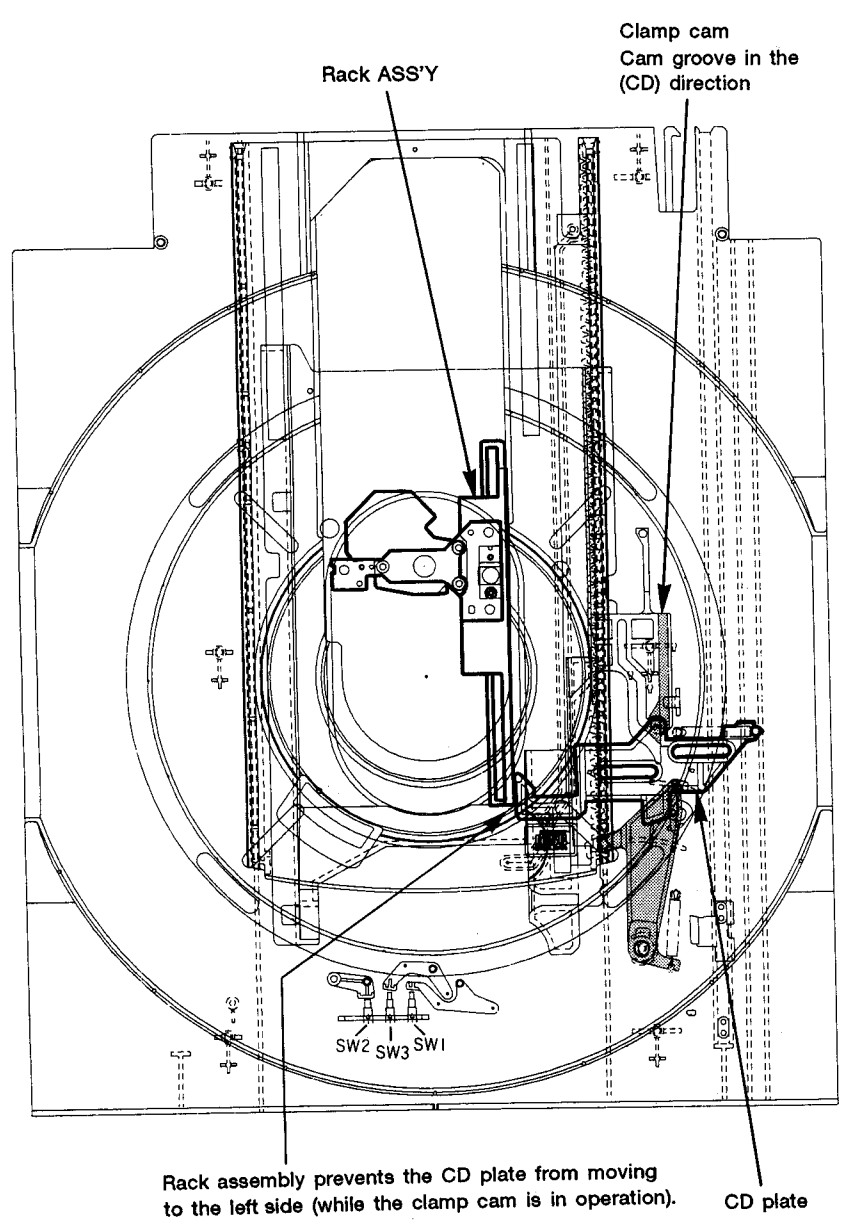

Fig. 2-10 (a) Detection of the CD Mode when Loading the Tray

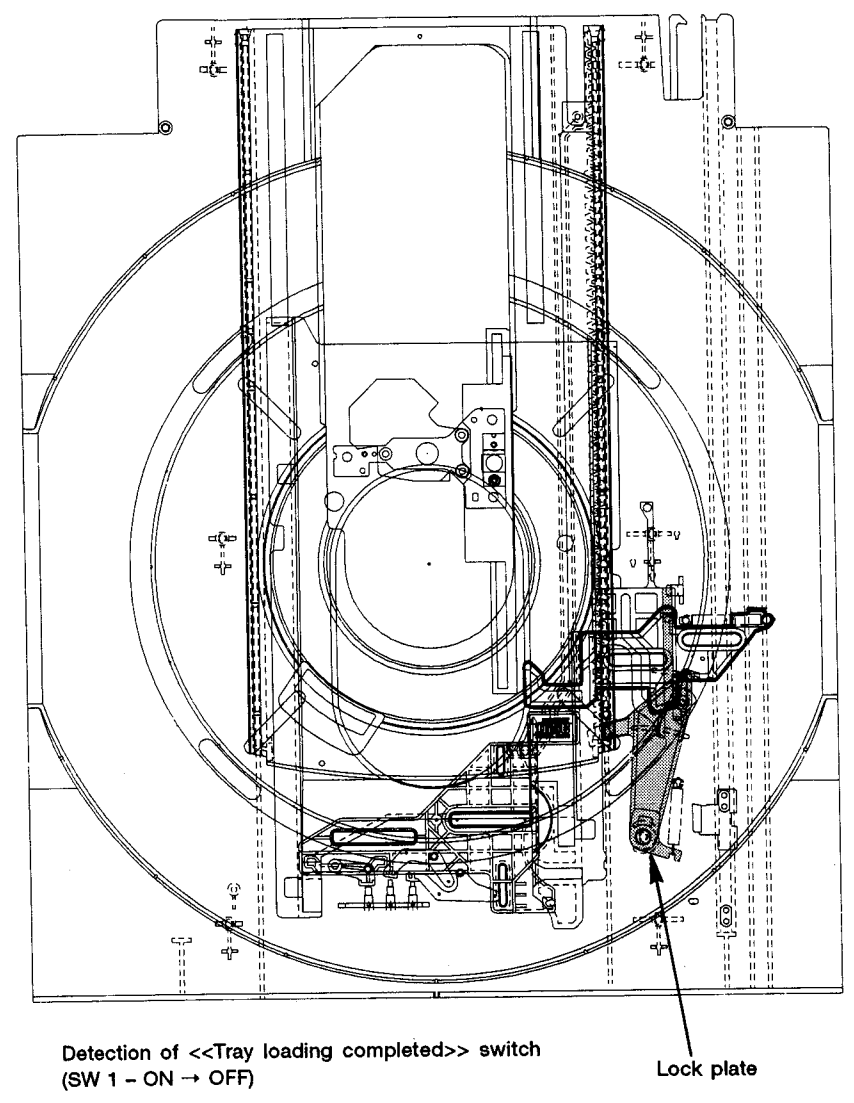

Fig. 2-10 (b) When Loading the Tray

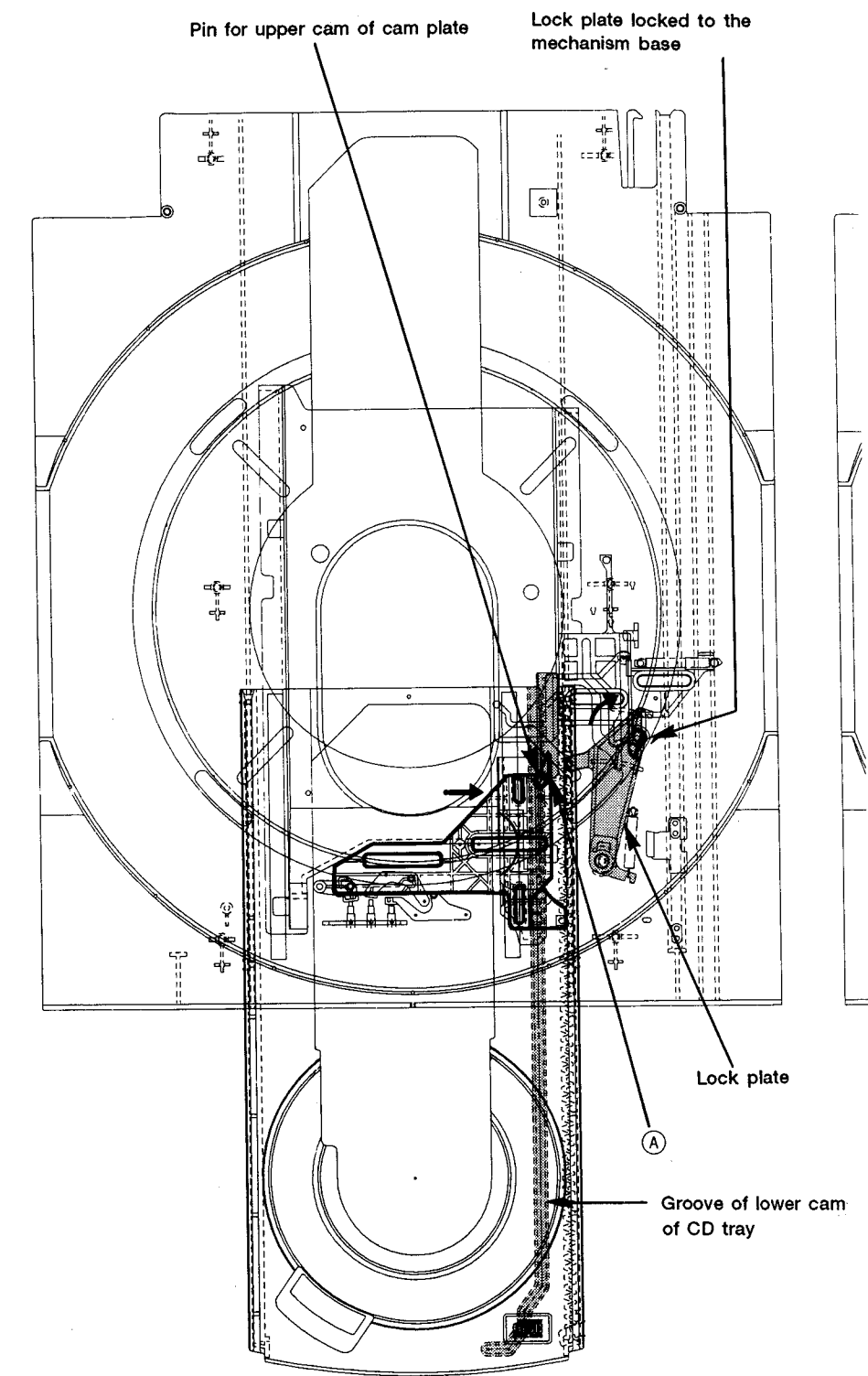
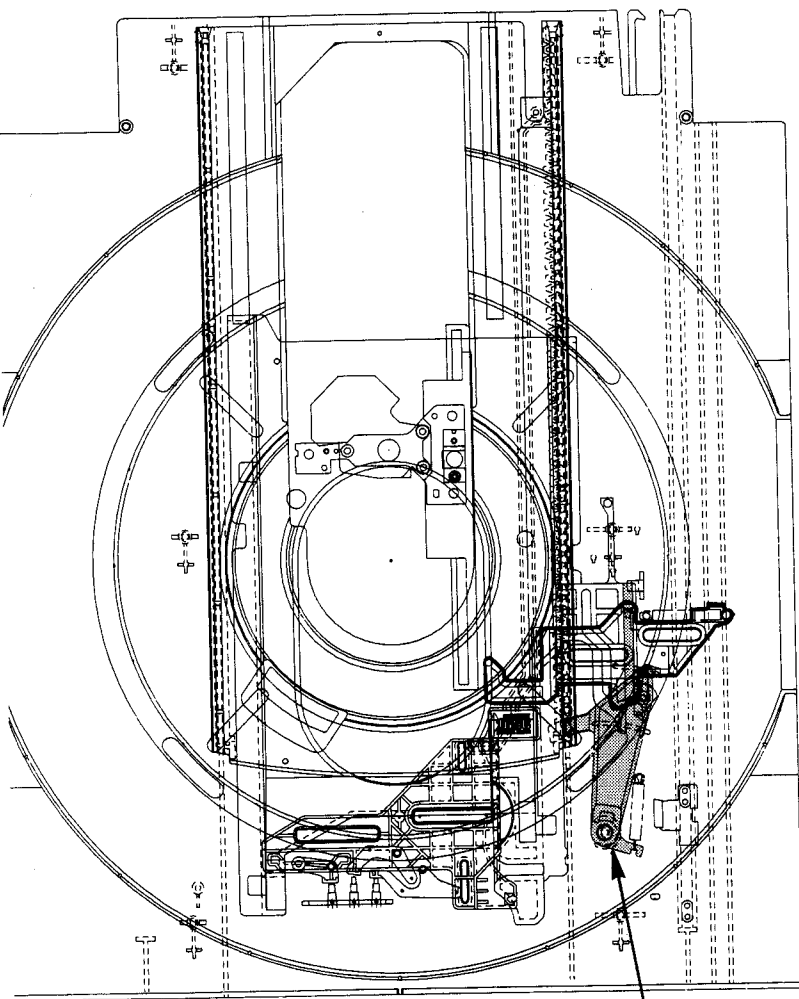

Fig. 2-10 (c) Detection of EJECT <OPEN SW>



Detection of <<Tray loading completed>> switch
(SW 1 - ON → OFF)

Lock plate

Fig. 2-10 (b) When Loading the Tray

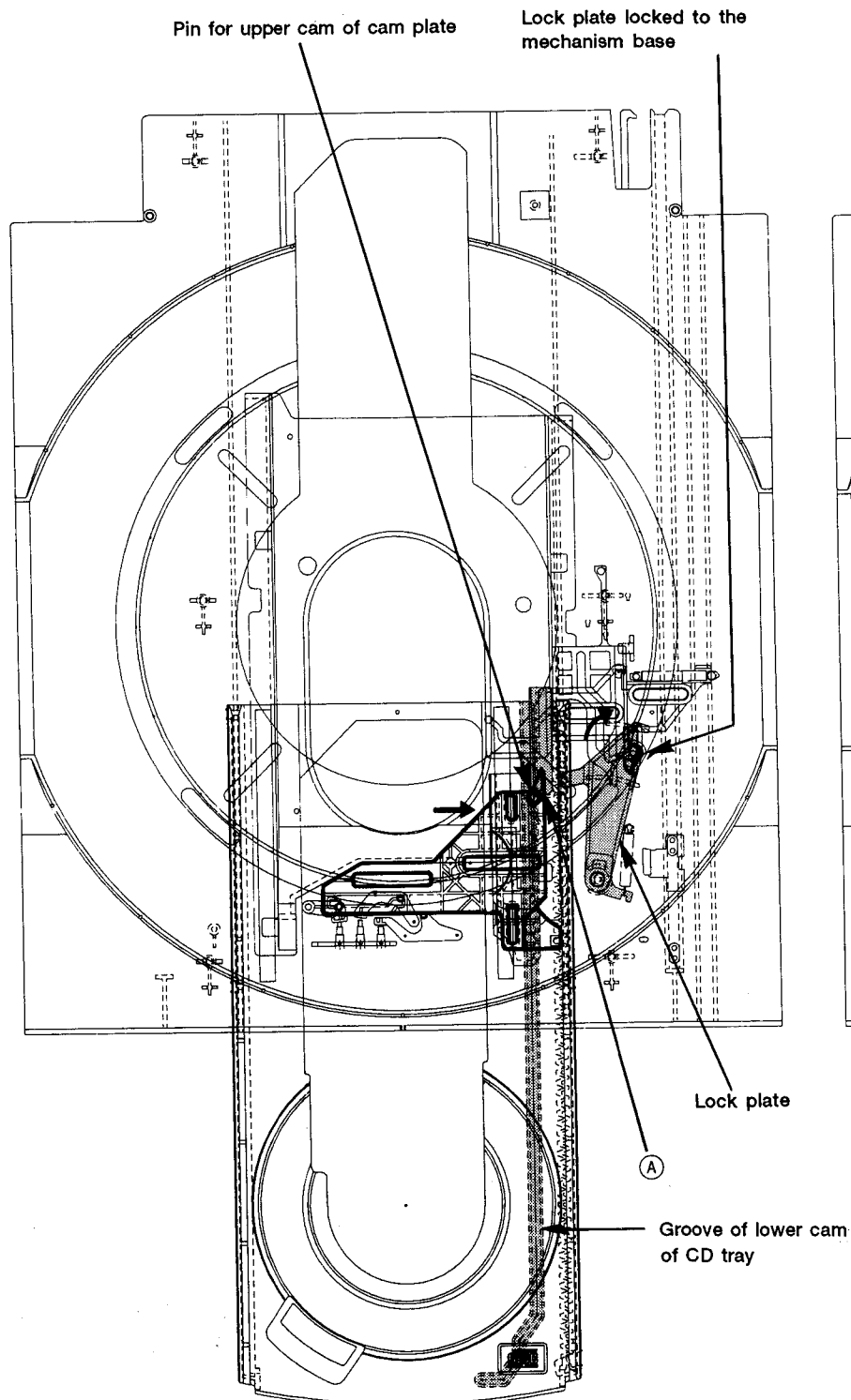

Pin for upper cam of cam plate

Lock plate locked to the
mechanism base

Lock plate

(A)

Groove of lower cam
of CD tray

Detection of <<Tray Opening Completed>> switch
(SW 3 - ON → OFF)

Fig. 2-10 (c) Detection of EJECT <OPEN SW>

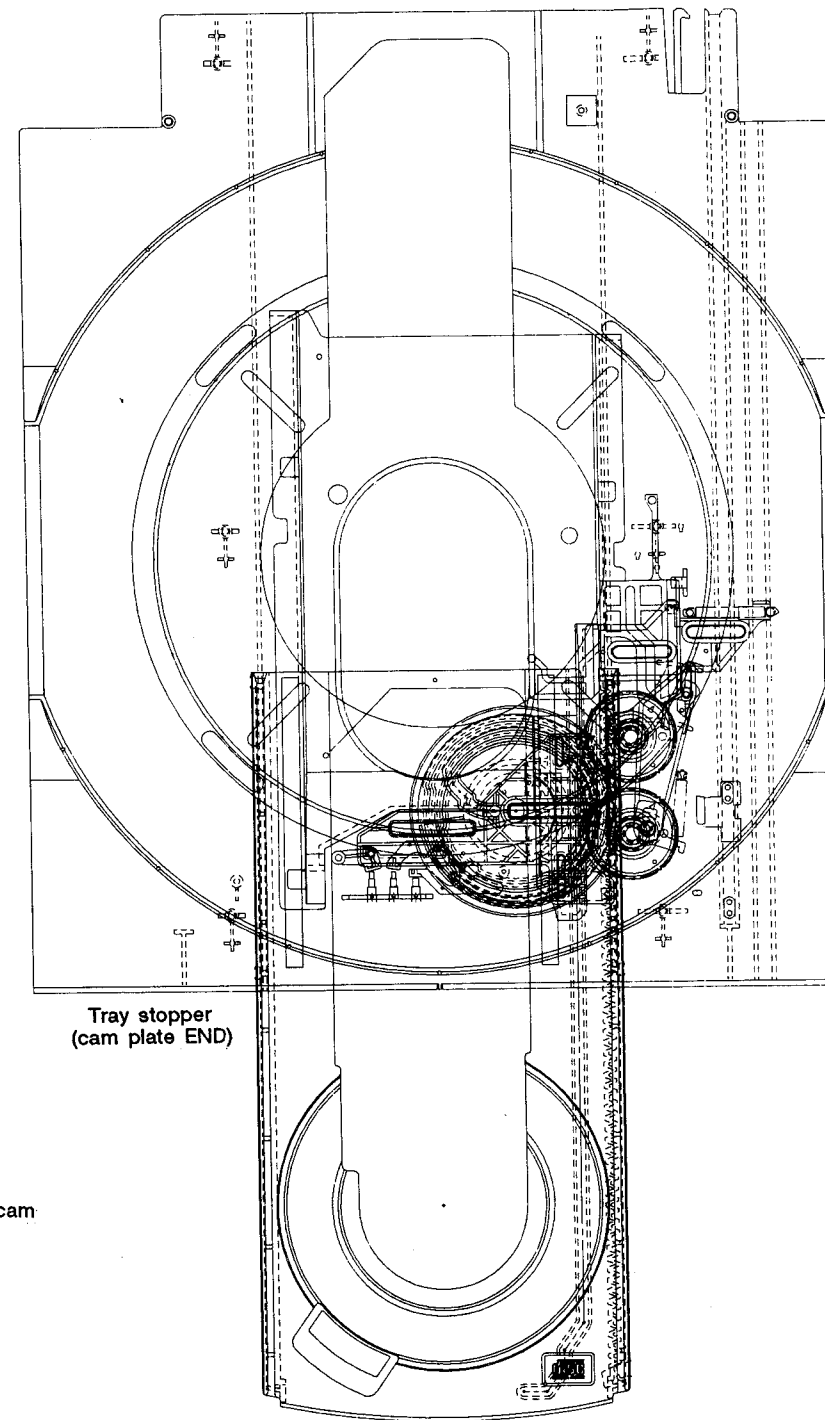

Tray stopper
(cam plate END)

Fig. 2-10 (d) Full OPEN

A

B

C

D

3) Each mode of Mechanism

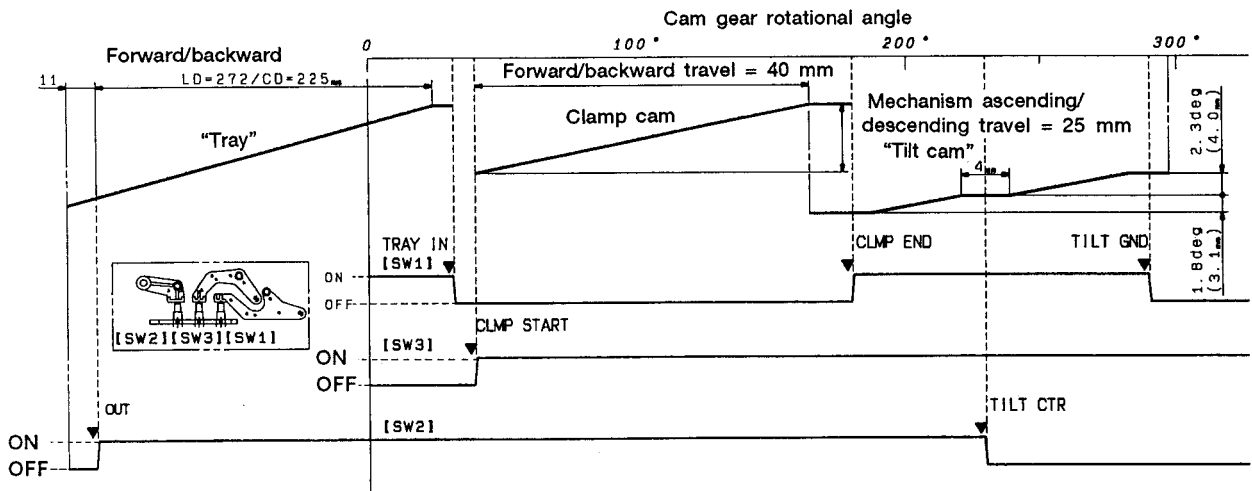

Fig. 2-11 Each mode of Mechanism

3. DESCRIPTION OF THE SYSTEM CONTROL

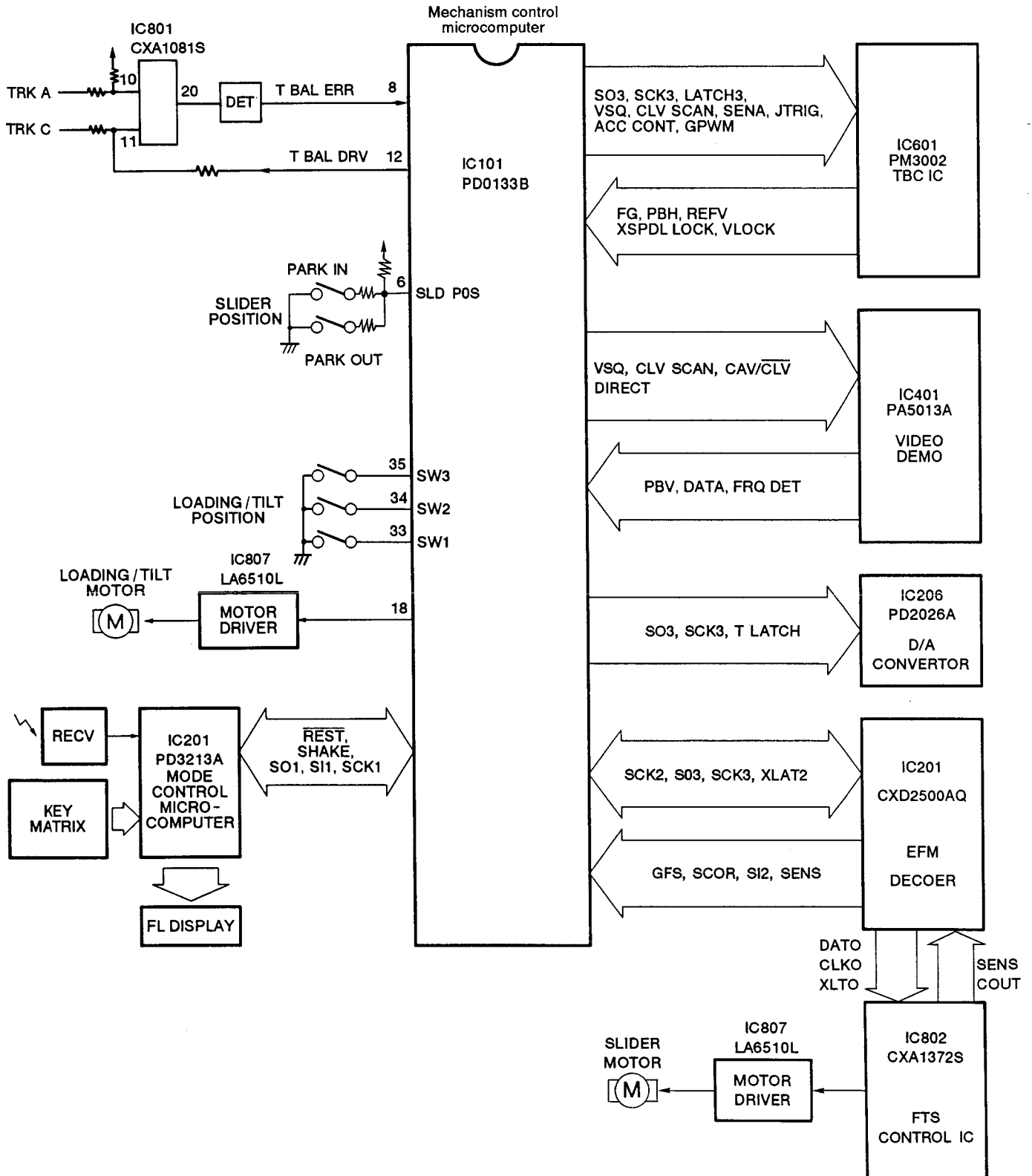

Fig. 3-1 Block diagram of the control system

3.1 MICROCOMPUTER INTERFACE

The microcomputer system of this model consists of two chips, an 8-bit microcomputer (IC101: PD0133B) which controls the mechanism and a 4-bit microcomputer (IC201: PD3213A) which controls the operations and displays.

These two microcomputers are connected via a serial interface. The communication lines are also used for controlling the character generator IC (IC405: PD0093A).

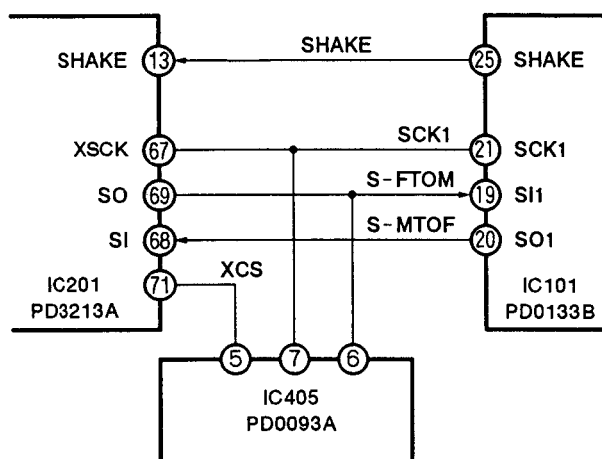

Fig. 3-2 Serial interface connection

3.2 MICROCOMPUTER COMMUNICATION SEQUENCE

1. The PD0133B sets the SHAKE terminal (pin 25) to "L" for several microseconds as a request to the PD3213A for the start of a communication.
2. When the PD3213A receives the communication start request, it sets the SHAKE terminal (pin 13) to "L" and informs the PD0133B that it is ready for communication.
3. The PD0133B then sets SCK1 (pin 21), which has been used as an input port, to output mode. The PD3213A sets XSCK (pin 67) to the input mode, connecting the communication lines between the microcomputers.
4. The PD0133B sends the transfer clock (500KHz) in 8 bits. The data are then sent and received in synchronization with this clock.

5. When PD3213A receives data of 8 bits, it sets the SHAKE terminal (pin 13) to "H" and reports that a single communication is completed.
6. The PD0133B sets SCK1 (pin 21) to input mode, and the PD3213A sets XSCK (pin 67) to output mode. The communication line is thereby disconnected and a single communication is completed.

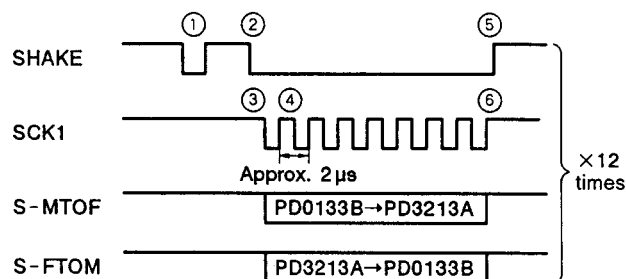

Fig. 3-3 Timing chart of the microcomputer interface

- The communication takes place within a cycle between 10 and 30 ms. Twelve bytes of data are transmitted at one time.
- The handshake is done on a single line. Both the PD0133B and the PD3213A use a single port for both input and output. The port is set to output mode when the output is "L". In other conditions, it will be set to input mode (high impedance). Before "L" is output, both ports mutually confirm that the SHAKE terminal is "H". This is to prevent signal interference between tray output signals.
- The communication data is appended with a check code to prevent transfer errors. If sixteen consecutive transfer errors are detected, the PD3213A will send the reset signal to the PD0133B to reset it to its initial state. This will also happen when the communication is not executed for 300 ms or longer.

3.3 OUTLINE OF THE MECHANISM CONTROL SYSTEM

1) Processing immediately after power ON

When power is applied, the mechanism-control micro-computer (IC101: PD0133B) will execute initialization in the following sequence upon reset cancellation (pin 28: L to H).

1. The internal RAM and ports are initialized.
2. The CXD2500AQ is initialized.
3. The tray position is detected.
4. The FTS-IC CXA1372S is initialized.
5. The TBC-IC PM3002 is initialized.
6. Communication with the PD3213A is confirmed.
(If any trouble is found, the subsequent initialization procedures will not be performed.)
7. The pickup position is initialized.
8. Disc rotation stops.
9. Loading mode is initialized.

After all the initialization procedures are completed, normal operations can begin.

2) Control of the loading motor

Driving of the loading motor is controlled by a PWM signal supplied via the OP amplifier (IC807) from pin 18 of the mechanism-control CPU (IC101) in the CONT section. The voltage applied to the loading motor is switched according to the duty of the PWM signal as follows. The PWM cycle is approximately 910 μ sec.

• Loading/clamp operation

For the disc tray open/close and disc clamp and stop operations, the motor is operated while the position of the cam gear is detected by the loading/tilt-position detection switch connected to pins 33 through 35 of the IC101.

• Tilt servo operation

When an LD disc or a CDV disc (video portion) is played back and when a CDV disc is started up, the loading motor is used for the tilt servo. The loading motor is driven by a PWM drive in this mode as well.

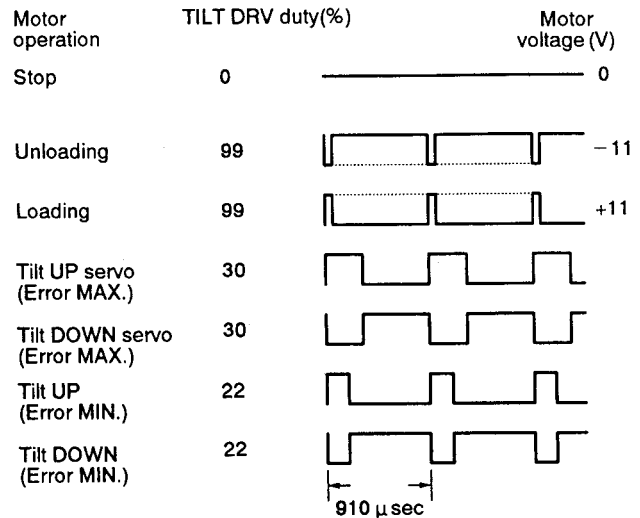

Fig. 3-4

The tilt servo operates the loading motor so that the input voltage at pin 9 (TILT ERR) of the IC101 becomes 2.5 V.

The tilt servo operates in the following ranges during normal playback.

- CAV disc (12-inch) : Frames 0 – 40999
- (8-inch) : Frames 0 – 16999
- CLV disc (12-inch) : 0 min. – 44 min. 59 sec.
- (8-inch) : 0 min. – 13 min. 59 sec.
- CDV disc (video portion) : 0 min. 0 sec. –
(Recording time – 1 min. 23 sec.)
- CD disc : The tilt servo is ON only at start-up.

If some trouble occurs with the disc or tilt sensor circuit which prevents the input voltage at the TILT terminal from being within the specified range even if the pickup inclines to more than $\pm 2^\circ$ (degrees), the loading motor will be stopped upon detection of the state of the mechanism switch.

The tilt servo switches the duty of the PWM signal in 2 levels according to the error value. When the error value is small (1.25 V – 3.75 V), a PWM signal for small duty 22% is output, and when the error value is large (0 V – 1.25 V, 3.75 – 5 V), a PWM signal for large duty 30% is output. (See Fig. 3-4.)

• Automatic tracking balance operation

The tracking balance error signal is obtained firstly by detecting the waves, for both the top and bottom sides at the time of TRK open, of the tracking error signals output from CXA10815 (IC801 (20) pin) then by adding them. This error signal, after being smoothed and level-converted, is input as the TBAL ERR into the IC101 (8) pin. After the duty pulse, that is based upon this error is output from the IC101 (12) pin and smoothed, it is then added to the IC801 (11) pin TRK C side so that the tracking balance becomes 0V center. Every time a disc is started up the tracking balance is obtained in between the tracking open distance and then maintains the voltage thereafter. It always operates at the time of tracking open in the test mode.

3) Slider motor control

The mechanism-control IC (IC101) controls the drive signal output from pin 20 of the FTS servo IC CXA1372S (IC802) by the serial command.

The voltage applied to the slider motor is switched according to the duty of the PWM signal as follows. The PWM cycle is 36mS.

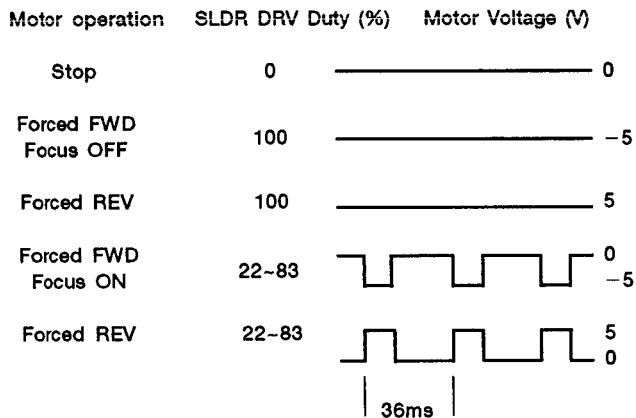

Fig. 3-5

4) Audio control

Digital audio channel switching is performed by the CXD2500AQ by using a command from the microcomputer.

DIGITAL 45	SQ1 14	SQ2 13	L - ch Line Out	R - ch Line Out
L	L H L H	L L H H	Analog L ch Analog L ch Analog R ch Mute	Analog R ch Analog L ch Analog R ch Mute
H	L	L	Digital L ch Digital L ch Digital R ch Digital - 12dB - L	Digital R ch Digital L ch Digital R ch Digital - 12dB - L

Table 3-1

• SLDR POSITION

* The following positions can be detected by using two switches in combination.

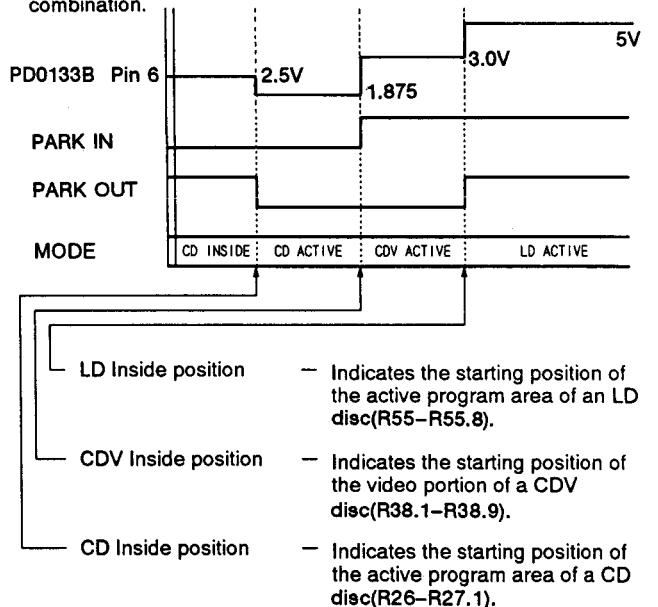

R: The distance from the center of the spindle motor.

Fig. 3-6

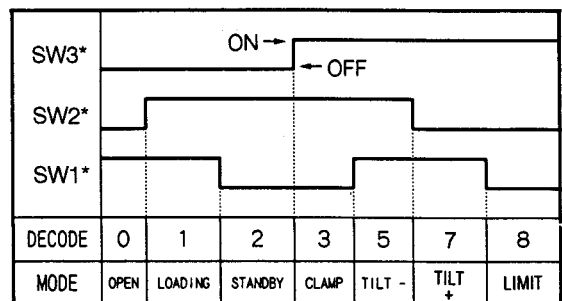

*For the places where SW1 - SW3 are attached, refer to Figure 2-10 (a).

Fig. 3-7 LOADING / TILT POSITION

5) Direct CD Mode

When the direct CD switch is turned ON for CD playback, the following operations are performed (controlled by a microcomputer).

1. The power supply to the video system which is not required for CD playback is turned OFF. (No picture is obtained.)
2. The self-illuminating switch lights, and direct CD mode is activated.
3. The slider changes its park position for starting up a CD.
4. If the tray is in the closed condition, the CD tray will also open when the tray opens.

With these operations, the time required from the pressing of the PLAY button to the start of the CD playback can be shortened to 2/3. In addition, purer audio playback is possible by turning off the unnecessary power supply. Direct CD mode cannot be activated in LD playback or when an LD is set.

When LD playback is started in direct CD mode, the mode is automatically canceled to enable normal LD play back. Direct CD mode can be selected in playing back the video portion as well as the audio portion of the CDV disk.

Disc	Direct CD	Video System Power	Tray Open
CD	ON	OFF	CD Tray
CD	OFF	ON	LD Tray
LD	OFF	ON	LD Tray
CDV video portion	OFF	ON	LD Tray
CDV video portion	ON	ON	CD Tray
CDV audio portion	ON	OFF	CD Tray
CDV audio portion	OFF	ON	LD Tray

Table 3-2

6) CLV Clear Scan

Clear scan without picture distortion is possible also for CLV discs by using the shuttle ring (either on the player or the remote control unit).

The conventional color-lock scan and the clear scan can be switched depending on the angle of the shuttle ring rotation. In a clear-scan operation, scanning is performed while outputting digital audio at -12 dB (the same as scanning on CD). (No audio is output when analog audio is selected.)

The principle of the operation is as follows.

1. When clear scan mode is activated, the specified number of tracks is skipped in a multitrack jump operation.
2. Measures the time lag (phase difference) between PB - V and REF - V and when the measured value is within a certain range, decreases REF - H by 7 H until the phase difference between PB - V and REF - V is lost (VLOCK), then cancels squelch, displaying the video portion of the disc for a certain period. Returns to step 1 and repeats steps 1 and 2.

When the time lag between PB - V and REF - V exceeds a certain range, performs a 1-track jump (2-track jump in the REV direction) and measures the lag again. When the measured value is within a certain range, decreases REF - H by 7 H waiting for VLOCK between PB - V and REF - V. Otherwise, repeats a 1-track jump and time-lag measurement.

If the time lag does not enter a certain range even after repeating the 1-track jump and time-lag measurement operation three times, a multitrack jump is performed for a larger skip and is repeated step 2 from the beginning.

If the lag persists in not entering a certain range, VLOCK wait state is activated.

- * Gray-background video is output when no disc video is supplied.
- * Digital audio to be played during clear scan is output while the disc video is being supplied and in VLOCK wait state.
- * For CAV discs, nearly the same operation is performed.
- * PB - V (playback V) means V - sync of the playback video signal.
- * REF - V (reference V) means V - sync used as the reference.
- * VLOCK means the signal generated when the PB - V and REF - V are in a certain range.

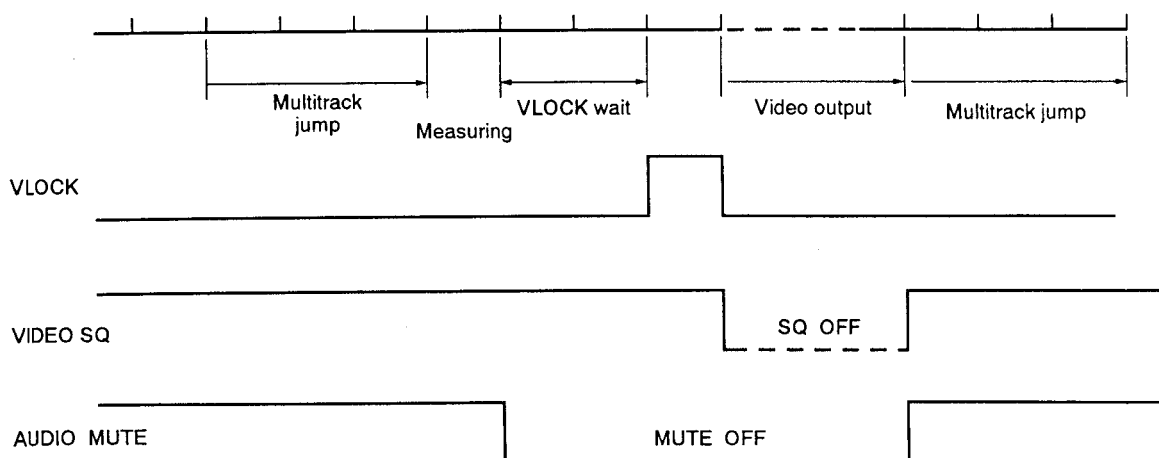
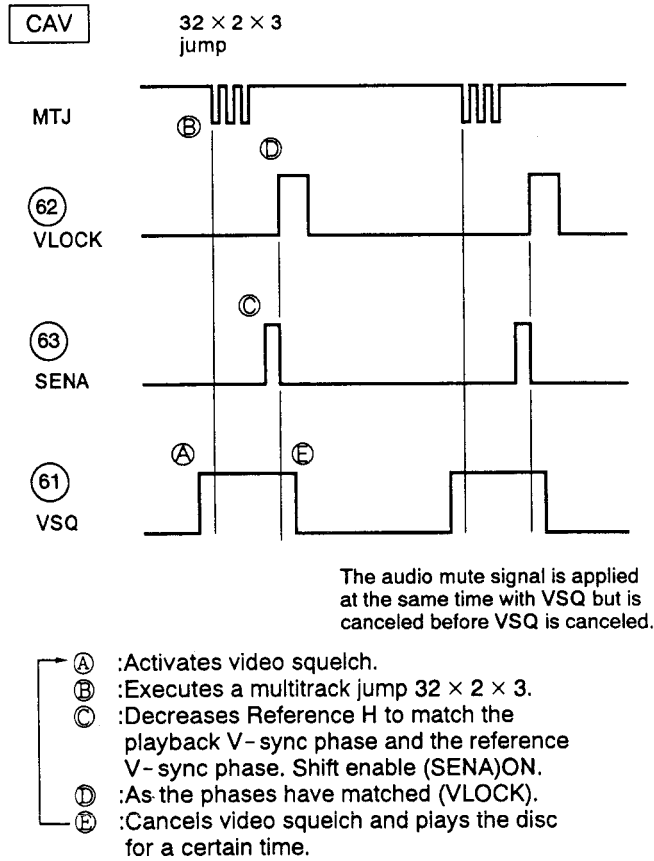

Fig. 3-8

● Timing Chart of the Clear Scan



CLV
Compared with CAV, a longer time is required to match the phases after a jump operation. Ⓒ

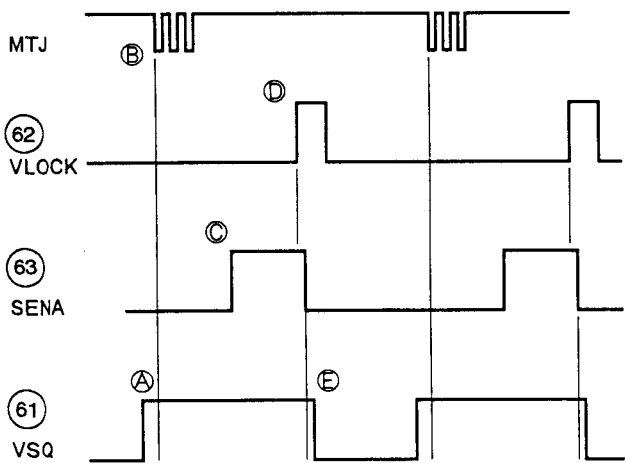

Fig. 3-9

● Timing Chart of the Normal Scan

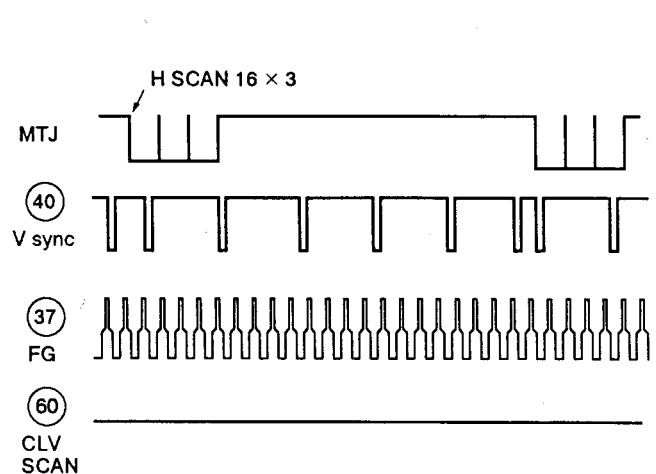
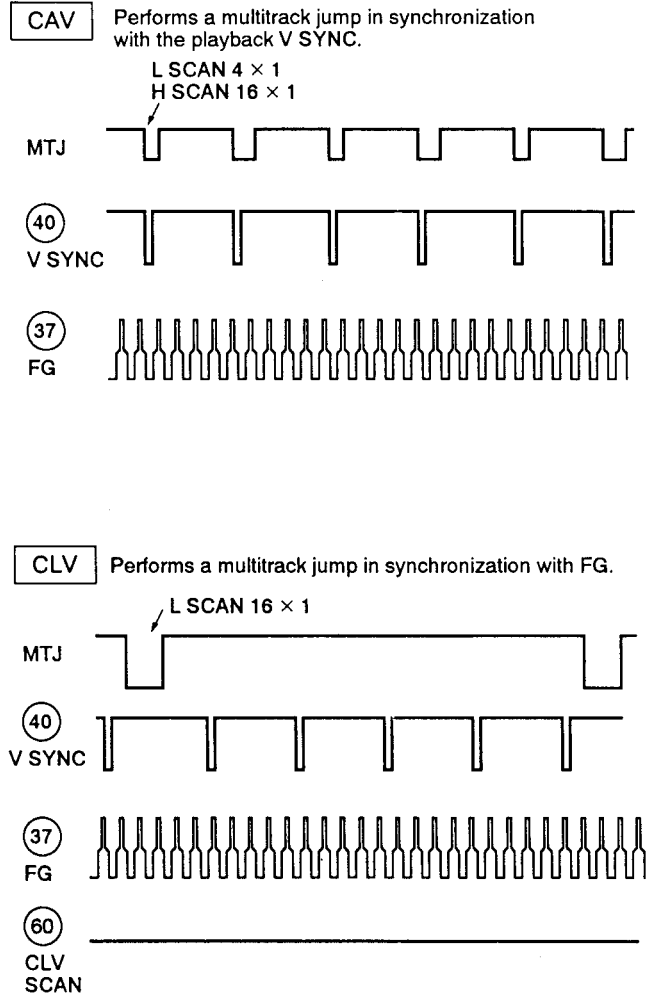

Fig. 3-10

7) Description of the Mechanism-control IC (IC101: PD0133B)

No.	Pin name	I/O	Function
1	VCC	-	Power supply connection pin. Set to 5 V \pm 10%.
2	DIRECT	O	CD DIRECT video system power OFF signal output pin "H" = video system power OFF, "L" = ON
3	CAV/XCLV	O	CAV/CLV switching signal output pin "H" = CAV, "L" = CLV Connected to Pin 6 of PA5013A and used as a VIDEO NR switching signal.
4	XLD ON	O	Laser video ON/OFF switching signal output L: ON, H: OFF
5	TGH	O	Tracking operation control signal output pin The control signal supports ON/OFF of the tracking servo-mechanism operation. "H" = OFF, "L" = ON
6	SLDR POS	I	Pick-up position detection switch input pin (analog signal) Divides the resistance among the switches, reads the value of the A/D input, and detects the position.
7	FREQ DET	I	RF detection signal input pin (analog signal) Inputs the A/D conversion of the RF detection output and is used in the spindle luff servo-mechanism. Voltage and frequency are proportional.
8	TBAL ERR	I	Tracking balance error signal input pin (analog signal) Signal is A/D converted and is input as the tracking offset control.
9	TILT ERR	I	Tilt sensor output signal input pin (analog signal) Inputs (0 to 5 V) the tilt sensor output amplified to a 40 to 50 dB signal. The signal is A/D converted and is input as the tilt sensor control. Controls the tilt motor until the signal is 2.5 V.
10	XREF-V	I	Clear scan reference V-SYNC signal input pin
11	GFS	I	CD (EFM signal) frame lock signal input pin Connected to Pin 12 of the EFM decoder IC: CXD2500AQ. "H" = Lock, "L" = Unlock GFS is an abbreviation for Good Frame Sync.
12	TBAL DRV	O	Tracking offset control signal output pin Outputs the tracking offset after PWM and is used in auto tracking offset. Cycle: 910 μ sec; 3-value control H, L, Z.
13	SQ2	O	Analog audio switching signal output pin 2/R Squelch: H
14	SQ1	O	Analog audio switching signal output pin 1/L Squelch: H When in digital audio mode, the signal is output through the control of the EFM decoder IC: CXD2500AQ.
15	SI2	I	EFM decoder IC: CXD2500AQ subcode input pin Reads the subcodes of SCK2 and the signal.
16	XLAT2	O	EFM decoder IC: CXD2500AQ control latch signal output pin Sends the control command using SO3 and 2500CLK.
17	SCK2	O	EFM decoder IC: CXD2500AQ subcode read clock signal output pin Sets the clock to 96 and reads the subcode.

No.	Pin name	I/O	Function
18	TILT/ LOAD DRV	O	Loading and tilt control signal output pin Output in PWM format to control loading and tilt servo-mechanism.
19	S-FTOM	I	Input pin of data from the mode control IC Serial Used with the data signal to the carriage generating IC.
20	S-MTOF	O	Serial data output to the mode control IC Serial
21	SCK1	I/O	Clock for serial communication with the mode control IC In the input mode except during serial communication with the mode control IC Used with the clock signal to the carriage generating IC
22	SENS	I	SENS signal input pin All of the following signals from 2500 are switched and are output to the signal: SEIN, FZC, A.S, TZC, XBUSY, FOK, GFS, COMP, COUT, and OV64.
23	SCOR	I	Subcode SYNC signal input pin Inputs the subcode signal from the EFM decoder IC: CXD2500AQ when the signal is "H." Supervises the disc playback depending on the presence of the signal.
24	XCX	O	Analog audio CX noise reduction switching signal output pin ON: L, OFF: H
25	SHAKE	I/O	Pin of hand shake signal for data communication with the mode control IC This pin is a bi-directional data path which sends the data transfer timing through the I/O mode switching of the respective microcomputers.
26	XPBV	I	LD/CDV playback V-SYNC signal input pin IC basically operates in sync hronization (rising and leading edges) with the signal. Setting the signal as standard in the special CAV playback mode, generates jump timing. "L"= V-SYNC ongoing
27	CN VSS	-	GND for A/D conversion
28	XRESET	I	Reset signal input pin "L" = Reset, "H" = Cancel reset
29	XTAL IN	I	9 MHz clock generation input pin
30	XTAL OUT	O	9 MHz clock generation output pin
31	N. C.	O	Not used
32	VSS	-	GND
33	SW1	I	Loading/tilt position detection switch input pin
34	SW2	I	Loading/tilt position detection switch input pin
35	SW3	I	Loading/tilt position detection switch input pin
36	N.C.	I	Not used Processing needed when used for input
37	FG	I	Spindle motor-FG signal input pin 24 pulses per signal Divided into thirds and used inside the microcomputer.
38	DATA	I	Input pin for Philips code decoder in the mechanism controller
39	XPBH	I	Playback H-SYNC input for Philips code decoder
40	XPBV	I	Playback V-SYNC input for Philips code decoder

No.	Pin name	I/O	Function
41	GI. MIRR	O	False MIRR signal output pin to jump 1 track for LD.
42	N.C.	-	Not used
43	N.C.	-	Not used
44	MUTE	O	Audio system audio mute control output pin "H" = MUTE ON, "L" = MUTE OFF
45	XANA	O	Digital/analog audio switching signal output pin "H" = digital, "L" = analog Signals output by the line out and headphone are switched by the signal.
46	XT LATCH	O	DAC & Digital PD2026 serial control latch signal output pin
47	N.C.	-	Not used
48	N.C.	-	Not used
49	N.C.	-	Not used
50	2500CLK	O	2500 command clock signal output pin The commands for 2500 are the following: 2500CLK; SO3 and XLAT2.
51	RFCORR	O	RF correction switching signal output pin "H" = gain up. Increases gain (#8000 to #8100) within the CAV.
52	SCAN CONT	O	TBC control signal output pin H: multi-track jump ongoing, L: others
53	CD	O	CD/LD switching signal output pin H: CD, CDV-A, L: LD, CDV-V
54	ACC CONT	O	Spindle acceleration signal output pin H= acceleration, L= deceleration, Z= CD, stop, and play
55	GPWM	O	Spindle gain switching duty pulse signal output pin CLV inner circumference: L, outer circumference: H, CAV: L, CDV: H
56	J.TRIG	O	Track jump signal output pin Used for single track jump H: start of track, L: others, Width of "H": approx. 20 μ sec
57	SCK3	O	Serial 3 clock signal output pin Reads the leading edge "H" = within 2 μ sec, "L" = within 20 μ sec
58	SO3	O	Serial 3 data signal output pin With the serial signal as the common signal, divides the signals into three types of latch signals (XLAT3, XLAT2, and XT LATCH). LSB first
59	XLATCH3	O	Spindle servo-mechanism IC latch signal output pin
60	CLV SCAN	O	CLV V-SYNC scan mode signal output pin
61	VSQ	O	Video output switching signal output pin "H" = squelch, "L" = playback video
62	VLOCK	I	V-SYNC lock detection signal input pin. Is used in CLV clear scan and is set to "H" for a period of time if the REF-V is in phase with PBV.
63	SENA	O	Shift enable signal output pin. Is used in CLV clear scan. Thinning out H, is set to "H" while REF-V approaches PBV.
64	XSLOCK	I	Spindle lock signal input pin L: lock, H: unlock

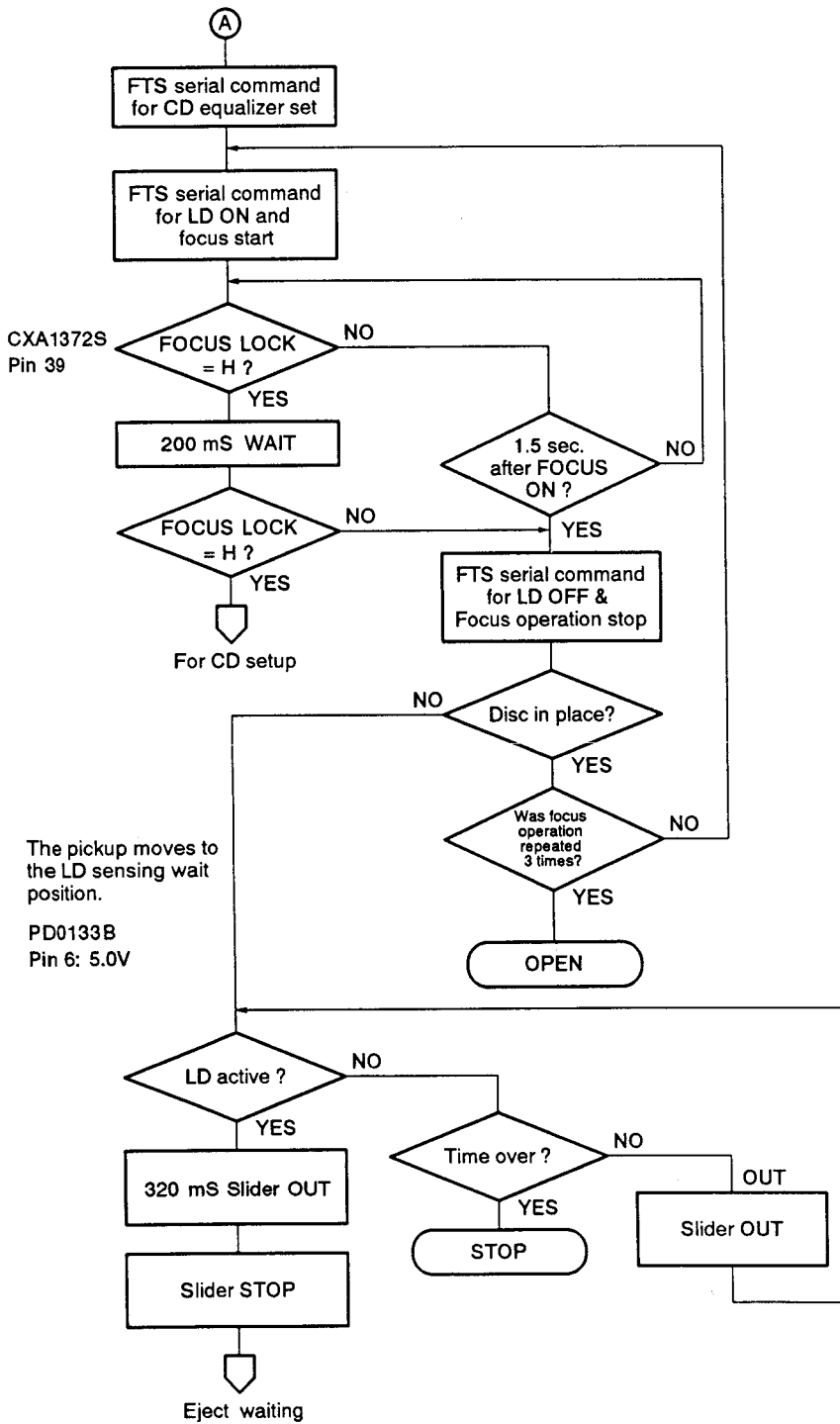

- Pickup position for CD focusing = R30
- CD focusing is the same as LD focusing.
- R:Distance from the center of the spindle motor.

- R65, the LD sensing position
- R:Distance from the center of the spindle motor.

- Timer for 10 seconds
- Timer indicates the time over.

Fig. 3-12

Flow of the LD Setup Operation

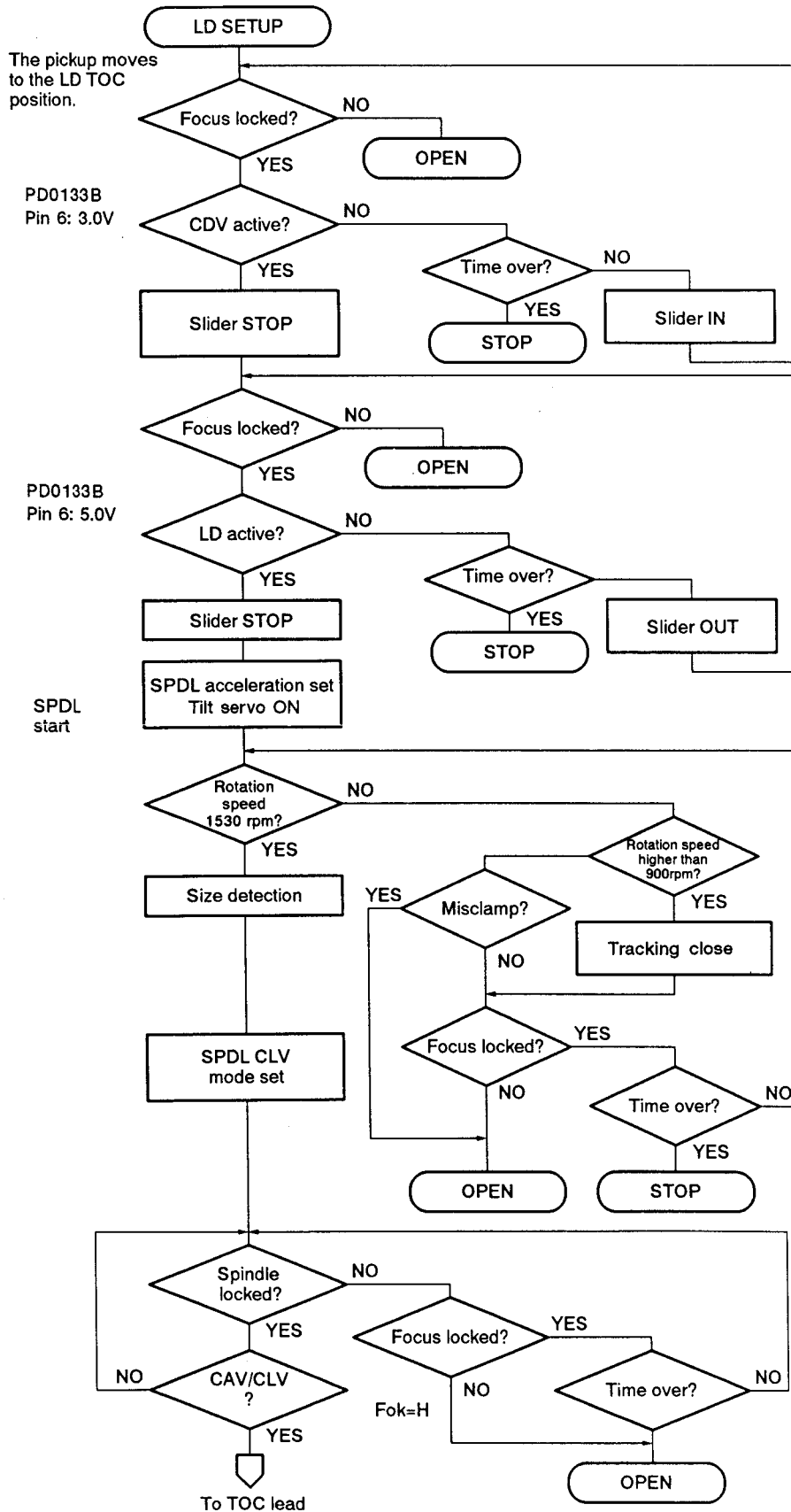

- If focus is lost while the pickup is moving to the spindle startup position, the tray opens, judging it to be CD and LD disc-stacking error.

- Timer for approx. 10 seconds
Timer indicates the time over.

- Timer for approx. 10 seconds.

- Tracking servo open mode is active until disc rotation exceeds 900 rpm.

- The disc rotation is forcibly accelerated until it reaches 1530 rpm, and the disc size is determined by the time required to reach 1200rpm.

- If 800 or more tracks are crossed in a single rotation of the disc, the tray opens, regarding it to be a misclamp.
- If focus is lost during the startup operation, the tray opens, assuming a damaged disc or the flip side of a single-sided disc.
- If the spindle is not locked within 60 seconds after beginning SPDL acceleration, the operation stops.

Fig. 3-13

Flow of the Frame Search Operation

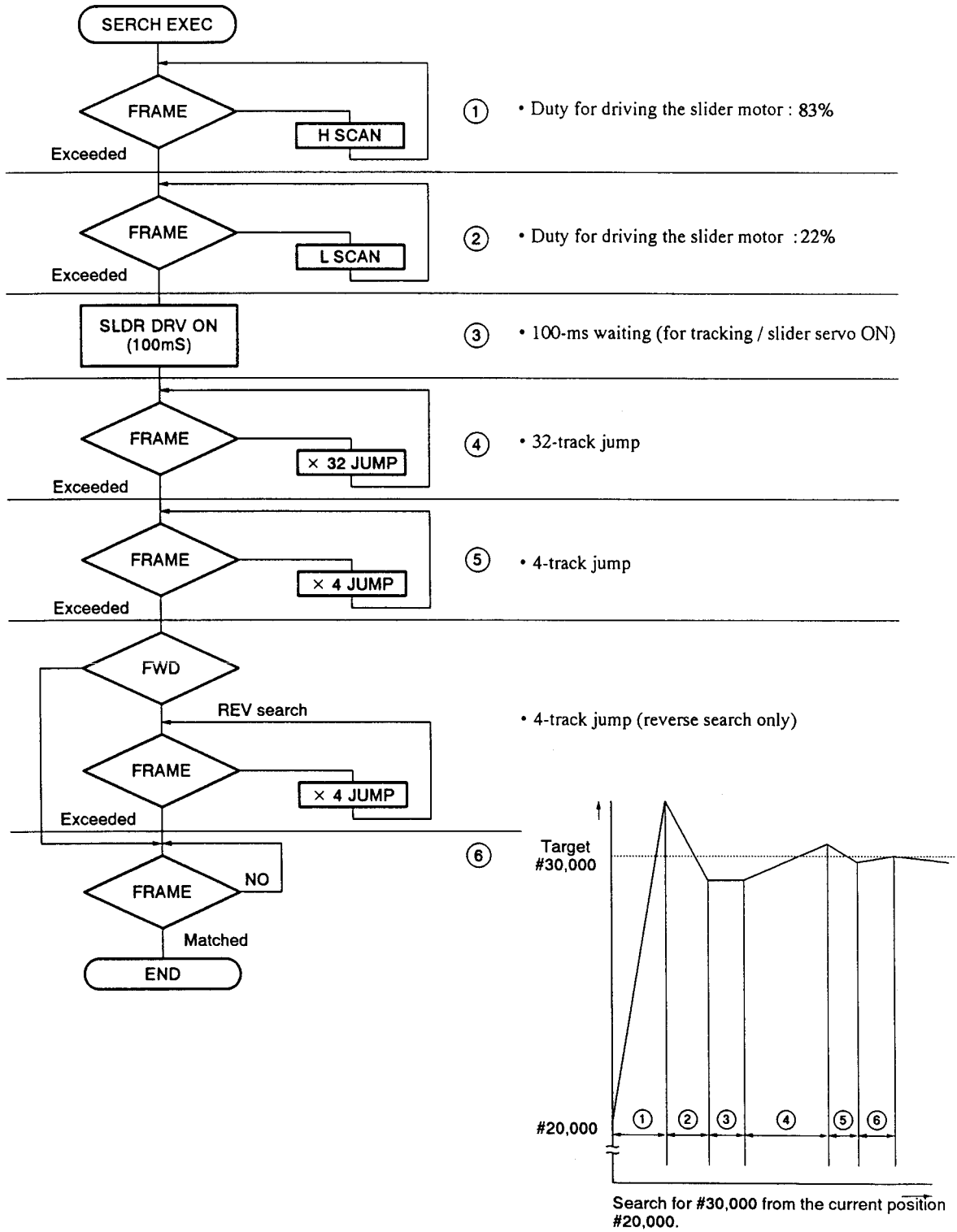

Fig. 3-14

● **Player Operation Modes**

MODE 1 – OPEN

Step	Operation
0	Clears internal registers, sets the spindle to STOP and waits for focus OFF.
1	↓
2	
3	
4	
5	
6	
7	
8	
9	Starts to move the slider to the LD sensing position.
A	Waits for the spindle to stop.
B	Waits for the slider to reach the LD sensing position.
C	Starts unloading.
D	Performs unloading until the OUT SW activates.
E	Sets the 100 ms timer.
F	Waits for 100 ms.
	Completed

MODE 3 – STOP

Step	Operation
0	Clears internal registers, sets the spindle to STOP and waits for focus OFF.
1	↓
2	
3	
4	
5	
6	
7	
8	
9	Starts to move the slider to the LD sensing position.
A	Waits for the spindle to stop.
B	Waits for the slider to reach the LD sensing position.
C	Starts to move the tilt to the neutral position.
D	↓
E	Waits for the tilt to reach the neutral position.
	Completed

MODE 2 – STANDBY

Step	Operation
0	Clears internal registers, sets the spindle to STOP and waits for focus OFF.
1	↓
2	
3	
4	
5	
6	
7	
8	
9	Starts to move the slider to the LD sensing position.
A	Waits for the spindle to stop.
B	Waits for the slider to reach the LD sensing position.
C	Starts to move the tilt to the neutral position.
D	Waits for the tilt to reach the neutral position.
	Completed

MODE 4 – DISC SENSING

Step	Operation			
0	Waits for the tilt to be neutral.			
	<table border="1"> <tr> <td>Normal</td> <td>CD direct mode</td> </tr> <tr> <td>LD sensing</td> <td>CD sensing</td> </tr> </table>	Normal	CD direct mode	LD sensing
Normal	CD direct mode			
LD sensing	CD sensing			
1	Starts to move the slider to the LD sensing position. Clears the focus-try counter.			
2	Waits until the slider reaches the LD sensing position.			
3	Tries focusing.			
	Focus unlocked	Focus locked		
	LD presence assured. Completed.			
4	Focus OFF			
5	Starts to move the slider to the CD sensing position.			
6	Waits until the slider reaches the CD sensing position.			
7	Tries focusing.			
	Focus unlocked	Focus locked		
	CD presence assured. Completed.			
8	Focus OFF			
9	Starts to move the slider to the LD sensing position. Clears the focus-try counter.			
A	Starts to move the slider to the LD sensing position.			
B	Checks for CD direct mode.			
	CD direct mode.	Normal		
C	Tries focusing.			
	Focus unlocked	Focus locked		
	LD presence assured. Completed.			
D	Focus OFF			
E	No disc assured. Completed.			

MODE 5 – SETUP

Step	Operation			
0	Waits for the tilt to be neutral. Sets the slider target position.			
	<table border="1"> <tr> <td>CD</td> <td>LD</td> </tr> <tr> <td>Starts to move the slider to the CD TOC position.</td> <td>Starts to move the slider to the LD TOC position.</td> </tr> </table>	CD	LD	Starts to move the slider to the CD TOC position.
CD	LD			
Starts to move the slider to the CD TOC position.	Starts to move the slider to the LD TOC position.			
1	Checks focus. Simultaneously checks for disc stacking (LD + CD)			
	Focus locked (OK)	Focus unlocked (NG)		
	Waits until the slider reaches the target position.	LD	CD	
		Ends with the focus error status.	Ends with the focus error after three unsuccessful tries.	
2	Sets the spindle.			
	CD set	CDV set	LD set	
Sets the 60-second timer. Starts to run the spindle.				
3	Checks focus.			
	Focus locked (OK)	Focus unlocked (NG)		
	Waits until the spindle locks while checking for misclamping.	Time over. Ends with the spindle error status.	Ends with the clamping error status.	
	Sets the 60-second timer.			
4	LD	CD, CDV		
	Distinguishes CAV / CLV.			
	Not distinguished	Distinguished		
5	Checks focus.			
	Focus locked (OK)	Focus unlocked (NG)		
	Waits the codes to be read.	Time over.	Ends with the focus error.	
	Slowly moves the slider to the inner or outer periphery until the PGM area code is read. After reading the code, sets the 60-second timer and returns to step 4.	Ends with the code error.		
6	Completed.			

MODE 6 – TOC READ

Step	Operation		
0	Diverges depending on the disc type.		
	LD		CD, CDV
1	Clears 1st address. Sets the 15-second timer.		
2	Moves to the lead-in area and checks the focus time.		
	A 24-bit code read.		Not read
	Lead-in area	PGM area, lead-out area	
	↓	32-track REV jump	Playback
3	Moves to the PGM area and checks the focus time.		
	A 24-bit code read.		Not read
	PGM area	Lead-in area	
	↓	18-track FWD jump	Playback
4	Moves to the lead-in area and checks the focus time.		
	A 24-bit code read.		Not read
	Lead-in area	PGM area	
	↓	4-track REV jump	Playback
5	Plays to the PGM area and checks the focus time.		
	A 24-bit code read.		Not read
	PGM area	Lead-in	
	↓	Sets the 0.5-second timer.	Playback
6	Stores the 1st address (CH, time) in memory and checks the focus time.		
	After 0.5 seconds, checks for CH and the seconds.		
	Sets the 0.5-second timer. ↓		
7	Checks for TOC (subcodes) and checks the focus time.		
	TOC available ↓	Ends with no TOC if no subcode can be read in 0.5 seconds.	
8	Sets the 15-second timer.		
9	Waits until TOC is read.		Time over. TOC reading completed
	PGM area	Lead-in area. Subcode NG.	Ends with the TOC error status.
	↓	Playback	
A	Subcode OK and focus check NG.		
	32-track REV jump	↓	Playback
B	Subcode OK and focus check NG		
	32-track REV jump	↓	Playback
C	Subcode OK and focus check NG		
	32-track REV jump	↓	Playback
D	Subcode OK and focus check NG		
	32-track REV jump	↓	Playback
E	Returns to step 9.		

MODE 8 – SEARCH

Step	Operation			
0	Focus ON		Focus OFF	
	Sets the 15-second timer.		Ends with the recovery error.	
	Diverges depending on the disc search target.			
	CDV		CD	LD
	Track search	(Absolute time wait)		
	A ↔ V	A ↔ V V ↔ A		
	↓			
1	Clears the focus-try counter and starts the spindle STOP operation. Starts to move the slider.			
	To A → V CDV TOC position.	To V → A CD TOC position.		
2	Waits until the slider reaches the specified position.			
	Waits for spindle STOP. → Ends with the disc stack (clamp) error if the spindle does not stop in 1.8 seconds.			
	Focus locked (Sets the 15-second timer.)	Tries focusing.		
	Sets the spindle for CD audio.	Sets the spindle for CDV video.	Ends with the recovery error after four unsuccessful tries.	
3	Waits until the spindle locks.			
	Waits until the subcode is read. ↓			
4	Sets the 10-time track counter.			
5	Drives the slider while counting tracks.			
	When the lag from the target address is more than 1 minute.	When the slider comes close to the target within about 1 minute.		
	Drives the slider.			
7	Drives the slider to cross the target address (H SCAN).			
8	Drives the slider to cross the target address (L SCAN). ↓			
9	Performs 32-track jumps to cross the target address.			
A	Performs 4-track jumps to cross the target address. Sets the 5-second timer.			
B	Performs 4-track jumps to reach the front of the target address.		Time check NG → Ends with the search error.	
	Plays until the target address is reached.			
C	Time out		Reached	
	LD, CDV - V	CD, CDV - A	LD, CDV - V	
	Ends with the search error.	Spindle locked	Unlocked	
		Completed	LD	CDV - V
		To step B	REV 1 jump	
D	Performs 4-track jumps to a point before the target address. Time check NG → Ends with the search error.			
E	Plays until the target address is reached.			
F	If another new search target is specified during search, waits the spindle to lock and returns to step 0.			

3.5 OUTLINE OF THE MODE CONTROL SYSTEM



1) Description of the Mode Microcomputer (IC201)

The mode microcomputer performs the following processing:

1. Key data/remote control signal processing
Accepts the key switch and remote control signals and processes them for the specified keys.
2. FL (fluorescent) display operation
Operates the FL tube (VAW1026) display.

3. Screen-display control
Controls the character generator IC (IC405: PD0093A) and superimposes characters on the screen.
The blue-background screen is also controlled.
4. Mechanism-control IC control
Gives operational instructions to the mechanism control microcomputer (IC101: PD0133B) and simultaneously reads the time data, etc.
5. System reset management
If any problem occurs in communication with the mechanism-control IC, activates system reset to return the IC to its initial state.

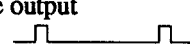
• Description of the Mode microcomputer (IC201: PD3213A)

Pin	Pin name	Signal name	I/O	Function
01	P04/AN4	NC	I	Not used
02	P05/AN5	NC	I	Not used
03	P06/AN6	NC	I	Not used
04	P07/AN7	NC	I	Not used
05	AVss	AVss	-	Connected to standard power supply (Vss) for A/D conversion
06	TEST	TEST	I	Test pin Connected to Vss
07	X2	X2	O	Subclock Release
08	X1	X1	I	Subclock Connected to Vcc
09	Vss	Vss	-	Ground
10	OSC1	OSC1	I	System clock Connects 8 MHz ceramic lock
11	OSC2	OSC2	O	System clock Connects 8 MHz ceramic lock
12	$\overline{\text{RESET}}$	$\overline{\text{RESET}}$	I	Reset
13	P10/IRQ0	SHAKE	I/O	Communication timing clock with mechanism control
14	P11/ $\overline{\text{IRP1}}$	SEL IR	I	Remote control signal (including SR)
15	P12/ $\overline{\text{IRQ2}}$	W.D.F	O	For watchdog timer Pulse output 
16	P13/ $\overline{\text{IRQ3}}$	POWER On	O	Power ON  Power OFF
17	P14/IRQ4	NC	O	Not used
18	P15/ $\overline{\text{IRQ5}}$	NC	O	Not used
19	P16/EVENT	NC	I	Not used
20	P33/FS27	NC	O	Not used

Pin	Pin name	Signal name	I/O	Function
21	P32/FS26	NC	O	Not used
22	P31/FS25	NC	O	Not used
23	P30/FS24	STANBY LED	O	Standby LED drive output
24	P47/FS23	NC	O	Not used
25	P46/FS22	NC	O	Not used
26	P45/FS21	NC	O	Not used
27	P44/FS20	NC	O	Not used
28	P43/FS19	seg l / KS3	O	FL segment l output and key scan 3 output
29	P42/FS18	seg k / KS2	O	FL segment k output and key scan 2 output
30	P41/FS17	seg j / KS1	O	FL segment j output and key scan 1 output
31	P40/FS16	seg i / KS0	O	FL segment i output and key scan 0 output
32	P50/FS15	seg h	O	FL segment h output
33	P51/FS14	seg g	O	FL segment g output
34	P52/FS13	seg f	O	FL segment f output
35	P53/FS12	seg e	O	FL segment e output
36	P54/FS11	seg d	O	FL segment d output
37	P55/FS10	seg c	O	FL segment c output
38	P56/FS9	seg b	O	FL segment b output
39	P57/FS8	seg a	O	FL segment a output
40	P17/Vdisp	-30V	-	FL drive power supply
41	P60/FD0/FS7	G9	O	FL grid 9 output
42	P61/FD1/FS6	G8	O	FL grid 8 output
43	P62/FD2/FS5	G7	O	FL grid 7 output
44	P63/FD3/FS4	G6	O	FL grid 6 output
45	P64/FD4/FS3	G5	O	FL grid 5 output
46	P65/FD5/FS2	G4	O	FL grid 4 output
47	P66/FD6/FS1	G3	O	FL grid 3 output
48	P67/FD7/FS0	G2	O	FL grid 2 output
49	P70/FD8	G1	O	FL grid 1 output
50	P71/FD9	NC	O	Not used
51	P72/FD10	NC	O	Not used
52	P73/FD11	NC	O	Not used
53	P74/FD12	NC	O	Not used
54	P75/FD13	D.CD LED	O	DIRECT CD LED drive output
55	P76/FD14	S-SCAN	I/O	SHUTTER SCAN output
56	P77/FS15	NC	O	Not used
57	Vcc	Vcc	-	Power supply

Pin	Pin name	Signal name	I/O	Function
58	P80	KIN0	I	Key input 0
59	P81	KIN1	I	Key input 1
60	P82	KIN2	I	Key input 2
61	P83	KIN3	I	Key input 3
62	P84	KIN4	I	Key input 4
63	P85	KIN5	I	Key input 5
64	P86	KIN6	I	Key input 6
65	P87	NC	–	Not used
66	P90/PWM	SYNCHRO OUT	O	SYNCHRO REC output
67	P91/SCK1	XSCK	I/O	Communication clock with mechanism control/OSD
68	P92/SI1	SI	I	Receive data from mechanism control
69	P93/SO1	SO	O	Send data to mechanism control/OSD
70	P94/SCK2	XRESET	O	RESET output from other than mechanism control/OSD
71	P95/SI2/CS	XCS	O	OSD chip select
72	P96/SO2	SYNCHRO IN	I	SYNCHRO REC input
73	P97/UD	NC	O	Not used
74	PA0	NC	O	Not used
75	PA1	NC	O	Not used
76	AVcc	AVcc	–	Connection to Vcc of standard power supply for A/D conversion
77	P00/AN0	NC	I	Not used
78	P01/AN1	NC	I	Not used
79	P02/AN2	NC	I	Not used
80	P03/AN3	NC	I	Not used

2) Hilite Scan

The middle (regarded as the hilite or climax) of each recording on a disc is played back for about 8 seconds.

During a hilite scan operation, the Hilite/intro FL indication lights, and the Hilite indication appears on the screen.

When the Hilite/Intro key on the player is pressed, the following operations are performed depending on the player's status.

1. When the key is pressed during disc playback, the time (e.g. 1 min. 30 sec.) from the beginning of the recording when the key is pressed is stored in memory and 8 seconds from that specified time (e.g. 1 min. 30 sec. to 1 min. 38 sec.) for all the recordings from track 1 to the end are played back.
2. When the key is pressed in stop, tray-open or search modes, the parts from 1 min. 00 sec. to 1 min. 08 sec. of all the recordings on the disc are played back.
3. When the key is pressed during CDV video portion playback, an introduction scan is executed for the video portion, and the highlight scan is performed for the audio portion as in 2 above.
4. When the key is pressed during playback of the audio portion of a CDV, an introduction scan is executed for the video portion, and the highlight scan is performed for the audio portion as in 1 above.

This function is enabled only for CDs and the audio portions of CDV discs. For LDs and the video portions of CDV discs, introduction scanning is performed.