

Service Manual

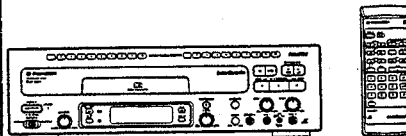

ORDER NO.
RRV1160

The chapter 1 of this Service Manual will not be reprinted. On your additional orders, we may supply only the chapter 2. For the chapter 1, please make copies and attach to the chapter 2 at your side if necessary.

CD CDV LD PLAYER

CLD-160K

THIS MANUAL IS APPLICABLE TO THE FOLLOWING MODEL(S) AND TYPE(S).

Type	Model	Power Requirement	The voltage can be converted by the following method.
	CLD-160K		
HB	○	AC240V	AC220—230V, *
HEZ	○	AC220—230V	AC240V, *

* : Alter the wiring of the Power-supply block at the primary winding of Power-transformer referring to the "Line Voltage Selection" described in Service Manual.

CONTENTS

CHAPTER 1

1.1 SAFETY INFORMATION	1-2
1.2 SPECIFICATIONS	1-3
1.3 PANEL FACILITIES.....	1-4
1.4 IC INFORMATION	1-6
1.5 FL INFORMATION	1-9
1.6 ADJUSTMENTS.....	1-10
1.7 PARTS LIST FOR PACKING AND EXPLODED VIEWS	1-23
1.8 PCB PARTS LIST	1-27

CHAPTER 2

2.1 PACKING AND EXPLODED VIEWS ...	2-3
2.2 SCHEMATIC AND PCB CONNECTION DIAGRAMS.....	2-12

CHAPTER 1

1.1 SAFETY INFORMATION

(FOR EUROPEAN MODEL ONLY)

VARO!
AVATTAESSA JA SUOJALUKITUS OHITETTAESSA OLET ALTTIINA NÄKYMÄTTÖMÄLLE LASERSÄTEILYLLE. ÄLÄ KATSO SÄTEESEEN.



LASER
Kuva 1
Lasersäteilyn varoitusmerkki

WARNING!
DEVICE INCLUDES LASER DIODE WHICH EMITS INVISIBLE INFRARED RADIATION WHICH IS DANGEROUS TO EYES. THERE IS A WARNING SIGN ACCORDING TO PICTURE 1 INSIDE THE DEVICE CLOSE TO THE LASER DIODE.



LASER
Picture 1
Warning sign for laser radiation

ADVERSEL:
USYNLIG LASERSTRÅLING VED ÅBNING NÅR SIKKERHEDSAFBRYDERE ER UDE AF FUNKTION UNDGÅ UDSÆTTELSE FOR STRÅLING.

VARNING!
OSYNLIG LASERSTRÅLNING NÅR DENNA DEL ÄR ÖPPNAD OCH SPÄRREN ÄR URKOPPLAD. BETRakta EJ STRÅLEN.

IMPORTANT
THIS PIONEER APPARATUS CONTAINS LASER OF CLASS 1. SERVICING OPERATION OF THE APPARATUS SHOULD BE DONE BY A SPECIALLY INSTRUCTED PERSON.

LASER DIODE CHARACTERISTICS
MAXIMUM OUTPUT POWER: 5 mw
WAVELENGTH: 780-785 nm

LABEL CHECK

HB model

CAUTION
INVISIBLE LASER RADIATION WHEN OPEN, AVOID EXPOSURE TO BEAM
PRW1018

HEZ model

VARO!
Avattaessa ja suojalukitus ohitettaessa olet alttiina näkymättömälle lasersäteilylle. Älä katso säteeseen.
VARNING!
Osynlig laserstråling när denna del är öppnad och spärren är urkopplad. Betrakta ej strålen.
VRW1297.4

HEZ and HB models

CLASS 1 LASER PRODUCT
VRW-328

HEZ model

ADVARSEL
USYNLIG LASERSTRÅLING VED ÅBNING NÅR SIKKERHEDSAFBRYDERE ER UDE AF FUNKTION. UNDGÅ UDSÆTTELSE FOR STRÅLING.
VORSICHT!
UNSICHTBARE LASERSTRÅHLUNG TRITTT AUS, WENN DECKEL (ODER KLAPPE) GEÖFFNET IST! NICHT DEM STRAHL AUSSETZEN!
VRW1094



HEZ and HB models

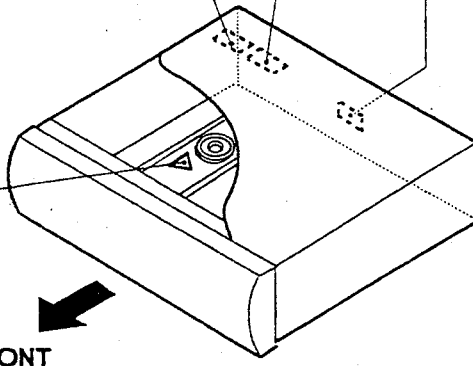

Additional Laser Caution

- The ON/OFF statuses of the slider - position detection switches (PARK INNER, PARK OUTER on the PASB assembly), loading - status detection switches (SW 1,2 and 3 on LOSB assembly) are detected by the microprocessor (IC101 in the MAIN ASSY). To permit the laser diode to oscillate, it is required to set the slider - position detection switch for the LD ACTIVE status (PARK INNER: OFF, PARK OUTER: OFF), and to set the loading - status detection switch for tilt neutral state (SW1: ON, SW2: OFF, SW3: ON). As long as these requirements are not satisfied, the laser diode will not oscillate. When the requirements are met in any way, the laser diode can oscillate. The laser diode oscillation will continue if pin 13 of IC801 is shorted to GND or the emitter and collector of Q834 are shorted each other (fault condition) in MAIN ASSY.
In the test mode*, the laser diode oscillates when microprocessor detects a PLAY signal, or when the PLAY key is pressed (S207 ON in the FLKY assembly), with the above requirements satisfied.
- When the cover is open, close viewing through the objective lens with the naked eye will cause exposure to a Class 1 laser beam.

* Refer to page 1-10.

1.2 SPECIFICATIONS

General

System	LaserVision Disc system and Compact Disc digital audio system
Laser	Semiconductor laser wavelength 780 nm
Power requirements	
European model	AC 220 - 230 V, 50/60 Hz
U.K. model	AC 240 V, 50/60 Hz
Power consumption	43 W
Weight	
European model	7.5 kg
U.K. model	7.6 kg
Dimensions	420 (W) x 385 (D) x 122 (H) mm
Operating temperature	+5 °C ~ +35 °C
Operating humidity	5 % ~ 85 %
(There should be no condensation of moisture.)	

Video characteristics

Format	NTSC/PAL specifications
Video output	
Level	1 Vp-p nominal, sync. negative, terminated
Impedance	75 Ω unbalanced
Jack	RCA jack

Audio characteristics

Output level	200 mVrms
During analog audio output	(1 kHz, 40 %)
During digital audio output	200 mVrms
(1 kHz, -20 dB)	
Jacks	Both RCA jacks
Number of channels	2 (Stereo)

Other terminals

Control input/output	Both miniature jacks
AUX	RCA jacks
Microphone input	2
MIC control input	miniature jack
Headphone input	1
AV connector output	21-pin connector

This connector provides the video and audio signals for connection to a colour video TV monitor (or TV set) which has a "AV CONNECTOR" terminal.

21-pin connector assignment

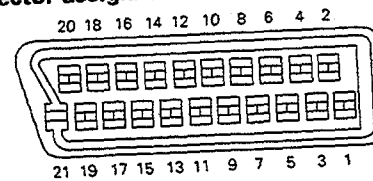

PIN no.	1 Audio 2/R out	17 GND
	3 Audio 1/L out	19 Video out
	4 GND	21 GND
	8 Status	

Accessories

Remote control unit	1
Size "AAA" (IEC R03) dry cell batteries	2
Audio cord	1
Video cord	1
Operating instructions	1
Warranty card	1

NOTE:

The specifications and design of this product are subject to change without notice, due to improvement.

1.3 PANEL FACILITIES

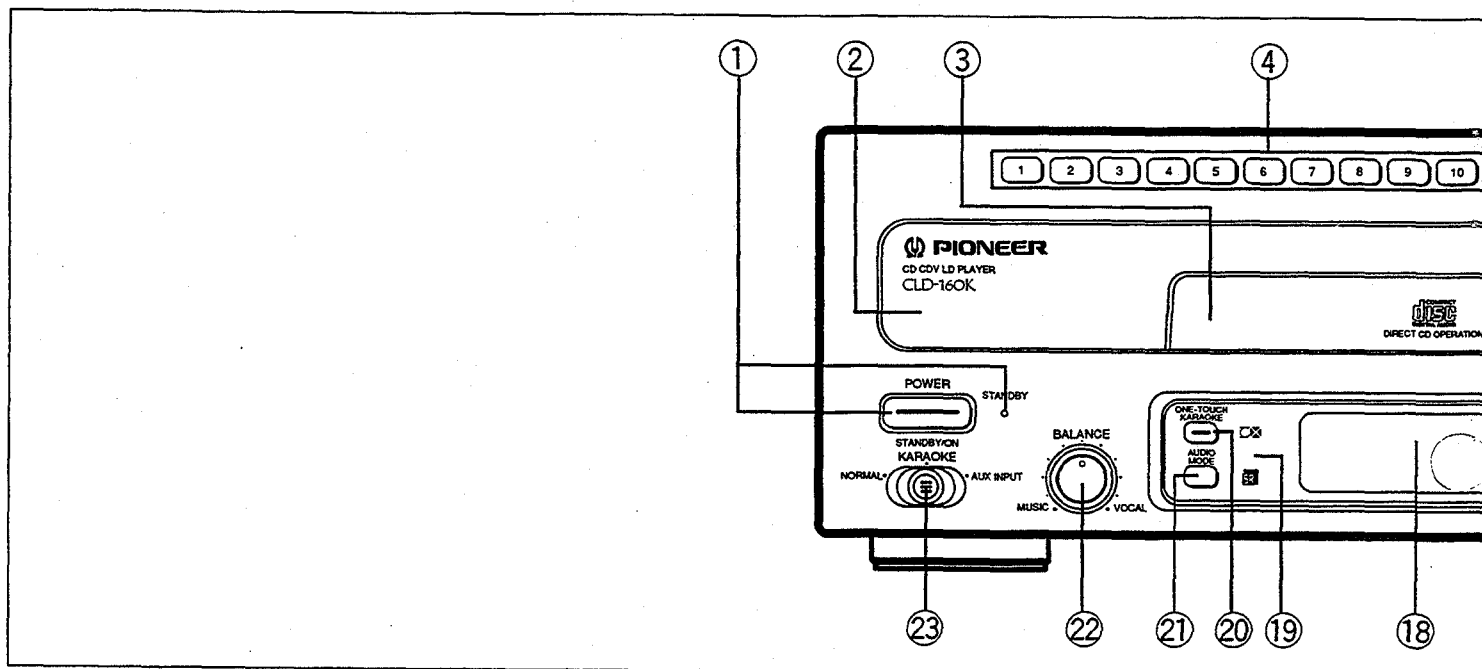

- | | |
|--|---|
| <ul style="list-style-type: none"> ① POWER/STANDBY/ON switch and STANDBY indicator
Press to turn the power on and off. ② Disc table ③ CD Disc table ④ DIRECT MUSIC SEARCH buttons ⑤ Stop (■) button ⑥ Play/Pause (▶/⏸) button ⑦ OPEN/CLOSE (CD ▲/LD ▲) buttons ⑧ KEY CONTROL buttons ⑨ MIC 1 jack and MIC 1 level control ⑩ MIC 2 jack and MIC 2 level control ⑪ MIC CONTROL jack | <ul style="list-style-type: none"> ⑫ PHONES jack and LEVEL control ⑬ SCORING button/indicator ⑭ ECHO level control ⑮ SURROUND button/indicator ⑯ SYSTEM button ⑰ 16:9 button ⑱ Display window ⑲ Remote sensor ⑳ ONE-TOUCH KARAOKE button/indicator ㉑ AUDIO MODE button ㉒ BALANCE control ㉓ NORMAL/KARAOKE/AUX INPUT selector |
|--|---|

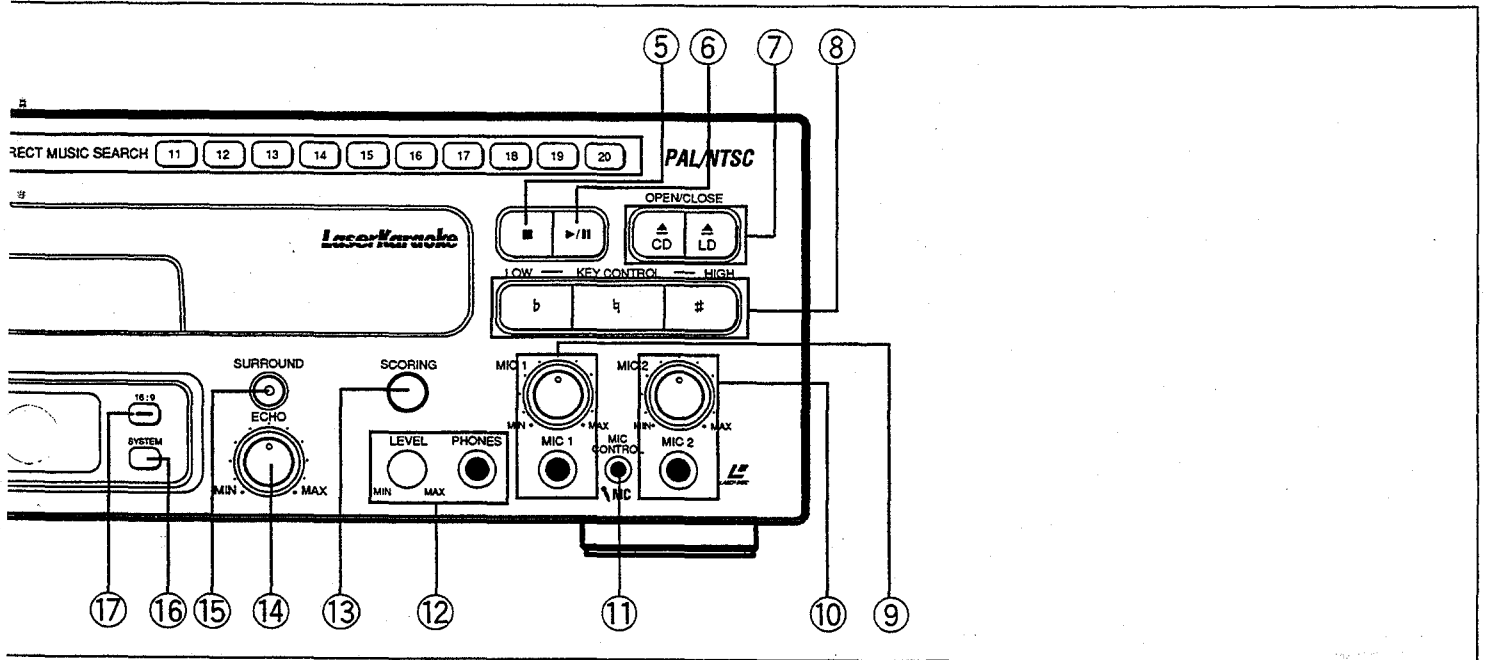

1.4 IC INFORMATION

■ PD3286B (FLKB ASSY IC101)

● Mode control IC

● Pin function

No.	Symbol	Pin name	I/O	Function
1	AN4	xREQ	I	Request for DSP L: Request
2	AN5	MICSENS	I	Microphone detection H: Installed L: Not installed
3	AN6	MODESW	I	Audio mode (A/D) Karaoke/Normal/AUX input
4	AN7	Not Used	I	GND
5	AVSS	Not Used	I	
6	TEST	Not Used	I	
7	X2	---	O	Not connected (Open)
8	X1	---	I	GND
9	VSS	GND	I	
10	OSC1	---	I	Main system clock oscillation (8 MHz)
11	OSC2	---	O	
12	xRST	RESET	I	CPU Reset (L: Reset)
13	IRQ0	SHAKE	I	Mechanism controller serial communication request
14	IRQ1	SEL IR	I	Remote control input
15	P12	DOGFOOD	O	Pulse output for watchdog timer
16	P13	POWERON	O	Switching output for mother board power supply
17	P14	THRU	O	Through output for DSP H: Through L: DSP ON
18	P15	EXTXINT	O	External/Internal H: External L: Internal
19	P16	XPOWKEY	I	Power-key input L: Key ON H: OFF
20	P33	Not Used	I	GND
21	P32	Not Used	I	
22	P31	Not Used	I	
23	P30	Not Used	O	Not connected (Open)
24	P47	xMICON	O	Microphone input ON/OFF H: Disable microphone input L: Enable
25	P46	LEDWKV	O	LED for the VOCAL PARTNER
26	P45	LEDONT	O	LED for the one-touch karaoke
27	P44	STDBYL	O	LED for standby
28	P43	Not Used	O	Not connected (Open)
29	P42	SEG k	O	
30	P41	SEG j	O	
31	P40	SEG i	O	
32	P50	KSCAN0/SEG h	O	Key scan output/ Display segment output
33	P51	KSCAN1/SEG g	O	
34	P52	KSCAN2/SEG f	O	
35	P53	KSCAN3/SEG e	O	
36	P54	KSCAN4/SEG d	O	
37	P55	KSCAN5/SEG c	O	
38	P56	SEG b	O	
39	P57	SEG a	O	
40	VDISP	---	I	-27V (FL bias)

● The information shown in the list is basic information and may not correspond exactly to that shown in the schematic diagrams.

No.	Symbol	Pin name	I/O	Function
41	P60	G1	O	Display grid output
42	P61	G2	O	
43	P62	G3	O	
44	P63	G4	O	
45	P64	G5	O	
46	P65	G6	O	
47	P66	G7	O	
48	P67	G8	O	
49	P70	G9	O	
50	P71	G10	O	
51	P72	LEDSCR	O	LED output for the scoring mode
52	P73	LEDSRD	O	LED output for the DSP surround
53	P74	LEDWID	O	LED output for the 16:9 H: 16:9
54	P75	LEDLDO	O	LED output for the CD tray control
55	P76	LEDCDO	O	LED output for the LD tray control
56	P77	Not Used	O	Not connected (Open)
57	VCC	---	I	+5V
58	P80	KIN0	I	Key data input
59	P81	KIN1	I	
60	P82	KIN2	I	
61	P83	KIN3	I	
62	P84	KIN4	I	
63	P85	KIN5	I	Not connected (Open)
64	P86	Not Used	I	
65	P87	Not Used	I	
66	P90	Not Used	I	
67	xSCK1	XSCK	I/O	Serial communication clock for the mechanism controller and the character generator DSP.
68	SI1	S-MTOF	I	Serial communication data input from the mechanism controller
69	SO1	S-FTOM	O	Serial communication data output for the mechanism controller and the character generator DSP.
70	P94	XRESET	O	Reset output for the mother board
71	P95	XCSOSD	O	Chip select of the character generator DSP L: Active
72	P96	Not Used	O	Not connected (Open)
73	P97	Not Used	I	
74	PA0	XCSDSP	O	Chip select of DSP L: Active
75	PA1	A/D	O	For DSP H: Address L: Data
76	AVCC	---	I	+5V
77	AN0	ECHVOL	I	Echo volume (A/D)
78	AN1	MPXBAL	I	Multiplex onta balance (A/D)
79	AN2	MICSW	I	Microphone status input (A/D)
80	AN3	XD_RDY	I	READY input for DSP H: Busy L: Ready

■ PD0193A (MAIN ASSY IC101)

● Mechanism control IC

● Pin function

No.	Pin name	I/O	Function
1	VCC	I	Power connection pin. Impresses 5V ±10%.
2	XCD	O	LD/CD switching signal output pin. "L" = CD "H" = LD
3	RFCORR	O	RF collection switch signal output pin. "H" = gain up CD, CDV-A: Low Raise the gain with the CAV inner circuit, otherwise High.
4	GPWM	O	Duty pulse signal output terminal for spindle gain switching. CLV inner circuit : L Outer circuit : H
5	FBAL	O	Focus balance control H: TEMAX L: RFMAX
6	SLDERR	I A/D	Carries out A/D conversion of this signal and controlled input of the slider servo. Control the slider motor so that this signal becomes 2.5V.
7	SLDPOS	I A/D	Pick up position detection switch input pin. Divides the resistance of each switch and detects the reading position of the A/D input value.
8	TBALERR	I A/D	Tracking balance error signal input pin. Carries out A/D conversion of this signal and controlled input of the tracking offset.
9	TILTERR	I A/D	Carries out A/D conversion of this signal and controlled input of the tilt servo. Control the tilt motor so that this signal becomes 2.5V.
10	XFOK	I	Focus servo lock signal input pin. "L" = lock "H" = unlock Used for detecting focus servo locking.
11	FSEQ	I	Sub-code sync conformity detection signal input pin. "L" = Others "H" = Conformity
12	TBALDRV	O PWM	Carries out PWM output of the tracking offset, and is used for auto tracking offset. 910µsec cycles, 3 value control H, L, Z.
13	TLATCH	O	DAC & digital filter PD2026 serial control latch signal output terminal. Startup is latched.
14	TILTDRV	I/O	Load/tilt control output pin. 0, 5V - tray IN, OUT/tilt DOWN, UP 2.5V - STOP Carries out PWM output of the tilt drive, and is used for the tilt servo.
15	SQOUT	I	DSP reading command data input pin. SUBQ is read out.
16	COIN	O	DSP writing command data output pin.
17	CQCK	O	DSP reading/writing command clock output pin. Start-up reading.
18	SLD DRV	O PWM	Slider control signal output pin. 5V = FWD, 0V = REV, 2.5V = STOP 910µsec cycles, 3 value control H, L, Z.
19	SII	I	Input pin for data from mode control IC.
20	SOI	O	Serial data output to mode control IC.
21	SCK1	I/O	Clock for serial communication with mode control IC. Is set to input mode at all times when not used for communication with the mode control IC.
22	TZC	I INT	Tracking error zero cross signal input pin. At the time of miss clamp detection, this signal is monitored during track count search.
23	WRQ	I	Sub-code Q reading OK signal input pin. "L" = NG "H" = OK This terminal becomes H when the sub-code Q data passes the CRC check.
24	RWC	O	DSP reading/writing command signal output pin. "L" = READ "H" = WRITE
25	SHAKE	I/O	Handshake signal pin for data communication with mode control IC. This terminal is used as a data line for both directions, and each microcomputer carries out input/output control.
26	XPBV	I	LD/CDV play vertical synchronous signal input pin. "L" = vertical synchronous
27	CNVSS	I	GND grounding for A/D conversion.
28	XRESET	I	Reset signal input pin. "L" = reset "H" = reset cancel Controlled by mode control IC.
29	XIN	I	9MHz clock oscillation input pin.
30	XOUT	O	9MHz clock oscillation output pin.
31	N. C.	O	Not used. Since it is for only φ output, it cannot be used for anything else.
32	GND	I	GND grounding.
33	SWI	I	Switch input pin for loading/tilt position detection.

No.	Pin name	I/O	Function
34	SW2	I	Switch input pin for loading/tilt position detection.
35	SW3	I	Switch input pin for loading/tilt position detection.
36	XSLOCK	I	Spindle lock signal input pin. "H" = unlock "L" = lock
37	FG	I	Spindle motor FG signal input pin 24 outputs per rotation. Used after dividing by 3 in microcomputer.
38	DATA	I	Input pin for Phillips code decoder with built in mechanism controller.
39	PBH	I	Play H - SYNC input for Phillips code decoder.
40	XPBV	I	Play V - SYNC input for Phillips code decoder.
41	16:9	O	16:9 switching signal output pin. 16:9 "H" 4:3 (normal) "L"
42	VLOCK	I	Vertical synchronous lock detection signal input pin. "L" = phase is not correct "H" = phase is correct.
43	N. C.	O	Not used
44	N. C.	O	Not used
45	XPAL	O	PAL/NTSC signal output pin. L : PAL, H : NTSC
46	XPLAY	O	PLAY signal output terminal for PAL. L : PLAY H : NOT PLAY
47	JF/R	I/O	JUMP FWD signal output terminal for PAL. FWD jump : H REV jump : L Others : Z
48	SCK3	O	Serial 3 clock signal output pin.
49	XLATCH3	O	Serial 3 latch signal output pin TBC.
50	SO3	O	Serial 3 data signal output pin. The serial signal is a common one, and the signals are distinguished with latch signals (XLAT3, TLAT).
51	DIRECT	O	CD direct video line power off signal output pin. Video PWOFF: H normal: L
52	XCLV	O	CAV/CLV switching signal output pin. "H" = CAV, "L" = CLV
53	VSQ	O	Switching signal output terminal for the video signal. H : squelch ON L : squelch OFF
54	SENA	O	Shift enable signal output terminal. H : H is picked and REFV is made closer to PBV. L : Normal
55	CLRSCN	O	Clear scan signal output terminal. H : During clear scanning. L : Others
56	T HOLD	I	Track jump accelerating/decelerating signal input pin. "H" = accelerating/decelerating "L" = Others
57	HQON	O	High quality circuit control signal output terminal. H : HQ circuit ON. L : HQ circuit OFF.
58	AMPDET	I	Spindle overcurrent detection signal input pin. "L" = overcurrent "H" = normal
59	SQ1	O	Analog sound switching signal output pin. 1/L "L" = squelch OFF "H" = squelch ON
60	SQ2	O	Analog sound switching signal output pin. 2/R "L" = squelch OFF "H" = squelch ON
61	XCX	O	Analog sound CX noise reduction switching signal output pin. "L" = CX ON "H" = CX OFF
62	MUTE	O	Audio line sound mute control signal output pin. "H" = MUTE "L" = MUTE CANCEL
63	ACCONT	I/O	Output terminal for signal increasing/reducing the spindle speed. H : Accelerator L : Brake Z : Others
64	XANA	O	Digital/analog audio switch signal output pin. "H" = digital "L" = analog

1.5 FL INFORMATION

● VAW1034 (FLKB ASSY : V101)

ANODE GRID ASSIGNMENT

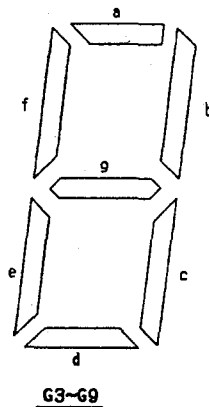
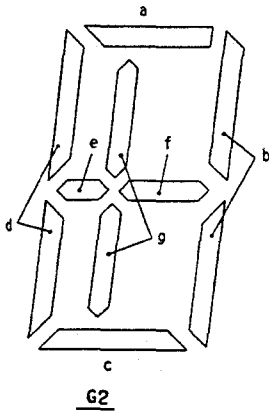
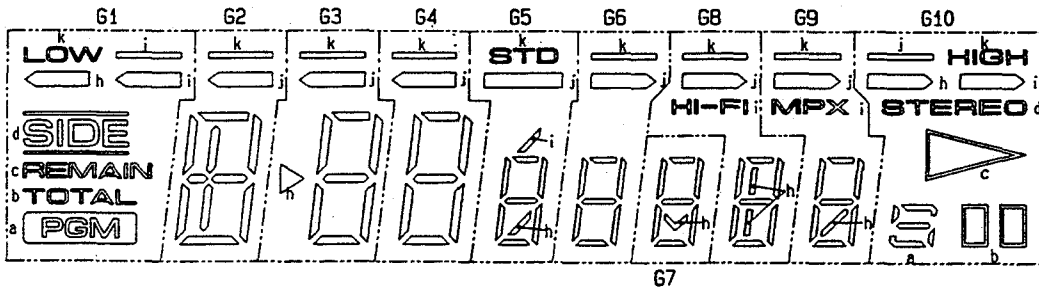

	G1	G2	G3	G4	G5	G6	G7	G8	G9	G10
P1	PGM	a	a	a	a	a	a	a	a	S
P2	TOTAL	b	b	b	b	b	b	b	b	□□
P3	REMAIN	c	c	c	c	c	c	c	c	△
P4	SIDE	d	d	d	d	d	d	d	d	STEREO
P5	/	e	e	e	e	e	e	e	e	/
P6	/	f	f	f	f	f	f	f	f	/
P7	/	g	g	g	g	g	g	g	g	/
P8	← (L)	/	▷	/	/ (Lower)	/	∨	!	/	← (L)
P9	← (R)	/	/	/	/ (Upper)	/	/	HI-FI	MPX	← (R)
P10	—	←	←	←	—	←	/	—	—	—
P11	LOW	—	—	—	STD	—	/	—	—	HIGH

PIN ASSIGNMENT

Pin No.	1	2	3	4	5	6	7	8	9	10	11	12	13	14	15	16	17
Assignment	F	F	NP	NL	NL	NL	NL	P11	P10	P9	P8	P7	P6	P5	P4	P3	P2
Pin No.	18	19	20	21	22	23	24	25	26	27	28	29	30	31	32	33	34
Assignment	P1	NL	G1	G2	G3	G4	G5	G6	G7	G8	G9	G10	NL	NL	NP	F	F

F:Filament G1-G10:Grid P1-P11:Anode NP:No pin NL:No lead

1.6 ADJUSTMENTS

1.6.1 TEST MODE

1) How to start test mode

With the MAIN ASSY test mode TP (W407) dropped to GND, the test mode is started by putting the power switch ON. (Fig. 1)

After confirming that all FL indicators are lit, remove test mode jumper wire and GND connection. Or, with power switch ON, press test mode remote control (GGF1067) ESC key and TEST key in order.

- When entering the test mode, the FL display and the LED will light until an operation is carried out with a key.
- When entering the test mode, the TV system will become that of NTSC.
- During the test mode, the background will be blue if an LD or a CDV is not playing (When NTSC and PAL), or black (in the case of quasi-PAL).
- The TV system is unconditionally toggled between the 3 systems of PAL → NTSC → quasi-PAL.

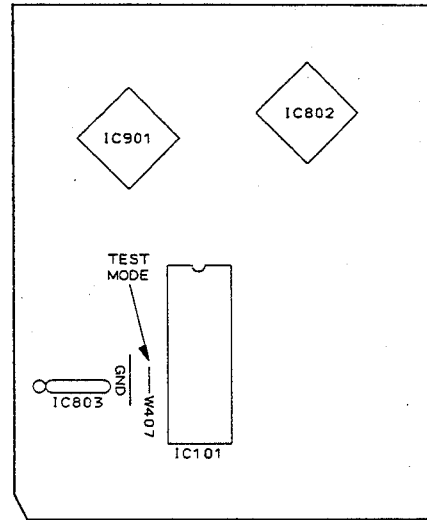

MAIN ASSY

Fig. 1

2) How to cancel test mode

Turn power switch OFF. Or, press test mode remote control ESC key.

3) Functions and key control when in test mode

Note: For keys not on player or on accompanying remote control, use test mode remote control (GGF1067)

• Key operation in the Test mode

Player Status	Key Operation	Function	Remarks
Tray Open	⏪/⏩ SKIP (Refer to Note 1)	⏪: Shifts the tray in the closed direction and also raises the turn table while pressing the key. ⏩: Shifts the tray in the open direction and also lowers the turn table while pressing the key.	
Tray Open	▶ PLAY	Clamps	
Clamp	▶ PLAY	Turns the disc through TRK Servo OFF	TRK-OFF
TRK Servo OFF	▶ PLAY	TRK Servo ON	TRK-ON
TRK Servo ON	▶ PLAY	TRK Servo OFF	TRK-OFF
TRK Servo ON	◀ / ▶ (STEP)	FOCS balance select	F-0/F-1
TILT Neutral	+ MULTI-SPEED	TILT Servo ON	T-□: ON
TILT ON	-MULTI-SPEED	TILT Neutral	T-□: N
TILT Neutral or ON	⏪/⏩ SKIP	Setting TILT Servo to OFF, can force TILT to move.	T-1 to T-E
Clamp	⏪/⏩ SCAN	Can force the slider to move	S-LD S-CDV S-CD S-IN
Play	PAUSE	Still	
Play	■ STOP	Stop	
Stop	▲ OPEN	Open	
Play	<div style="display: flex; flex-direction: column; align-items: center;"> <div style="border: 1px solid black; padding: 2px;">+10</div> <div style="margin: 2px;">↓</div> <div style="display: flex; gap: 10px;"> <div style="border: 1px solid black; padding: 2px;">0</div> <div style="margin: 0 5px;">to</div> <div style="border: 1px solid black; padding: 2px;">9</div> </div> <div style="margin: 2px;">↓</div> <div style="border: 1px solid black; padding: 2px;">▶ PLAY</div> </div>	Sets to SEARCH Lead Address Input mode. Designates the SEARCH lead address through keys 0 to 9. Press the CLEAR [C] key if the designated address is incorrect. Searches the designated address upon pressing the PLAY key.	

Note 1: Press SKIP (⏪/⏩) Keys after the tray is set to open state by pressing Open (▲) key. Because, in tray open state, pressing PLAY (▶) key causes it to set to clamp state and SKIP (⏪/⏩) keys can not function properly.

Table 1

● PLAYER OPERATION IN THE TEST MODE

Operate the player by selecting a test mode function with the keys on the player or on the remote control unit.

• CD PLAYBACK

- ① Place the CD disc on the turn table.

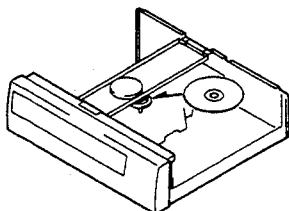

- ② Press the PLAY (▶) key once. (Twin gear starts to move.)
- ③ Push the cam plate (Fig. 4) in the direction of the arrow and wait until the CD disc is clamped.

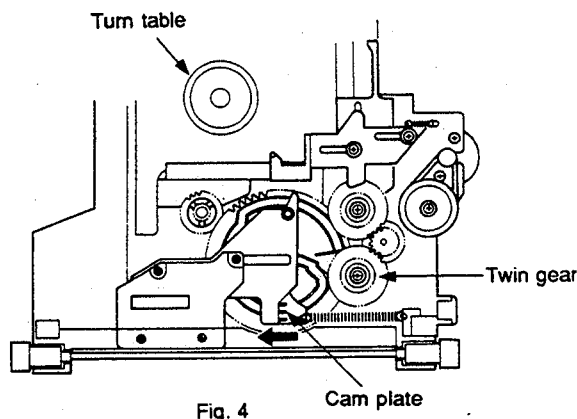

- ④ Press the ◀◀ or ▶▶ keys to appear "S-CD" on the TV screen display.

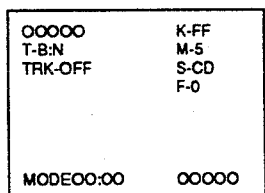

TV screen display

- ⑤ Press the PLAY (▶) key twice, disc will be normally playbacked.

• LD PLAYBACK

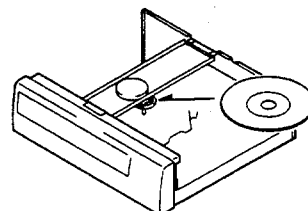

- ① Press the PLAY (▶) key once. (Twin gear starts to move.)
- ② Press the SKIP REV (⏮) key to raise the turn table (spindle motor section) while pressing the cam plate (Fig. 4) in the direction of the arrow. Raise it to the position where the LD disc can be easily placed on the turn table. If the turn table is raised too high, lower it with the SKIP FWD (⏭) key.
- ③ Place the LD disc on the turn table and press the PLAY (▶) key once to clamp the disc.
- ④ Press the ◀◀ or ▶▶ keys to appear "S-LD" on the TV screen display.

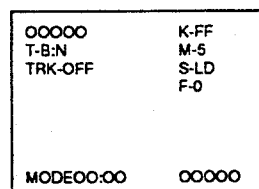

TV screen display

- ⑤ Press the PLAY (▶) key twice, disc will be normally playbacked.

1.6.2 ADJUSTMENT PRECAUTIONS

● JIGS FOR ADJUSTMENT

- CD test disc (STD-901 or STD-902)
- LD test disc (GGV1003 and GGV1007)
- (−) Screwdriver (medium)
- (−) Screwdriver (small)
- Hexagonal wrench driver (straight type, size : 3mm)
- Resistor ($10k\Omega \times 2$, $47k\Omega$)
- Dual-trace oscilloscope (with delay)
- AF oscillator
- Frequency counter
- Digital voltmeter
- TV monitor
- Low-pass filter

Use the low-pass filters below in the coarse centering adjustment 2. and fine centering adjustment (L.P.F.1 and L.P.F.2) 6. and PLL OFFSET adjustment (L.P.F.3) 1. when the S/N of the waveform is hard to observe.

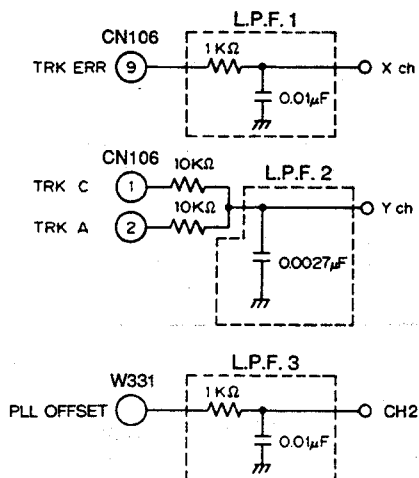

● RACK ASSEMBLY DURING CENTERING ADJUSTMENT

The S-IN position (without hitting the mechanism stopper) of the rack assembly during centering adjustment is indicated below.

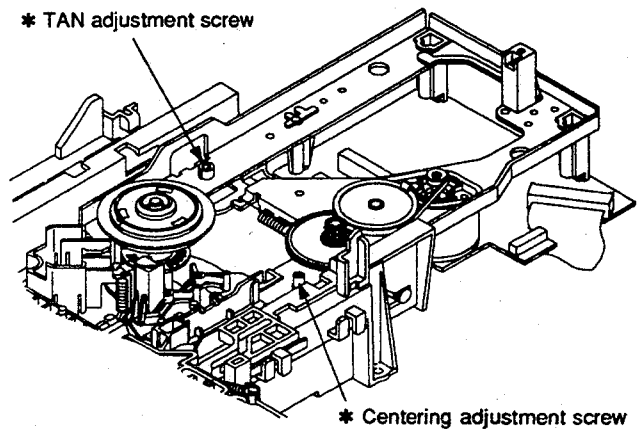
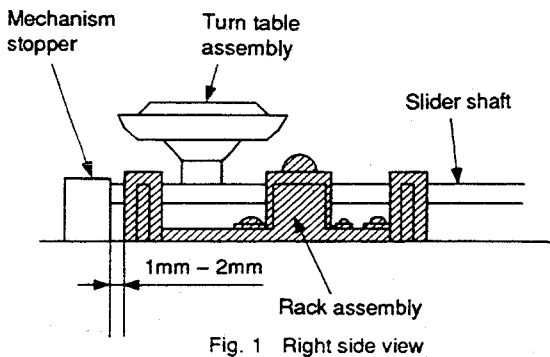

* : As the adjustment range of both the TAN and centering adjustment screws is only $\pm 90^\circ$ from the center, do not turn the screws beyond this range.

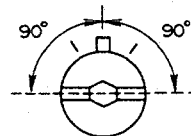
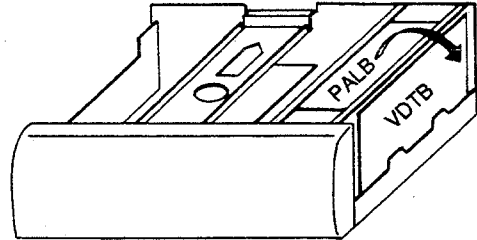

Fig. 2 TILT base section

● **DISASSEMBLY ORDER**
(When diagnosing the MAIN ASSY)

① Remove the tray, open PALB assy, and fix it to the holder.



② Removes SCRB, KFCB and EXTB assy.

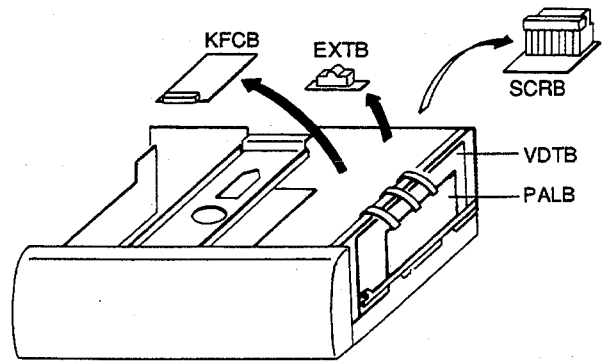

③ Remove VDTB and MAIN assy, and stand MAIN assy up.
 Put isolating material on top of the clasper, and then place the VDTB and PALB assy on top.

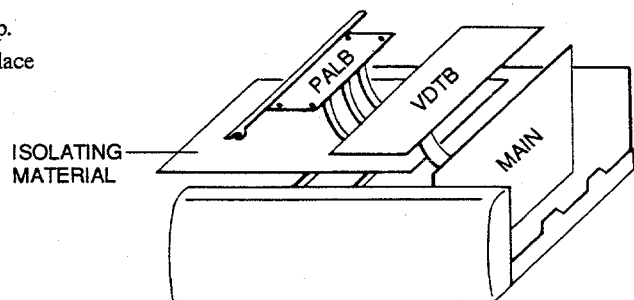

1.6.3 MAIN ASSY, VDTB ASSY AND PALB ASSY ADJUSTMENT LOCATION

● MAIN ASSY

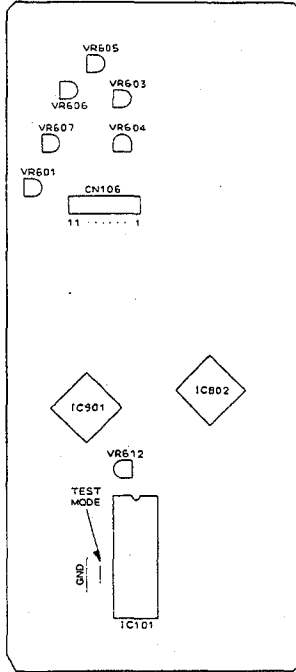

- VR607 : Tilt offset adjustment
 - VR605 : FCS Balance adjustment (TRK error max)
 - VR606 : FCS Balance adjustment (RF level max)
 - VR604 : FCS Servo loop gain adjustment
 - VR603 : TRK Servo loop gain adjustment
 - VR601 : RF level adjustment
 - VR612 : PLL offset adjustment
- (Order in adjustment)

Fig. 1 Adjustment diagram of MAIN ASSY

● VDTB ASSY AND PALB ASSY

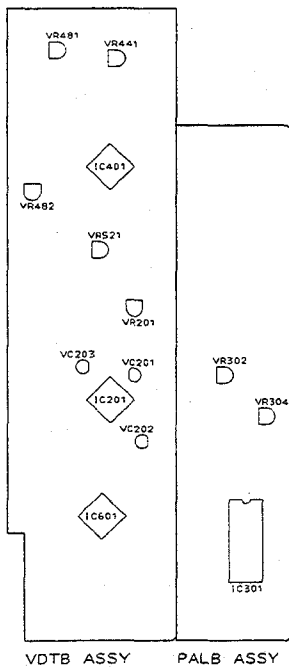

- VC202 : NTSC Reference clock adjustment
 - VC201 : PAL Reference clock 910fH adjustment
 - VC203 : PAL Reference clock adjustment
 - VR481 : VCO Center frequency adjustment
 - VR482 : Output video level adjustment
 - VR441 : 1H Delay video level adjustment
 - VR521 : VPS Error adjustment
 - VR304 : MOD Y - Signal level adjustment
 - VR302 : MOD C - Signal level adjustment
 - VR201 : PAL Inverting SC phase adjustment
- (Order in adjustment)

Fig. 2 Adjustment diagram of VDTB ASSY AND PALB ASSY

1.6.4 MECHANICAL ADJUSTMENT

NOTE : All VRs and CNs (connectors) in the tables are parts of MAIN ASSY.

Adjustment name	Adjustment point	Measuring equipment and jigs	Measurement point	Player condition	Adjustment procedure	Waveform and connection diagram
1 Tilt offset Check and adjustment	VR607	• TV monitor	Tilt indication on Test mode screen	• Power ON • Test mode • Disc not installed	1. Check if the tilt indication on the test mode screen is at T-6 to T-8. 2. If the tilt indication is not at T-6 to T-8, adjust VR607 until the tilt indication reaches T-6 to T-8.	
2 Coarse centering adjustment	Mechanism assembly Centering adjustment screw	• Screwdriver (Large) • Oscilloscope • STD-901 or STD-902 • MIX resistor 	CN106 X : ⑨ pin (TRK ERR) Y : ①+② pin (TRK SUM)	• Test mode TRK servo OFF Tilt servo ON • Innermost track of STD-901 or STD-902 which does not come in contact with the mechanical stopper.	Note : Be careful not to turn the centering adjustment screw past its limit. 1. Move the slider until it does not come in contact with the mechanical stopper at the slider position indication S-IN. 2. Observe TRK ERR (Xch) and TRK SUM (Ych) at the X-Y mode during TRK Servo OFF. 3. Adjust centering adjustment screw until the Lissajous' figure is horizontal.	
3 FCS balance adjustment (1) TRK ERR MAX	VR605	• Oscilloscope • STD-901 or STD-902	CN106 ⑨ pin (TRK ERR)	• Test mode TRK servo OFF Tilt servo ON • Inner track of STD-901 or STD-902	1. Observe TRK ERR at CH1 of the oscilloscope during TRK Servo OFF. 2. Adjust VR605 until the amplitude of the waveform reaches its maximum and the envelope is very clear.	
4 FCS balance adjustment (2) RF LEVEL MAX	VR606	• Oscilloscope • STD-901 or STD-902	CN106 ③ pin (RF)	• Test mode TRK servo ON Tilt servo ON • Inner track of STD-901 or STD-902	1. Observe RF at CH1 of the oscilloscope at TRK Servo ON. 2. Adjust VR606 until the amplitude of the waveform reaches its maximum and the envelope is very clear.	
5 Tangential direction angle adjustment	Carriage assembly TAN adjustment screw	• Oscilloscope • STD-901 or STD-902 • Screwdriver (Medium)	CN106 ③ pin (RF)	• Test mode TRK servo ON Tilt servo ON • Outermost track of STD-901 or STD-902 (position where TAN screw can be seen)	Note : Be careful not to turn the TAN adjustment screw past its limit. 1. Observe RF at CH1 of the oscilloscope at TRK Servo Close. 2. Turn TAN adjustment screw until the amplitude of the waveform reaches its maximum and the envelope is very clear. After adjustment, stabilize the screw with an adhesive.	
6 Fine centering adjustment	Mechanism assembly Centering adjustment screw	• Oscilloscope • STD-901 or STD-902 • MIX resistor 	CN106 X : ⑨ pin (TRK ERR) Y : ①+② pin (TRK SUM)	• Test mode TRK servo OFF Tilt servo ON • Innermost track of STD-901 or STD-902 which does not come in contact with the mechanical stopper.	Note : Be careful not to turn the centering adjustment screw past its limit. Perform fine centering adjustment again by following the same procedure as in "Coarse centering adjustment" (2). After adjustment, stabilize the screw with an adhesive.	
7 Crosstalk check and tilt offset adjustment.	VR607	• TV monitor • GGV1003	Crosstalk check screen	• Test mode TRK servo ON Tilt servo ON • GGV1003still #115	1. Search for address #115 of GGV1003 and still the address 2. Check the crosstalk. If the crosstalk is pronounced, adjust VR607 until the crosstalk is not noticeable.	
When the crosstalk is still noticeable in spite of the adjustment in (7), after carrying out the adjustment in (1) and bringing the tilt indication to T-6 to T-8, use a hexagonal wrench driver (straight type, size : 3mm) to adjust the TAN adjustment screw on the bottom side of the player through the GGV1003 # 115 STILL screen. Afterwards, perform the adjustment procedures from (6).						

Adjustment name	Adjustment point	Measuring equipment and jigs	Measurement point	Player condition	Adjustment procedure	Waveform and connection diagram
8 FCS Servo loop gain adjustment	A VR604	<ul style="list-style-type: none"> Oscilloscope GGV1003 AF Oscillator Resistor (47kΩ) 	CN106 X : ⑦ pin FCS IN Y : ⑥ pin FCS ERR	<ul style="list-style-type: none"> Test mode TRK servo ON Tilt servo ON GGV1003 # 15,000still 	1. Xch : Connect to ⑦ pin with 47kΩ Ych : Connect to ⑥ pin 2. Search #15,000 of GGV1003 and still the address. 3. Connect AF oscillator between Xch and 47kΩ and adjust VR604 until Lissajous' figure is a circle.	
	B VR604	<ul style="list-style-type: none"> Oscilloscope GGV1003 Clip etc. (Short GND—⑦ pin) 	CN106 X : — Y : ⑥ pin FCS ERR ⑦ pin GND (⑦, ⑧ pin Short)	<ul style="list-style-type: none"> Test mode Stop mode F-1 	1. Ych : connect to ⑥ pin. Drop ⑦ pin to GND. 2. Put in GGV1003, press reverse side of skip key and bring F-0 to F-1. 3. Press brake and adjust VR604 until the waveform level is 2.6 Vp-p ± 0.1 V.	
9 TRK Servo loop gain adjustment	A VR603	<ul style="list-style-type: none"> Oscilloscope GGV1003 AF Oscillator Resistor (47kΩ) 	CN106 X : ⑩ pin TRK IN Y : ⑨ pin TRK ERR	<ul style="list-style-type: none"> Test mode TRK servo ON Tilt servo ON GGV1003 # 15,000still 	1. Xch : Connect to ⑩ pin with 47kΩ Ych : Connect to ⑨ pin 2. Search #15,000 of GGV1003 and still the address. 3. Connect AF oscillator between Xch and 47kΩ and adjust VR603 until Lissajous' figure is a circle.	
	B VR603	<ul style="list-style-type: none"> Oscilloscope GGV1003 	CN106 X : — Y : ⑨ pin TRK ERR	<ul style="list-style-type: none"> Test mode TRK servo ON Tilt servo ON F-1 GGV1003 # 15,000still 	1. Ych : connect to ⑨ pin. 2. Search #15,000 of GGV1003 and still the address. 3. Adjust VR603 until the waveform level is 1.6 Vp-p ± 0.1 V.	
10 RF level adjustment	VR601	<ul style="list-style-type: none"> Oscilloscope GGV1003 	CN106 ③ pin (RF)	<ul style="list-style-type: none"> Test mode TRK servo ON Tilt servo ON GGV1003 # 15,000still 	1. Search for address #15,000 of GGV1003, still the address, and observe RF at CH1. 2. Adjust VR601 until RF amplitude is 300mVp-p ± 50 mV.	

1.6.5 ELECTRICAL ADJUSTMENT

ADJUSTMENT TABLE OF MAIN ASSY, VDTB ASSY, PALB ASSY AND YCNR ASSY

Adjustment name	Adjustment point	Measuring equipment and jigs	Measurement point	Player condition	Adjustment procedure	Waveform and connection diagram
1 PLL offset adjustment	VR612 (MAIN ASSY)	<ul style="list-style-type: none"> Oscilloscope DC Volt meter STD-901 or STD-902 (or LDD disc) 	Digital sound terminal W331	<ul style="list-style-type: none"> Test mode Tilt servo ON TRK servo ON/OFF Digital sound play 	<p>With TRK Servo OFF, play digital sound and coarsely adjust VR612 so that sound is produced.</p> <p>Connect W331 and DC voltmeter and while playing digital sound, turn TRK Servo on and off. Adjust VR612 so that DC voltage difference between ON and OFF conditions is $0 \pm 0.1V$.</p>	
2 NTSC Reference clock adjustment	VC202 (VDTB ASSY)	<ul style="list-style-type: none"> Frequency counter GGV1003 	IC201-33(TBC CLK)	<ul style="list-style-type: none"> NTSC PLAY mode. Play the NTSC disc. or Select the NTSC mode with the SYSTEM button of the front panel. (Note1) 	Adjust VC202 so that the 4fsc frequency becomes $14.31818MHz \pm 0.1kHz$.	
3 PAL Reference clock 910fH adjustment	VC201 (VDTB ASSY)	<ul style="list-style-type: none"> Frequency counter GGV1007 	IC201-33(TBC CLK)	<ul style="list-style-type: none"> PAL PLAY mode. Play the PAL disc. or Select the PAL mode with the SYSTEM button of the front panel. (Note1) 	Adjust VC201 so that the 910fH frequency becomes $14.21875MHz \pm 0.1kHz$.	
4 PAL Reference clock adjustment	VC203 (VDTB ASSY)	<ul style="list-style-type: none"> Frequency counter GGV1007 	IC201-24(OSD CLK)	<ul style="list-style-type: none"> PAL PAUSE mode. Play the PAL disc and set to pause state. or Select the PAL mode with the SYSTEM button of the front panel. (Note1) 	Adjust VC203 so that the 4fsc frequency becomes $17.734475MHz \pm 0.1kHz$.	
5 PAL VCXO ERR Offset check	VC201 (VDTB ASSY)	<ul style="list-style-type: none"> Oscilloscope GGV1007 	IC203-1	<ul style="list-style-type: none"> Play the PAL disc. 	<p>Play the PAL disc and check that the voltage of VCXO ERR at IC203-1pin is $0V \pm 100mV$. If the specified voltage is not obtained, adjust VC201 so that the voltage becomes $0V \pm 100mV$.</p> <p>Note : The adjustment of VC201 in this step should have priority over that in step 2.</p>	
6 VCO Center frequency adjustment	VR481 (VDTB ASSY)	<ul style="list-style-type: none"> Oscilloscope GGV1007 	CH1 : C405 lead wire CH2 : C499 + lead wire	<ul style="list-style-type: none"> Normal mode GGV1007 #4,000 still 	Adjust VR481 so that the center position of jitter of CH2 video signal is delayed to $75\mu S(1H + 11\mu S) \pm 1.4\mu S$ as compared with CH1 video signal.	
7 Output video level adjustment	VR482 (VDTB ASSY)	<ul style="list-style-type: none"> Oscilloscope TV monitor GGV1003 	Video output terminal (75Ω termination or TV monitor connection)	<ul style="list-style-type: none"> Normal mode GGV1003 #19,900 still HQ circuit OFF 	Adjust VR482 so that the voltage between the sync tip and the white peak becomes $1.0Vp-p \pm 5\%$.	

Note1 : PAL mode → NTSC mode → MOD PAL mode (Cyclic change)

Adjustment name	Adjustment point	Measuring equipment and jigs	Measurement point	Player condition	Adjustment procedure	Waveform and connection diagram
8 1H Delay video level adjustment	VR441 (VDTB ASSY)	• Oscilloscope • GGV1003	CH1 : C443—(minus) lead wire CH2 : C445—(minus) lead wire	• Normal mode • GGV1003 #19,900 still	Adjust VR441 so that the level of the 1H delay video signal becomes the same as that of the main video signal.	<p>Oscilloscope range CH1:20mV/div 10μs/div CH2:20mV/div AC mode</p> <p>Main video signal CH1 CH2 1H delay video signal</p>
9 VPS Error adjustment	VR521 (VDTB ASSY)	• TV monitor • GGV1003	Video output terminal (TV monitor)	• Normal mode • GGV1003 #8,000 still	Color irregularity on the magenta screen is minimized.	<p>Rear panel Video output TV monitor</p>
10 MOD Y— Signal level adjustment	VR304 (PALB ASSY)	• Oscilloscope • GGV1003	CH1 : IC303—2 (REFERENCE) CH2 : IC303—1	• Normal mode • GGV1003 #19,900 still • HQ circuit ON	Adjust VR304 so that the level of Y signal at IC303—1 pin between the sync tip and the white 100% becomes the same as that of the Y signal at IC303—2 pin.	<p>IC303 ② IC303 ①</p> <p>CH1 CH2</p>
11 MOD C—Signal level adjustment	VR302 (PALB ASSY)	• Oscilloscope • GGV1003	CH1 : IC303—2 (REFERENCE) CH2 : IC303—1	• Normal mode • GGV1003 #8,000 still	Adjust VR302 so that the level of C signal at IC303—1 pin becomes the same as that of the C signal at IC303—2 pin.	<p>IC303 ② IC303 ①</p> <p>CH1 CH2</p>
12 PAL Inverting SC phase adjustment	VR201 (VDTB ASSY)	• TV monitor • GGV1007	Video output terminal (TV monitor)	• Normal mode GGV1007 test disc #6,500 still	Adjust VR201 so that the color irregularity on the magenta screen is minimized at still.	<p>Rear panel Video output TV monitor</p>

Note2 : It is possible to terminate video output terminal with 75Ω by connecting TV monitor.

1.7 PARTS LIST FOR PACKING AND EXPLODED VIEWS

NOTES:

- Parts marked by "NSP" are generally unavailable because they are not in our Master Spare Parts List.
- The Δ mark found on some component parts indicates the importance of the safety factor of the part. Therefore, when replacing, be sure to use parts of identical designation.
- Parts marked by "⊙" are not always kept in stock. Their delivery time may be longer than usual or they may be unavailable.
- Parts list without notice are common for CLD - 160K/HB and CLD - 160K/HEZ.

1.7.1 PACKING

(1) CONTRAST OF CLD - 160K/HB AND CLD - 160K/HEZ.

CLD - 160K/HB and CLD - 160K/HEZ have the same construction except for the following :

Mark	No.	Symbol & Description	Part No.	
			CLD - 160K/HB	CLD - 160K/HEZ
	1	Pad (R)	VHA1123	VHA1106
	3	Packing case	VHG1387	VHG1386
	15	Operating instructions (Dutch/Swedish/Spanish/Portuguese)	Not used	VRF1032
	16	Caution(UC)	VRR1020	Not used
NSP	16	Caution(EW)	Not used	VRM1027
NSP	17	Caution	Not used	VRR1009

(2) FOR CLD - 160K/HB

Mark	No.	Description	Parts No.
	1	Pad (R)	VHA1123
	2	Pad (F)	VHA1149
	3	Packing case	VHG1387
	4	
	5	
	6	Battery cover	PZN1012
	7	Remote control unit	VXX2071
	8	Mirror mat sheet	VHL1006
	9	Audio cord	VDE1033
	10	Video cord	VDE1034
NSP	11	Battery (R03, AAA)	VEM-022
NSP	12	Polyethylene bag	Z21-029
NSP	13	Warranty card	ARW-088
	14	Operating instructions (English/French/German/Italian)	VRE1030
	15	
	16	Caution (UC)	VRR1020
	17	
NSP	18	Polyethylene bag	VHL-014

1.7.2 EXTERIOR SECTION

(1) CONTRAST OF CLD - 160K/HB AND CLD - 160K/HEZ.

CLD - 160K/HB and CLD - 160K/HEZ have the same construction except for the following :

Mark	No.	Symbol & Description	Part No.	
			CLD - 160K/HB	CLD - 160K/HEZ
	32	Caution label	PRW1018	VRW1094
	33	Caution label(HE)	Not used	VRW1297

(2) FOR CLD - 160K/HB

Mark	No.	Description	Parts No.	Mark	No.	Description	Parts No.
	1	Guide plate (L)	VNE1805	NSP	21	Damp cushion	VEC1110
	2	Guide plate (R)	VNE1806		22	
	3	Lock plate spring	VBH1188		23	Screw	BPZ30P060FCU
	4	Lock plate	VNL1513		24	Screw	BPZ30P080FCU
	5	CD tray	VNK1992		25	Screw	BBZ30P080FCC
	6	Tray ASSY - S	VXX2066		26	Screw	BCZ40P060FZK
NSP	7	LD tray	VNK2550		27	Screw	BPZ20P040FZK
	8	Disc pad (L)	VEC1657		28	Screw	VBA1032
	9	Disc pad (C)	VEC1658		29	Tray rubber	VEB1091
NSP	10	Carry label	VRW1289	NSP	30	Cushion	VEC1618
	11	Bonnet case S	VXX1898		31	Caution label(G)	VRW - 329
	12	Door spring	VBH1223		32	Caution label	PRW1018
NSP	13	KARAOKE badge	VAM1034		33	
	14	Tray panel ASSY - S	VXX2128				
	15	CD door	VNK2716				
NSP	16	Tray panel	VNK2836				
	17	Door holder	VNE1905				
	18	Door shaft	VLL1441				
	19	Name plate	VAM1032				
	20	Damper ASSY	VXA2112				

1.7.3 TOP VIEW SECTION

Mark	No.	Description	Parts No.	Mark	No.	Description	Parts No.
	1	Clamper holder	VNL1514		19	Flexible cable (22P)	VDA1448
	2	Rubber sheet	VEB1114		20	Screw	BBZ30P060FMC
	3	Thrust holder	VNL1289	NSP	21	Mechanism ASSY	VWT1108
	4	Clamper head	VNL1615	NSP	22	Caution label (F)	VRW - 328
	5	Clamper	VNL1515	NSP	23	PALB ASSY	VWV1383
	6	Clamp spring	VBH1192		24	
	7	Clamper arm	VNE1804	NSP	25	SCRB ASSY	VWV1384
	8	Stabilizer	VNE1807		26	
	9	Rack ASSY	VWT1099	NSP	27	PCB holder(A)	VNE1875
	10	Carriage shaft	VLL1434	NSP	28	PCB holder(B)	VNE1880
NSP	11	Side stay (R)	VNE1810	NSP	29	P plate holder	PNY - 405
NSP	12	Front angle	VNE1808	NSP	30	Wire clamp (A)	VEC1217
	13	Screw	CPZ20P050FMC		31	Housing ASSY (2P)	VKP2048
	14	Screw	BBZ30P080FCC		32	Flexible cable (28P)	VDA1461
	15	Screw	IBZ30P060FCC		33	Connector ASSY	PF06PP - C20
	16	Screw	IPZ30P060FMC		34	Connector ASSY	PF03PP2C22
NSP	17	Earth plate	VNE1518				
	18	Screw	PCZ30P060FMC				

1.7.4 FRONT PANEL SECTION

Mark No.	Description	Parts No.	Mark No.	Description	Parts No.
NSP 1	Front panel	VNK3003	14	Headphones knob	PAC1707
2	FL panel(4)	VEC1718	NSP 15	TWKB ASSY	VWG1551
3	LED lens	PNW2019	16	Volume holder	VNE1933
4	PW button	VNK2668	17	Cushion	VEC1497
5	L key (L)	VNK2761	18	VR knob (L)	VNK2674
6	L key (R)	VNK2670	19	VR knob (S)	VNK2671
7	Main key	VNK2667	20	Front panel ASSY - S	VXX2192
8	Ten key (R)	VNK2665	21	Screw	BPZ26P080FMC
9	Ten key (L)	VNK2663	22	Plastic rivet	VEC1298
10	FLKB ASSY	VWG1567	NSP 23	NRPB (PC board)	VNZ1546
NSP 11	PONB ASSY	VWG1552	NSP 24	Rubber spacer	VEB1219
12	Slide knob	VNK2675	25	Cushion	VEC1717
NSP 13	JACB ASSY	VWV1396			

1.7.5 BASE SECTION

(1) CONTRAST OF CLD - 160K/HB AND CLD - 160K/HEZ.

CLD - 160K/HB and CLD - 160K/HEZ have the same construction except for the following :

Mark	No.	Symbol & Description	Part No.	
			CLD - 160K/HB	CLD - 160K/HEZ
△	3	SYPS ASSY	VWR1220	VWR1219
	5	Power cord with plug	PDG1055	PDG1003
△	7	Rear panel	VNA1476	VNA1436
	28	Fuse(T5A)	PEK1003	Not used

(2) FOR CLD - 160K/HB

Mark No.	Description	Parts No.	Mark No.	Description	Parts No.
NSP 1	MAIN ASSY	VWX1211	19	Screw	BBZ30P080FCC
△ 2	Cord stopper	CM-22B	20	Screw	BBZ30P040FMC
3	SYPS ASSY	VWR1220	21	Screw	BCZ40P060FZK
4	Tray stopper	VNL1519	22	Screw	BCZ30P080FMC
△ 5	Power cord with plug	PDG1055	23	Screw	BPZ30P140FMC
6	PCB spacer	PNY-404	NSP 24	Heat sink	VNE1854
7	Rear panel	VNA1476	25	PCB holder	VEC1624
△ 8	Fuse (T500mA) (FU3)	REK-097	26	Screw	BCZ30P060FCC
NSP 9	Cord clasper	Z09-060	NSP 27	VDTB ASSY	VWS1141
NSP 10	PCB hinge	VEC1174	△ 28	Fuse(T5A)	PEK1003
△ 11	Power transformer	VTT1138	NSP 29	Rear angle	VNE1844
△ 12	Fuse (T3.15A) (FU1, FU2)	REK-105	NSP 30	Damp cushion	VEC1110
NSP 13	P. plate holder	PNY-405	NSP 31	EXTB ASSY	VWG1559
NSP 14	Side stay (L)	VNE1809	32	KFCB ASSY	VWV1403
NSP 15	Cord clasper	Z09-061	33	Flat cable (10P)	D20PDY1035B
16	Insulator	PNW1912	34	Flat cable (6P)	D20PDY0610G
NSP 17	Base chassis	VNA1255			
18	Insulator ASSY	VXA1881			

1.7.6 MECHANISM SECTION

Mark No.	Description	Parts No.	Mark No.	Description	Parts No.
1	Mechanism base	VNK1990	16	R-SW lever	VNL1506
2		NSP 17	LOSB ASSY	VWG1419
3	Clamp cam	VNL1621	18	Synchro gear ASSY	VXA1822
4	Shaft holder	VNE1817	19	Roller	VNL1042
5	Cam plate	VNL1511	NSP 20	LOMB ASSY	VWG1420
6	CAS spring	VBH1190	21	Loading motor ASSY	VXX1712
7	Cam gear	VNL1507	NSP 22	Slider motor	VXM1033
8	CD plate	VNL1512	23	Motor pulley	PNW1643
9	CDP spring	VBH1191	24	Screw	Z39-019
10	Rubber belt	VEB1184	25	Screw	BMZ26P040FMC
11	Gear pulley	VNL1510			
12	Twin gear	VNL1508			
13	Center gear	VNL1509			
14	L-SW lever	VNL1504			
15	C-SW lever	VNL1505			

1.7.7 MECHANISM ASSY

Mark No.	Description	Parts No.	Mark No.	Description	Parts No.
1	CA belt	VEB1077	16	Y gear	VNL1501
2	CA pulley (2)	VNL1496	17	Tilt cam spring	VBH1189
3	CA gear (3)	VNL1497	18	Tilt cam	VNL1502
4	Tilt base	VNL1499	19	Spindle motor ASSY	VXA2108
5	CA-SW lever	VNL1498	20	Centering hab	VNL1174
NSP 6	CAMB ASSY	VWG1418	21	Centering spring	VBH1083
7	Carriage motor ASSY	VXX1261	NSP 22	Rubber sheet	VEB1103
NSP 8	Carriage motor	VXM1033	NSP 23	Turn table ASSY	VXA1283
9	CA pulley (1)	VNL1197	NSP 24	Oil stopper	VBF1002
NSP 10	PASB ASSY	VWG1417	NSP 25	Spindle motor	VXM1053
11	Radial spring	VBH1201	26	Motor base	VNE1803
12	Thrust spring	VBH1200	27	Screw	BMZ26P040FMC
13	Tilt tension spring	VBH1187	28	Screw	ABZ30P300FMC
NSP 14	FG ASSY	VWG1416	29	Screw	PMA30P050FMC
15	FG. base	VNL1503	30	Washer	WT26D060D025
			31	Housing ASSY	VKP2020

1.7.8 RACK ASSY

Mark No.	Description	Parts No.
NSP 1	Sensor stay	VBK1036
NSP 2	Tilt sensor	SG-302
NSP 3	Pickup ASSY	VWY1036
4	Rack	VNL1495
5	Tan.base	VNL1494
6	Screw	PBB26P080FMC
7	Screw	PMA20P060FMC
8	Screw	PMA20P080FMC
9	Screw	PMH20P040FMC
10	Screw	SMZ20H120FZK

1.8 PCB PARTS LIST

NOTES:

- Parts marked by "NSP" are generally unavailable because they are not in our Master Spare Parts List.
- The Δ mark found on some component parts indicates the importance of the safety factor of the part. Therefore, when replacing, be sure to use parts of identical designation.
- Parts marked by "⊙" are not always kept in stock. Their delivery time may be longer than usual or they may be unavailable.
- When ordering resistors, first convert resistance values into code form as shown in the following examples.

Ex.1 When there are 2 effective digits (any digit apart from 0), such as 560 ohm and 47k ohm (tolerance is shown by J = 5%, and K = 10%).

560Ω	→	56 × 10 ¹	→	561	RD1/8PM	5 6 7 J
47kΩ	→	47 × 10 ³	→	473	RD1/4PS	4 7 3 J
0.5Ω	→	0R5			RN2H	0 R 5 K
1Ω	→	010			RSIP	0 1 0 K

Ex.2 When there are 3 effective digits (such as in high precision metal film resistors).

5.62kΩ	→	562 × 10 ¹	→	5621	RN1/4PC	5 6 2 1 F
--------	---	-----------------------	---	------	-------	---------	---

Mark No.	Description	Parts No.	Mark No.	Description	Parts No.
----------	-------------	-----------	----------	-------------	-----------

LIST OF ASSEMBLIES

NSP	MACBS ASSY	VWM1358
NSP	└─ FG ASSY	VWG1416
NSP	└─ PASB ASSY	VWG1417
NSP	└─ CAMB ASSY	VWG1418
NSP	└─ LOSB ASSY	VWG1419
NSP	└─ LOMB ASSY	VWG1420
	SYPS ASSY(HB TYPE)	VWR1220
	SYPS ASSY(HEZ TYPE)	VWR1219

Note : Although VWR1220 and VWR1219 are different in part number, they have the same service parts.

NSP	FRPB ASSY	VWM1521
	└─ FLKB ASSY	VWG1567
NSP	└─ TWKB ASSY	VWG1551
NSP	└─ PONB ASSY	VWG1552
NSP	└─ JACB ASSY	VWV1396
	MOTHER ASSY	VWM1499
NSP	└─ MAIN ASSY	VWX1211
	VTPB ASSY	VWM1501
NSP	└─ VDTB ASSY	VWS1141
NSP	└─ PALB ASSY	VWV1383
NSP	└─ SCRB ASSY	VWV1384
NSP	KRAB ASSY	VWM1512
NSP	└─ EXTB ASSY	VWG1559
	└─ KFCB ASSY	VWV1403

MACBS ASSY

OTHERS	PCB(MACBS)	VNP1396
--------	------------	---------

FG ASSY

SEMICONDUCTORS	D1 Photo interruptor	GP1S51V
----------------	----------------------	---------

OTHERS	HOUSING ASS'Y	VKP1950
--------	---------------	---------

PASB ASSY

SWITCHES AND RELAYS	S4, S5	DSG1015
---------------------	--------	---------

OTHERS	HOUSING ASS'Y	VKP1951
--------	---------------	---------

CAMB ASSY

SEMICONDUCTORS	Q10	2SC1740S
----------------	-----	----------

RESISTORS	R10	RD1/4VM182J
	R11	RD1/4VM470J
	Other Resistors	RD1/6PM□□□J

OTHERS	CN403 22P Connector	52045-2245
	CN404 Connector post	B3B-PH-K-S
	CN402 KR Connector	B3B-PH-K-R
	CN401 23P FFC Connector(Top)	SLEM23S-2
	HOUSING ASS'Y	VKP2009

LOSB ASSY

SWITCHES AND RELAYS	S1 - S3	DSG1015
---------------------	---------	---------

LOMB ASSY

CAPACITORS	C1	CGCYX473M25
------------	----	-------------

OTHERS	4P Cable holder	51048-0400
	J55 2mm Pitch flat cable(6P)	D20PWY0615G

SYPS ASSY

SEMICONDUCTORS	Δ IC205	ICP-N10
	Δ IC204	ICP-N15
	Δ IC201-IC203	ICP-N20
	Δ IC2	NJM4558D
	Δ IC1	NJM78L05A

Mark	No.	Description	Parts No.	Mark	No.	Description	Parts No.
△	IC41	Q22,Q23,Q29,Q5	NJM78M12FA	FLKB ASSY			
△	Q60,Q61	Q31	2SA933S	SEMICONDUCTORS			
△	Q25,Q27	Q26,Q28	2SB1185	IC501		NJM4558D	
	Q21,Q24,Q4	Q32	2SB1240	IC101		PD3286B	
△	Q3	Q30	2SB1566	IC102		S-806D	
△	Q26,Q28		2SC1740S	Q102		DTA144ES	
△	Q26,Q28		2SD1762	Q101,Q104-Q109		DTC114ES	
△	Q32		2SD2395				
△	Q30		DTC114TS	D101-D107,D118		1SS252	
			DTC124ES	D114,D119,D120		SEL6410E-TS	
				D113,D115,D116		SEL6910A--TS	
△	D23,D26		10ELS2	SWITCHES AND RELAYS			
△	D3,D41,D42		11ES2	S101-S108,S110,S112-S115		RSG1030	
△	D2,D24,D25		1SR35-100AVL	CAPACITORS			
△	D21,D22		1SS254	C114,C117		CCPUSL330J50	
△	D7		MTZJ12B	C105		CEAL100M16	
△	D1		S4VB20F	C101		CEAL100M50	
				C103,C113		CEAL101M6R3	
				C503		CFTYA104J50	
				C106,C109		CKPUYB102K50	
				C504		CKPUYB271K50	
				C104		CKPUYF223Z25	
				C102,C107,C108,C112		CKPUYY103N16	
				C501,C502		CKPUYY103N16	
				RESISTORS			
				R122		RN1/6PQ5101F	
				VR101,VR501,VR502 (2K · B)		VC S1034	
				Other Resistors		RD1/6PM□□□J	
				OTHERS			
				CN105	FJ Connector(8P)	08R-FJ	
				CN101	6P Jumper connector	52147-0610	
				CN102	9P Jumper connector	52147-0910	
				CN106	Board to board connector(9P)	9133S-09A	
				CN501	2mm Pitch bottom connector plug	BTMK08P-1R	
					Remote sensor	GP1U58X	
				V101	FL Tube	VAW1034	
					Spacer	VEC1599	
					PCB Binder	VEF1008	
					FL Holder	VNF1085	
				X101	Ceramic resonator	VSS1031	
				TWKB ASSY			
				SWITCHES AND RELAYS			
				S701-S720		RSG1030	
				OTHERS			
				CN701	2.5mm Pitch pin header	1068-09C-PP	
				PONB ASSY			
				SEMICONDUCTORS			
				Q201		DTC114ES	
				D201		SEL6C10S-TS	
				SWITCHES AND RELAYS			
				S202		RSG1030	
				S201		VSH1005	
				FRPB ASSY			
				OTHERS			
				PCB(FRPB)		VNP1481	

Mark No.	Description	Parts No.	Mark No.	Description	Parts No.
CAPACITORS					
C201		CKPUYY103N16	Q103,Q206,Q217,Q502,Q503		DTC124EK
RESISTORS			D202		11EQS06
VR201	(2K · B)	VCS1034	D102,D502,D520,D905		1SS254
	Other Resistors	RD1/6PM□□□J	D963,D964		1SS254
OTHERS			D201		FC54M
CN201	FJ Connector(8P)	08P-FJ	COILS AND FILTERS		
JACB ASSY			L802-L804		LAU121J
SEMICONDUCTORS			L351		LAU181J
IC601		NJM2068D	L201-L205,L352,L800,L801		LAU220J
COILS AND FILTERS			F201,F206-F208		VTH1016
L601		LFA221J	SWITCHES AND RELAYS		
F602-F609		VTH1016	S201		VSH1009
CAPACITORS			CAPACITORS		
C614,C615		CEJA101M10	C159,C809,C811		CCSQCH100D50
C613,C616		CKCYF473Z50	C108,C109,C258,C259,C370		CCSQCH101J50
C611,C612		CKPUYB101K50	C814,C846,C848		CCSQCH121J50
C617		CKPUYB102K50	C232		CCSQCH150J50
C605,C608,C610,C630		CKPUYX122M16	C161,C353,C810		CCSQCH151J50
C601,C602		CKPUYY103N16	C352		CCSQCH180J50
RESISTORS			C812		CCSQCH221J50
VR601	(0.5KB)	VCS1035	C371		CCSQCH270J50
	Other Resistors	RD1/6PM□□□J	C208,C209		CCSQCH271J50
OTHERS			C106,C107,C354,C813		CCSQCH330J50
CN603	2mm Pitch bottom connector	BTMK08S-1S	C351,C931		CCSQCH390J50
JA604	Headphone jack	RKN1002	C260-C263,C963		CCSQCH470J50
JA602	Headphone jack	RKN1006	C375,C806		CCSQCH680J50
CN602	KR Connector	S4B-PH-K-S	C374		CCSQCH820J50
JA601,JA603	Mic jack	VKN1147	C902		CEAL2R2M50
	Snap plate	VNE1102	C893,C933		CEAL470M6R3
	Jack holder(FE)	VNE1932	C871		CEALNP100M16
MAIN ASSY			C522		CEANP100M16
SEMICONDUCTORS			C926		CEANP2R2M50
IC202,IC205,IC903		BA4560F	C838		CEANP470M6R3
IC351		CA0002AM	C904		CEAS010M50
IC803		LA6510L	C228,C367,C845		CEAS100M50
IC802		LC78681E	C225,C226,C256,C364		CEAS101M10
IC206		NJM78L08A	C274,C275		CEAS220M10
IC207		NJM79L08A	C227,C281		CEAS2R2M50
IC801		PAC002A	C101,C230,C252,C253,C363		CEAS470M10
IC901		PAC003A	C369,C801,C803,C833,C836		CEAS470M10
IC101		PD0193A	C842,C844,C927,C974,C975		CEAS470M10
IC201		PD2026B(L)	C207,C255,C257,C270,C271		CEAS471M10
IC902		TA8464K	C279		CEAS471M10
Q102,Q154,Q802,Q963		2SA1037K	C368,C913		CEASR47M50
Q501		2SA933S	C970		CEHAQ010M50
Q834		2SB1237X	C967,C968		CEHAQ100M50
Q201,Q202,Q801,Q805		2SC2412K	C987		CEHAQ220M50
Q903-Q905,Q907,Q913		2SC2412K	C278,C282		CFTXA152J50
Q152,Q803,Q804		2SC3802K	C365,C908,C910		CFTYA104J50
Q204,Q205,Q214		2SD2144S	C359,C360,C905		CFTYA224J50
Q962		2SK184	C521		CFTYA563J50
Q207,Q208,Q216		DTA124EK	C891,C914,C936,C969		CKSQYB102K50
			C110,C888,C907		CKSQYB222K50
			C361,C362		CKSQYB392K50
			C355-C358		CKSQYB472K50
			C105,C122,C160,C213,C231		CKSQYF103Z50
			C234,C251,C286,C288,C376		CKSQYF103Z50
			C523,C807,C834,C835,C843		CKSQYF103Z50

Mark No.	Description	Parts No.	Mark No.	Description	Parts No.	
	C872,C876,C894,C929 C961,C962 C102,C151,C196-C198,C215 C254,C284,C285,C305 C308,C309,C366,C372,C373	CKSQYF103Z50 CKSQYF103Z50 CKSQYF104Z25 CKSQYF104Z25 CKSQYF104Z25	VDTB ASSY			
	C802,C804,C831,C832 C840,C841,C873,C874,C892 C901,C915,C928,C932,C981 C837,C930 C103,C210,C214,C808,C815	CKSQYF104Z25 CKSQYF104Z25 CKSQYF104Z25 CKSQYF333Z25 CKSQYF473Z25	SEMICONDUCTORS			
	C847,C875,C877,C911,C912 C925,C964,C971,C983,C984 C934 C903,C909	CKSQYF473Z25 CKSQYF473Z25 CQMA122J50 CQMA222J50	IC203,IC602 IC403 IC404 IC401 IC201		BA4560F CXL1009P PA0017-P PA5013A PD3239A	
RESISTORS			IC402 IC601 IC202		PM0001 PM3002 TC7SU04F 2SA1037K 2SA1037K	
Δ	R241,R242 (4R7,1/6W) R192,R193 R505 R180 R212,R213,R220,R221	DCN1001 RD1/6PM220J RD1/6PM331J RD1/6PM333J RD1/6PM470J	Q204,Q207,Q406,Q407,Q411 Q456,Q496,Q502,Q511			
	R839,R840 R501 R909 R502 R507	RD1/6PM470J RD1/6PM471J RD1/6PM473J RD1/6PM563J RD1/6PM822J	Q703,Q704 Q401 Q431 Q202,Q203,Q205,Q206,Q209 Q404,Q408,Q497-Q501		2SA1037K 2SB1237X 2SC1740S 2SC2412K 2SC2412K	
	R259-R262 VR606 VR601 VR605 VR603	RN1/10SE473D VRTB6VS153 VRTB6VS222 VRTB6VS333 VRTB6VS472	Q601-Q605,Q608,Q700-Q702 Q409 Q402 Q201,Q403,Q405,Q606,Q609 Q621-Q623		2SC2412K 2SC3802K 2SD1858X DTA124EK DTA124EK	
	VR604,VR607,VR612	VRTB6VS473	Q607,Q610,Q612,Q613 Q624,Q625 D401,D601,D602,D609,D610 D201 D203		DTC124EK DTC124EK 1SS254 DAN202K SVC201SPA	
	Other Resistors	RS1/10S□□□J	COILS AND FILTERS			
OTHERS			L203,L204,L208,L412-L415 L521 L430 L497 L201,L202,L209		LAU120J LAU120J LAU150J LAU151J LAU1R2J	
	3P Cable holder 5P Cable holder 11P Cable holder	51048-0300 51048-0500 51048-1100	L496,L701 L702 L525 L523 L432		LAU220J LAU270J LAU330J LAU390J LAU430J	
CN103	22P Connector	52045-2245	L433 L522		LAU470J LAU560J	
CN303	6P Jumper connector	52147-0610	L411,L431 L458 L457,L524		LAU680J LFA221J LFA561J	
CN302	2mm Pitch wafer	53064-1010	F201		VTF1051	
CN106	11P Top post	B11P-SHF-1AA	CAPACITORS			
CN516	KR Connector	B3B-PH-K-R	C203,C431,C438,C441		CCSQCH050C50	
CN110	5P Top post	B5B-EH	C207,C231,C241,C415,C417		CCSQCHI00D50	
CN101	KR Connector	B5B-PH-K-S	C500,C532,C774		CCSQCHI00D50	
CN504	KR Connector	B6B-PH-K-S	C212,C419,C461,C496		CCSQCHI01J50	
J4	2mm Pitch flat cable(3P)	D20PDY0345G	C430		CCSQCHI20J50	
JA3,JA4	Remote control jack	RKNI004	C456		CCSQCHI21J50	
CN105	2mm Pitch jumper connector(6P)	SBRK06S-4	C439,C440,C516,C520		CCSQCHI50J50	
CN501	1.0mm Pitch FFC Connector	SLW28S-1C7	C509,C550,C771,C772		CCSQCHI51J50	
JA6	PCB Binder 2P Pin jack Screw terminal IC Heat sink(AL) Earth plate	VEF1040 VKB1031 VNE1841 VNE1921 VNF-091	C409,C423,C424,C485,C529 C612,C633		CCSQCHI80J50 CCSQCHI80J50	
X101	Ceramic resonator	VSS1040				
X201	Crystal resonator(16MHz)	VSS1057				

Mark No.	Description	Parts No.	Mark No.	Description	Parts No.
C410,C437		CCSQCH220J50	RESISTORS		
C204,C208,C416,C495,C510		CCSQCH270J50	R496		RD1/6PM101J
C775,C779		CCSQCH270J50	R406		RD1/6PM224J
C402,C463,C507,C508		CCSQCH271J50	R403		RD1/6PM271J
C206,C240,C462		CCSQCH330J50	R431		RD1/6PM510J
			R512		RD1/6PM680J
C211,C433,C524,C528		CCSQCH390J50			
C406		CCSQCH391J50	R612,R613		RN1/10SE103D
C205,C239,C455		CCSQCH470J50	R771		RN1/10SE202D
C549,C778		CCSQCH560J50	R475,R521		RN1/10SE562D
C411,C412,C498,C609		CCSQCH820J50	R438		RN1/6PQ1803F
			R511		RN1/6PQ2002F
C536		CCSQCH910J50			
C651		CCSQSL102J50	R415,R416		RN1/6PQ3002F
C530		CEANP100M25	R434		RN1/6PQ5101F
C551,C613,C620		CEANP220M10	VR201		VRTB6VS222
C537		CEAS010M50	VR441		VRTB6VS223
			VR481,VR482,VR521		VRTB6VS472
C472,C477		CEAS3R3M50		Other Resistors	RS1/10S□□□J
C484,C522		CEJA100M16			
C473		CEJA3R3M50			
C201,C213,C220-C222,C227		CEJA470M6R3	OTHERS		
C428,C434,C445,C452,C457		CEJA470M6R3		5P Cable holder	51048-0500
				7P Cable holder	51048-0700
C474,C489,C490,C499		CEJA470M6R3		12P Cable holder	51048-1200
C501,C502,C512,C521,C525		CEJA470M6R3	CN603	1.0mm Pitch FFC Connector	SLW28S-1C7
C533,C622,C624,C643,C647		CEJA470M6R3		PCB Binder	VEF1040
C675,C676		CEJA470M6R3			
C401,C405,C619		CEJANP2R2M50	JA14	1P Pin jack	VKB1063
				Screw terminal	VNE1841
C443,C625,C628		CEJANP4R7M16	X202	Crystal resonator(14.32MHz)	VSS1029
C223		CEJANPR47M50	X203	Crystal resonator(17.734MHz)	VSS1059
C446,C618		CFTYA103J50	X201	Crystal resonator(14.22MHz)	VSS1060
C514		CFTYA104J50			
C224		CFTYA223J50			
				PALB ASSY	
C471,C603		CFTYA224J50		SEMICONDUCTORS	
C610,C617		CFTYA563J50	IC303		BU4053BCF
C515,C517		CFTYA683J50	IC301		M50552-132SP
C202,C209,C214-C217		CKSQYF103Z50	IC302		TA7320P
C225,C226,C230,C232,C233		CKSQYF103Z50	Q303,Q310,Q363,Q951		2SA1037K
			Q361,Q365		2SC1740S
C242,C414,C418,C421,C422		CKSQYF103Z50			
C425,C426,C458-C460		CKSQYF103Z50	Q308,Q309,Q311,Q352,Q353		2SC2412K
C475,C476,C486,C535,C602		CKSQYF103Z50	Q355,Q356,Q359,Q360		2SC2412K
C604,C615,C616,C621,C644		CKSQYF103Z50	Q952,Q953		2SC2412K
C776,C777,C780,C781,C783		CKSQYF103Z50	Q304,Q307,Q317,Q351		DTA124EK
			Q305,Q306,Q318		DTC124EK
C403,C404,C427,C429,C435		CKSQYF104Z25			
C442,C479-C481,C483		CKSQYF104Z25	D302		DAP202K
C503-C506,C511,C513,C526		CKSQYF104Z25		COILS AND FILTERS	
C531		CKSQYF104Z25	L302,L303,L355,L951,L952		LAU120J
C407,C408,C466,C467		CKSQYF473Z25	L304		LAU220J
			F951		VTF1011
C487,C488,C527,C601,C629		CKSQYF473Z25	F303		VTF1034
C219,C605-C607,C626		CQMA102J50	F952		VTF1064
C608		CQMA152J50			
C627		CQMA222J50			
C444,C611		CQMA272J50		CAPACITORS	
			C356,C364,C392,C958		CCSQCHI101J50
C614		CQMA332J50	C327,C959		CCSQCHI51J50
C218		CQMA472J50	C957		CCSQCH221J50
VC201		PCMI001	C325		CCSQCH330J50
VC202		VCM-008	C326		CCSQCH390J50
VC203		VCM1005			

Mark No.	Description	Parts No.	Mark No.	Description	Parts No.
C960		CCSQCH820J50	OTHERS		
C352		CCSSQL391J50		4P Cable holder	51048-0400
C383		CEALNP470M6R3	J401	2mm Pitch flat cable(4P)	D20PDY0410B
C384		CEANP220M10	JA401	2P Pin jack	VKB1031
C951,C952		CEANP470M10		PCB Holder(S)	VNE1952
C953,C955		CEAS470M16	KFCB ASSY		
C319,C323,C336,C354,C358		CEJA470M6R3	SEMICONDUCTORS		
C360,C362,C373,C375		CEJA470M6R3	IC101,IC102,IC105,IC106		BA4560F
C380-C382,C386,C388,C390		CEJA470M6R3	IC103		BU4053BCF
C318,C320-C322,C324		CKSQYF103Z50	IC107		MB81464-12P
C328,C329,C335,C351,C353		CKSQYF103Z50	IC104		PM0005A
C355,C357,C359,C361,C363		CKSQYF103Z50	Q102		2SD2144S
C369,C374,C376,C385,C954		CKSQYF103Z50	Q101		DTC124EK
C956		CKSQYF104Z25	D103-D105		DA204K
C389,C391			COILS AND FILTERS		
RESISTORS			L102		LFA100K
R387		RD1/6PM101J	L103		LFA3R9J
R355,R361		RD1/6PM470J	L104		LFA102J
R316		RN1/10SE562D	CAPACITORS		
VR304		VRTB6VS222	C135-C139		CCSQCHI00D50
VR302		VRTB6VS471	C120,C152-C154		CCSQCH101J50
Other Resistors		RS1/10S□□□J	C133		CCSQCHI81J50
OTHERS			C111,C115		CCSQCH680J50
7P Cable holder		51048-0700	C101,C102		CEALNP010M50
12P Cable holder		51048-1200	C105,C106		CEALNP100M16
CN302 KR Connector		B3B-PH-K-R	C141		CEAS102M6R3
CN303 KR Connector		B6B-PH-K-S	C125,C127,C134		CEJA100M16
CN301 3P Side post		B53P-SHF-1AA	C148,C149		CEJA101M10
C330,C331 Chip capacitor		CCSSQL102J50	C147		CEJA101M6R3
SCRB ASSY			C126		CEJA330M16
SEMICONDUCTORS			C112,C118		CEJA470M6R3
Q181		2SC1740S	C128		CFTYA104J50
CAPACITORS			C110,C114,C132		CFTYA223J50
C183,C184		CCSQCH271J50	C119		CFTYA473J50
C181,C182		CEAS470M16	C109,C113		CKSQYB332K50
C186		CEAS471M10	C131		CKSQYB472K50
C187,C188		CKSQYB103K50	C103,C104,C108,C116,C117		CKSQYF103Z50
C185		CKSQYF104Z25	C123,C124,C129,C130,C140		CKSQYF103Z50
RESISTORS			C142-C146,C150,C151		CKSQYF103Z50
△ R185 (47,1/6W)		DCN1003	RESISTORS		
R189		RD1/6PM103J	All Resistors		RS1/10S□□□J
R184		RD1/6PM391J	OTHERS		
R186		RD1/6PM750J	CN106	2mm Pitch bottom connector	52084-1010
Other Resistors		RS1/10S□□□J	CN105	6P Jumper connector	52147-0610
OTHERS			J904	Connector	PF04PG-D37
JA181 Connector		VKB1037		PCB Binder	VEF1040
KRAB ASSY					
OTHERS					
PCB(KRAB)		VNP1480			
EXTB ASSY					
CAPACITORS					
C401,C402		CCSQCH331J50			

Service Manual

ORDER NO.
RRZ1160

The chapter 1 of this Service Manual will not be reprinted. On your additional orders, we may supply only the chapter 2. For the chapter 1, please make copies and attach to the chapter 2 at your side if necessary.

CD CDV LD PLAYER

CLD-160K

CHAPTER 2

CONTENTS

CHAPTER 2

2.1 PACKING AND EXPLODED VIEWS ...	2-3
2.2 SCHEMATIC AND PCB CONNECTION DIAGRAMS	2-12

2.1 PACKING AND EXPLODED VIEWS

2.1.1 PACKING

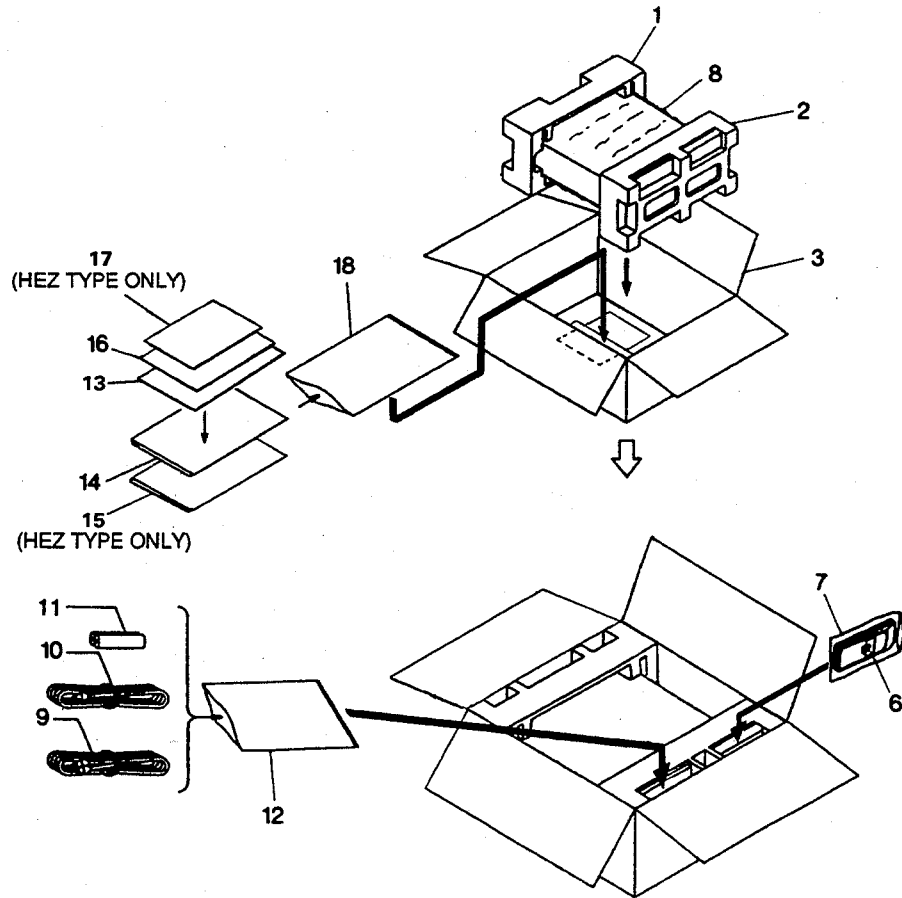

CLD-160K

2.1.2 EXTERIOR SECTION

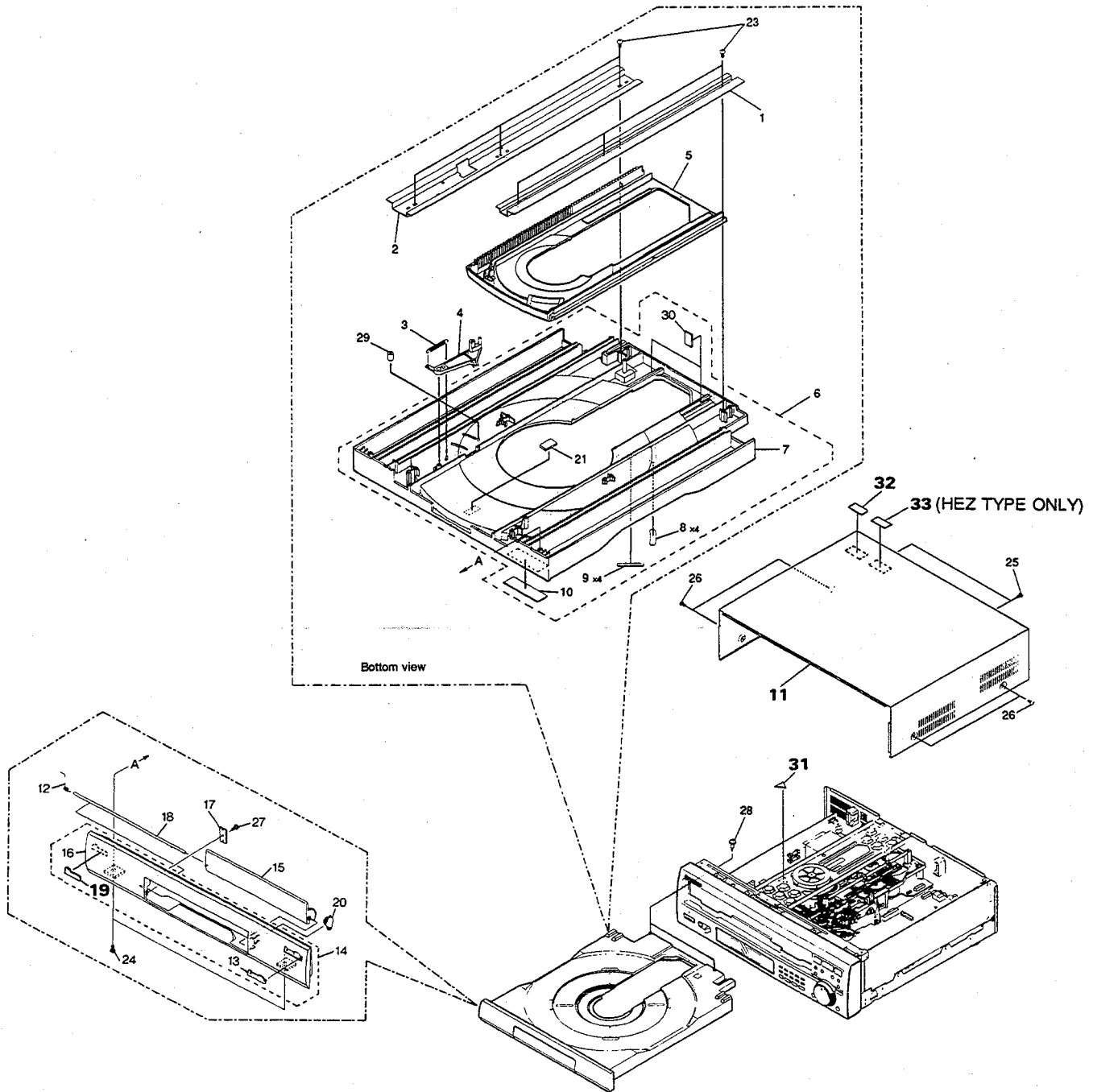

NOTE: Screws adjacent to ▼ mark on product are used for disassembly.

2.1.3 TOP VIEW SECTION

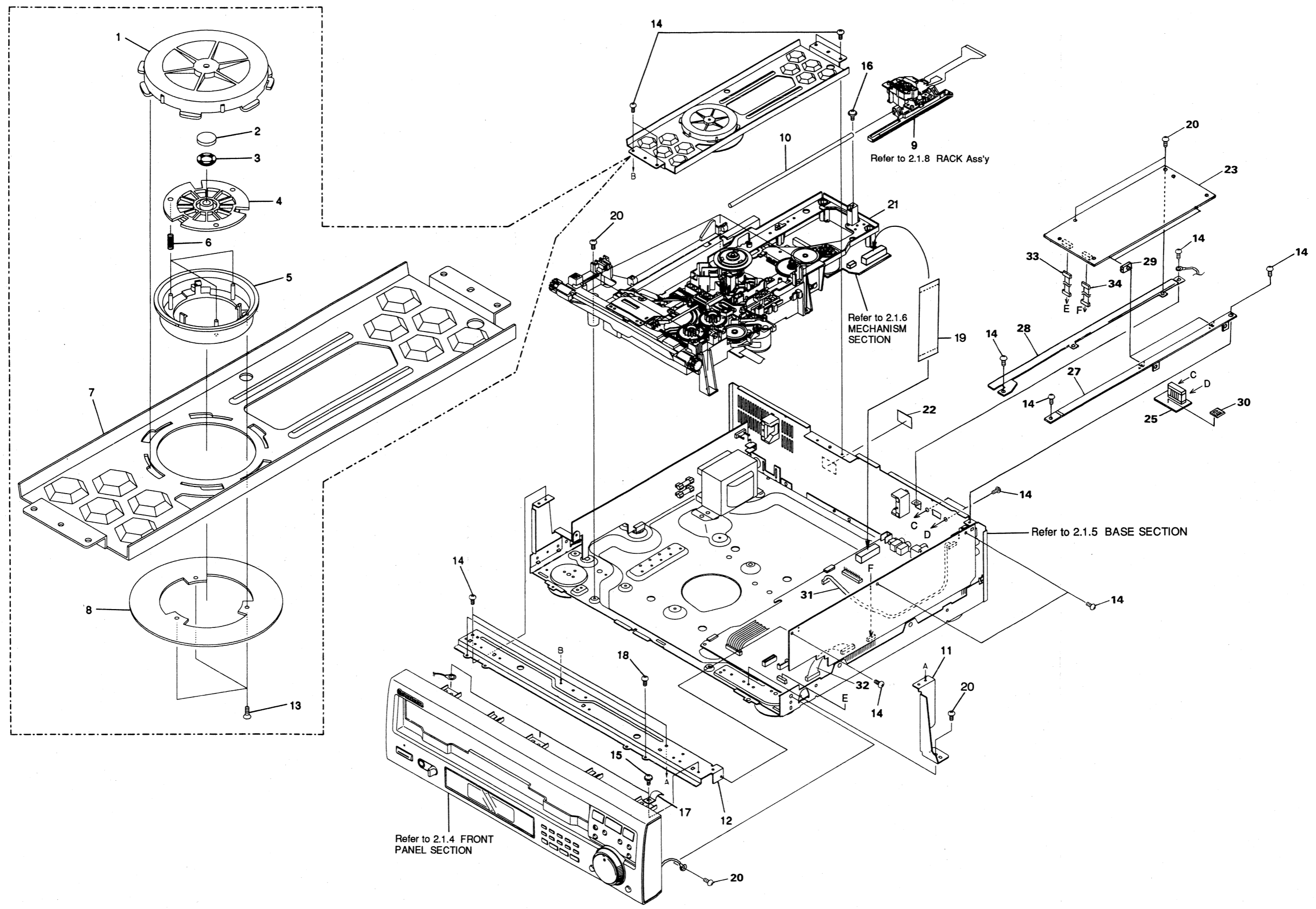

2.1.4 FRONT PANEL SECTION

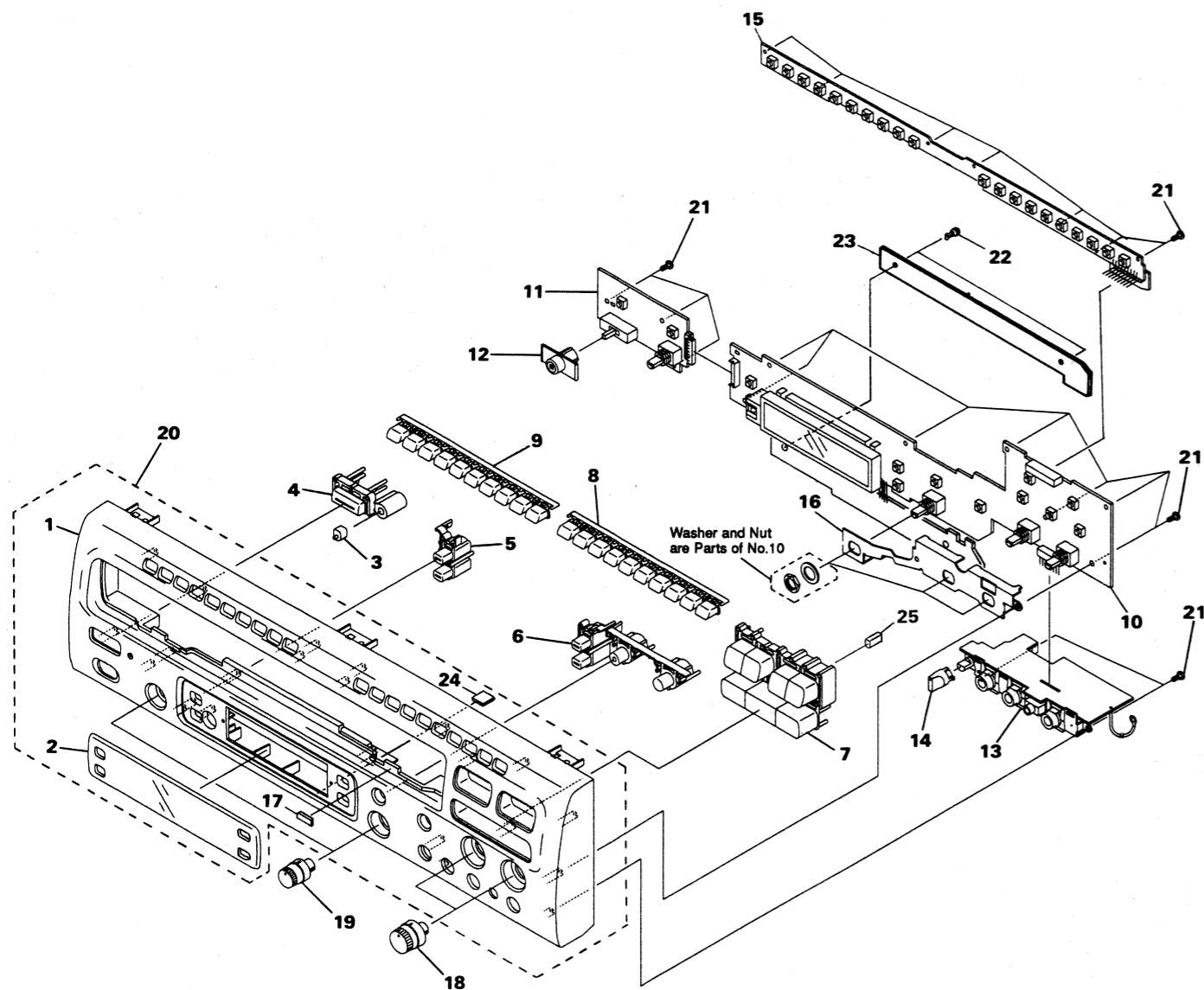

2.1.5 BASE SECTION

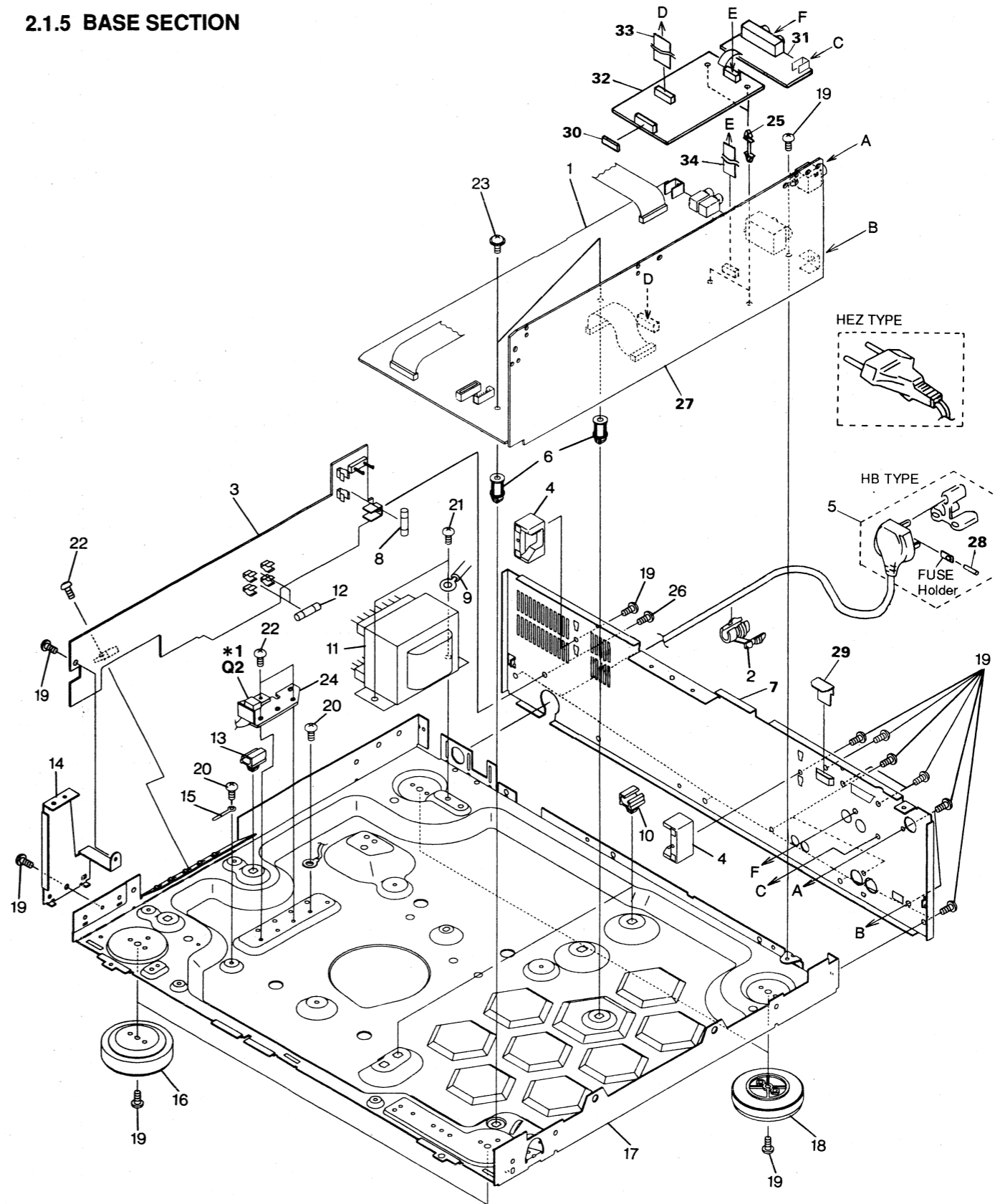

Note:
 * 1 : Q2 is component of the SYPS Ass'y.

2.1.6 MECHANISM SECTION

Refer to 2.1.7 MECHANISM Ass'y

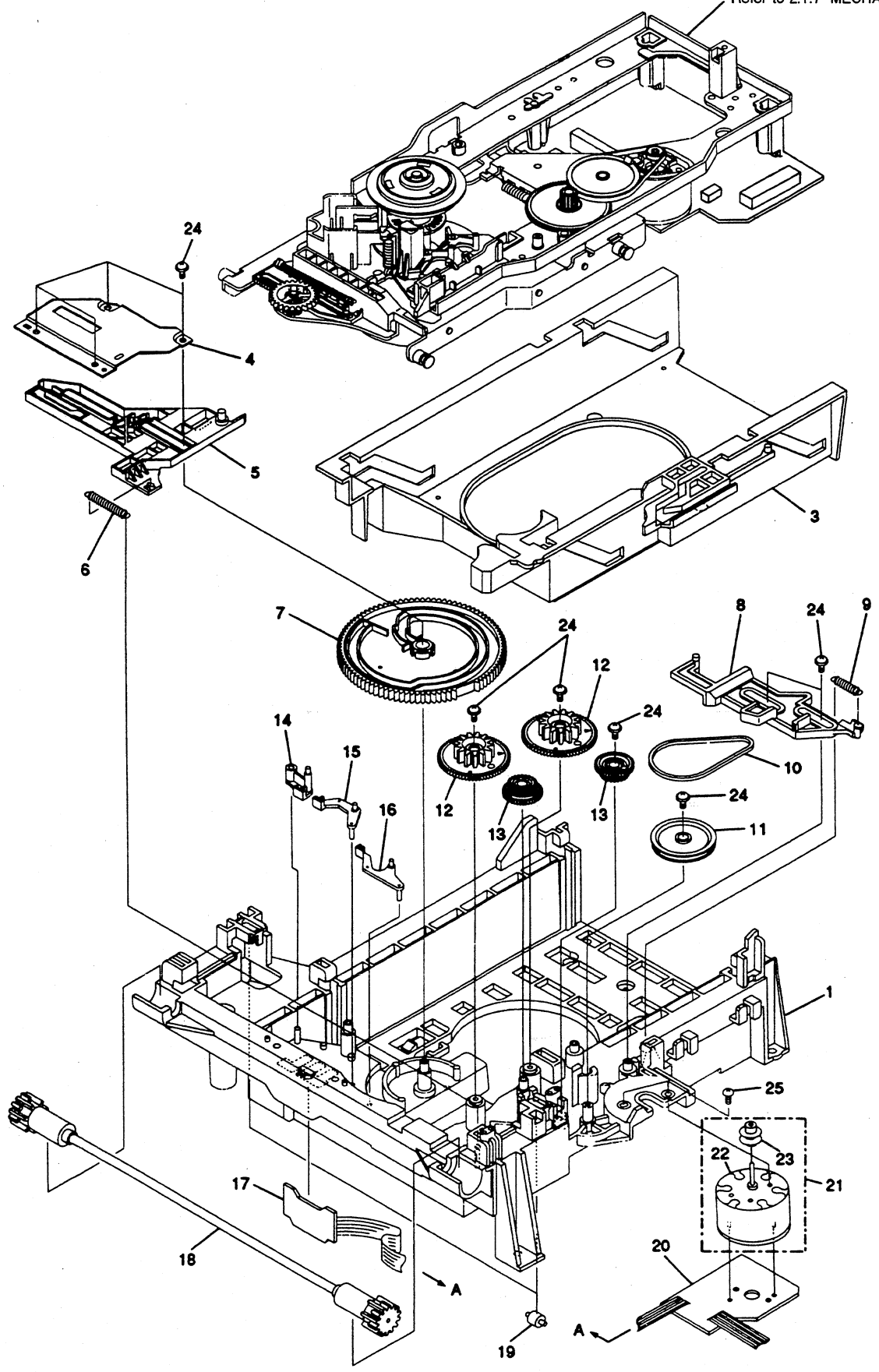

2.1.7 MECHANISM ASSY

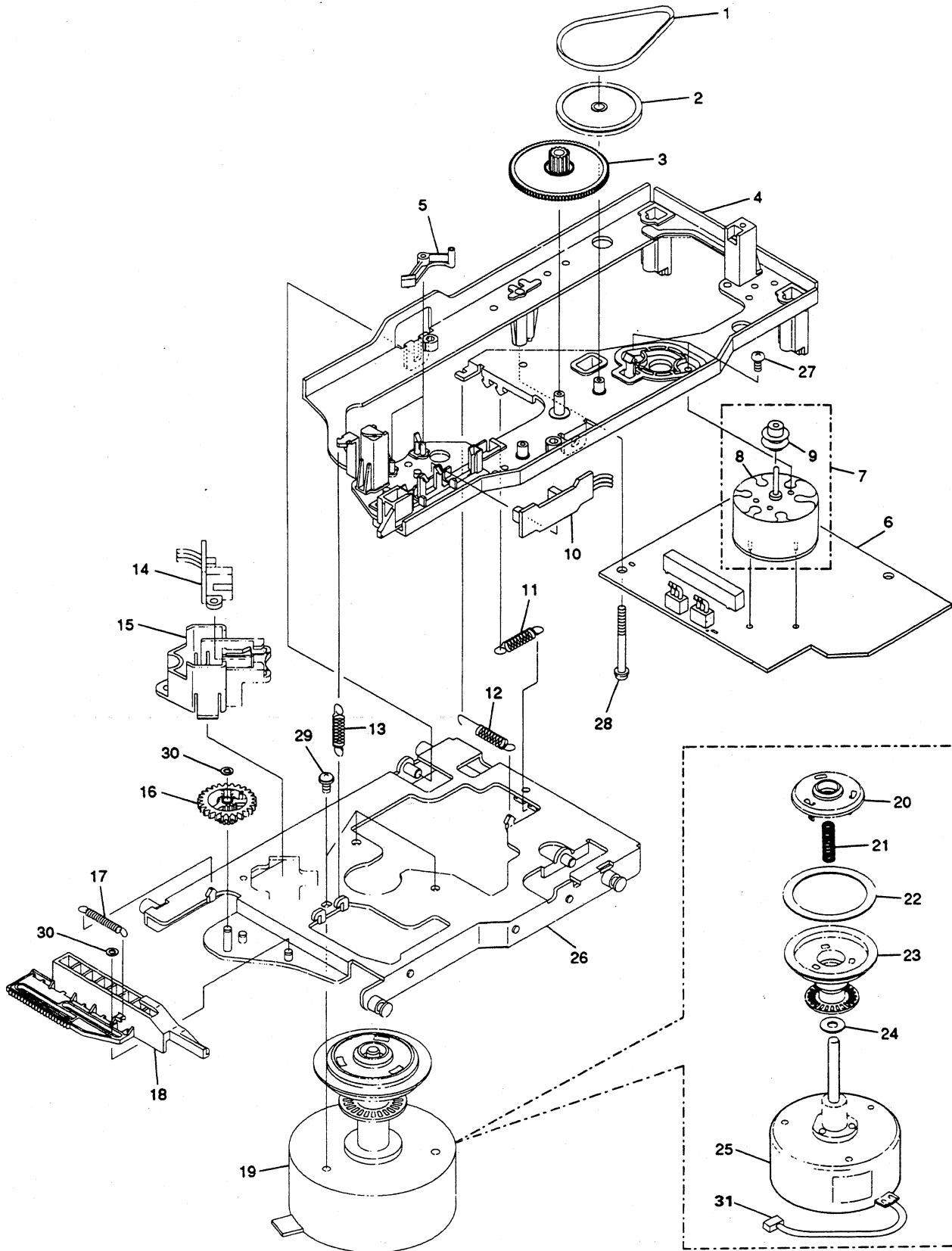

2.1.8 RACK ASSY

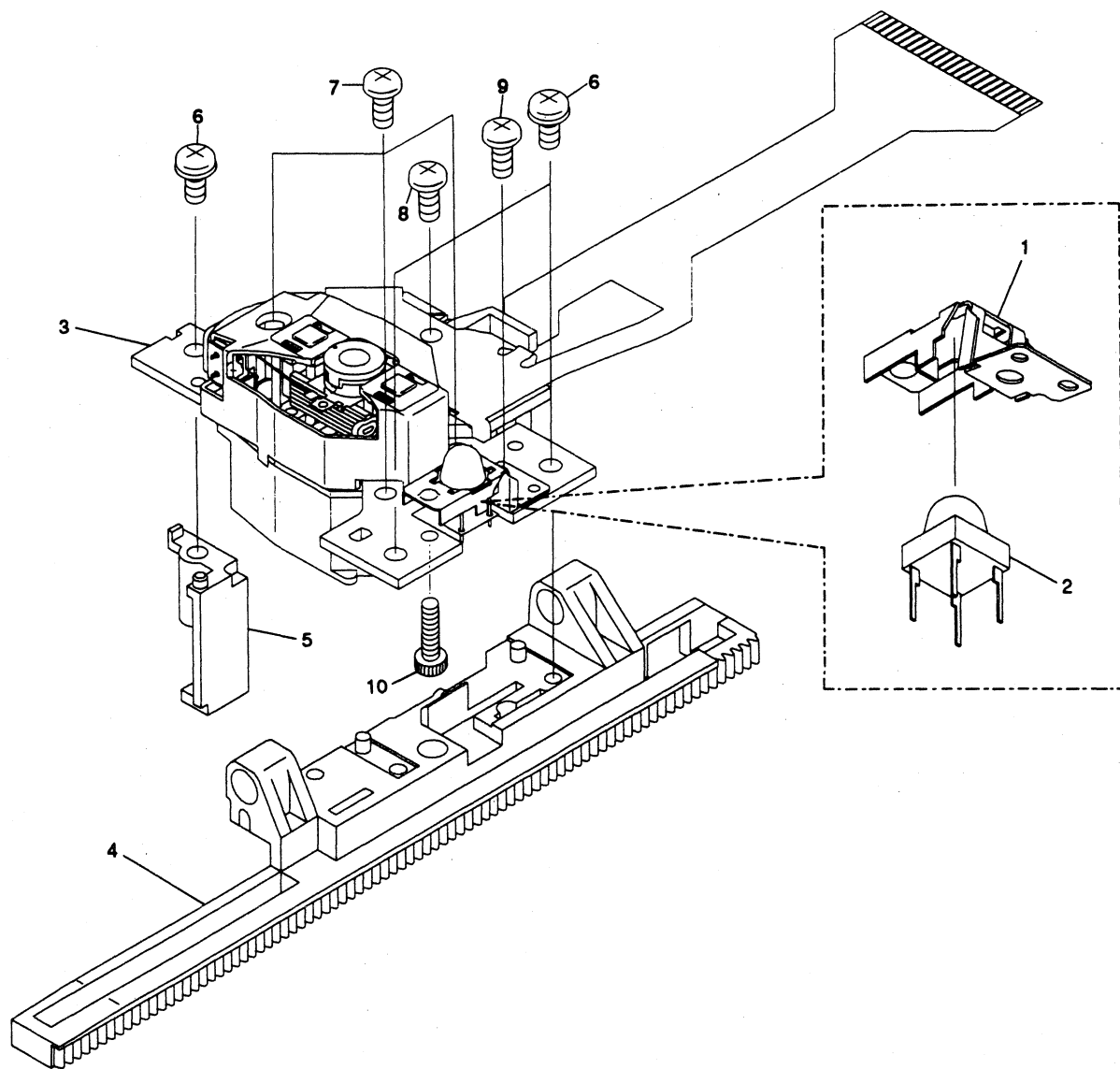

2.2 SCHEMATIC AND PCB CONNECTION DIAGRAMS

NOTE FOR SCHEMATIC DIAGRAMS (Type 4A)

1. When ordering service parts, be sure to refer to "PARTS LIST of EXPLODED VIEWS" or "PCB PARTS LIST".

2. Since these are basic circuits, some parts of them or the values of some components may be changed for improvement.

3. RESISTORS:
Unit: k: kΩ, M: MΩ, or Ω unless otherwise noted.
Rated power: 1/4W, 1/6W, 1/8W, 1/10W unless otherwise noted.
Tolerance: (F): ±1%, (G): ±2%, (K): ±10%, (M): ±20% or ±5% unless otherwise noted.

4. CAPACITORS:
Unit: p: pF or μF unless otherwise noted.
Ratings: capacitor (μF)/ voltage (V) unless otherwise noted.
Rated voltage: 50V except for electrolytic capacitors.

5. COILS:
Unit: m: mH or μH unless otherwise noted.

6. VOLTAGE AND CURRENT:
□ or - V : DC voltage (V) in PLAY mode unless otherwise noted.
◊ mA or - mA : DC current in PLAY mode unless otherwise noted.
Value in () is DC current in STOP mode.

7. OTHERS:
• ⊙ or ⊙ : Adjusting point.
• ◁ : Measurement point.
• The Δ mark found on some component parts indicates the importance of the safety factor of the parts. Therefore, when replacing, be sure to use parts of identical designation.

8. SCH-□ ON THE SCHEMATIC DIAGRAM:
• SCH-□ indicates the drawing number of the schematic diagram. (SCH stands for schematic diagram.)

9. SWITCHES (Underline indicates switch position):

FLKB ASSY	TWKB ASSY
S101 : SURROUND	S701 : 1
S102 : SYSTEM	S702 : 2
S103 : ♪	S703 : 3
S104 : ONE-TOUCH KARAOKE	S704 : 4
S105 : 16 : 9	S705 : 5
S106 : b	S706 : 6
S107 : SCORING	S707 : 7
S108 : #	S708 : 8
S110 : AUDIO MODE	S709 : 9
S112 : ■	S710 : 10
S113 : ▶/	S711 : 11
S114 : ▲CD (OPEN/CLOSE)	S712 : 12
S115 : ▲LD (OPEN/CLOSE)	S713 : 13
	S714 : 14
PONB ASSY	S715 : 15
S201 : NORMAL/KARAOKE/AUX INPUT	S716 : 16
S202 : POWER (STANDBY/ON)	S717 : 17
	S718 : 18
	S719 : 19
	S720 : 20

NOTE FOR PCB DIAGRAMS:

1. Part numbers in PCB diagrams match those in the schematic diagrams.
2. A comparison between the main parts of PCB and schematic diagrams is shown below.

Symbol in PCB Diagrams	Symbol in Schematic Diagrams	Part Name
		Transistor
		Transistor with resistor
		Field effect transistor
		Resistor array
		3-terminal regulator

2.2.1 OVERALL CONNECTIONS, SYPS, FG, PASB, CAMB, LOSB, LOMB AND PICKUP ASSEMBLIES

This diagram is viewed from the mounted parts side.

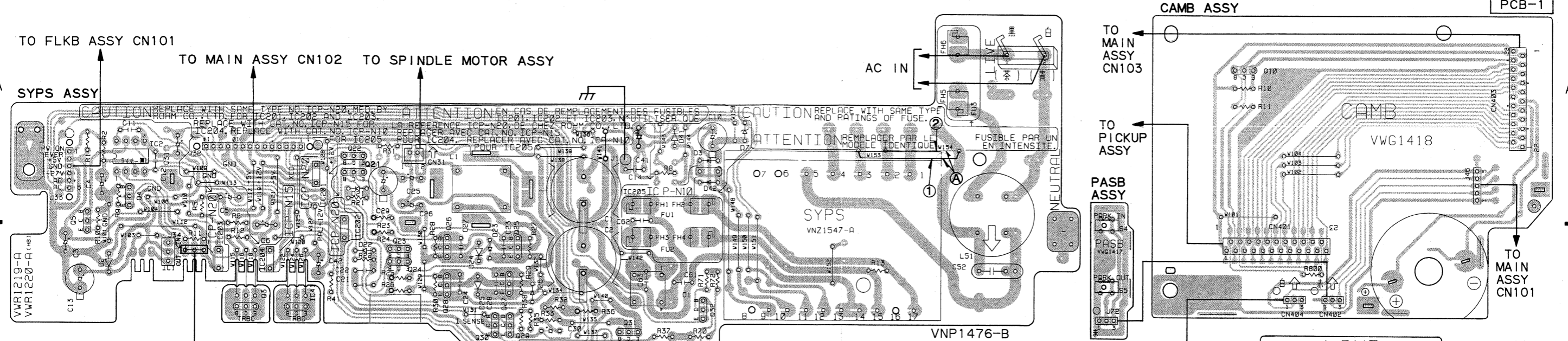

Q5	IC2	IC1	IC203	IC204	IC41	Q22	Q23	Q26	Q27	Q25	Q31	IC205
Q60	Q4	Q61	Q3	IC201	IC202	Q21	Q24	Q28	Q30	Q29		Q32

Line Voltage Selection
 Line Voltage can be changed by the following modification:
 1. Disconnect the AC power cord.
 2. Remove the cover.
 3. Change the position of the jumper-lines @ follows.

Voltage	jumper-line @ position
220V-230V	①
240V	②

NOTE: When replacing a PCB which has the primary winding circuit of Power-transformer, be sure to compare its circuit with the diagram in Service Manual. Jumper-lines on the PCB may have to be removed. Forgetting this check-up will cause a serious damage.

4. Stick a line voltage label on the rear panel.

Part No.	Description
AAX-193	220V label
AAX-192	240V label

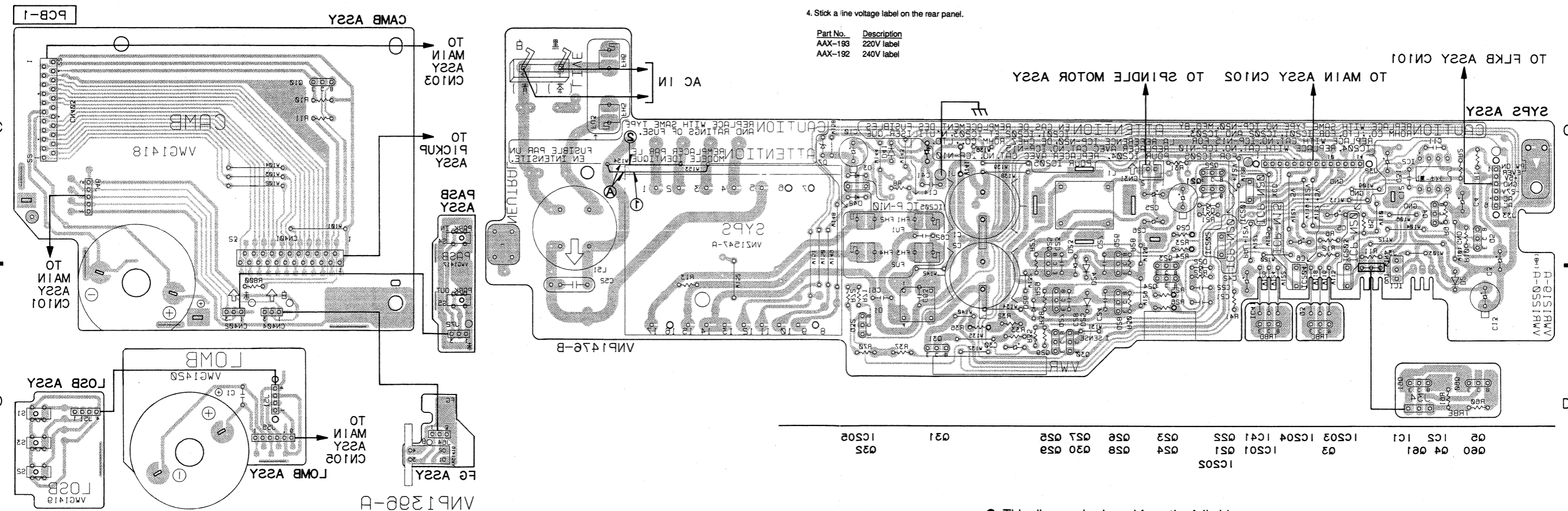

This diagram is viewed from the foil side.

FRPB ASSY
(VMM1521)
(→SCH-2)

(TWKB ASSY: VWG1551)
(PONB ASSY: VWG1552)
(FLKB ASSY: VWG1567)
(JACB ASSY: VVW1396)

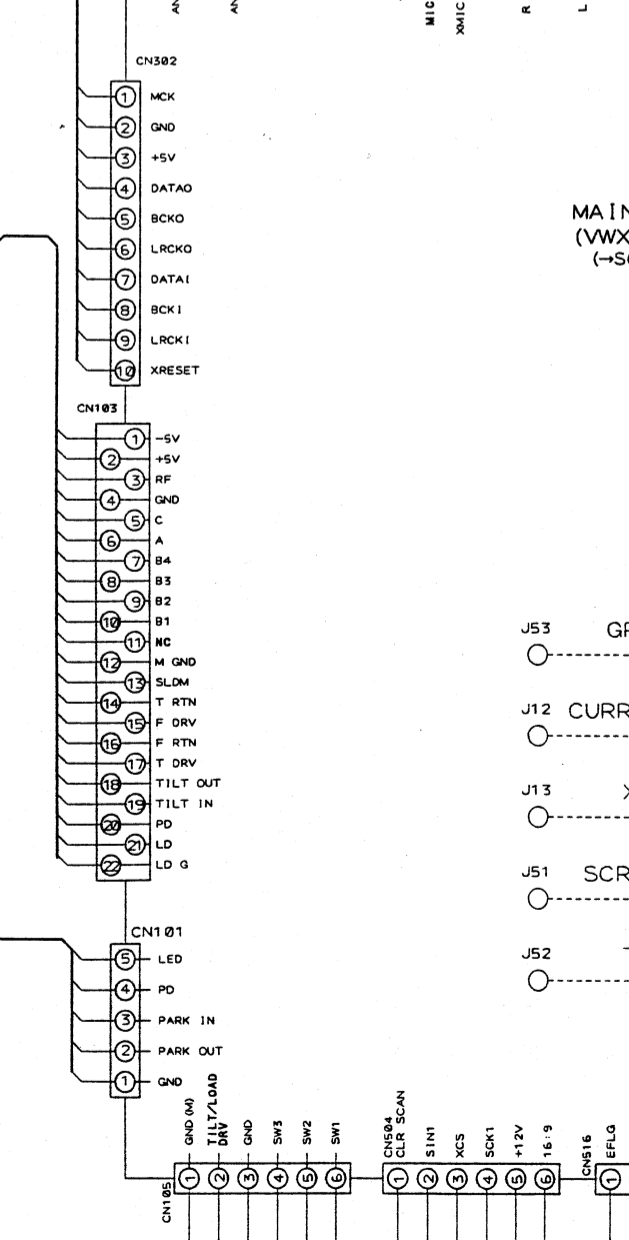
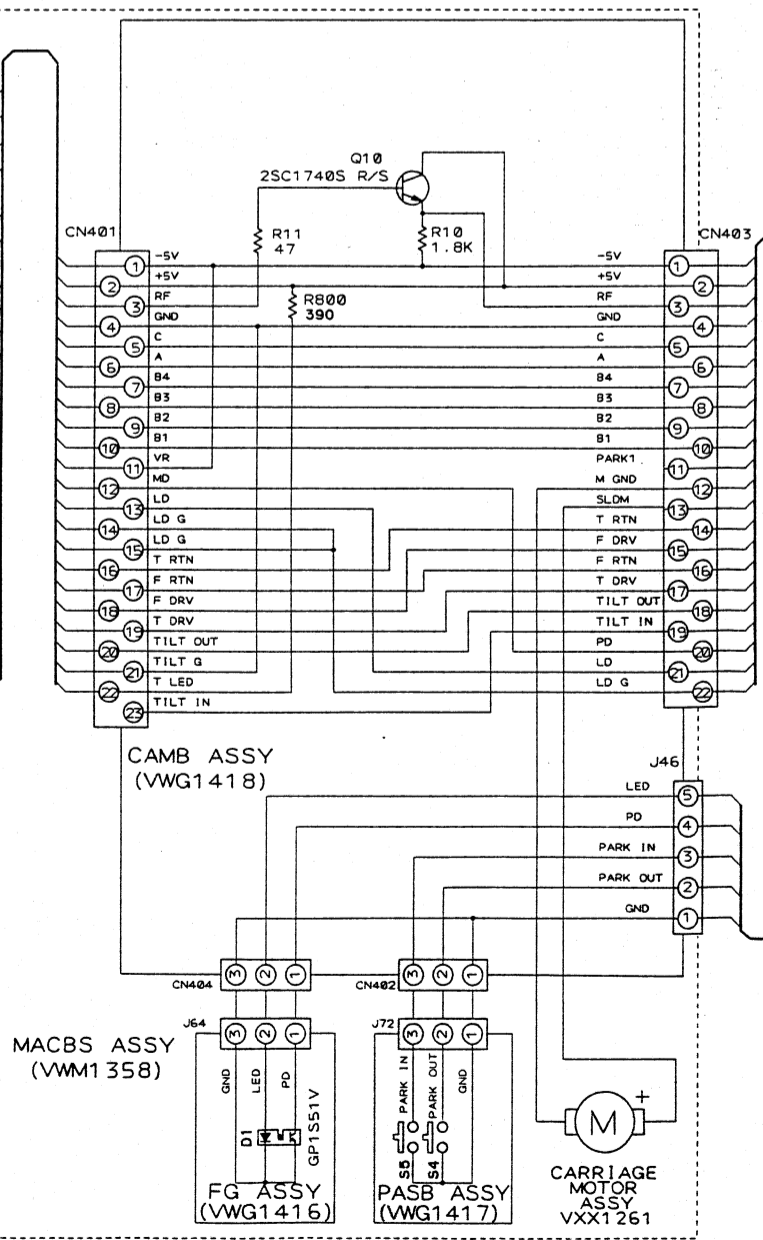
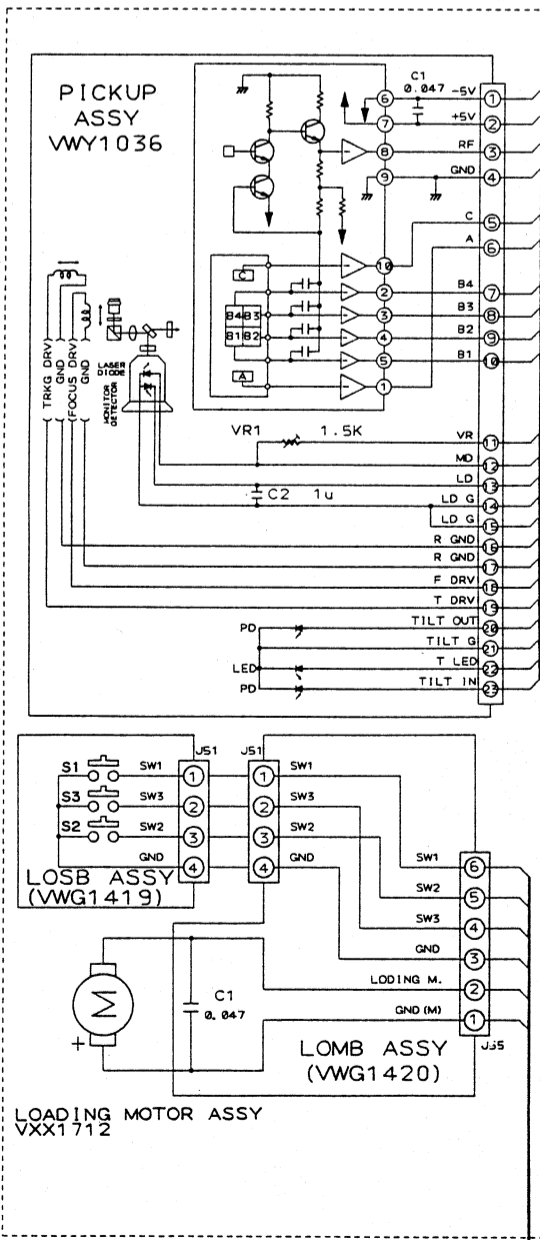
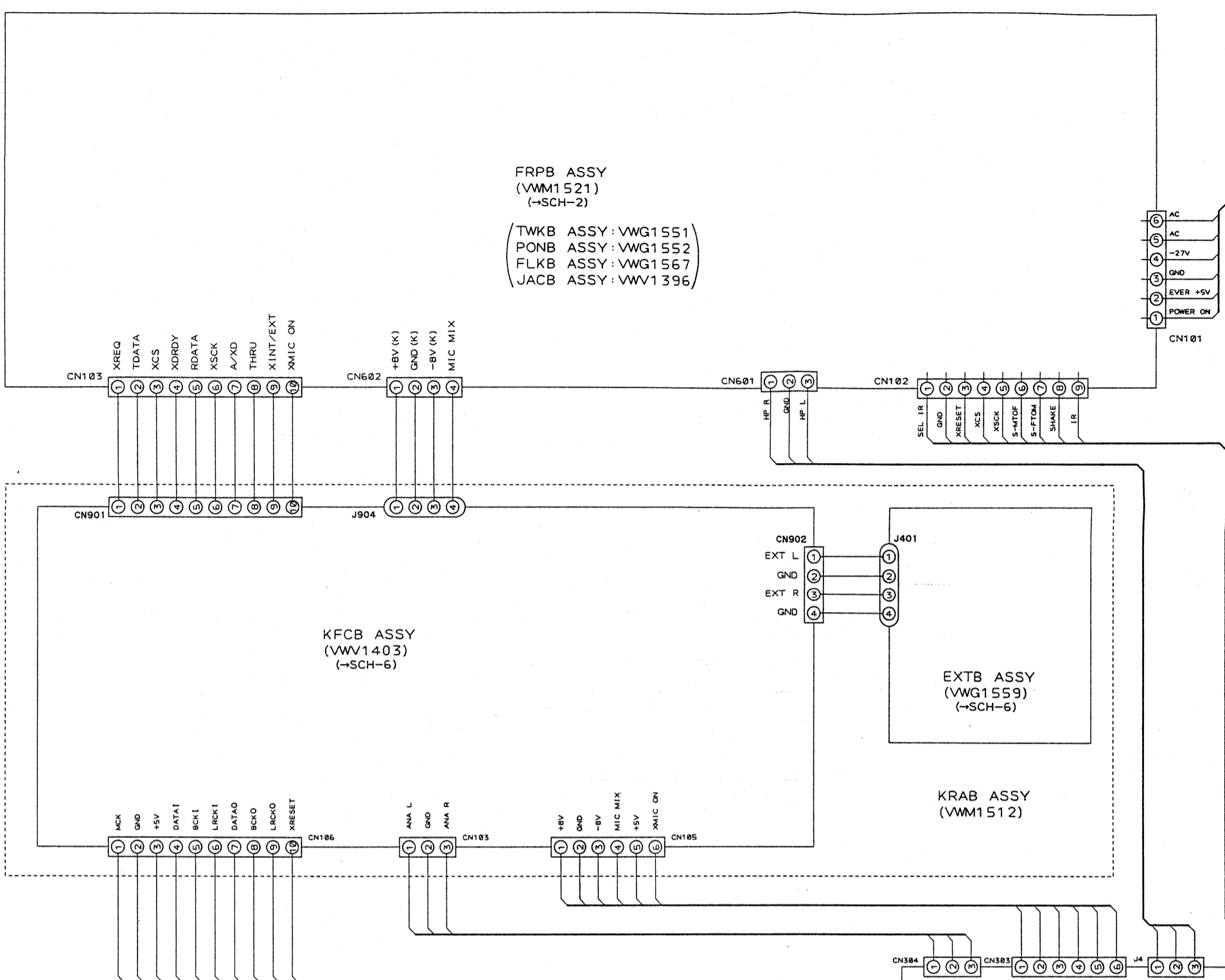

SCH-1

OVERALL CONNECTIONS,
SYPS ASSY, FG ASSY, PASB ASSY,
CAMB ASSY, LOSB ASSY,
LOMB ASSY, PICKUP ASSY

CAUTION: FOR CONTINUED PROTECTION AGAINST RISK OF FIRE, REPLACE WITH SAME TYPE NO. ICP-N10, MFD BY ROHM CO., LTD. FOR IC205.

CAUTION: FOR CONTINUED PROTECTION AGAINST RISK OF FIRE, REPLACE WITH SAME TYPE NO. ICP-N20, MFD BY ROHM CO., LTD. FOR IC201-IC203.

CAUTION: FOR CONTINUED PROTECTION AGAINST RISK OF FIRE, REPLACE WITH SAME TYPE NO. ICP-N15, MFD BY ROHM CO., LTD. FOR IC204.

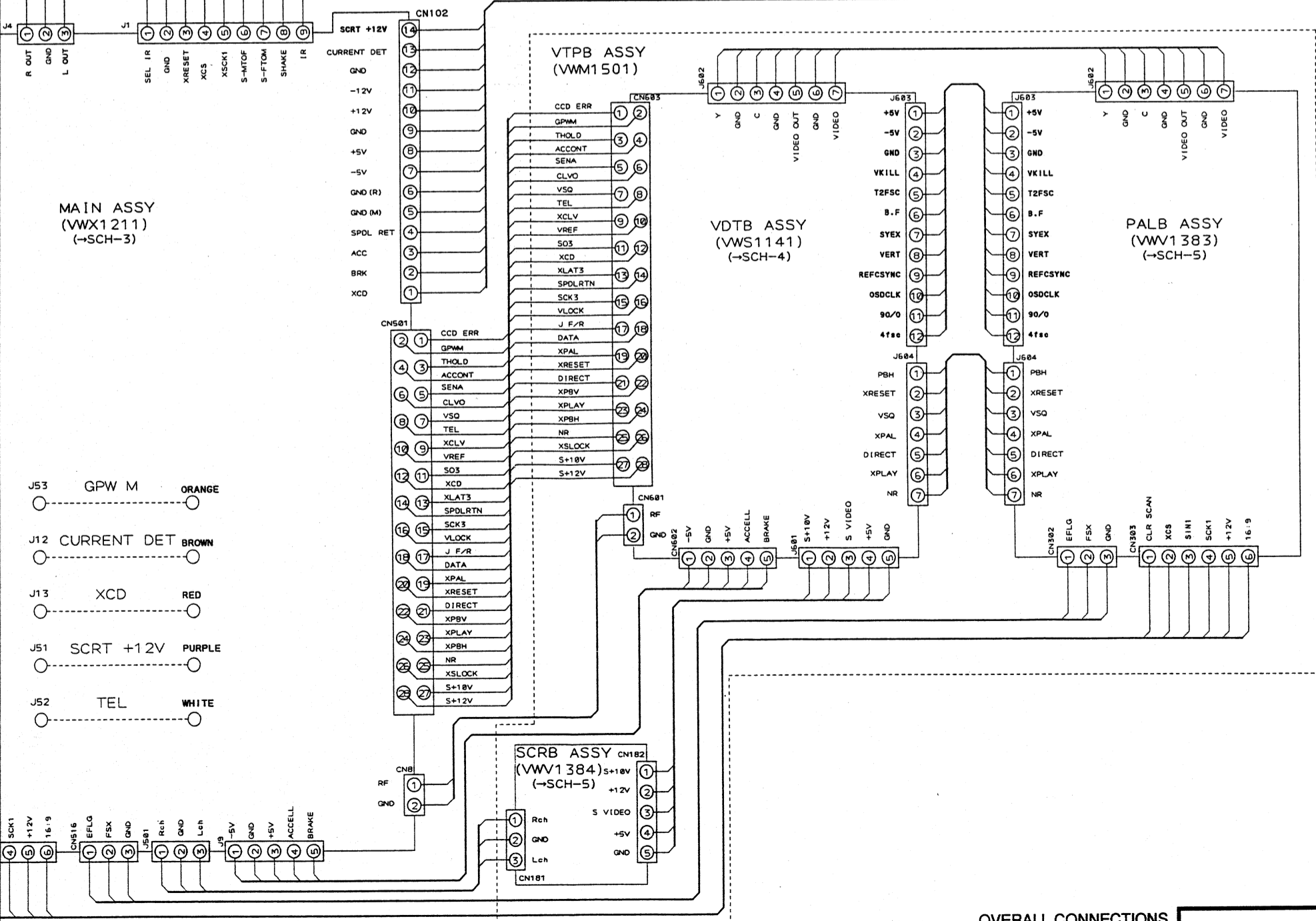
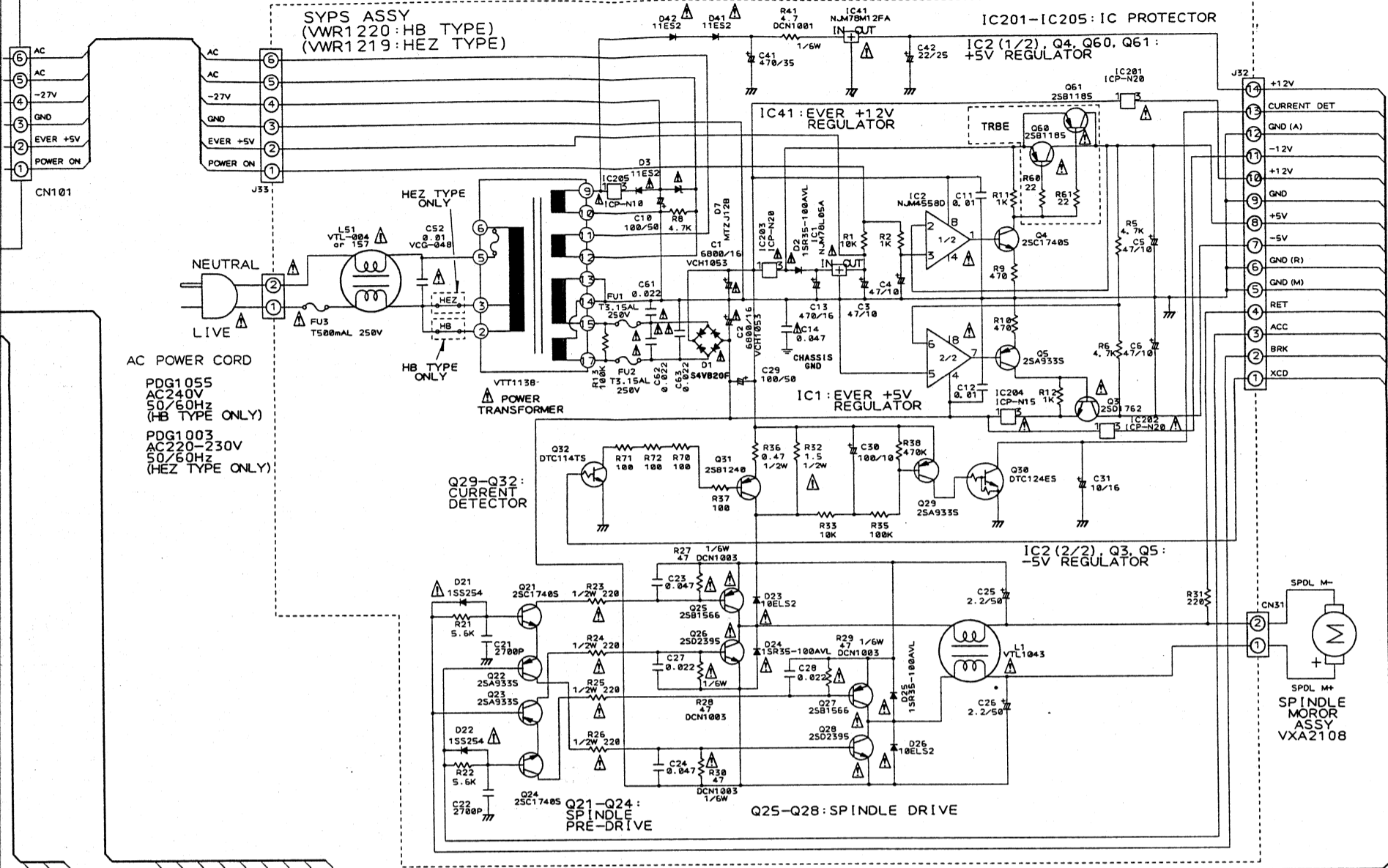

OVERALL CONNECTIONS, SYPS ASSY, FG ASSY, PASB ASSY, CAMB ASSY, LOSB ASSY, LOMB ASSY, PICKUP ASSY

2.2.2 FLKB, JACB, TWKB AND PONB ASSEMBLIES

FLKB ASSY
VWG1567

TWKB ASSY
VWG1551

	KIN0	KIN1	KIN2	KIN3	KIN4	KIN5
KS0		SCORING	CD	LD	AUDIO	#
KS1	16+9	SURROUND	b	h	ONE-TOUCH KARAOKE	SYSTEM
KS2	5	PLAY/PAUSE	4	2	3	1
KS3	6	STOP	10	8	9	7
KS4	15		11	13	14	12
KS5	19		16	17	18	20

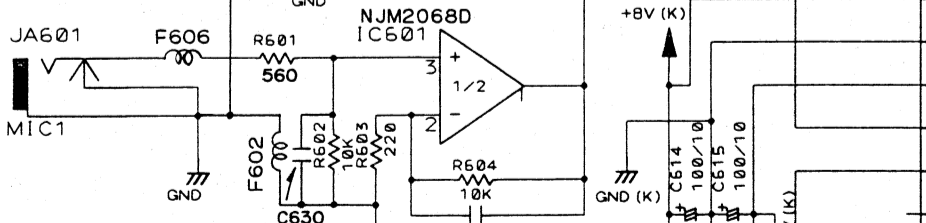
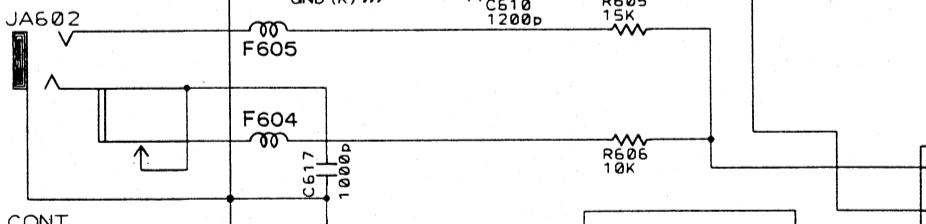
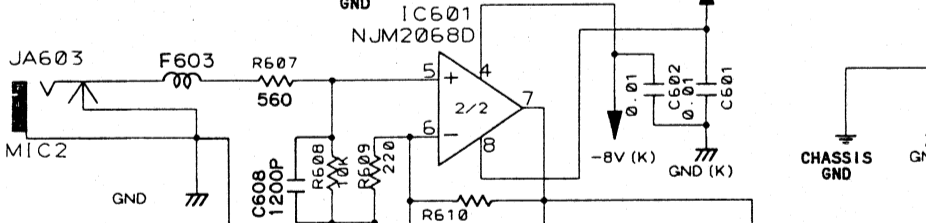
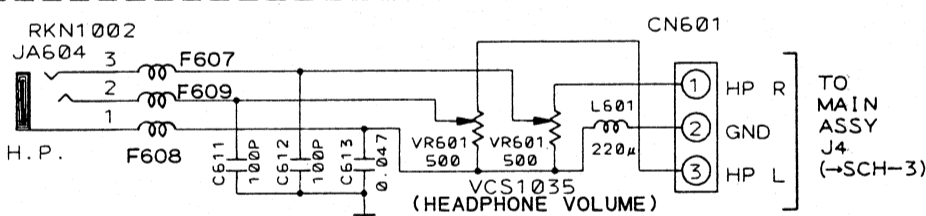

JACB ASSY
VWV1396

F602-609:VTH1016
JA601, 603:VKN1147
JA602:RKN1005

TO KFCB ASSY J904 (-SCH-6)

TO MAIN ASSY J1 (-SCH-3)

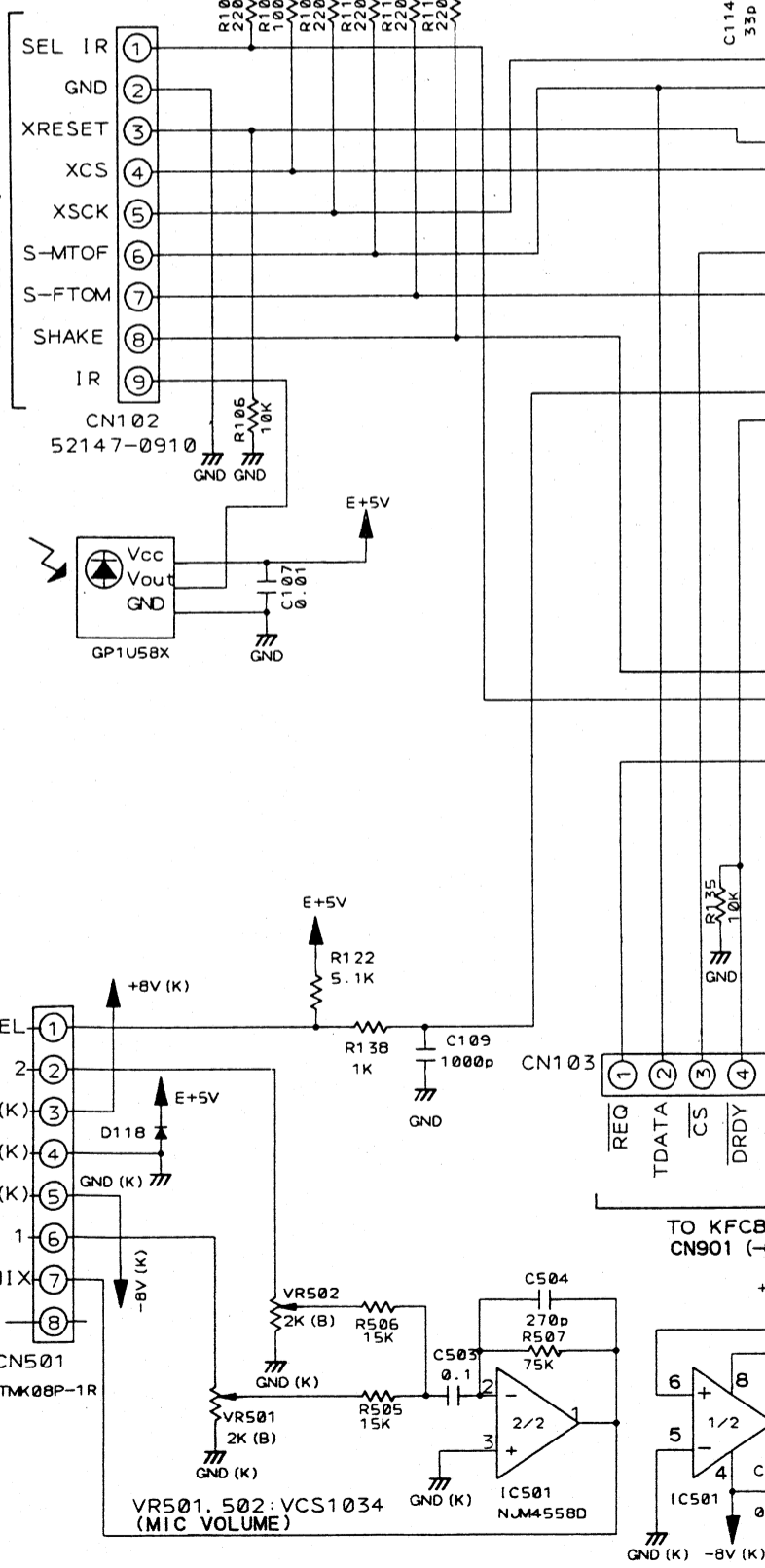

SCH-2

FLKB ASSY, JACB ASSY,
TWKB ASSY, PONB ASSY

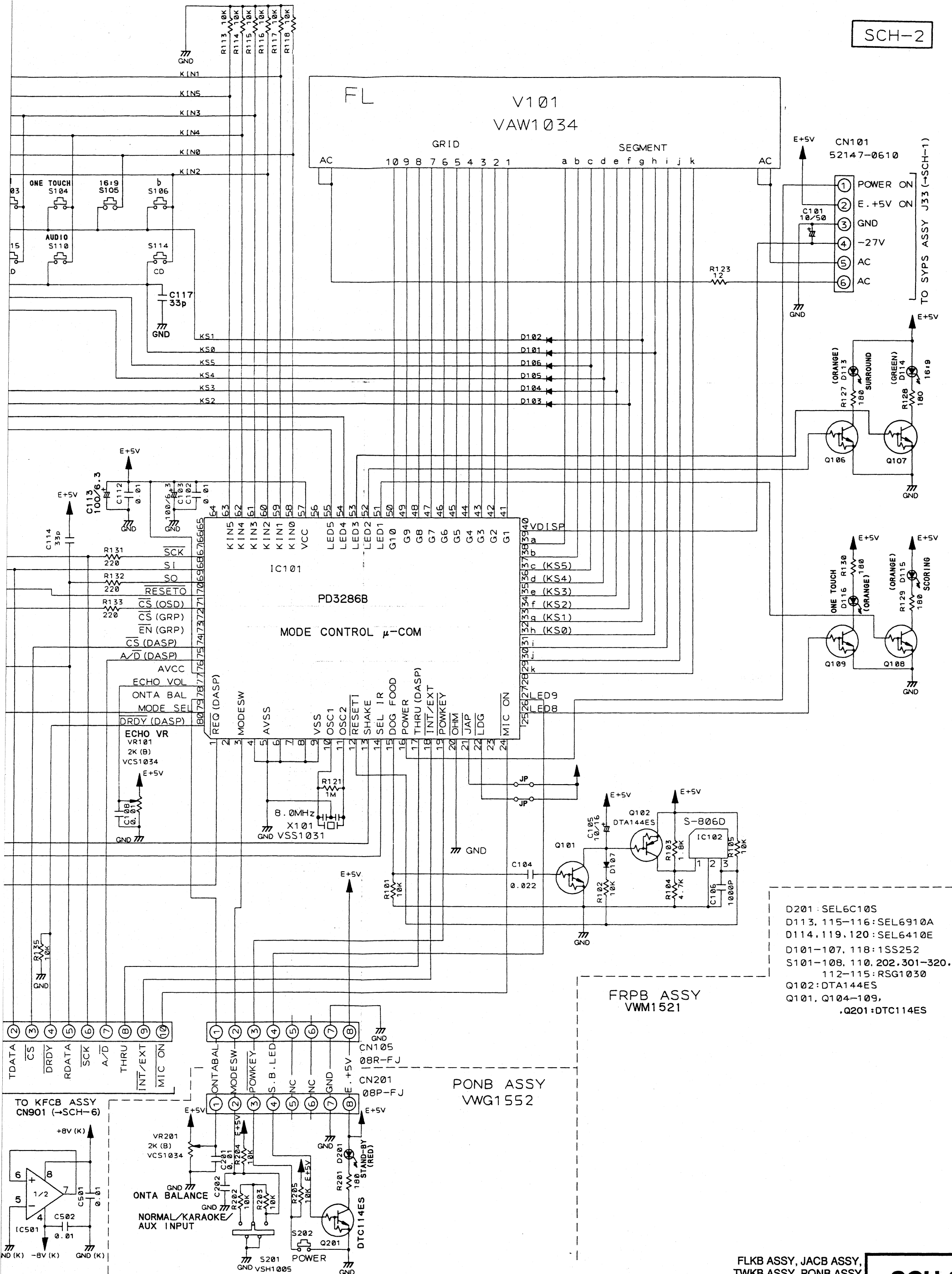

- D201: SEL6C10S
- D113, 115-116: SEL6910A
- D114, 119, 120: SEL6410E
- D101-107, 118: 1SS252
- S101-108, 110, 202, 301-320, 112-115: RSG1030
- Q102: DTA144ES
- Q101, Q104-109, Q201: DTC114ES

This dia

TWKB ASSY

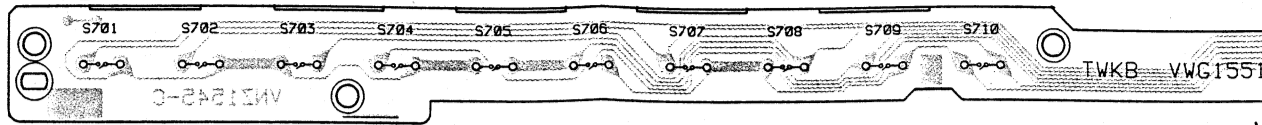

PONB ASSY

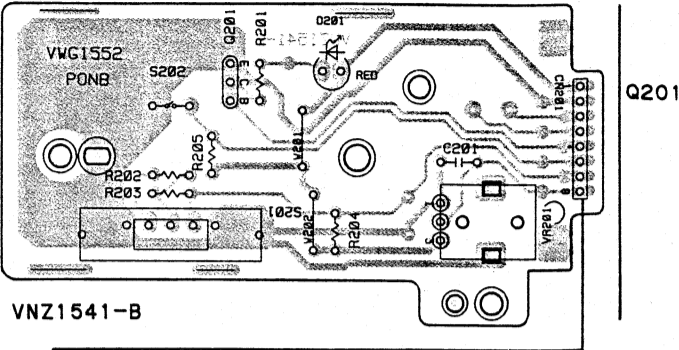

VNZ1541-B

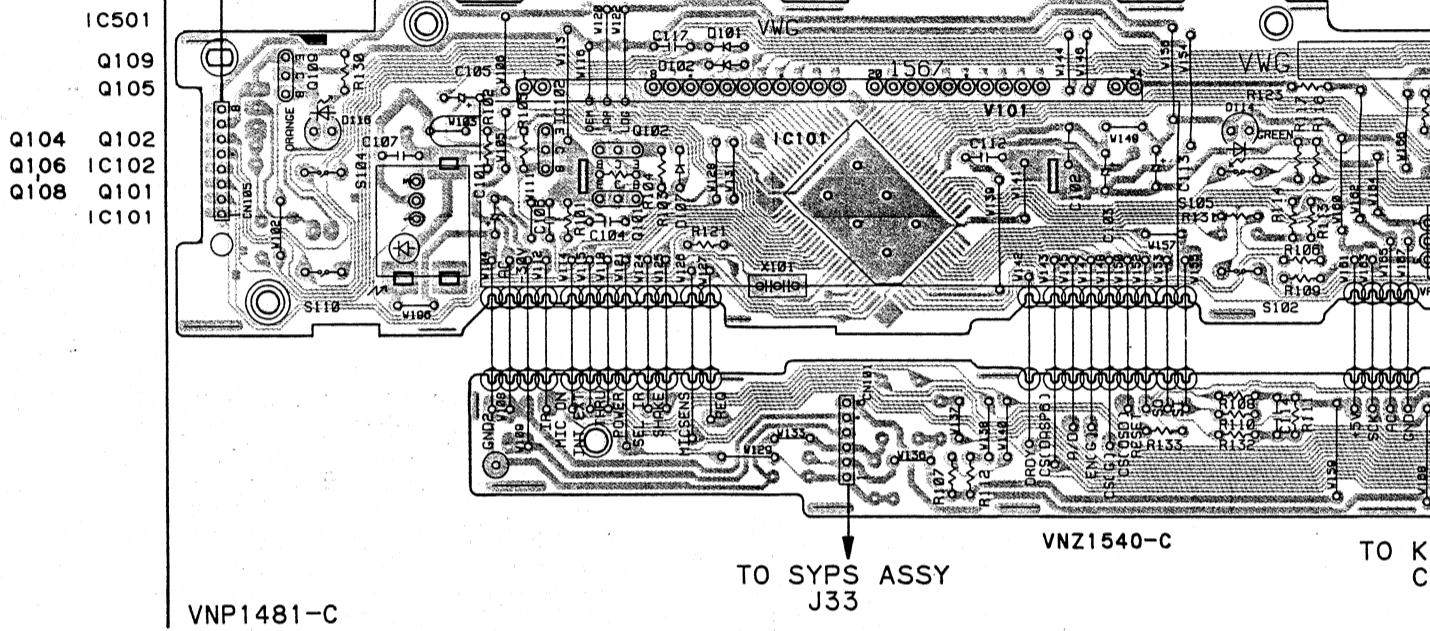

This dia

PCB-5

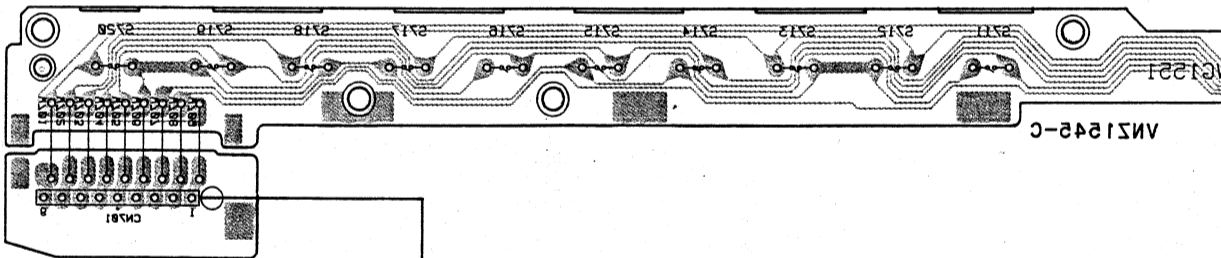

FLKB ASSY

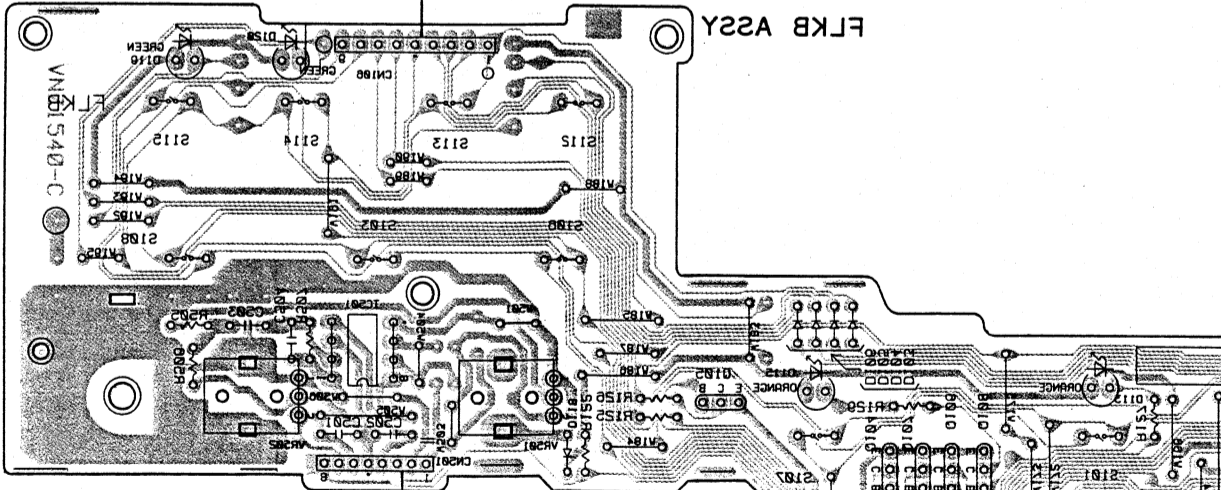

TO MAIN ASSY J4

JACB ASSY

TO KCB ASSY J304

TO MAIN ASSY J1

TO KCB ASSY CNA01

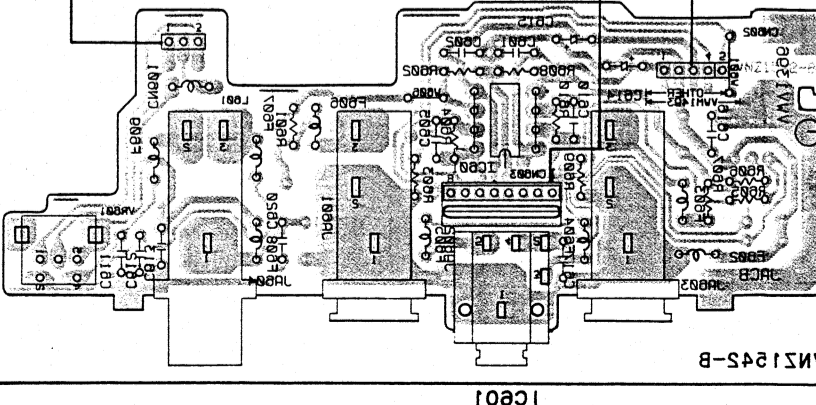

VNZ145-B

IC901

This dia

● This diagram is viewed from the mounted parts side.

PCB-2

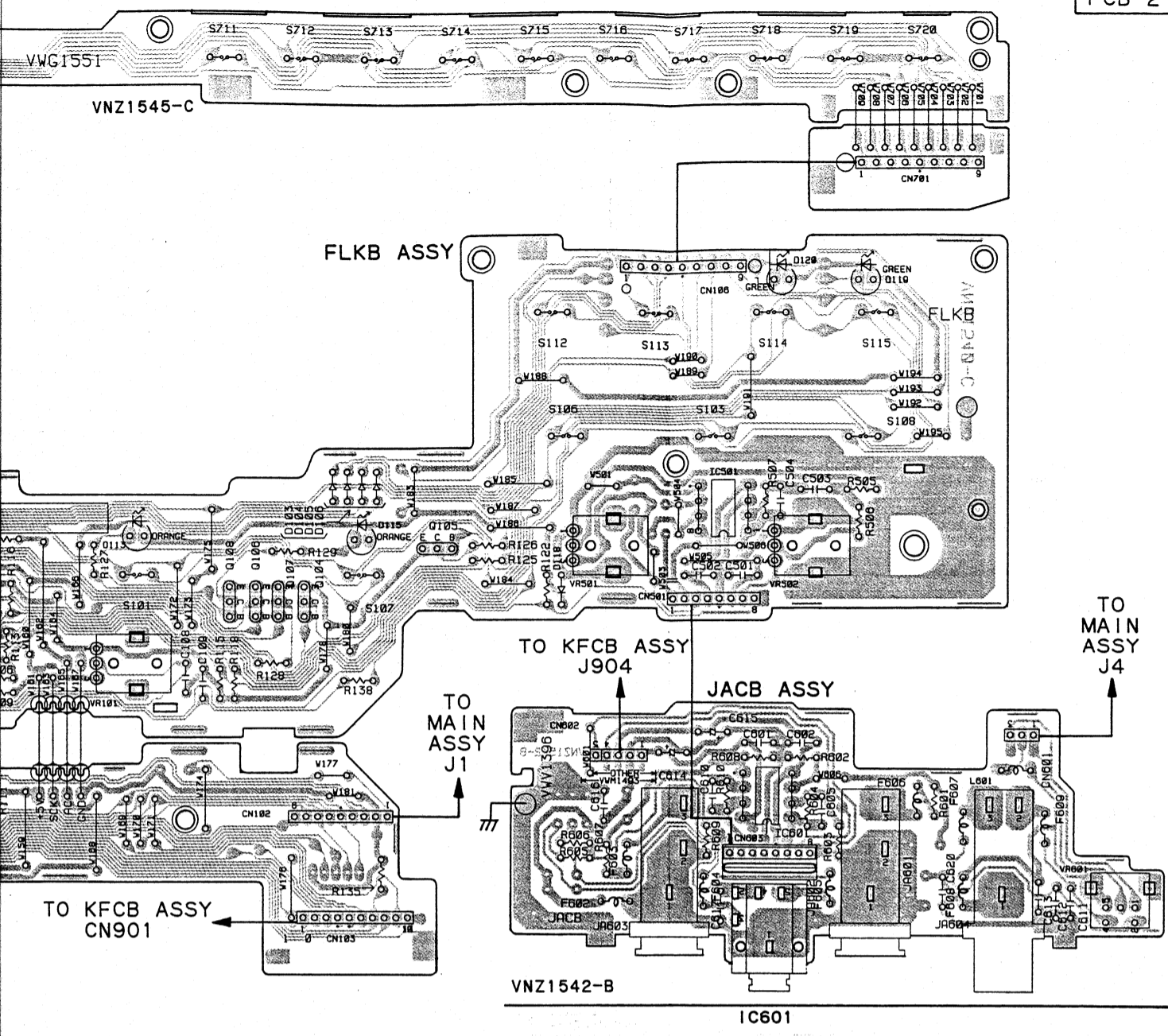

● This diagram is viewed from the foil side.

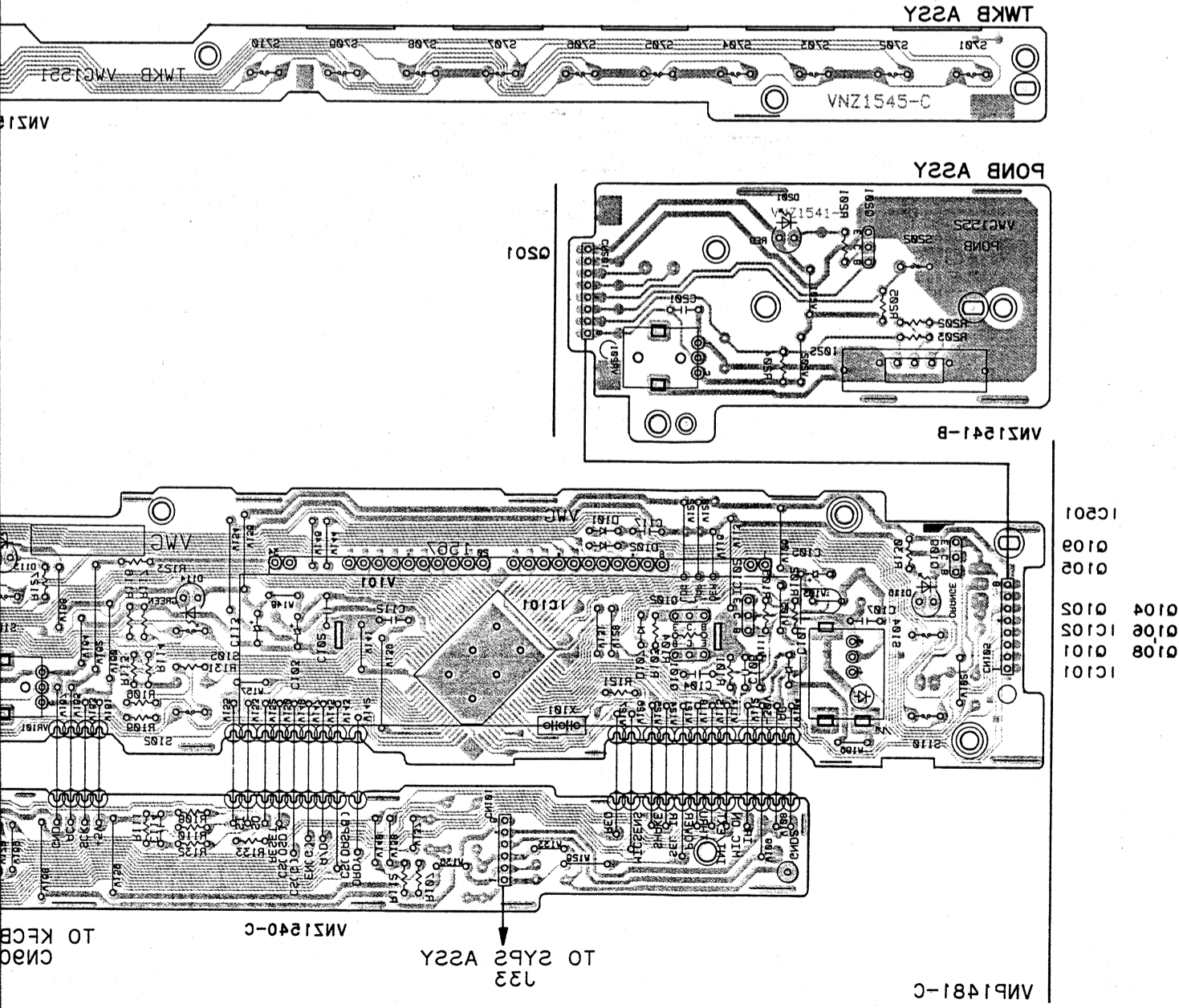

- IC201
- Q102
- Q103
- Q104
- Q105
- Q106
- Q107
- Q108
- Q109
- Q110

A
B
C
D
E
F

2.2.3 MAIN ASSEMBLY

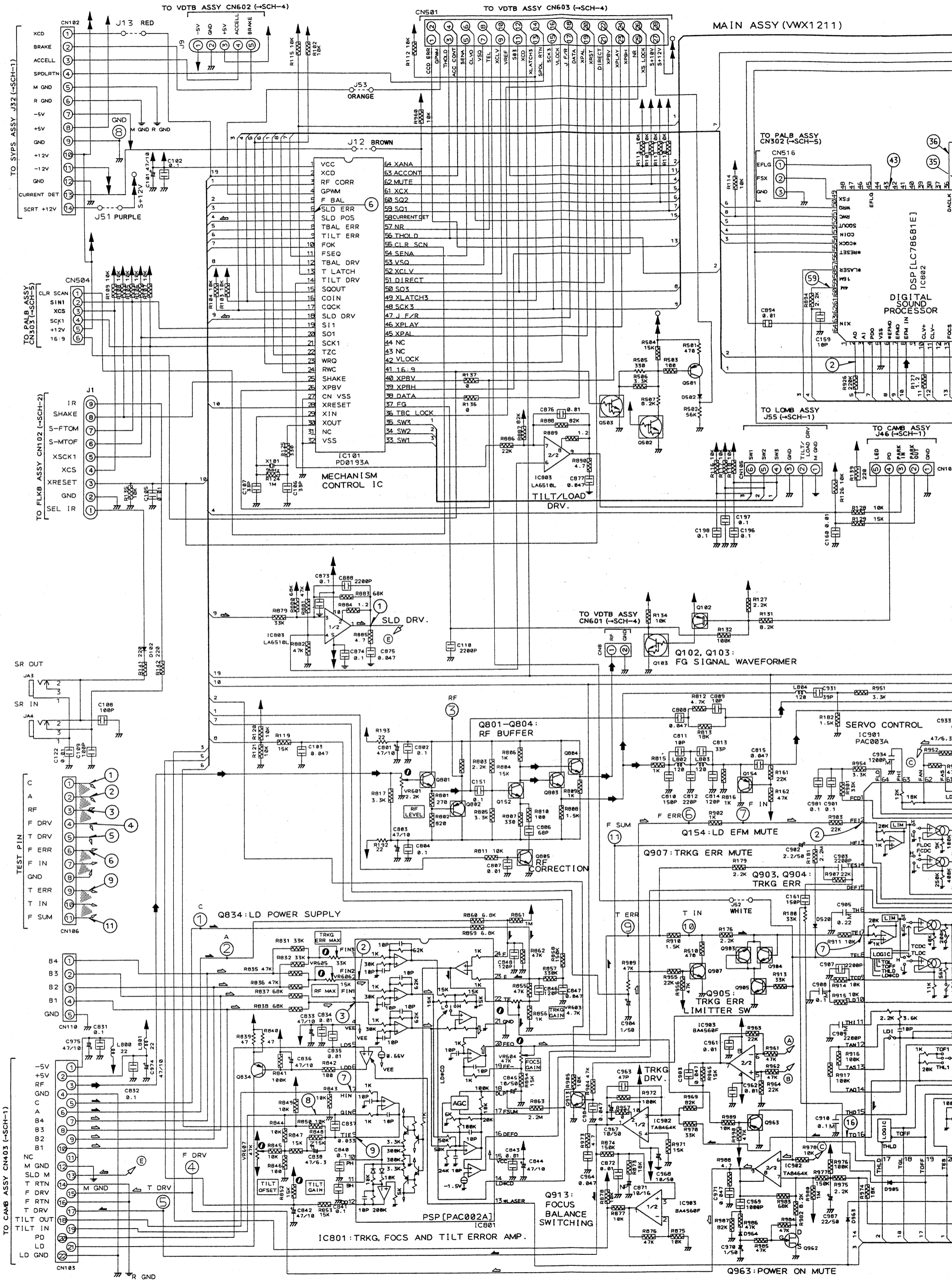

SCH-3

MAIN ASSY

SCH-3

- ◆ RF SIGNAL LINE
- ▲ TRKG SERVO LOOP LINE
- ▷ FOCSS SERVO LOOP LINE
- ◁ SLDR SERVO LOOP LINE
- ◇ AUDIO SIGNAL LINE

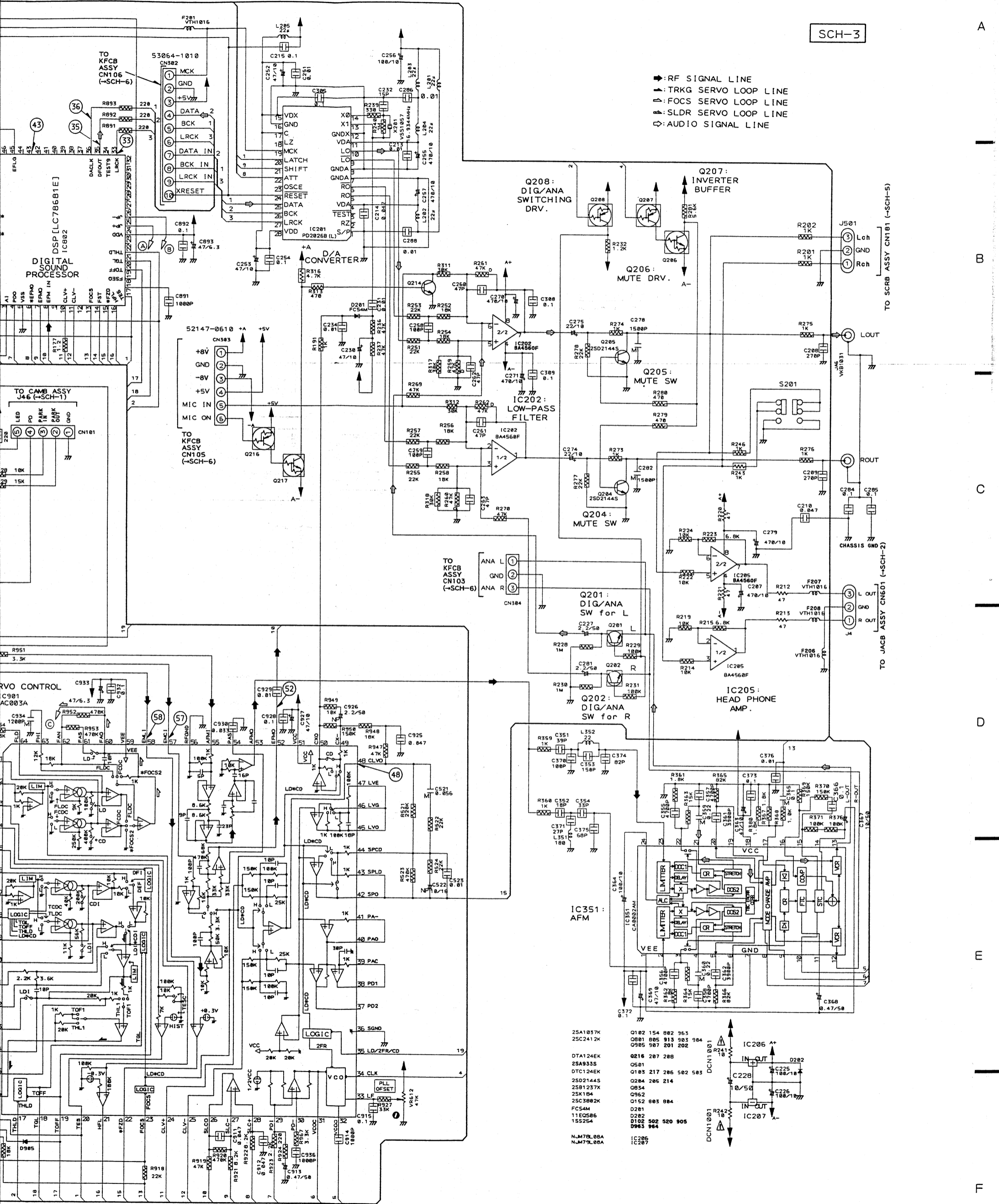

- 25A1057K
- 25C2412K
- DTA124EK
- 25A9335
- DT124EK
- 25D2144S
- 25B1237X
- 25K104
- 25C2802K
- FCS4M
- 11EQ586
- 15S254
- NJM78L08A
- NJM79L08A

- Q102 154 002 965
- Q801 805 913 903 904
- Q905 907 201 202
- Q216 207 208
- O501
- O103 217 206 502 503
- O204 205 214
- O834
- O962
- O152 003 004
- O202
- O102 502 520 905
- O963 964
- IC206
- IC207

MAIN ASSY

SCH-3

MAIN ASSEMBLY

Note: (No) in the table correspond to the pin number.

Measurement condition: In case when (D.audio) is written, at time when disc that has digital audio recording is played.

IC801(PAC002A)	IC802(LC78681E)	IC803(LA6510L)	IC901(PAC003A)	CN106	IC101 (PD0193A)
②, ③ 1mS/Div. 16mVp-p AC mode	② 0.1μS/Div. 4.3Vp-p AC mode(D.audio)	① 2mS/Div. 1.8Vp-p DC mode	② 0.2mS/Div. 74mVp-p DC mode	①, ② 5mS/Div. 65mVp-p DC mode	⑥ 1V/Div 5mS/Div approx. 1.8V DC mode (Slr err)
⑦, ⑧ 1mS/Div. 67mVp-p DC mode	③③ 10μS/Div. 4.2Vp-p AC mode(D.audio)		⑦ 0.2mS/Div. 74mVp-p DC mode	③ 0.5mS/Div. 300mVp-p AC mode	
⑨ 5mS/Div. 0.1Vp-p DC mode	③⑤ 0.2μS/Div. 4.4Vp-p AC mode(D.audio)		⑩ 0.2μS/Div. 0.61Vp-p DC mode	④ 5mS/Div. 15Vp-p DC mode	
	③⑥ 0.2μS/Div. 4.5Vp-p AC mode(D.audio)		④⑧ 50μS/Div. 6.2Vp-p DC mode	⑤ 5mS/Div. 5.8Vp-p DC mode	
	④③ 0.1μS/Div. 4.5Vp-p AC mode(D.audio)		⑤② 0.2μS/Div. 2.1Vp-p AC mode	⑥ 5mS/Div. 3.5Vp-p DC mode	
	⑤⑨ 0.1μS/Div. 2Vp-p AC mode(D.audio)		⑤⑦ 1mS/Div. 0.53Vp-p DC mode	⑨ 5mS/Div. 1.25Vp-p DC mode	
			⑤⑧ 0.2mS/Div. 0.32Vp-p DC mode	⑪ 10mS/Div. 1.7Vp-p DC mode	

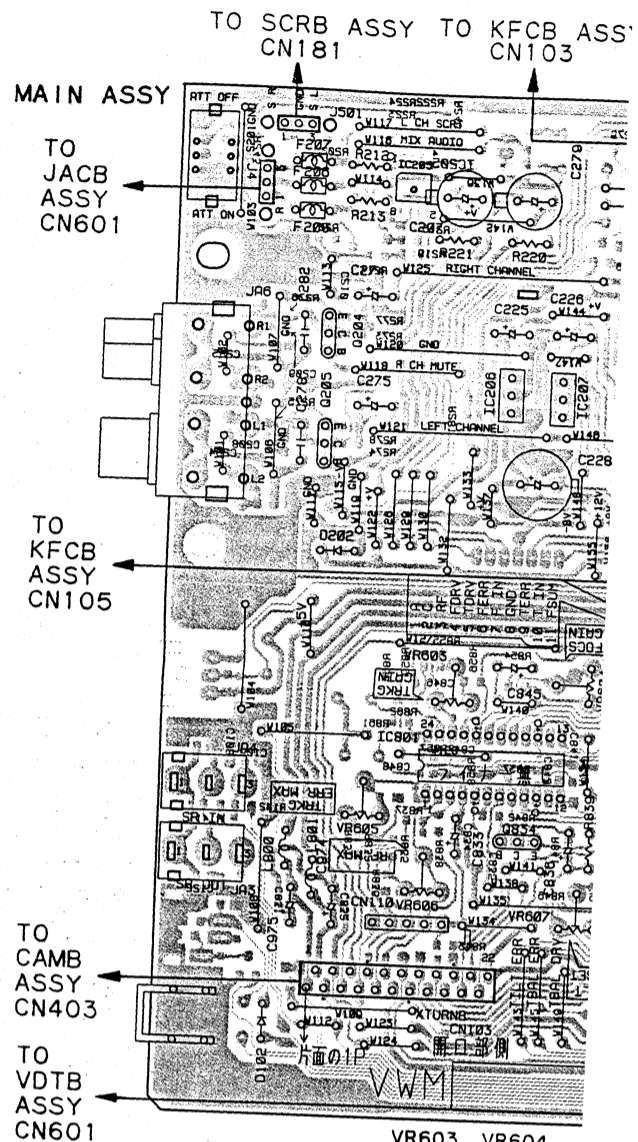

VR603 VR604
VR605 VR606 VR607
Q204 IC206 IC207
Q205 IC801 Q834
IC802

PCB-3

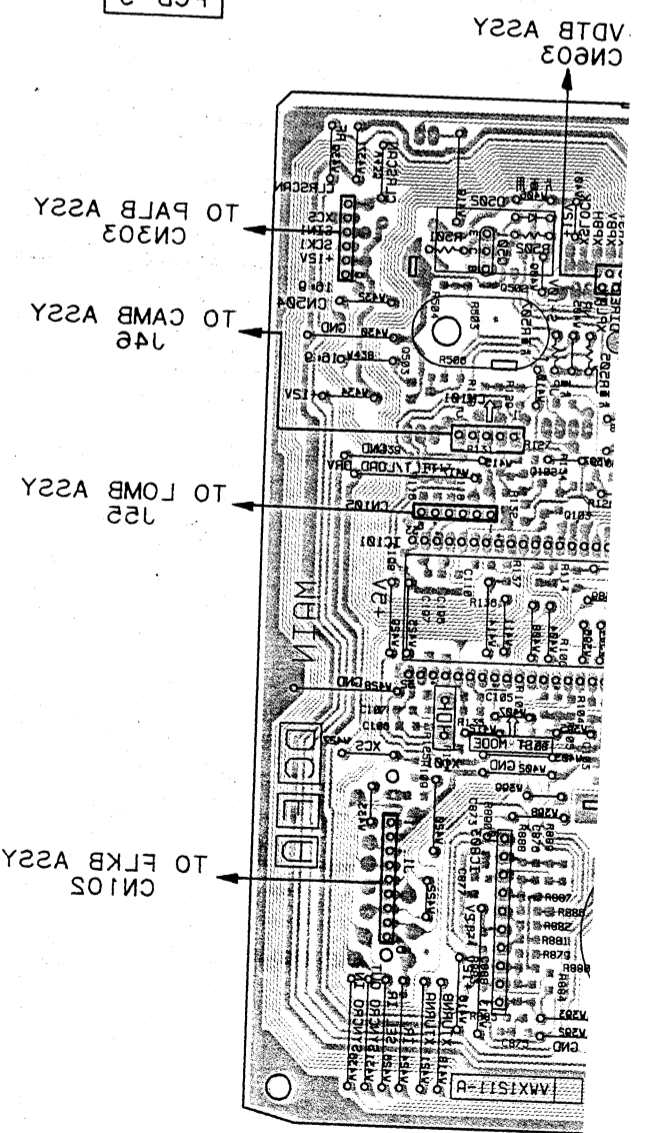

Q503 IC803 Q201
Q502
Q102
Q103

A

B

C

D

E

F

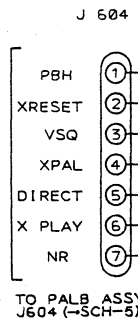
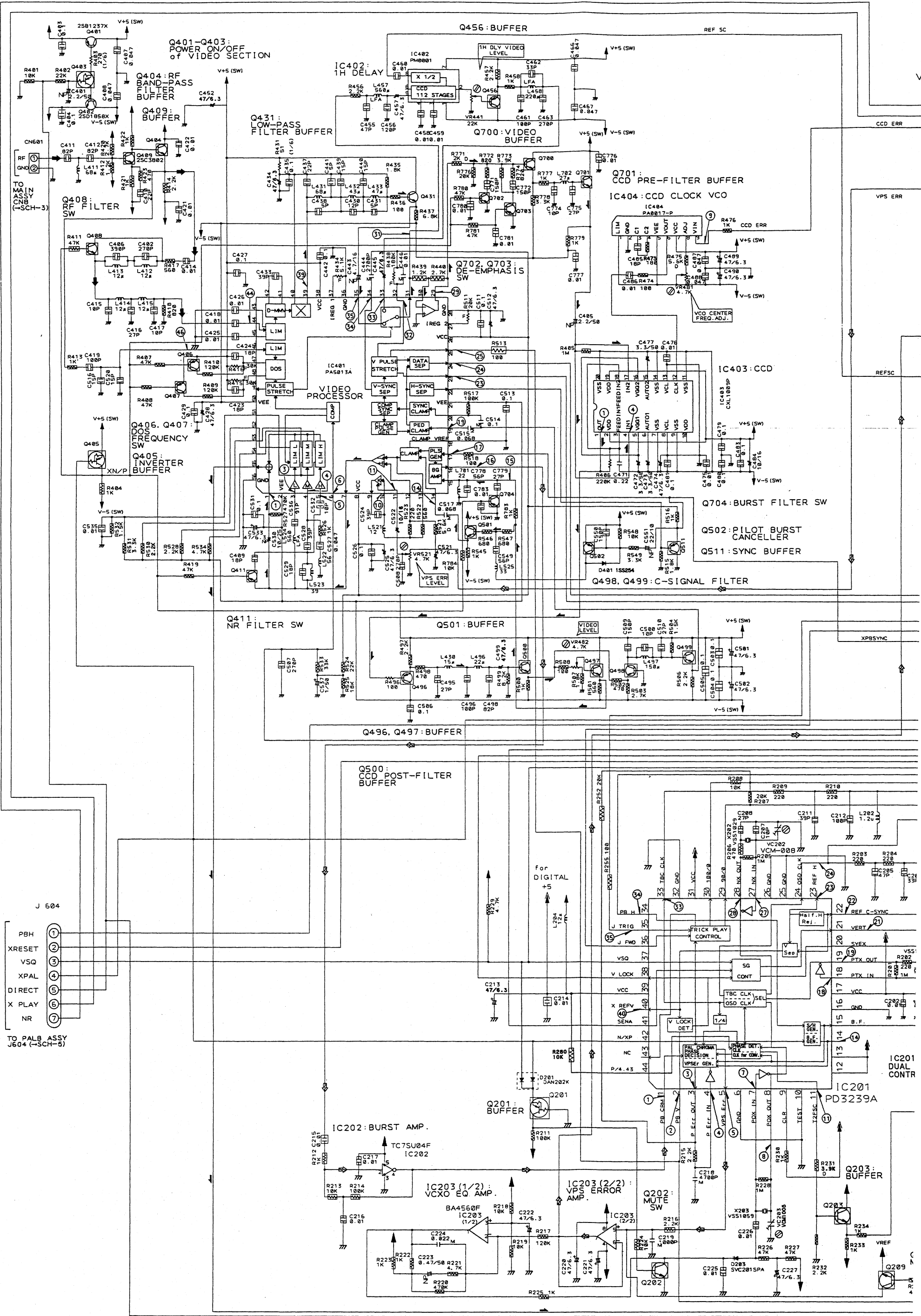

SCH-4

VDTB ASSY

VDTB ASSY (VWS1141)

DTA124EK	Q201	403	405	606	609	621	622	623				
25C2412K	Q202	203	205	206	209	404	408	497	498			
	Q499	500	501	601	602	603	604	605	608	700	701	702
25A1037K	Q204	207	406	407	411	456	496	502	511	703	704	
25B1237X	Q401											
25D1858X	Q402											
25C3802K	Q409											
25C1740S	Q431											
DTC124EK	Q607	610	612	613	624	625						

- ▶: RF SIGNAL LINE
- ▲: VIDEO SIGNAL LINE
- ⊞: SPINDLE SERVO LOOP LINE

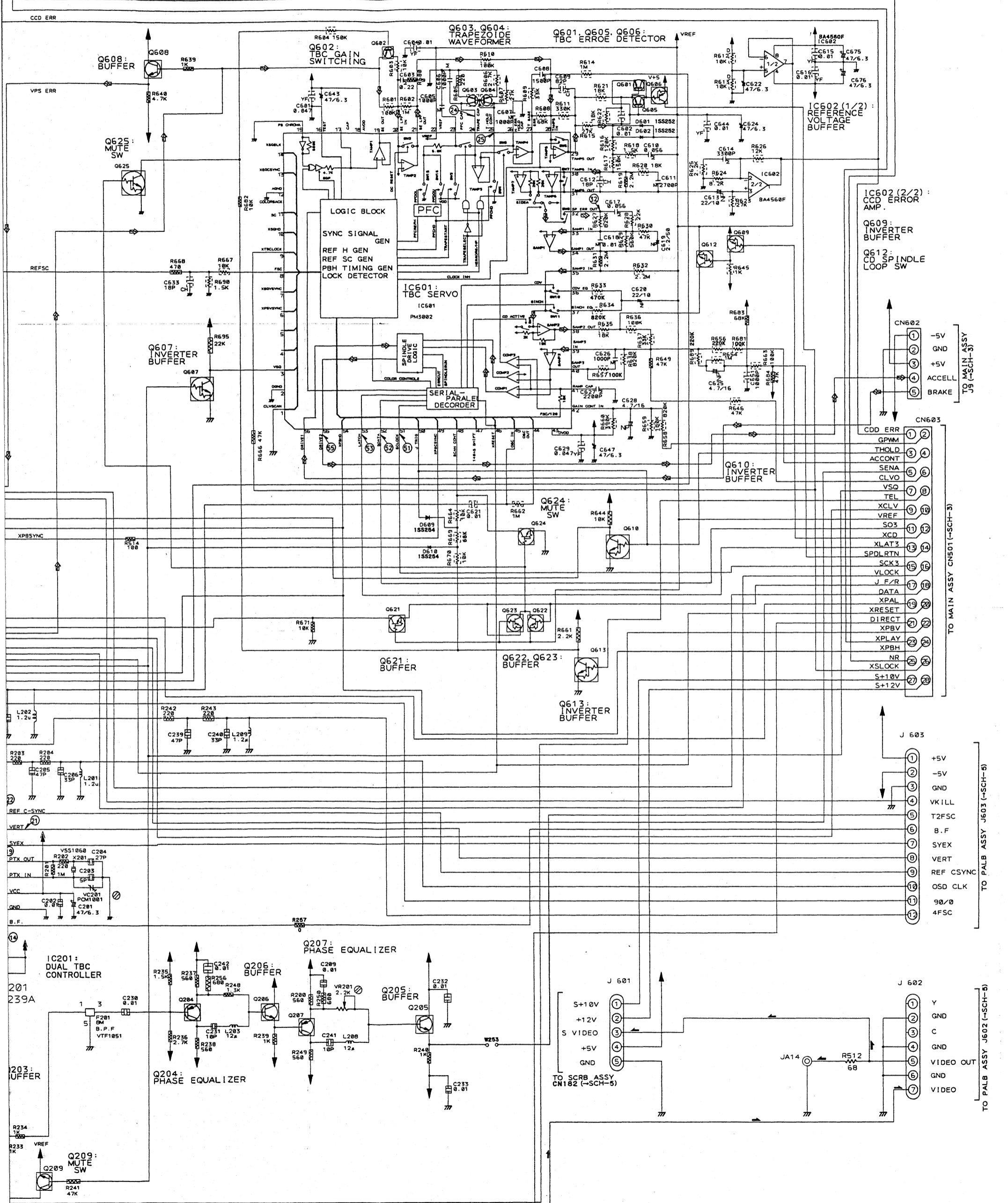

- CN602
- 1 -5V
 - 2 GND
 - 3 +5V
 - 4 ACCELL
 - 5 BRAKE
- TO MAIN ASSY J9 (-SCH-3)

- CN603
- 1 CDD ERR
 - 2 GPWM
 - 3 THOLD
 - 4 ACCONT
 - 5 SENA
 - 6 CLVO
 - 7 VSO
 - 8 TEL
 - 9 XCLV
 - 10 VREF
 - 11 SO3
 - 12 XCD
 - 13 XLAT3
 - 14 SPDL RTN
 - 15 SCK3
 - 16 VLOCK
 - 17 J F/R
 - 18 DATA
 - 19 XPAL
 - 20 XRESET
 - 21 DIRECT
 - 22 XPBV
 - 23 XPLAY
 - 24 XPBH
 - 25 NR
 - 26 XSLOCK
 - 27 S+10V
 - 28 S+12V
- TO MAIN ASSY CNS01 (-SCH-3)

- J 603
- 1 +5V
 - 2 -5V
 - 3 GND
 - 4 VKILL
 - 5 T2FSC
 - 6 B.F
 - 7 SYEX
 - 8 VERT
 - 9 REF CSYNC
 - 10 OSD CLK
 - 11 90/0
 - 12 4FSC
- TO PALB ASSY J603 (-SCH-5)

- J 601
- 1 S+10V
 - 2 +12V
 - 3 S VIDEO
 - 4 +5V
 - 5 GND
- TO SCRIB ASSY CN182 (-SCH-5)

- J 602
- 1 Y
 - 2 GND
 - 3 C
 - 4 GND
 - 5 VIDEO OUT
 - 6 GND
 - 7 VIDEO
- TO PALB ASSY J602 (-SCH-5)

VDTB ASSY

VDTB ASSEMBLY

Note: (No.) in the table correspond to the pin number.

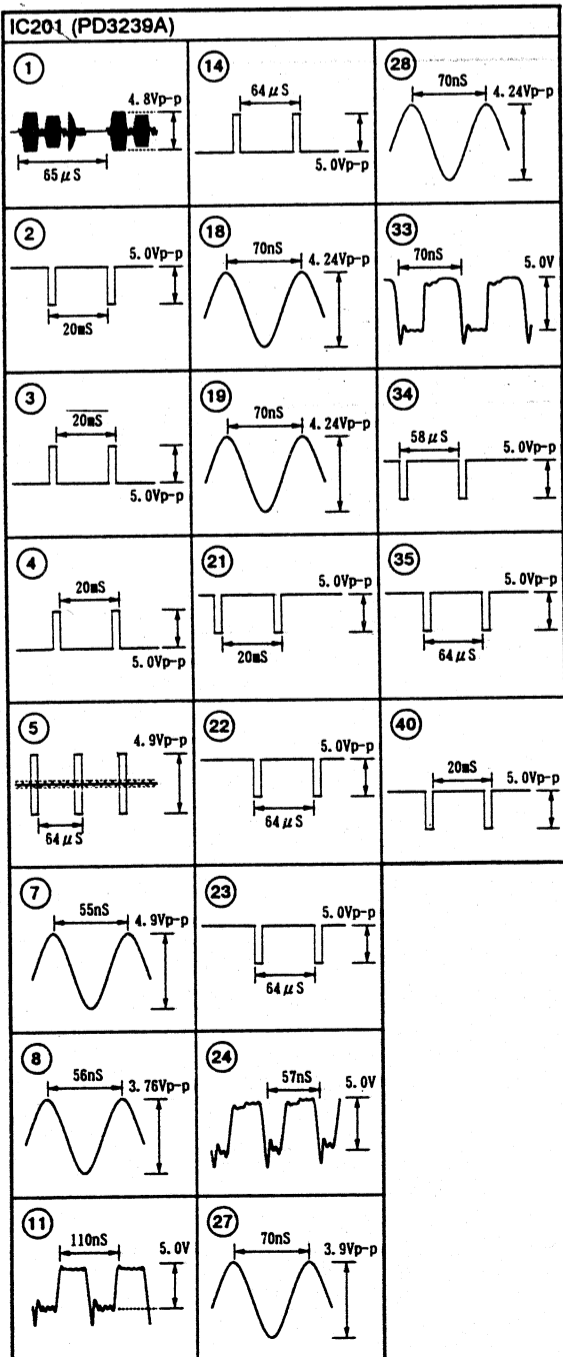
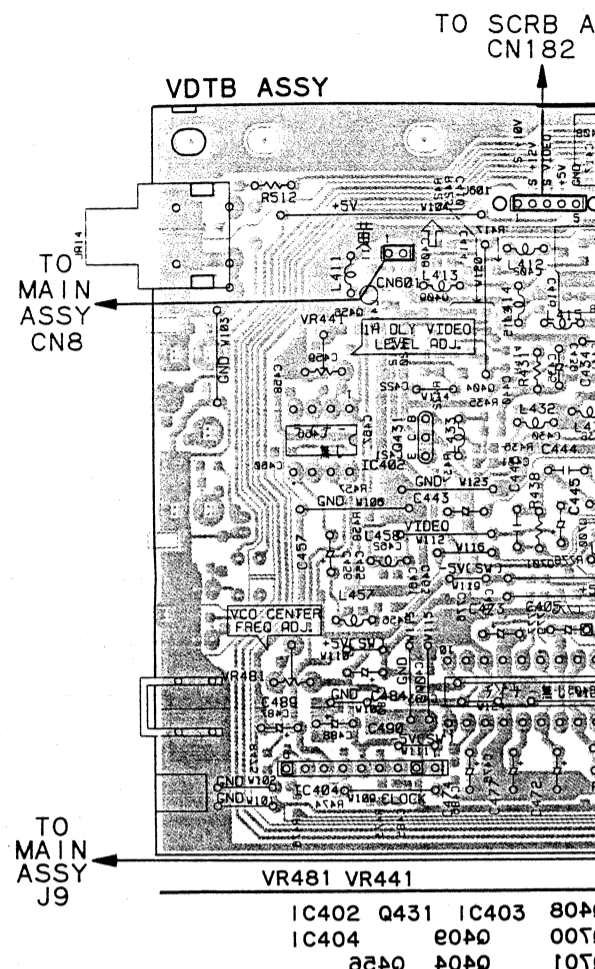
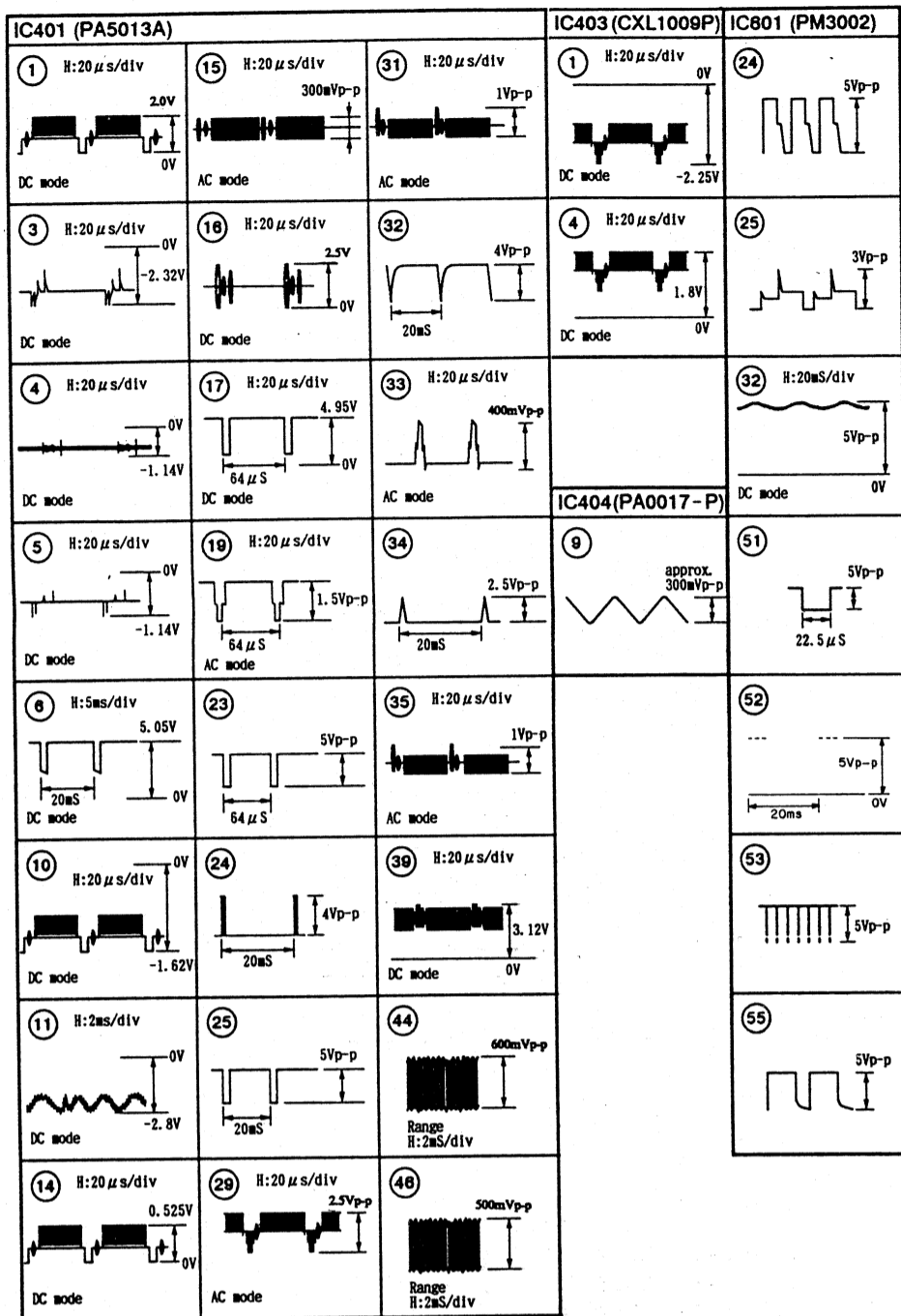

Note: These waveforms and voltage are in the PAL DISC playback.

• IC201 (PD3239A)

Pin No.	Voltage (V)	Pin No.	Voltage (V)	Pin No.	Voltage (V)	Pin No.	Voltage (V)
1	*	12	5.0	23	*	34	*
2	*	13	5.0	24	*	35	*
3	*	14	*	25	0	36	5.0
4	*	15	5.0	26	0	37	5.0
5	*	16	0	27	*	38	5.0
6	0	17	5.0	28	*	39	5.0
7	*	18	*	29	5.0	40	*
8	*	19	*	30	5.0	41	0
9	5.0	20	5.0	31	5.0	42	0
10	0	21	*	32	0	43	5.0
11	*	22	*	33	*	44	5.0

*: Refer to waveforms

PB-4

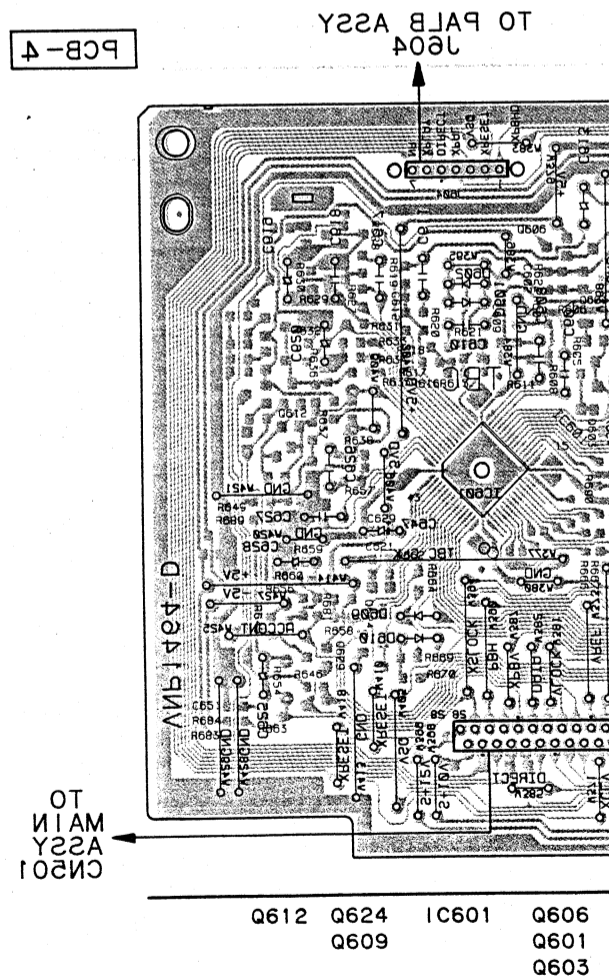

This diagram is viewed from the mounted parts side.

TO SCRB ASSY CN182 TO PALB ASSY J602 TO PALB ASSY J603 TO PALB ASSY J604

PCB-4

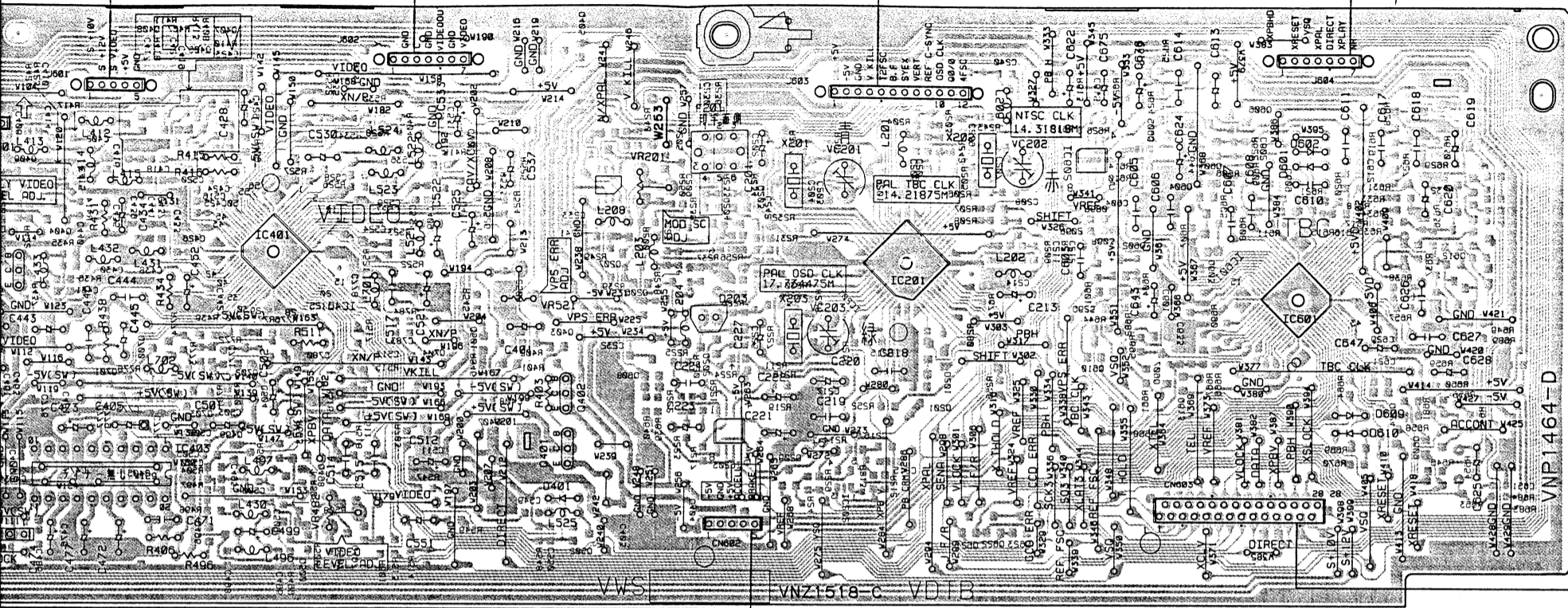

TO MAIN ASSY CN501

	VR482	VR521	VR201	VC203	VC201	VC202								
31	IC403	Q808	Q407	Q703	Q408	Q409	Q404	Q405	Q406	Q407	Q408	Q409	Q404	Q405
	Q404	Q405	Q406	Q407	Q408	Q409	Q404	Q405	Q406	Q407	Q408	Q409	Q404	Q405
	Q406	Q407	Q408	Q409	Q404	Q405	Q406	Q407	Q408	Q409	Q404	Q405	Q406	Q407
	Q408	Q409	Q404	Q405	Q406	Q407	Q408	Q409	Q404	Q405	Q406	Q407	Q408	Q409
	Q404	Q405	Q406	Q407	Q408	Q409	Q404	Q405	Q406	Q407	Q408	Q409	Q404	Q405

This diagram is viewed from the foil side.

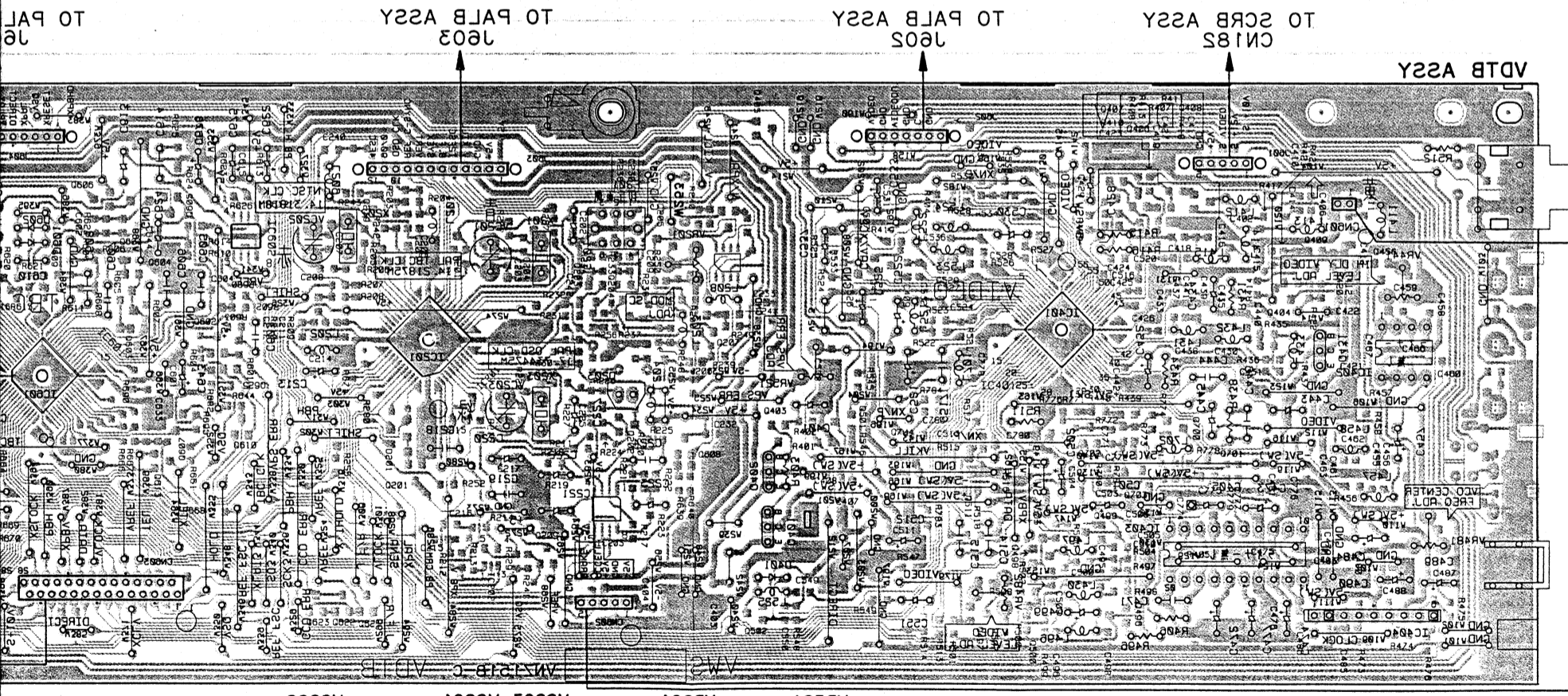

TO MAIN ASSY CN8

TO MAIN ASSY J6

	VC203	VC201	VC202											
1001	Q601	Q605	IC602	Q621	Q201	Q623	Q202	Q205	Q411	Q511	IC401	Q407	Q703	Q408
	Q601	Q604	Q625	Q623	IC201	Q204	Q206	Q207	Q501	Q497	Q498	Q406	Q496	Q700
	Q603	Q602	Q610			Q209		Q403	Q704		Q500	Q702	Q701	Q404
		Q607				IC203	Q608					Q499		Q456
		Q613						Q502						

2.2.5 PALB AND SCRIB ASSEMBLIES

A

B

C

D

E

F

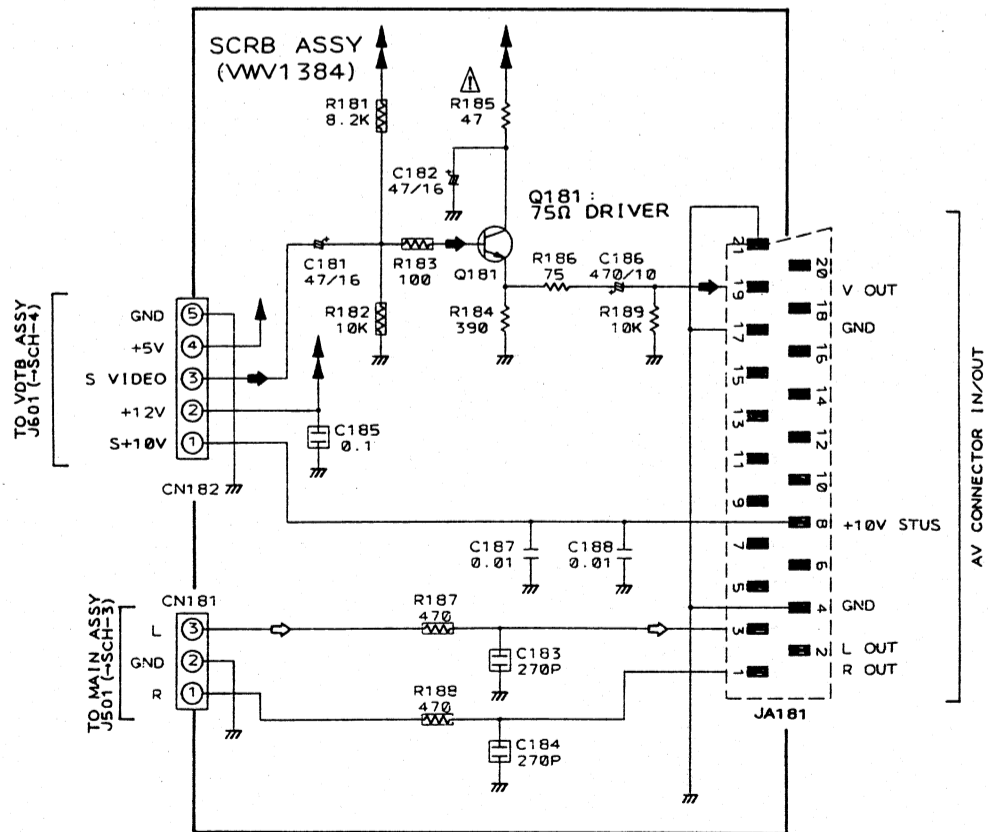
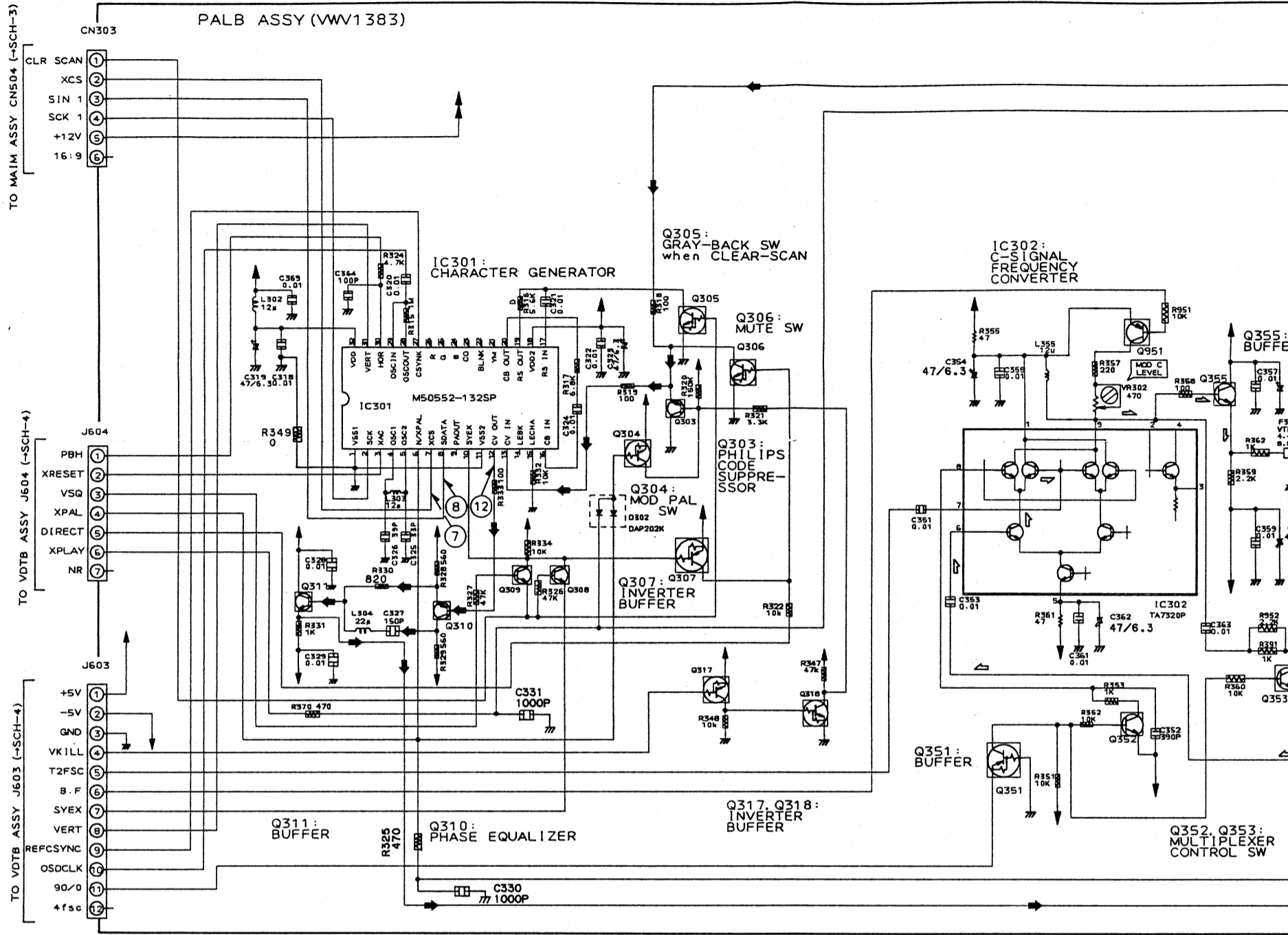

SCH-5

PALB ASSY, SCRIB ASSY

◆ : VIDEO SIGNAL LINE
 ▲ : Y-SIGNAL LINE
 ▤ : C-SIGNAL LINE
 ◇ : AUDIO SIGNAL LINE

SCH-5

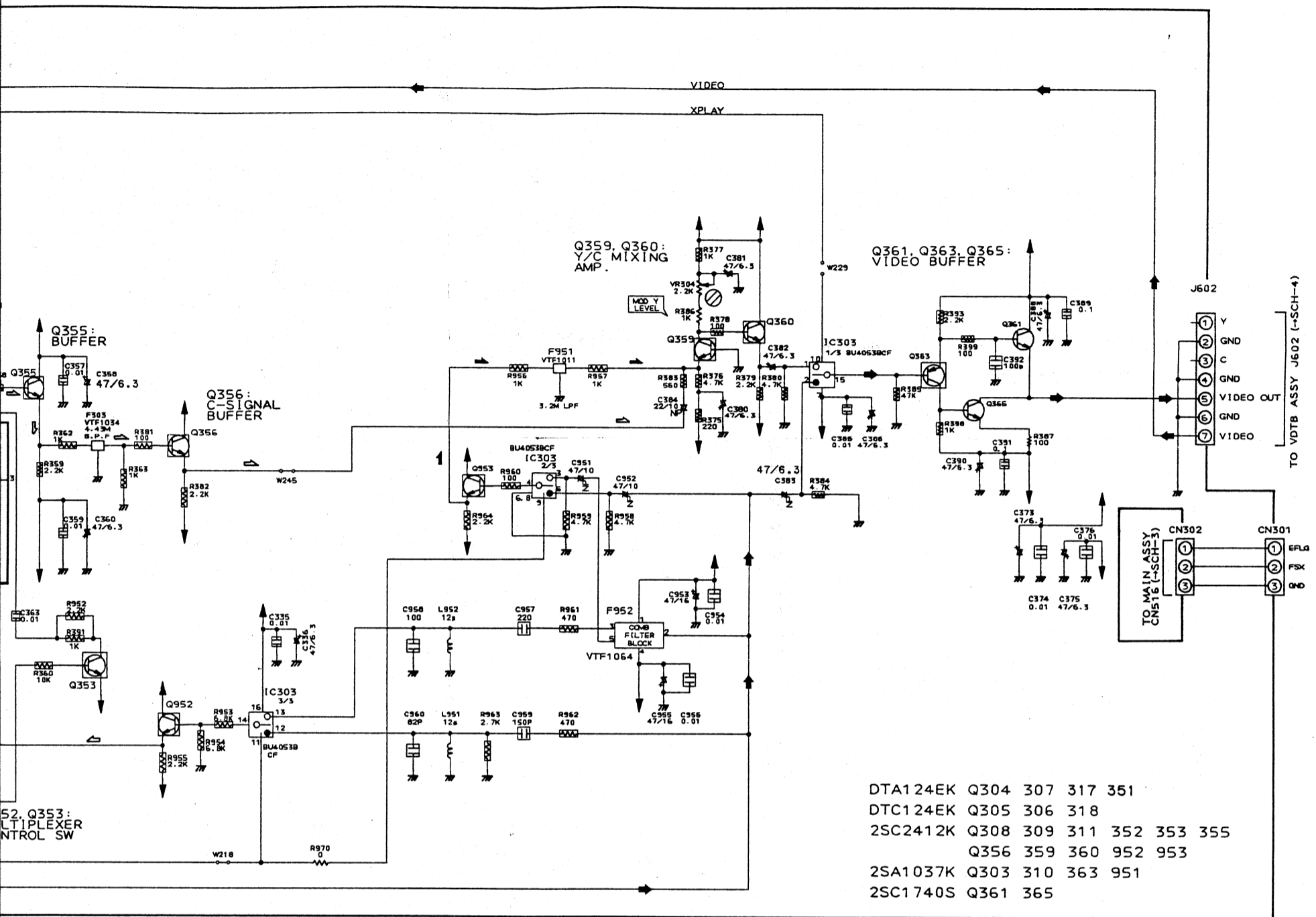

- DTA124EK Q304 307 317 351
- DTC124EK Q305 306 318
- 2SC2412K Q308 309 311 352 353 355
- Q356 359 360 952 953
- 2SA1037K Q303 310 363 951
- 2SC1740S Q361 365

PALB ASSEMBLY

Note: (No.) in the table correspond to the pin number.

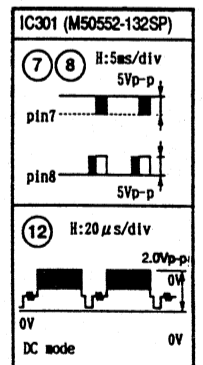

[PALB ASSY]

Note: These waveforms and voltage are in the play mode.

● IC301 (M50552-132SP)

Pin No.	Voltage (V)	Pin No.	Voltage (V)	Pin No.	Voltage (V)	Pin No.	Voltage (V)
1	0	9	-	17	0.8	25	-
2	5	10	5	18	-	26	-
3	5	11	0	19	0	27	-
4	2.4	12	1.1	20	0	28	2.3
5	2.4	13	1.1	21	-	29	2.3
6	-	14	-	22	-	30	-
7	5	15	1.8	23	-	31	-
8	0.4	16	0.6	24	-	32	-

SCH-5

● This diagram is viewed from the mounted parts side.

● This diagram is viewed from the foil side.

PALB ASSY

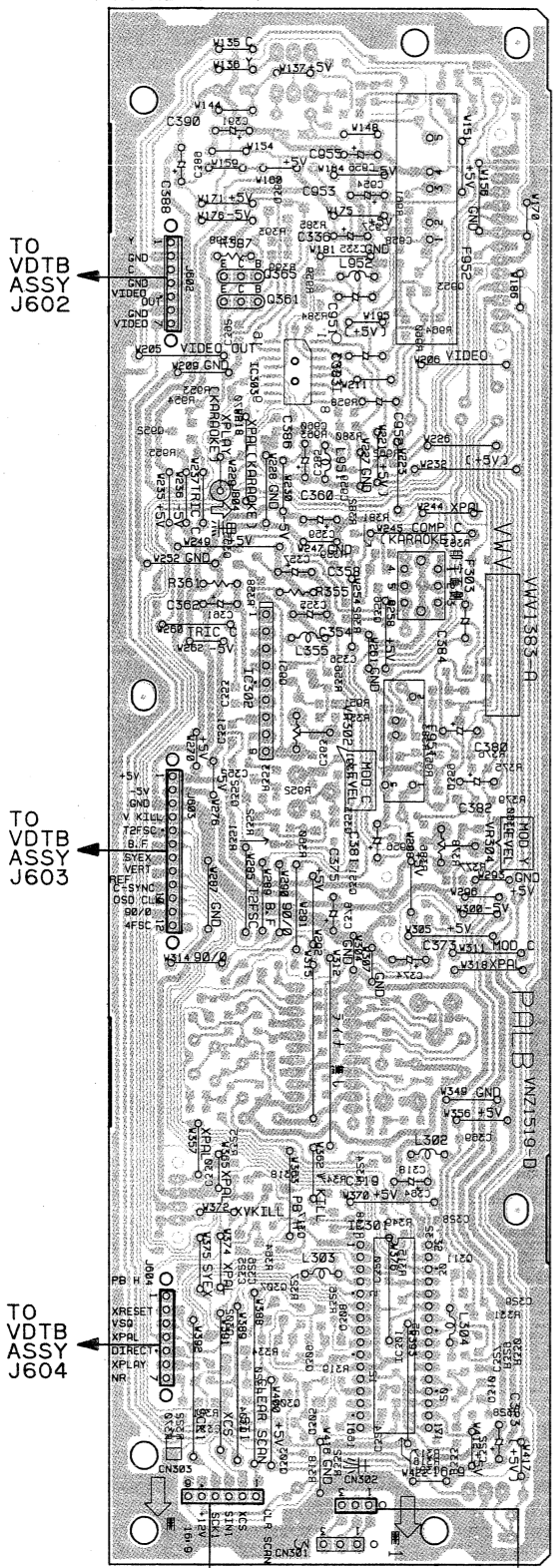

PCB-5

SCRB ASSY

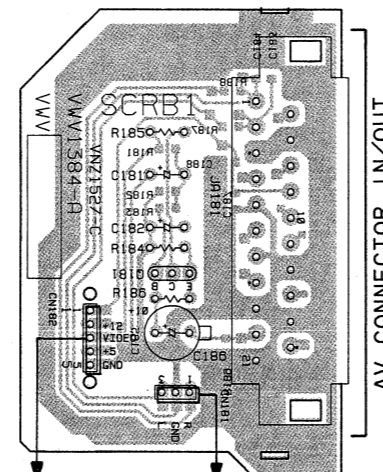

PCB-2

Y2SA ASSY

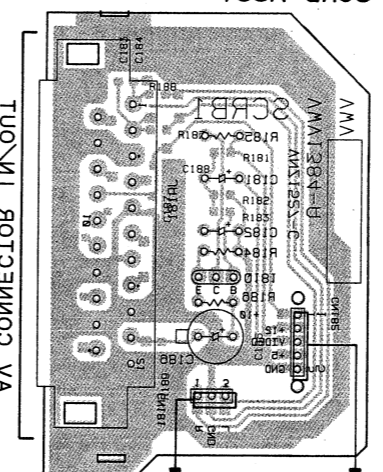

VNP1464-D

VNP1464-D

PALB ASSY

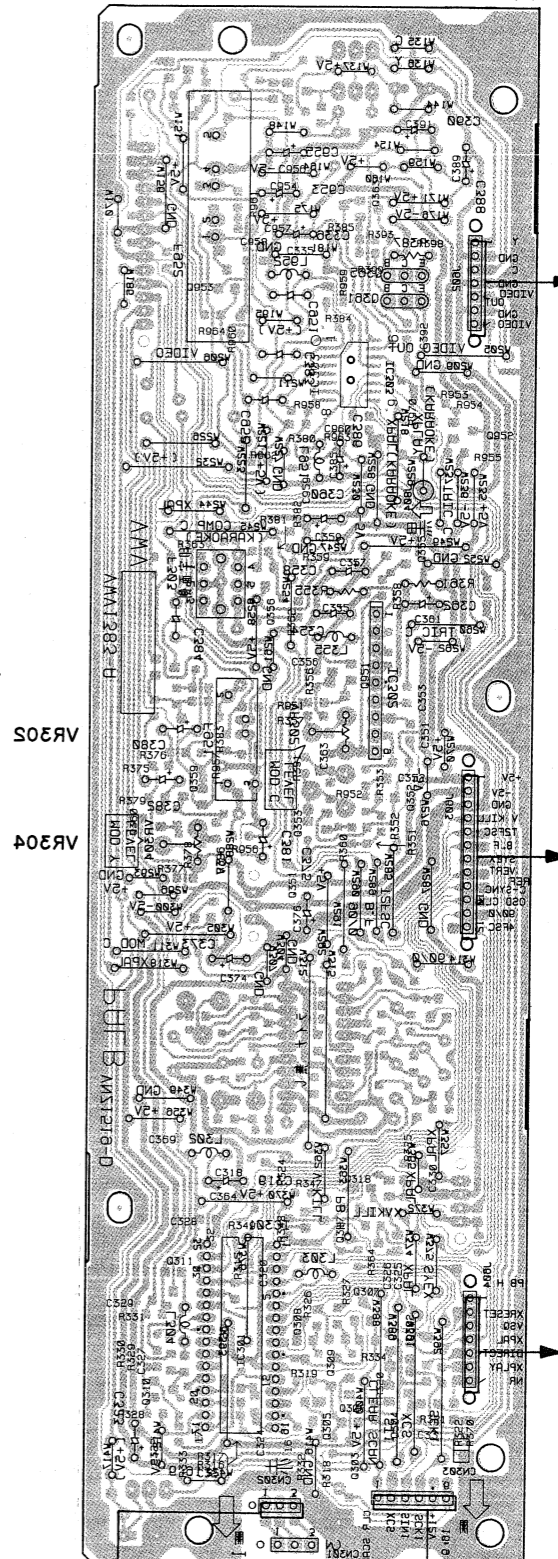

- Q363
- Q366
- Q361
- Q362
- Q303
- Q323
- Q322
- Q320
- Q321
- Q325
- Q380
- Q323
- Q321
- Q318
- Q317
- Q311
- Q307
- Q308
- Q301
- Q310
- Q308
- Q302
- Q304
- Q303

- Q363
- Q362
- Q361
- Q363
- Q303
- Q323
- Q322
- Q320
- Q321
- Q325
- Q380
- Q323
- Q321
- Q318
- Q317
- Q311
- Q307
- Q308
- Q301
- Q310
- Q308
- Q302
- Q304
- Q303

2.2.6 KFCB AND EXTB ASSEMBLIES

NOTE: Measuring condition of voltages and waveforms in the schematic diagram is follows:
Karaoke mode
Playing the disc contains analog and digital audio signals.

(MIC) : AUDIO SIGNAL LINE for ECHO
(MIC) : AUDIO SIGNAL LINE(MIC)
(MIC) : AUDIO SIGNAL LINE(Digital)
(MIC) : AUDIO SIGNAL LINE(Lch)

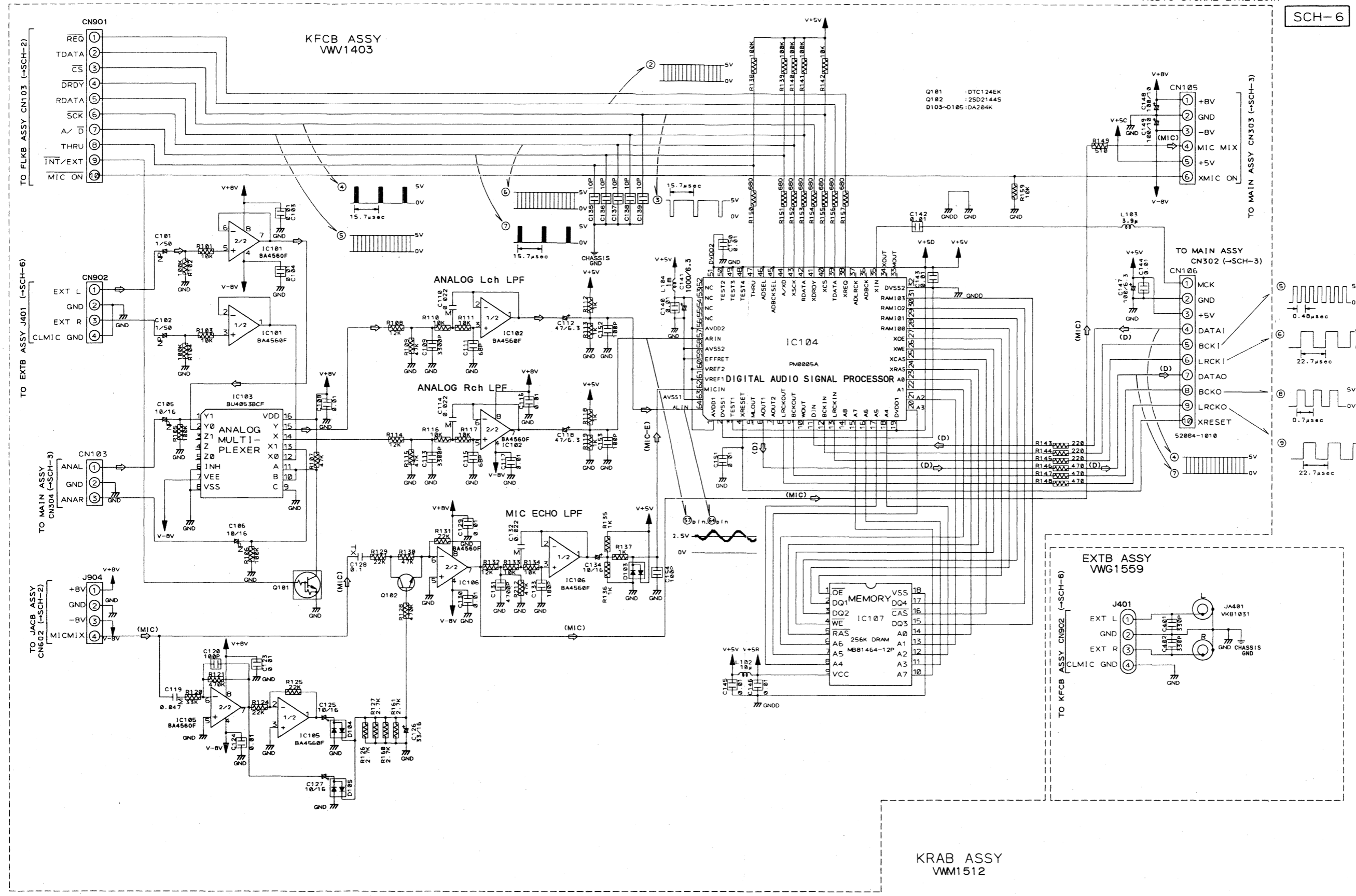

SCH-6

SCH-6 KFCB ASSY, EXTB ASSY

KFCB ASSY, EXTB ASSY SCH-6

● This diagram is viewed from the mounted parts side.

PCB-6

A

B

C

D

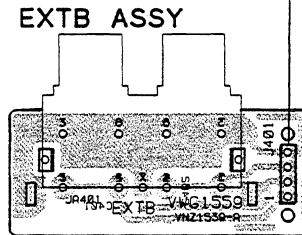
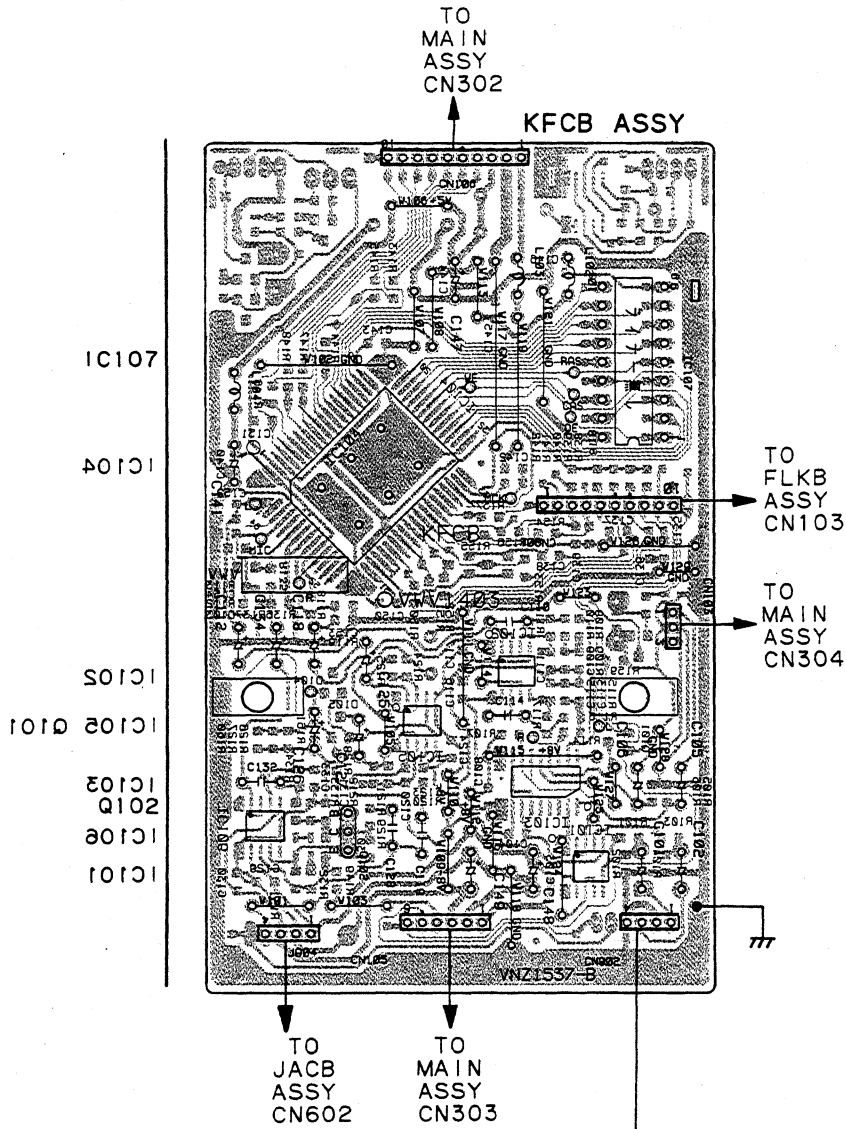

VNP1480-B

● This diagram is viewed from the foil side.

PCB-e

