

Service Manual

PIONEER
The Art of Entertainment

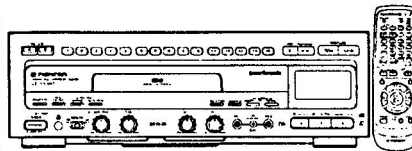

• CLD-V860

ORDER NO.
RRV1358

CD CDV LD PLAYER

CLD-V860

CLD-2750K

THIS MANUAL IS APPLICABLE TO THE FOLLOWING MODEL(S) AND TYPE(S).

Type	Model		Power Requirement	Remarks
	CLD-V860	CLD-2750K		
KU	○	—	AC120V	
KC	○	—	AC120V	
RD	—	○	AC110-127V/220-240V	Automatic select
RDXIN	—	○	AC110-127V/220-240V	Automatic select

CONTENTS

1. SAFETY INFORMATION	2	5. SELF-DIAGNOSTIC FUNCTIONS	46
2. EXPLODED VIEWS, PACKING AND PARTS LIST	3	6. ADJUSTMENTS	48
3. SCHEMATIC AND PCB CONNECTION DIAGRAMS	15	7. IC INFORMATION	58
4. PCB PARTS LIST	41	8. BLOCK DIAGRAM	71
		9. PANEL FACILITIES	73
		10. SPECIFICATIONS	74

PIONEER ELECTRONIC CORPORATION 4-1, Meguro 1-Chome, Meguro-ku, Tokyo 153, Japan
PIONEER ELECTRONICS SERVICE, INC. P.O. Box 1760, Long Beach, CA 90801-1760, U.S.A.
PIONEER ELECTRONIC (EUROPE) N.V. Haven 1087, Keetberglaan 1, 9120 Melsele, Belgium
PIONEER ELECTRONICS ASIACENTRE PTE. LTD. 501 Orchard Road, #10-00 Lane Crawford Place, Singapore 0923
 © PIONEER ELECTRONIC CORPORATION 1995

1. SAFETY INFORMATION

This service manual is intended for qualified service technicians; it is not meant for the casual do-it-yourselfer. Qualified technicians have the necessary test equipment and tools, and have been trained to properly and safely repair complex products such as those covered by this manual. Improperly performed repairs can adversely affect the safety and reliability of the product and may void the warranty. If you are not qualified to perform the repair of this product properly and safely, you should not risk trying to do so and refer the repair to a qualified service technician.



WARNING

Lead in solder used in this product is listed by the California Health and Welfare agency as a known reproductive toxicant which may cause birth defects or other reproductive harm (California Health & Safety Code, Section 25249.5).

When servicing or handling circuit boards and other components which contain lead in solder, avoid unprotected skin contact with the solder. Also, when soldering do not inhale any smoke or fumes produced.



NOTICE

(FOR CANADIAN MODEL ONLY)

Fuse symbols  (fast operating fuse) and/or  (slow operating fuse) on PCB indicate that replacement parts must be of identical designation.

REMARQUE

(POUR MODÈLE CANADIEN SEULEMENT)

Les symboles de fusible  (fusible de type rapide) et/ou  (fusible de type lent) sur CCI indiquent que les pièces de remplacement doivent avoir la même désignation.

(FOR USA MODEL ONLY)

1. SAFETY PRECAUTIONS

The following check should be performed for the continued protection of the customer and service technician.

LEAKAGE CURRENT CHECK

Measure leakage current to a known earth ground (water pipe, conduit, etc.) by connecting a leakage current tester such as Simpson Model 229-2 or equivalent between the earth ground and all exposed metal parts of the appliance (input/output terminals, screwheads, metal overlays, control shaft, etc.). Plug the AC line cord of the appliance directly into a 120V AC 60Hz outlet and turn the AC power switch on. Any current measured must not exceed 0.5mA.

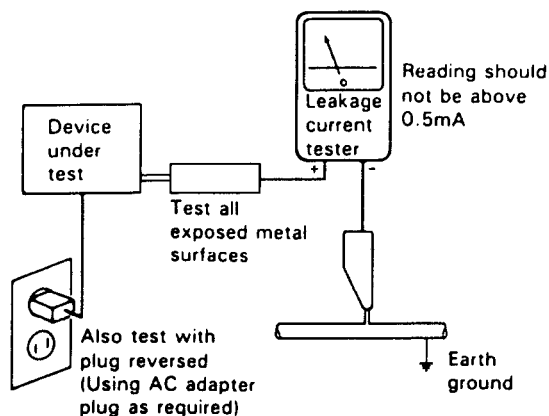

AC Leakage Test

ANY MEASUREMENTS NOT WITHIN THE LIMITS OUTLINED ABOVE ARE INDICATIVE OF A POTENTIAL SHOCK HAZARD AND MUST BE CORRECTED BEFORE RETURNING THE APPLIANCE TO THE CUSTOMER.

2. PRODUCT SAFETY NOTICE

Many electrical and mechanical parts in the appliance have special safety related characteristics. These are often not evident from visual inspection nor the protection afforded by them necessarily can be obtained by using replacement components rated for voltage, wattage, etc. Replacement parts which have these special safety characteristics are identified in this Service Manual.

Electrical components having such features are identified by marking with a Δ on the schematics and on the parts list in this Service Manual.

The use of a substitute replacement component which does not have the same safety characteristics as the PIONEER recommended replacement one, shown in the parts list in this Service Manual, may create shock, fire, or other hazards.

Product Safety is continuously under review and new instructions are issued from time to time. For the latest information, always consult the current PIONEER Service Manual. A subscription to, or additional copies of, PIONEER Service Manual may be obtained at a nominal charge from PIONEER.

2. EXPLODED VIEWS, PACKING AND PARTS LIST

NOTES:

- Parts marked by "NSP" are generally unavailable because they are not in our Master Spare Parts List.
- The Δ mark found on some component parts indicates the importance of the safety factor of the part. Therefore, when replacing, be sure to use parts of identical designation.
- Parts marked by "⊙" are not always kept in stock. Their delivery time may be longer than usual or they may be unavailable.

2.1 EXTERIOR AND DISC TRAY SECTION

(1) CONTRAST OF CLD - V860/KU, KC, CLD - 2750K/RD AND RDXIN.

CLD - V860/KU, KC, CLD - 2750K/RD and RDXIN have the same construction except for the following:

Mark	No.	Symbol & Description	Part No.				Remarks
			CLD - V860/KU	CLD - V860/KC	CLD - 2750K/RD	CLD - 2750K/RDXIN	
	1	Bonnet S	VXX2355	VXX2252	VXX2252	VXX2252	
	4	Rear cover	VNK3301	VNK3301	VNK3300	VNK3486	
	15	CD door assy	VXA2235	VXA2235	VXA2250	VXA2250	
	19	Tray panel	VNK3280	VNK3280	VNK3399	VNK3399	
	22	65 label	ORW1069	Not used	Not used	Not used	

(2) PARTS LIST FOR CLD - V860/KU

Mark	No.	Description	Part No.	Mark	No.	Description	Part No.
	1	Bonnet S	VXX2355		6	Guide plate (L)	VNE1938
	2	Screw	BBZ30P080FMC		7	CD tray	VNK3007
	3	Screw	BCZ40P060FZK		8	Lock plate	VNL1703
	4	Rear cover	VNK3301		9	Lock plate spring	VBH1188
	5	Guide plate (R)	VNE1939		10	Tray assy - S	VXX2307
					11	Cushion	VEC1682
					12	Damp cushion	VEC1683
				NSP	13	Label	VRW1289
					14	LD tray assy	VXA2173
					15	CD door assy	VXA2235
					16	Door spring	VBH1248
					17	Door holder	VNE2028
					18	Damper assy	VXA1999
					19	Tray panel	VNK3280
					20	Name plate	PAM1608
					21	KARAOKE badge	VAM1055
					22	65 label	ORW1069

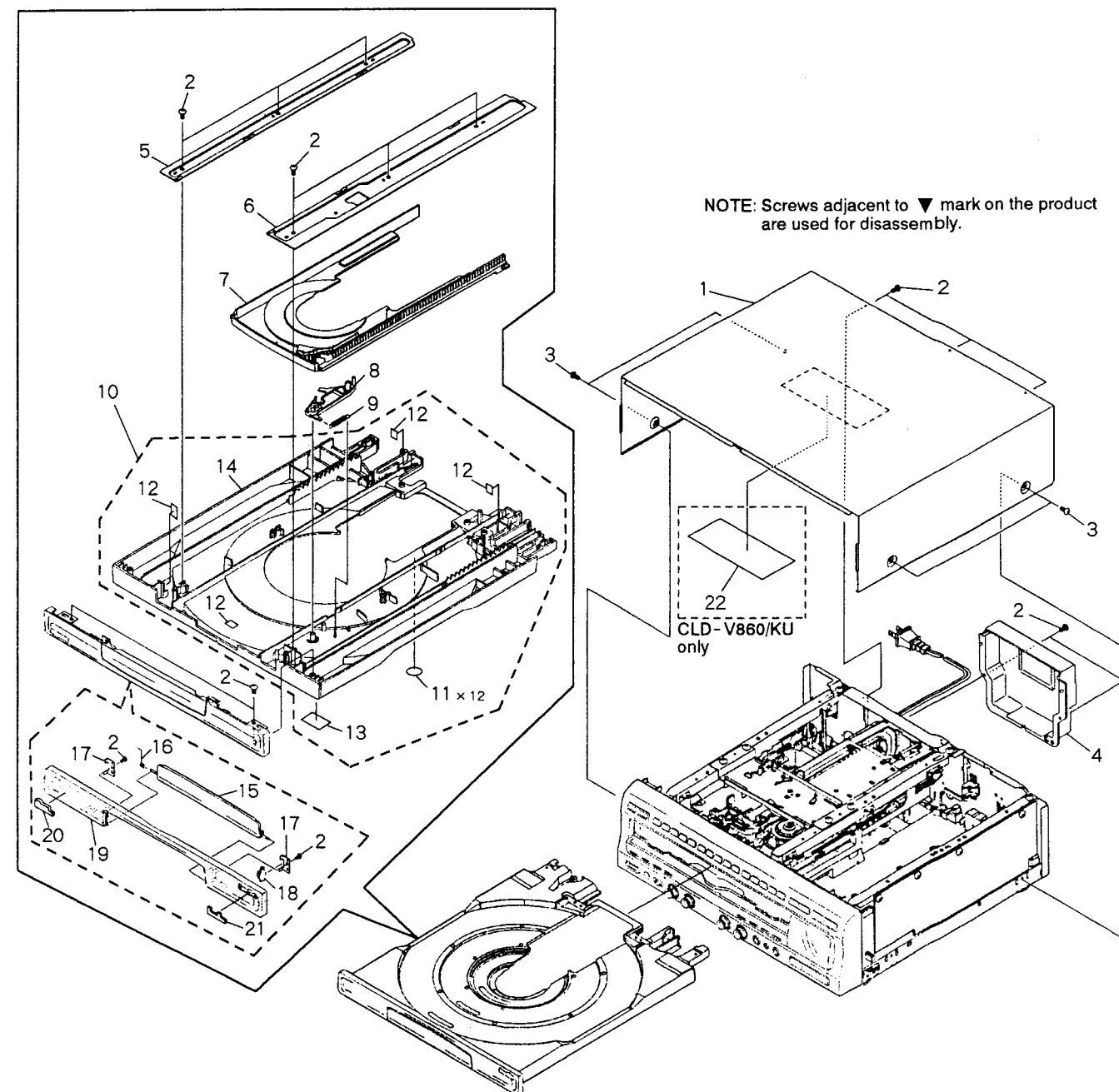

2.2 TOP VIEW SECTION

(1) CONTRAST OF CLD - V860/KU, KC, CLD - 2750K/RD AND RDXIN.

CLD - V860/KU, KC, CLD - 2750K/RD and RDXIN have the same construction except for the following:

Mark	No.	Symbol & Description	Part No.				Remarks
			CLD - V860/KU	CLD - V860/KC	CLD - 2750K/RD	CLD - 2750K/RDXIN	
	18	GYCB assy	VWV1434	VWV1434	Not used	Not used	

(2) PARTS LIST FOR CLD - V860/KU

Mark	No.	Description	Part No.
	1	Screw	PBZ20P060FMC
	2	D lever assy	VXA2205
	3	Clamper holder	VNE1971
	4	Rubber mat	VEB1114
	5	Thrust holder	VNL1663
	6	Clamper head	VNL1603
	7	LD spring	VBH1240
	8	Cover spring	VBH1234
	9	Ball cover	VNL1602
	10	LD hab	VNT1047
	11	Ball	VNX1013
	12	Ball guide	VNL1616
	13	Clamp spring	VBH1239
	14	Clamper	VNL1604
	15	Clamper holder	VNL1680
NSP	16	Center angle	VNE1965
	17	PCB holder	VNE1964
	18	GYCB assy	VWV1434
	19	Screw	IBZ30P080FMC
	20	Screw	BBZ30P080FMC
NSP	21	Damp cushion	VEC1602
	22	KRAB assy	VWG1640
	23	Flexible cable (18P)	VDA1517

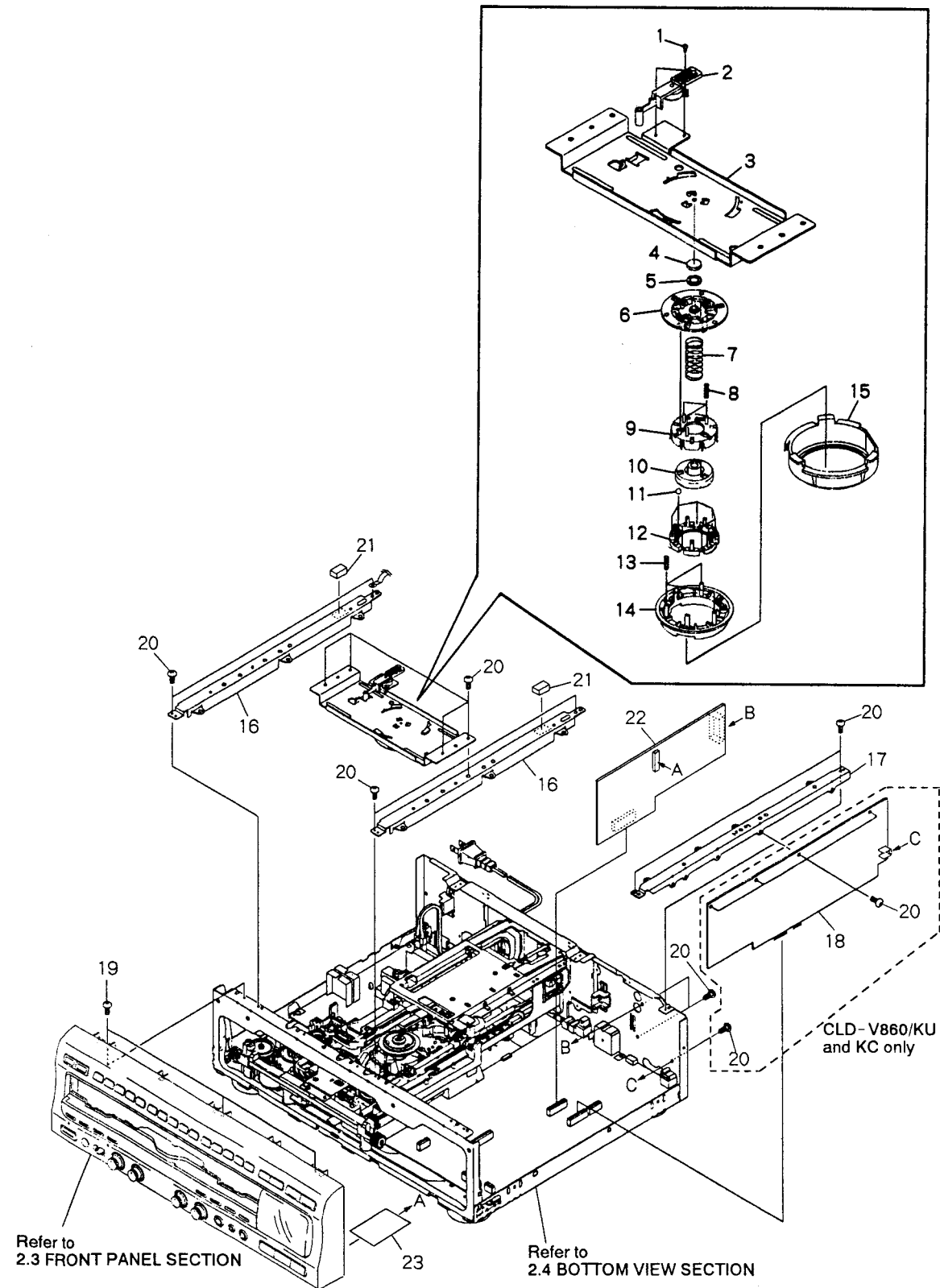

A

B

C

D

2.3 FRONT PANEL SECTION

A (1) CONTRAST OF CLD - V860/KU, KC, CLD - 2750K/RD AND RDXIN.

CLD - V860/KU, KC, CLD - 2750K/RD and RDXIN have the same construction except for the following:

Mark	No.	Symbol & Description	Part No.				Remarks
			CLD - V860/KU	CLD - V860/KC	CLD - 2750K/RD	CLD - 2750K/RDXIN	
	1	Decoration panel	VNK3295	VNK3295	VNK3407	VNK3407	
	4	Front panel	VNK3276	VNK3276	VNK3274	VNK3274	
	22	KALB assy	VWG1667	VWG1667	VWG1676	VWG1676	
	24	FLKB assy	VWG1665	VWG1665	VWG1671	VWG1671	

(2) PARTS LIST FOR CLD - V860/KU

Mark	No.	Description	Part No.	Mark	No.	Description	Part No.
	1	Decoration panel	VNK3295		16	Play button	VNK3238
	2	FL panel	VNK3176		17	O/C button	VNK3377
	3	VR knob	VNK3180		18	Slide knob	VNK3187
B	4	Front panel	VNK3276	NSP	19	VRSB assy	VWG1643
	5	LED lens	PNW2019	NSP	20	JACB assy	VWV1422
	6	PW button	VNK3179		21	Earth plate	VNE2027
	7	IR window	VNK2246		22	KALB assy	VWG1667
	8	•••••		NSP	23	DIKB assy	VWG1635
	9	L key A	VNK3378		24	FLKB assy	VWG1665
	10	L key B	VNK3379		25	Screw	BBZ30P080FMC
	11	Screw	BBZ26P060FMC				
	12	Key A	VNK3177				
	13	Key control button	VNK3241				
	14	A/B button	VNK3240				
	15	15 key	VNK3237				

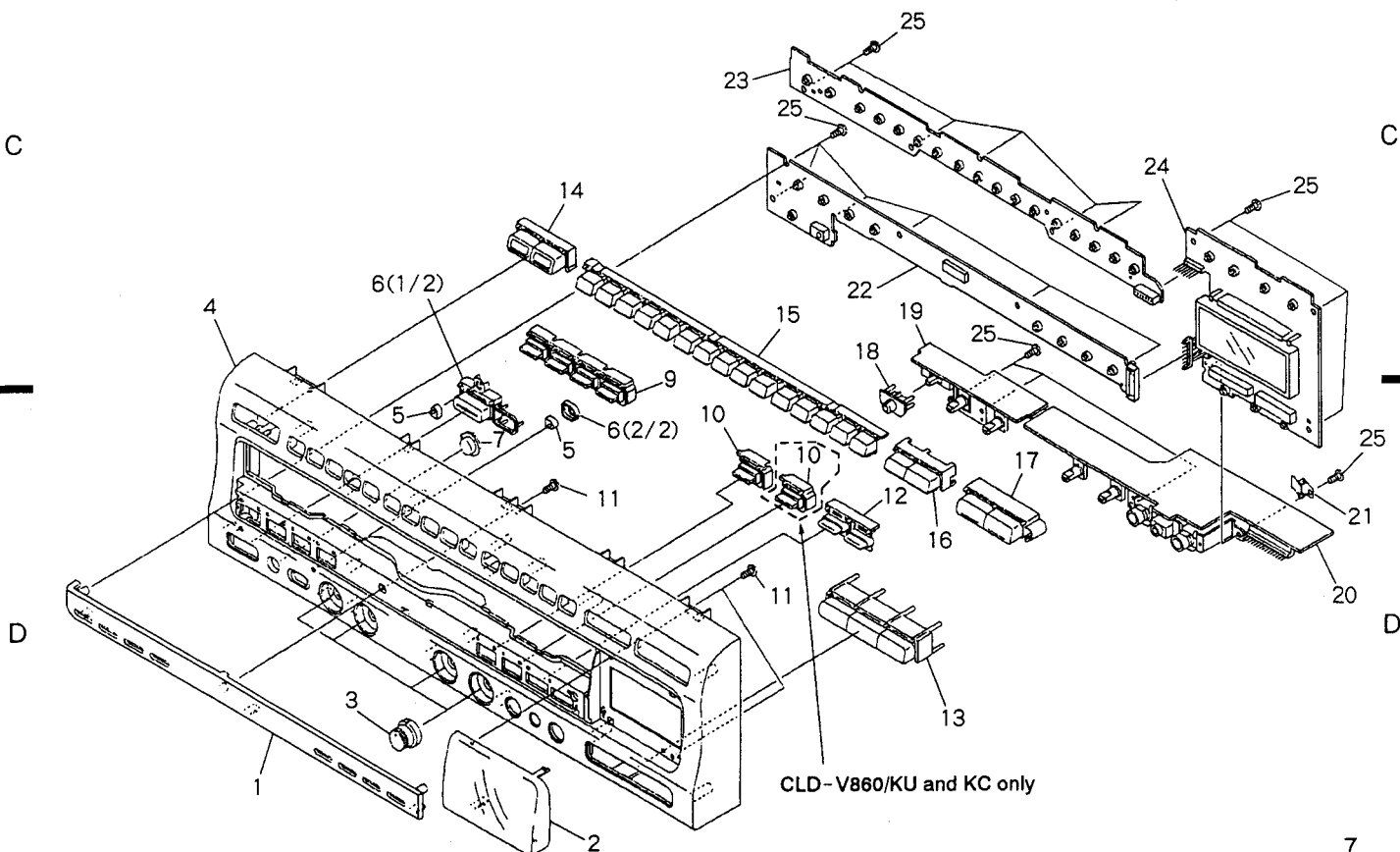

2.4 BOTTOM VIEW SECTION

(1) CONTRAST OF CLD - V860/KU, KC, CLD - 2750K/RD AND RDXIN.

CLD - V860/KU, KC, CLD - 2750K/RD and RDXIN have the same construction except for the following:

Mark	No.	Symbol & Description	Part No.				Remarks
			CLD - V860/KU	CLD - V860/KC	CLD - 2750K/RD	CLD - 2750K/RDXIN	
	1	MOTHER assy	VWS1216	VWS1216	VWS1203	VWS1203	
△	3	SYPS assy	VWR1260	VWR1260	VWR1247	VWR1247	
△	4	AC power cord	VDG1057	VDG1057	Not used	Not used	
△	5	AC cord stopper	CM - 22C	CM - 22C	Not used	Not used	
	7	Rear panel (R)	VNA1532	VNA1532	VNA1606	VNA1606	
NSP	14	Chassis	VNA1461	VNA1461	VNA1564	VNA1564	
	15	Rear panel (L)	VNA1631	VNA1631	VNA1570	VNA1570	
	23	F.ICP caution label	VRW1525	VRW1525	Not used	Not used	
NSP	24	Fuse caution label	VRW - 548	VRW - 548	Not used	Not used	
△	25	AC inlet assy	Not used	Not used	VKP2116	VKP2116	

(2) PARTS LIST FOR CLD - V860/KU

Mark	No.	Description	Part No.	Mark	No.	Description	Part No.
	1	MOTHER assy	VWS1216	NSP	11	Wire clip (H)	VEC1181
	2	Screw	BBZ30P080FMC		12	Insulator	PNW1912
△	3	SYPS assy	VWR1260		13	Card spacer	VEC1708
△	4	AC power cord	VDG1057	NSP	14	Chassis	VNA1461
△	5	AC cord stopper	CM - 22C		15	Rear panel (L)	VNA1631
	6	Tray stopper	VNL1657		16	Spacer	REB1171
	7	Rear panel (R)	VNA1532		17	Flexible cable (21P)	VDA1465
NSP	8	P plate holder	PNY - 405		18	Flexible cable (21P)	VDA1516
NSP	9	PC support	VEC - 269	NSP	19	Panel holder	VNA1507
NSP	10	PCB hinge	VEC1174		20	Screw	BBZ30P100FMC
				NSP	21	Mechanism assy	VWT1128
				NSP	22	Rubber spacer	VEB1252
					23	F.ICP caution label	VRW1525
				NSP	24	Fuse caution label	VRW - 548
					25	• • • • •	

1

2

A

A

B

B

C

C

D

D

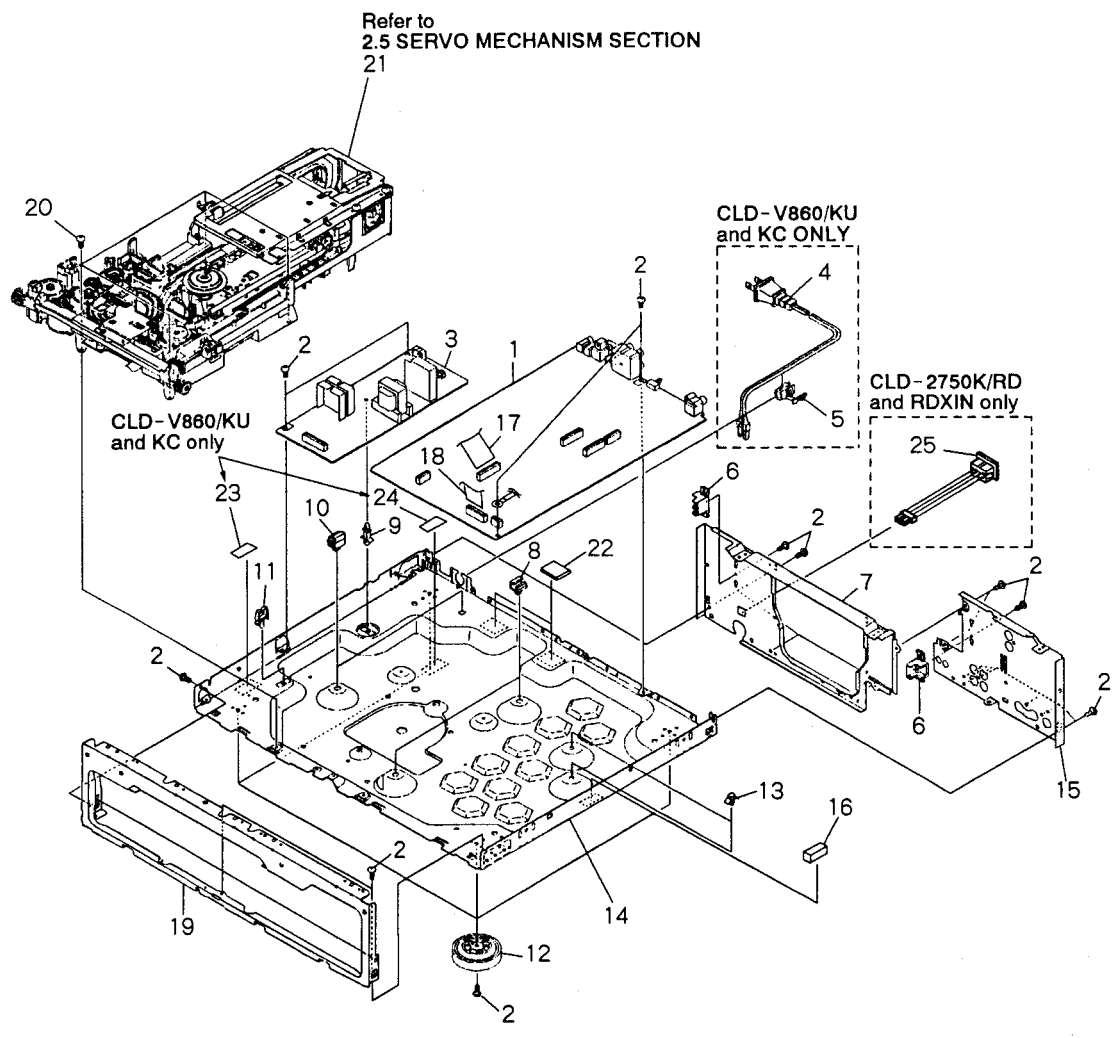

1

2

3

9

2.5 SERVO MECHANISM SECTION

(1) CONTRAST OF CLD - V860/KU, KC, CLD - 2750K/RD AND RDXIN.

CLD - V860/KU, KC, CLD - 2750K/RD and RDXIN have the same construction except for the following:

Mark	No.	Symbol & Description	Part No.				Remarks
			CLD - V860/KU	CLD - V860/KC	CLD - 2750K/RD	CLD - 2750K/RDXIN	
	59	Carriage assy	VWT1110	VWT1110	VWT1110	VXZ1005	

(2) CARRIAGE ASSY

VXZ1005 and VWT1110 have the same construction except for the following:

Mark	Symbol & Description	Part No.		Remarks
		VWT1110	VXZ1005	
	Cover	Not used	VHC1018	
	Mirror mat	Not used	VHC1019	
	Pickup tray	Not used	VHF1029	
	Packing case	Not used	VHG1441	

Note : All parts are packing materials for VWT1110. VXZ1005 include VWT1110.

(3) PARTS LIST FOR CLD - V860/KU

Mark	No.	Description	Part No.	Mark	No.	Description	Part No.
NSP	1	Tilt base (upper)	VNE1969	NSP	31	Housing assy (3P, yellow)	VKP2046
	2	BISB assy	VWG1558		32	FG assy	VWG1556
	3	Screw	BBZ30P060FMC		33	FG base	VNL1645
	4	A horn	VNL1689		34	Tilt cam	VNL1643
	5	Rack (upper)	VNL1679		35	Tilt cam spring	VBH1243
	6	Shaft stay	VNL1671		36	Screw	PMA30P070FMC
	7	Carriage shaft (upper)	VLL1478		37	Screw	IBZ26P120FMC
	8	B cam	VNL1673		38	Motor base	VNE1975
	9	Shaft support	VNL1672		39	Motor spacer	VNE2007
	10	Support spring	VBH1265		40	Spindle motor assy	VXA2208
	11	SW lever (B)	VNL1678		41	PRC hub	VNL1684
	12	Large hill	VNL1682		42	Centering spring	VBH1269
	13	Flexible cable (23P)	VDA1490		NSP 43	R turn table assy	VXA2225
	14	Turn guide	VNL1701		NSP 44	Oil stopper	VBFB1002
	15	FFC style shaft	VLL1474		NSP 45	Spindle motor	VXM1061
NSP	16	Guide	VNL1674	46	Housing assy (12P)	VKP2099	
	17	Lever spring	VBH1266	47	Screw	BBZ30P060FMC	
	18	Turn gear	VNL1702	48	Screw	IBZ26P060FMC	
	19	SW lever (T)	VNL1695	49	Screw	BPZ20P040FZK	
	20	TNSB assy	VWG1557	50	Housing assy	VKP2060	
	21	Housing assy (3P, black)	VKP2059	NSP	51	Earth lead unit	VDA1494
	22	Tilt base (under)	VNL1670		52	Carriage shaft (under)	VLL1458
	23	TAN guide	VNE1973		53	Body guard	VNL1681
	24	CA rack	VNL1647		54	FFC holder	VNL1656
	25	FFC style spring	VBH1270		55	CA guide	VNL1668
NSP	26	Thrust spring	VBH1245	56	TAN spring (B)	VBH1264	
	27	CA - SW lever	VNL1644	57	TAN lever (B)	VNL1669	
	28	PKSB assy	VWG1555	58	Screw	PMZ20P060FZK	
	29	Housing assy (3P, blue)	VKP2045	59	Carriage assy	VWT1110	
	30	Tilt spring	VBH1263	NSP	60	Cord binder	ZCB - 069Z
					61	Screw	BBZ30P080FMC
				62	Screw	BBZ26P060FMC	

1

2

A

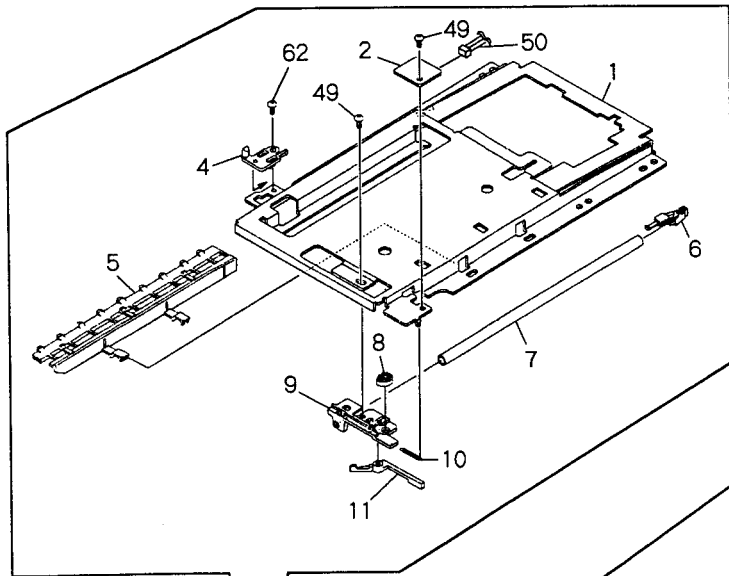

B

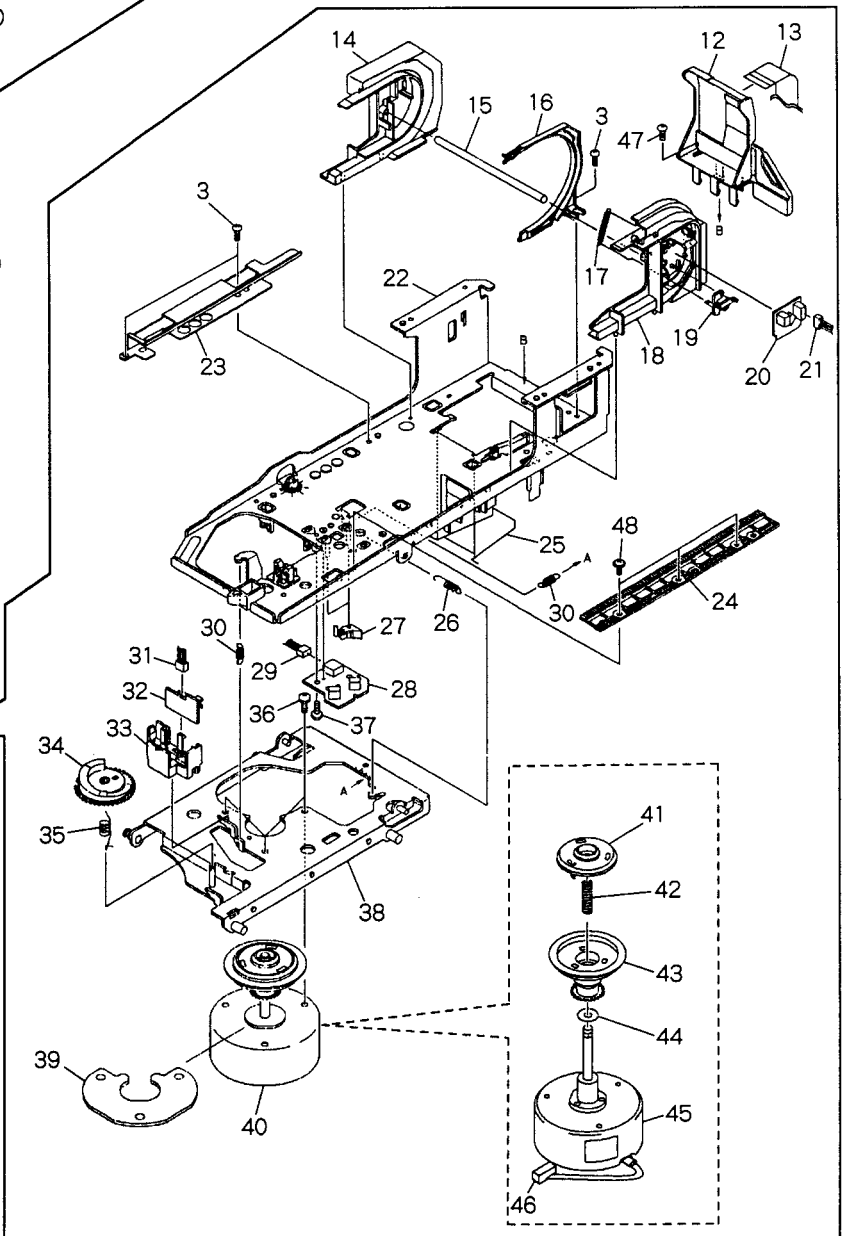

C

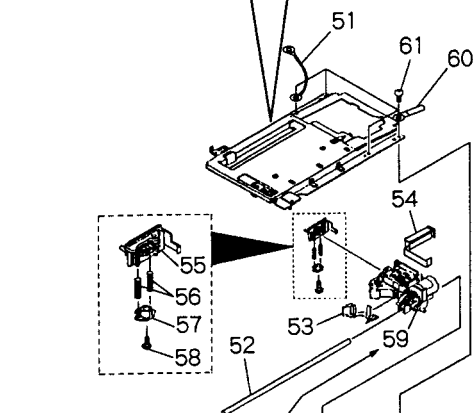

Refer to
2.7 CARRIAGE ASSY

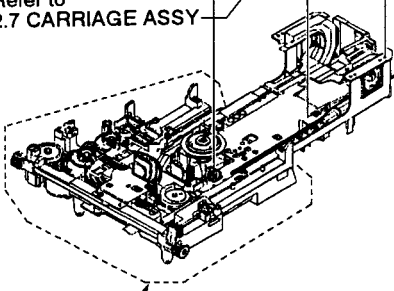

Refer to
2.6 LOADING MECHANISM SECTION

D

1

2

3

2.6 LOADING MECHANISM SECTION

Parts List

A

Mark	No.	Description	Part No.
	1	Clamp cam	VNL1633
	2	CDP spring	VBH1191
	3	Screw	Z39-019
	4	CD plate	VNL1685
	5	Rubber belt	VEB1184
	6	Gear pulley	VNL1662
	7	Twin gear	VNL1626
	8	Center gear	VNL1660
	9	Mechanism base	VNK3239
	10	Screw	BMZ26P040FMC

	11	Roller	VNL1042
NSP	12	Motor pulley	VNL1630
	13	Synchro gear assy	VXA2105
NSP	14	LMSB assy	VWG1612
	15	Cam holder	VNE2032

B

NSP	16	Carriage motor	VXM1033
	17	Shaft holder	VNE1942
	18	CAS spring	VBH1190
	19	Cam plate	VNL1631
	20	Cam gear	VNL1625

	21	Loading motor assy	VXX2045
	22	MB-SW lever	VNL1664
	23	Slider (R)	VNL1666
	24	Slider (L)	VNL1665
	25	Double gear	VNL1661

	26	Flexible cable (12P)	VDA1485
--	----	----------------------	---------

C

D

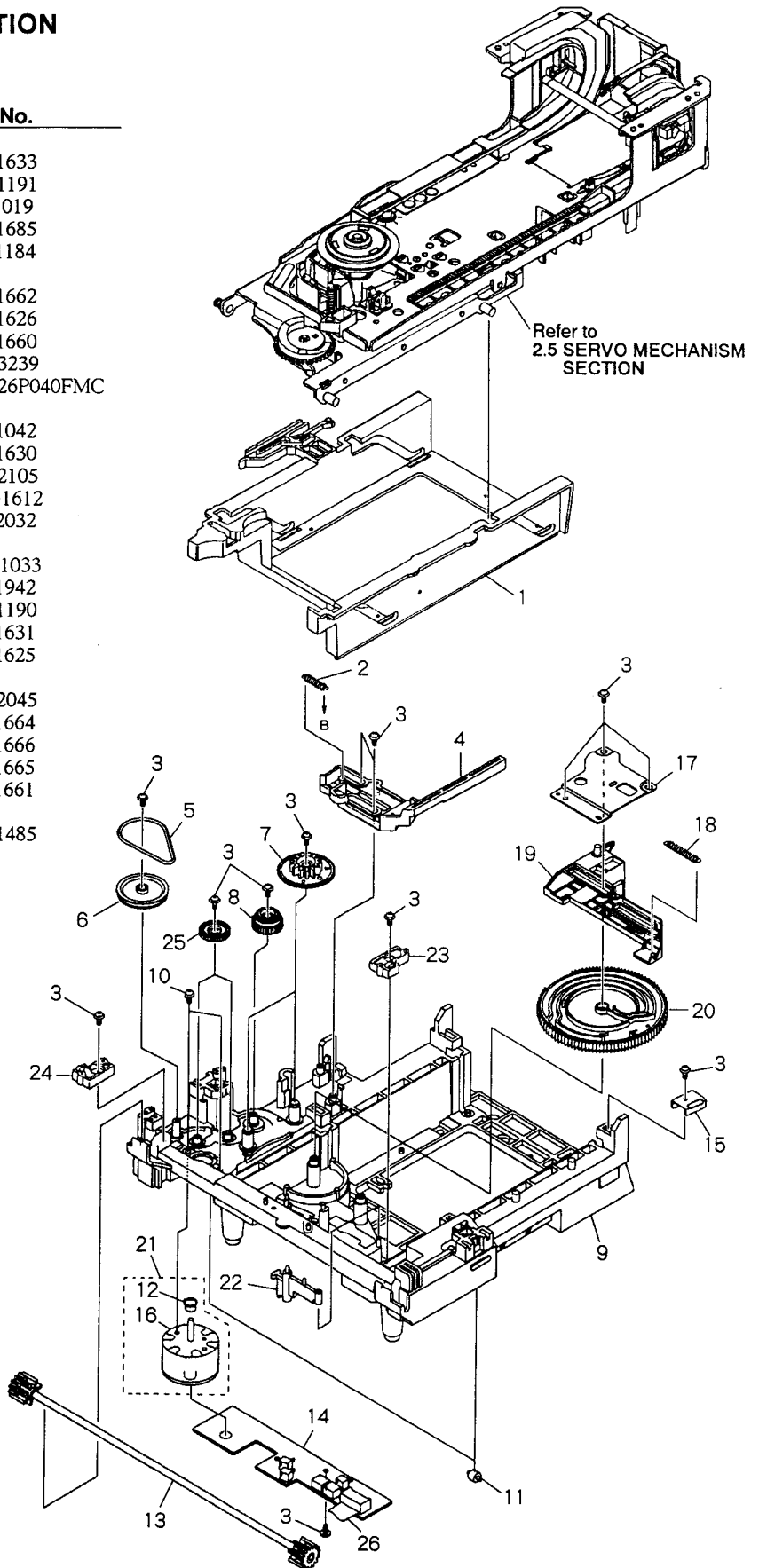

A

B

C

D

2.7 CARRIAGE ASSY

A Parts List

Mark No.	Description	Part No.
1	CA gear (A)	VNL1638
2	CA gear (B)	VNL1639
3	Slider motor assy	VXX2082
4	M holder	VNL1700
5	Screw	PBZ20P050FMC
6	Screw	PMZ20P030FMC

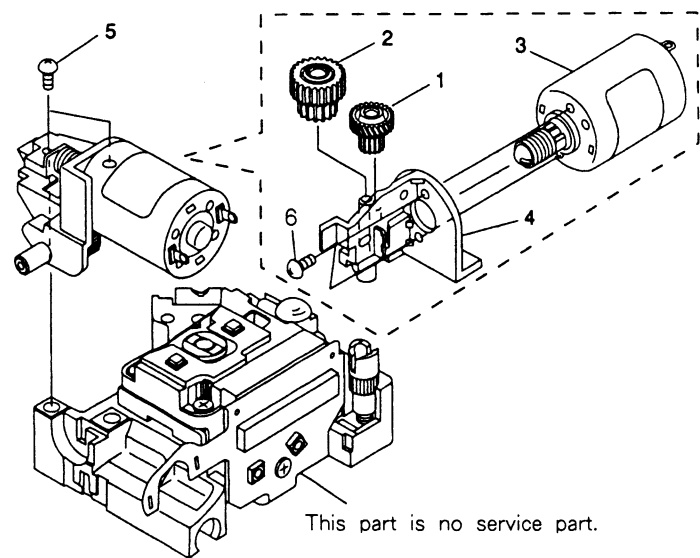

2.8 PACKING

(1) CONTRAST OF CLD - V860/KU, KC, CLD - 2750K/RD AND RDXIN.

CLD - V860/KU, KC, CLD - 2750K/RD and RDXIN have the same construction except for the following:

Mark No.	Symbol & Description	Part No.				Remarks
		CLD - V860/KU	CLD - V860/KC	CLD - 2750K/RD	CLD - 2750K/RDXIN	
NSP	1	Microphone	VPM1007	VPM1007	Not used	Not used
	2	Microphone holder	VHC1020	VHC1020	Not used	Not used
NSP	3	Soft catalog	VRY1051	Not used	Not used	Not used
	4	Operating instructions (English)	VRB1160	Not used	VRB1149	VRB1163
NSP	4	Operating instructions (English/French)	Not used	VRD1035	Not used	Not used
	5	Remote control unit	VXX2277	VXX2277	VXX2278	VXX2278
	11	Warranty card	ARY1044	ARY1039	ARW1020	ARW1020
	14	Packing case	VHG1459	VHG1459	VHG1460	VHG1510
△	16	KC label	Not used	VRW1402	Not used	Not used
	18	AC power cord	Not used	Not used	ADG1109	ADG1109

(2) PARTS LIST FOR CLD - V860/KU

Mark No.	Description	Part No.	
NSP	1	Microphone	VPM1007
NSP	2	Microphone holder	VHC1020
NSP	3	Soft catalog	VRY1051
NSP	4	Operating instructions (English)	VRB1160
NSP	5	Remote control unit	VXX2277
NSP	6	Battery cover	VNK2805
NSP	7	Polyethylene bag (205 * 315 * 0.05)	Z21 - 029
NSP	8	Video cord	DDE1090
NSP	9	Audio cord	DDE1089
NSP	10	Battery (R03, AAA)	VEM - 022
NSP	11	Warranty card	ARY1044
NSP	12	Protector L	VHB1021
NSP	13	Protector R	VHB1024
NSP	14	Packing case	VHG1459
NSP	15	Mirror mat	VHL1012
NSP	16	
NSP	17	Caution label	VRM1044
NSP	18	

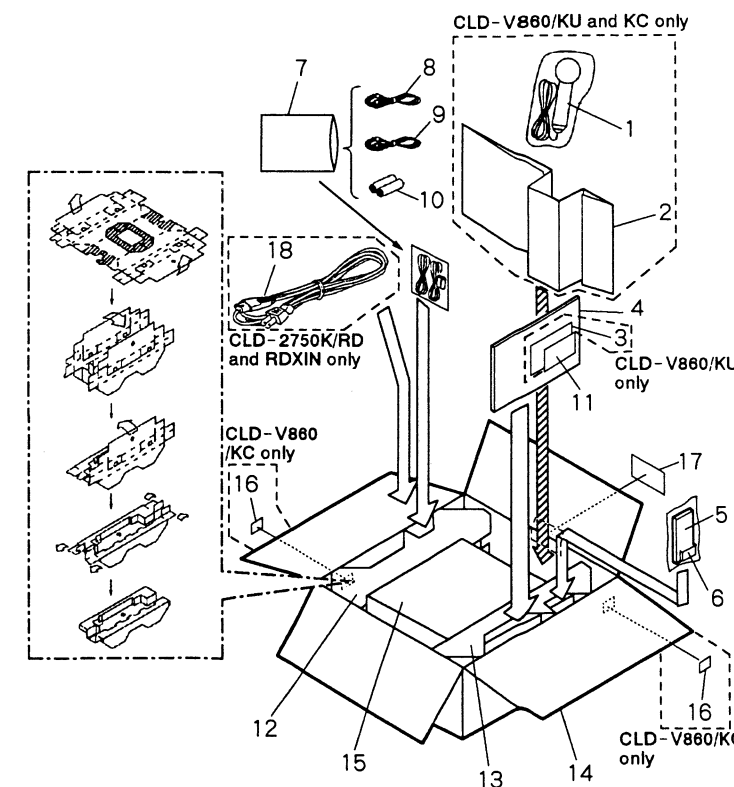

3. SCHEMATIC AND PCB CONNECTION DIAGRAMS

3.1 OVERALL CONNECTIONS, PKSB, FG, TNSB, BISB, LMSB AND CARRIAGE ASSEMBLIES

- ◆ RF SIGNAL ROUTE
- ◻ FOCUS SERVO LOOP LINE
- ◻ TRACKING SERVO LOOP LINE

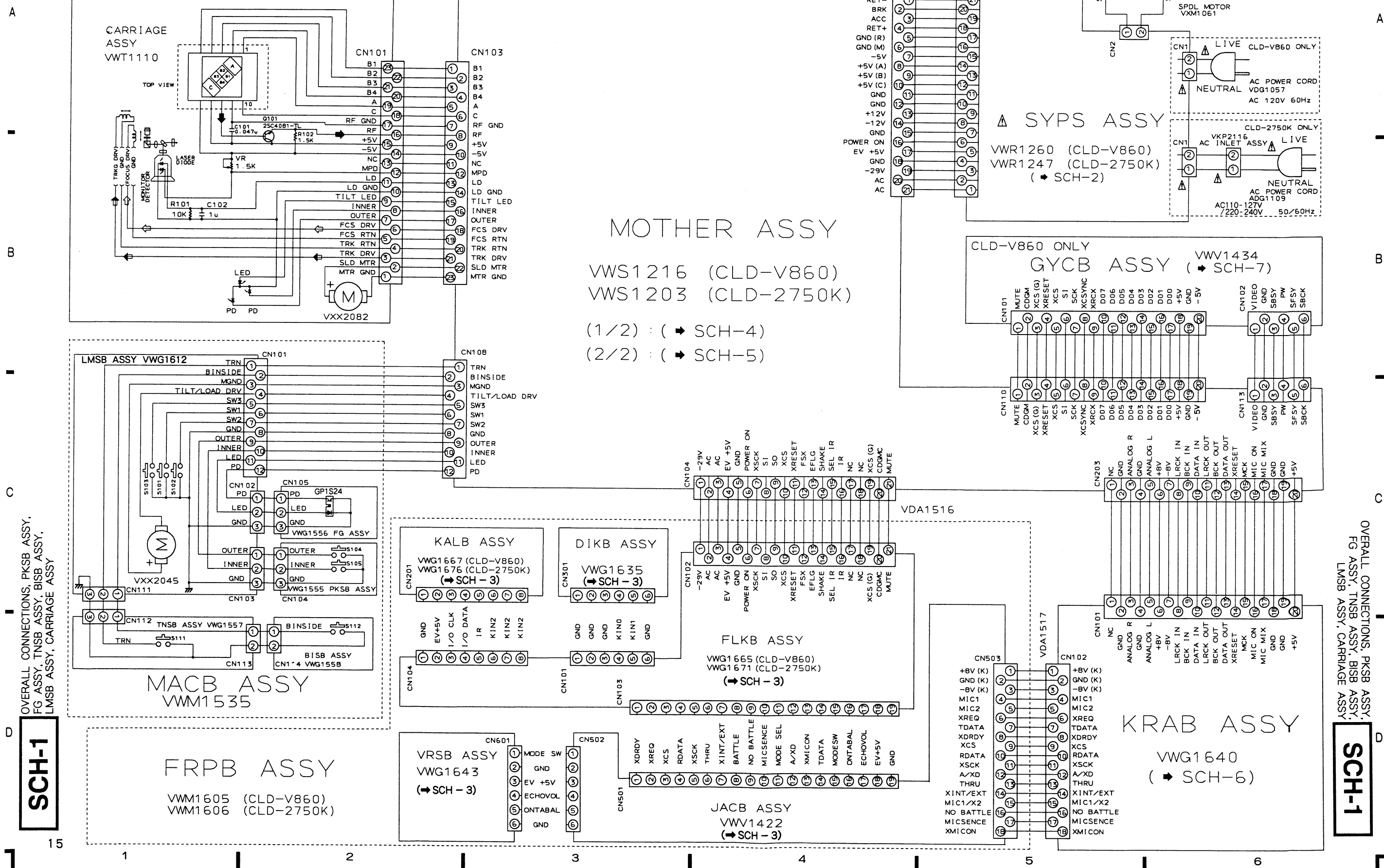

OVERALL CONNECTIONS, PKSB ASSY, FG ASSY, TNSB ASSY, BISB ASSY, LMSB ASSY, CARRIAGE ASSY

OVERALL CONNECTIONS, PKSB ASSY, FG ASSY, TNSB ASSY, BISB ASSY, LMSB ASSY, CARRIAGE ASSY

SCH-1

SCH-1

NOTE FOR SCHEMATIC DIAGRAMS (Type 4A)

1. When ordering service parts, be sure to refer to "PARTS LIST of EXPLODED VIEWS" or "PCB PARTS LIST".

2. Since these are basic circuits, some parts of them or the values of some components may be changed for improvement.

3. RESISTORS :

Unit : k : kΩ, M : MΩ, or Ω unless otherwise noted.
Rated power : 1/4W, 1/8W, 1/10W unless otherwise noted.
Tolerance : (F) : ±1%, (G) : ±2%, (K) : ±10%, (M) : ±20% or ±5% unless otherwise noted.

4. CAPACITORS :

Unit : p : pF or μF unless otherwise noted.
Ratings : capacitor (μF) / voltage (V) unless otherwise noted.
Rated voltage : 50V except for electrolytic capacitors.

5. COILS :

Unit : m : mH or μH unless otherwise noted.

6. VOLTAGE AND CURRENT :

□ or ← V :
DC voltage (V) in PLAY mode unless otherwise noted.
⇌ mA or ← mA :
DC current in PLAY mode unless otherwise noted.
Value in () is DC current in STOP mode.

7. OTHERS :

- ⊙ or ⊚ : Adjusting point.
- ◀ : Measurement point.
- The Δ mark found on some component parts indicates the importance of the safety factor of the parts. Therefore, when replacing, be sure to use parts of identical designation.

8. SCH - □ ON THE SCHEMATIC DIAGRAM :

- SCH-□ indicates the drawing number of the schematic diagram. (SCH stands for schematic diagram.)

9. SWITCHES (Underline indicates switch position) :

- | | |
|----------------------|---------------------------------|
| DIKB ASSY | LMSB ASSY |
| S301 : A } DISC SIDE | S101 : SW1 |
| S302 : B } | S102 : SW2 |
| S303 : 1 | S103 : SW3 |
| S304 : 2 | |
| S305 : 3 | PKSB ASSY |
| S306 : 4 | S104 : OUTER |
| S307 : 5 | S105 : INNER |
| S308 : 6 | |
| S309 : 7 | TNSB ASSY |
| S310 : 8 | S111 : TURN |
| S311 : 9 | |
| S312 : 10 | BISB ASSY |
| S313 : 11 | S112 : B INSIDE |
| S314 : 12 | |
| S315 : 13 | VRSB ASSY |
| S316 : 14 | S601 : NORMAL/KARAOKE/AUX INPUT |
| S317 : 15 | |

FLKB ASSY

- S101 : STOP (■)
- S102 : PLAY/PAUSE (▶ / ||)
- S103 : OPEN/CLOSE (CD ▲)
- S104 : OPEN/CLOSE (LD ▲)
- S105 : b } KEY CONTROL
- S106 : h }
- S107 : # }

KALB ASSY

- S201 : POWER STANDBY/ON
- S202 : SINGLE PLAY
- S203 : VOCAL PARTNER
- S204 : ONE-TOUCH KARAOKE
- S205 : ONE-TOUCH GUIDE VOCAL
- S206 : QUICK TURN
- S207 : GRAPHICS
- S208 : SCORING COMPETITION
- S209 : SCORING NORMAL

NOTE FOR PCB DIAGRAMS:

- Part numbers in PCB diagrams match those in the schematic diagrams.
- A comparison between the main parts of PCB and schematic diagrams is shown below.

Symbol In PCB Diagrams	Symbol In Schematic Diagrams	Part Name
		Transistor
		Transistor with resistor
		Field effect transistor
		Resistor array
		3-terminal regulator

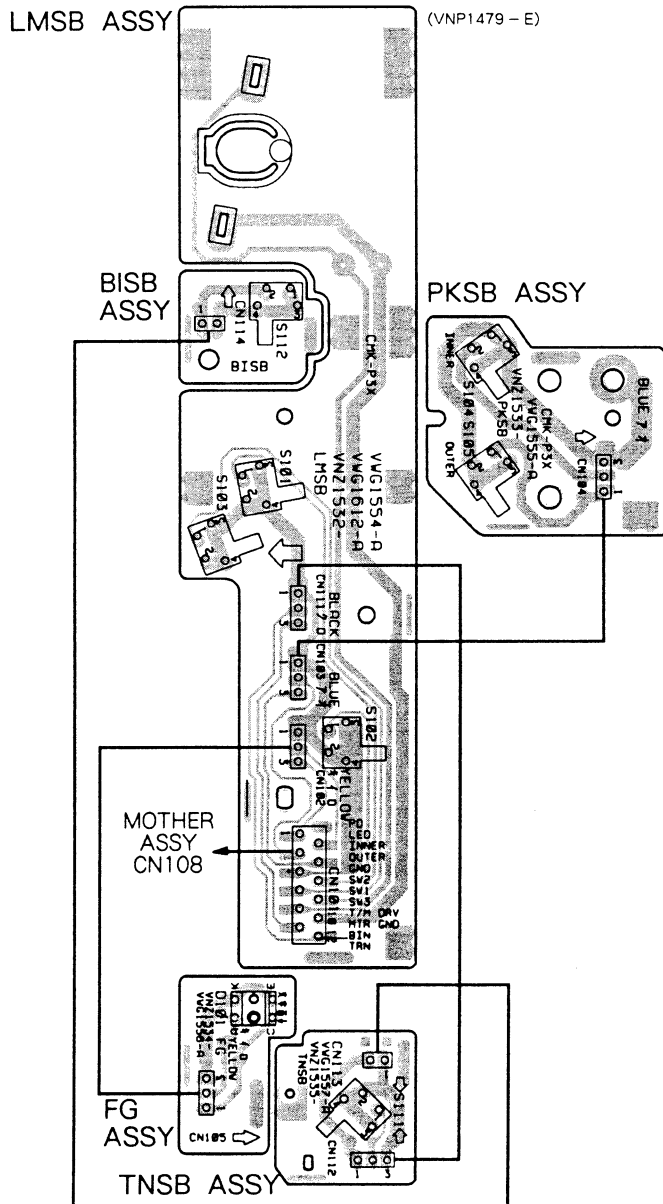

3.2 SYPS ASSY

PCB - 2

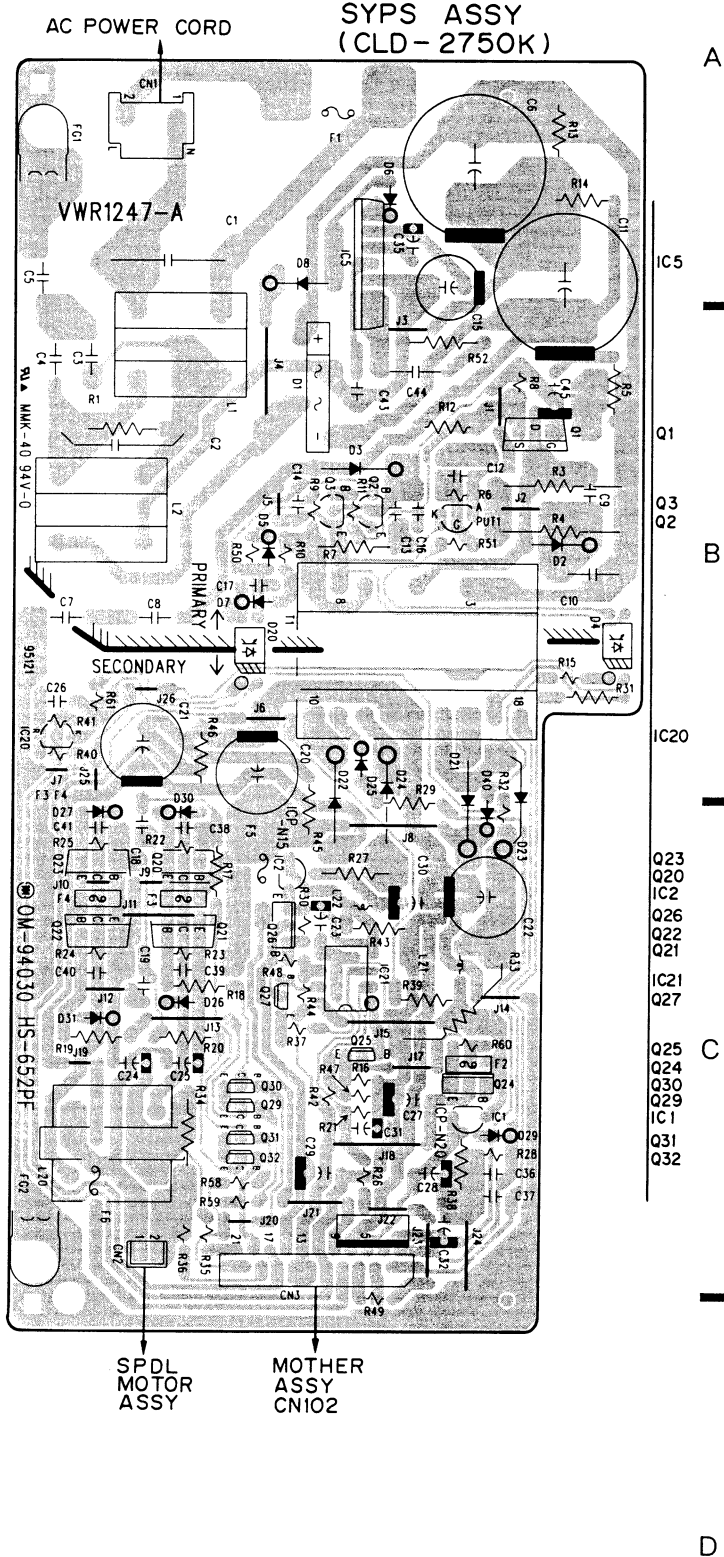
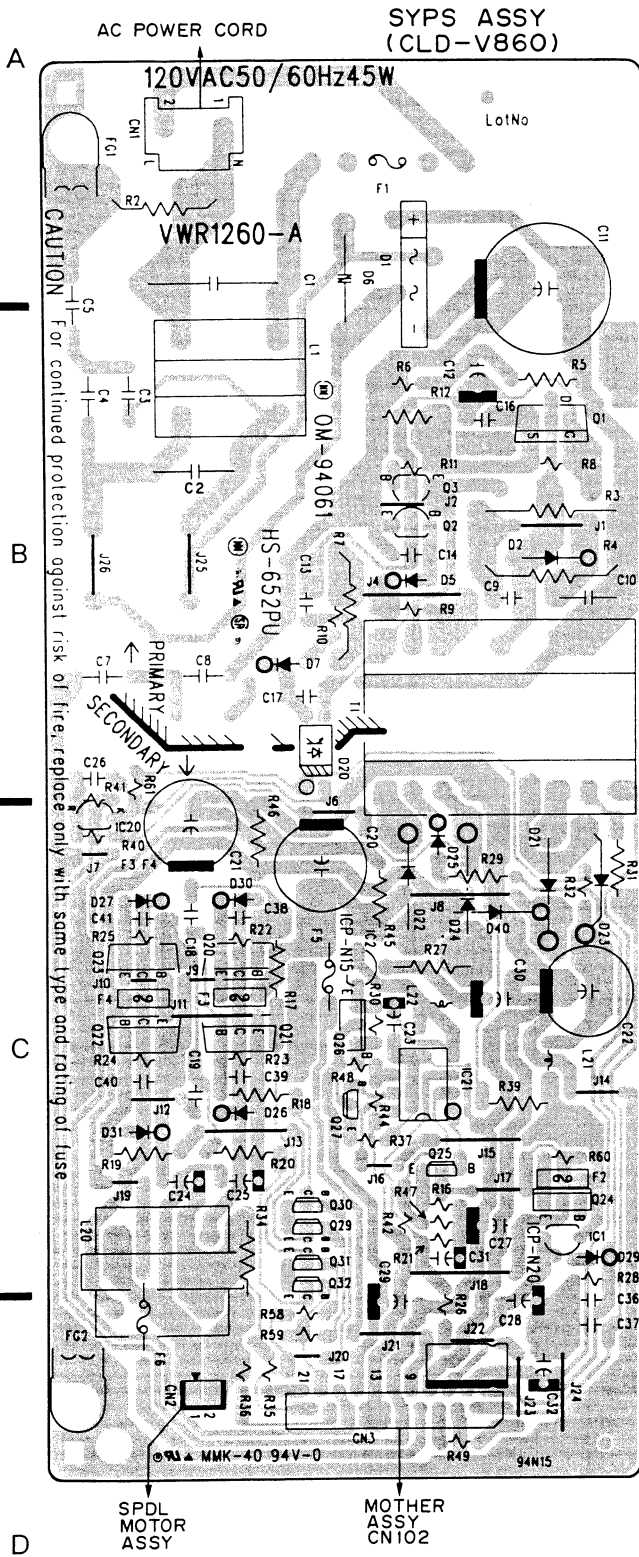

• This diagram is viewed from the mounted parts side.

● NOTE FOR FUSE REPLACEMENT
CAUTION — FOR CONTINUED PROTECTION AGAINST RISK OF FIRE,
 REPLACE ONLY WITH SAME TYPE AND RATINGS ONLY.

CAUTION: FOR CONTINUED PROTECTION AGAINST RISK OF FIRE, REPLACE ONLY WITH SAME TYPE NO. ICP-N20, BY ROHM CO., LTD. FOR IC1

CAUTION: FOR CONTINUED PROTECTION AGAINST RISK OF FIRE, REPLACE ONLY WITH SAME TYPE NO. ICP-N15, BY ROHM CO., LTD. FOR IC2

▲ SYPS ASSY
 VWR1260 (CLD-V860)
 VWR1247 (CLD-2750K)

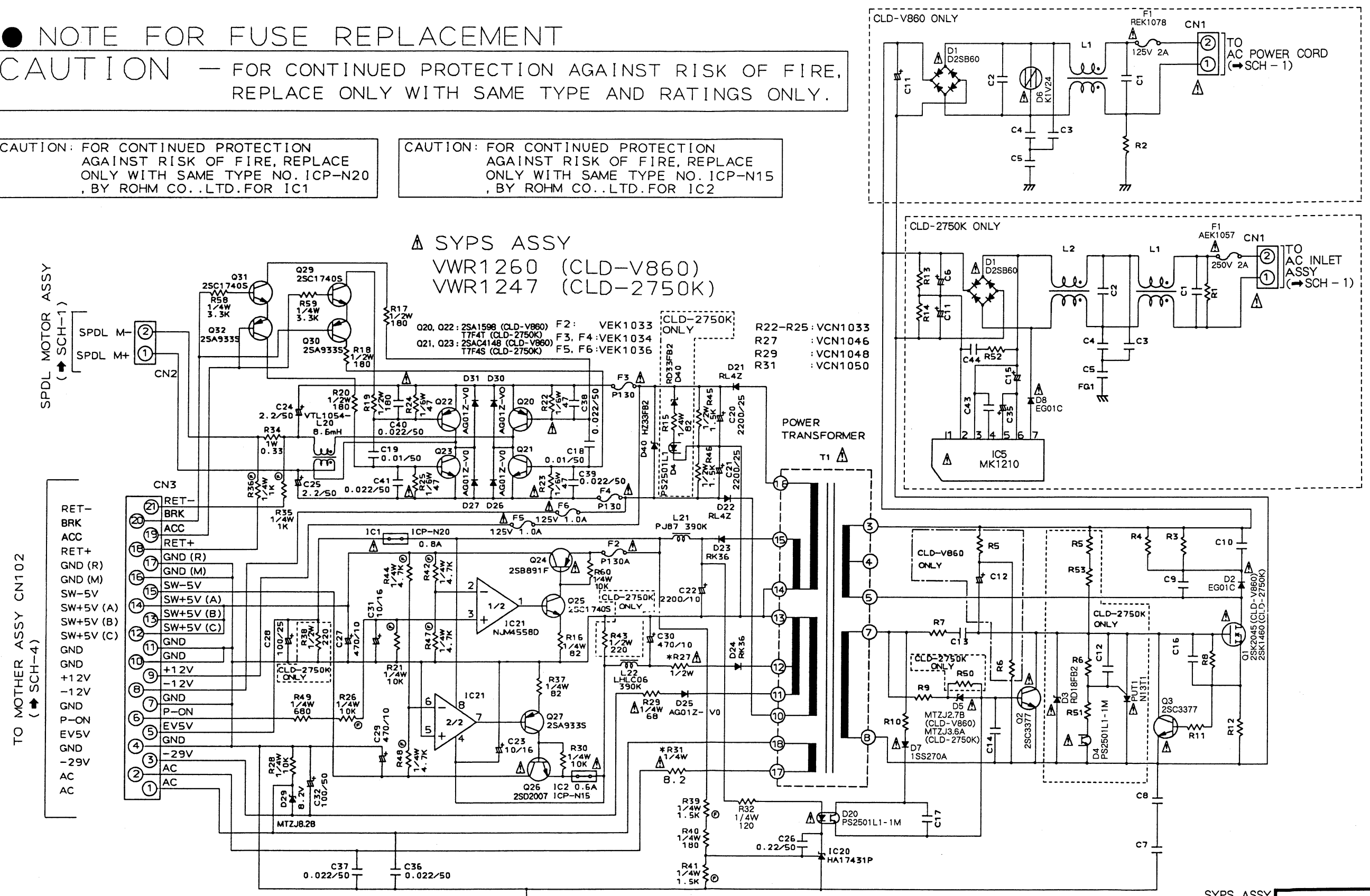

TO MOTHER ASSY CN102
 (→ SCH-4)

- RET- (21)
- BRK (20)
- ACC (19)
- RET+ (18)
- GND (R) (17)
- GND (M) (16)
- SW-5V (15)
- SW+5V (A) (14)
- SW+5V (B) (13)
- SW+5V (C) (12)
- GND (11)
- +12V (10)
- 12V (9)
- GND (8)
- P-ON (7)
- EV5V (6)
- GND (5)
- 29V (4)
- AC (3)
- AC (2)

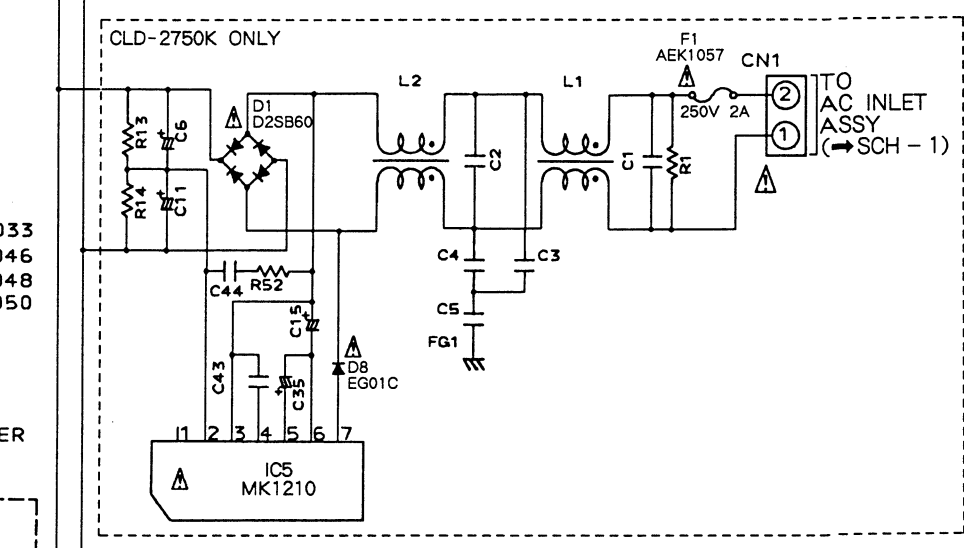
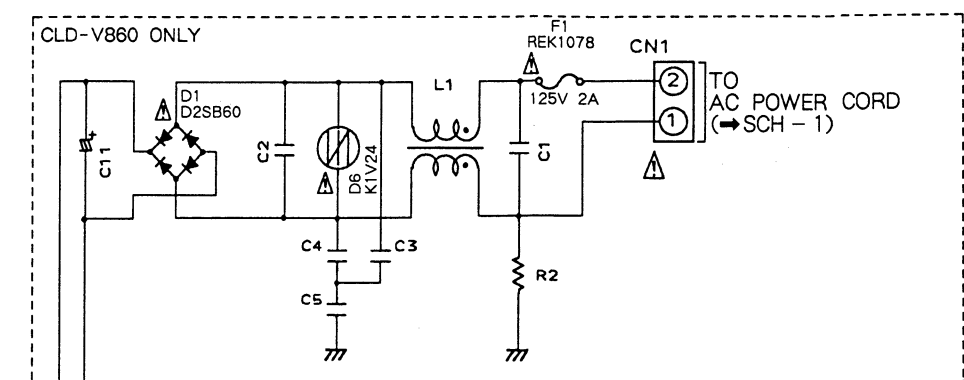

3.3 DIKB, VRSB, FLKB, KALB AND JACB ASSEMBLIES

DIKB ASSY VWG1635

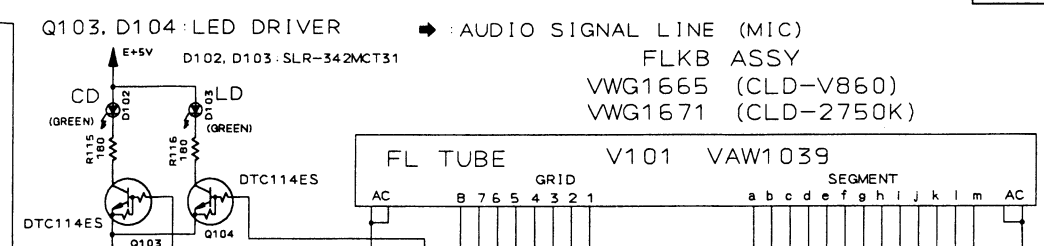
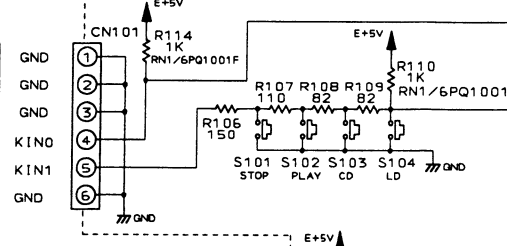
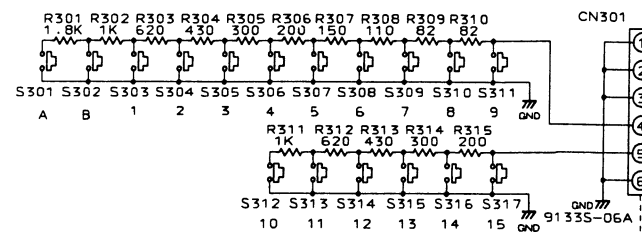

SCH-3

TO KRAB ASSY CN102 (SCH-6)

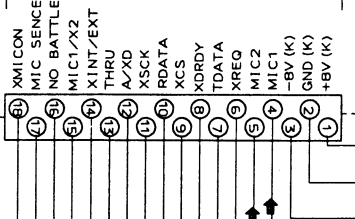

TO MOTHER ASSY CN104 (SCH-4)

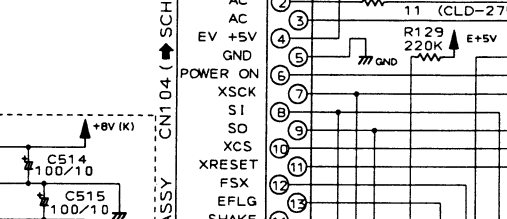

JACB ASSY
VWV1422

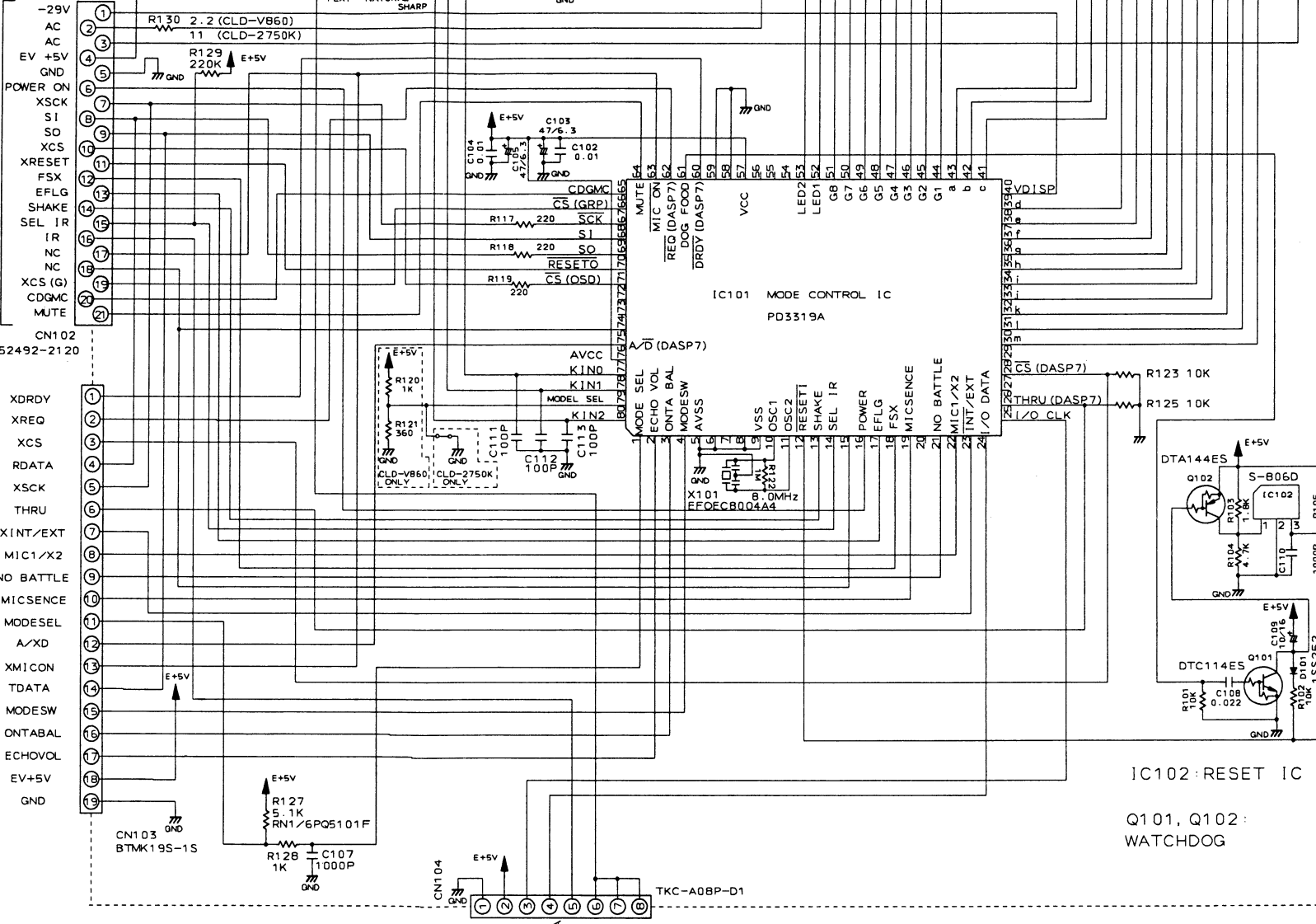
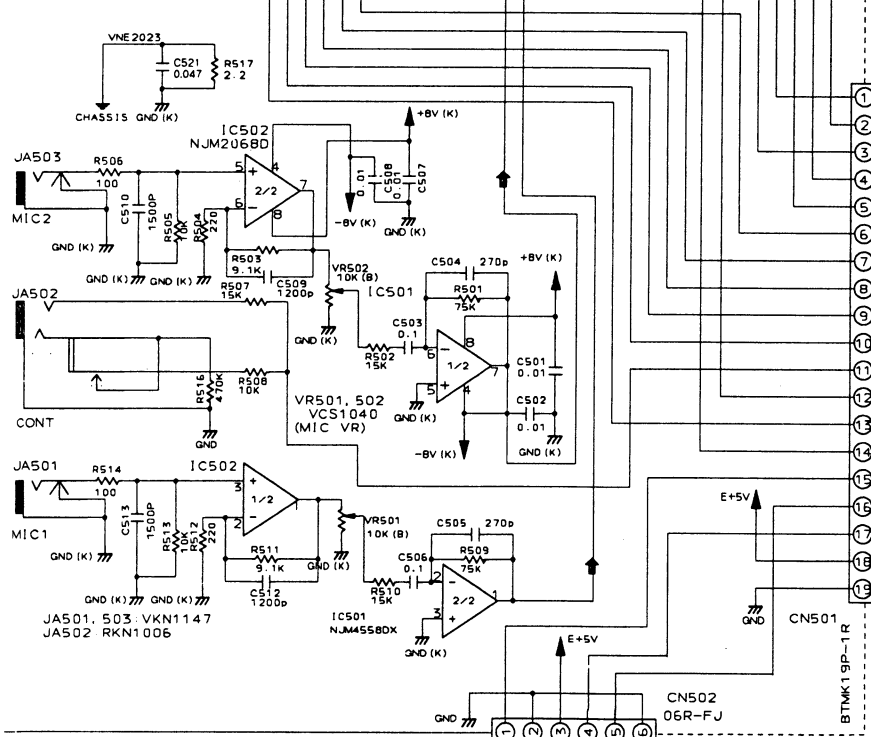

VRSB ASSY
VWG1643

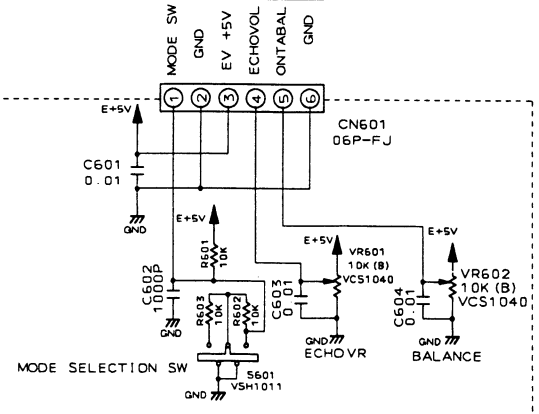

KALB ASSY
VWG1667 (CLD-V860)
VWG1676 (CLD-2750K)

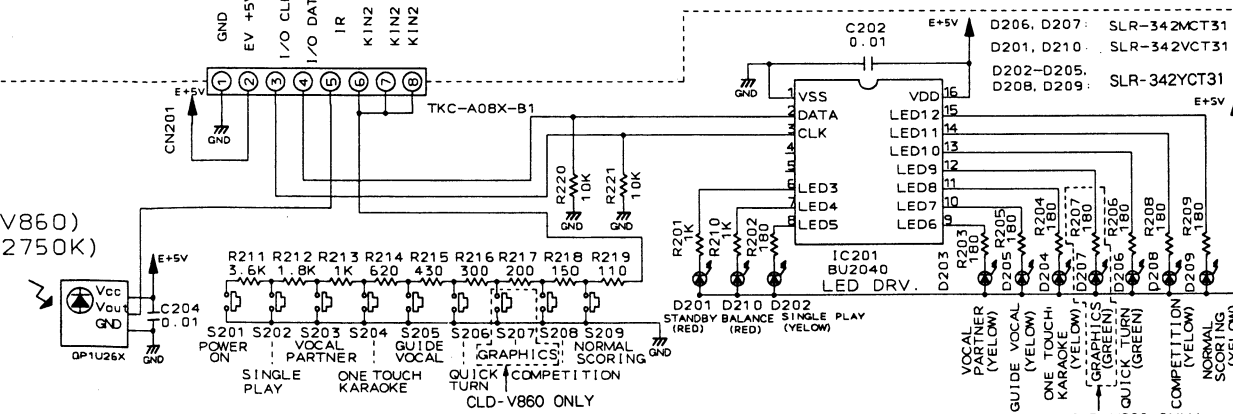

DIKB ASSY, VRSB ASSY, FLKB ASSY,
KALB ASSY, JACB ASSY

SCH-3

SCH-3

VAW1039 (FLKB ASSY V101)

FL TUBE

ANODE GRID ASSIGNMENT & PIN ASSIGNMENT

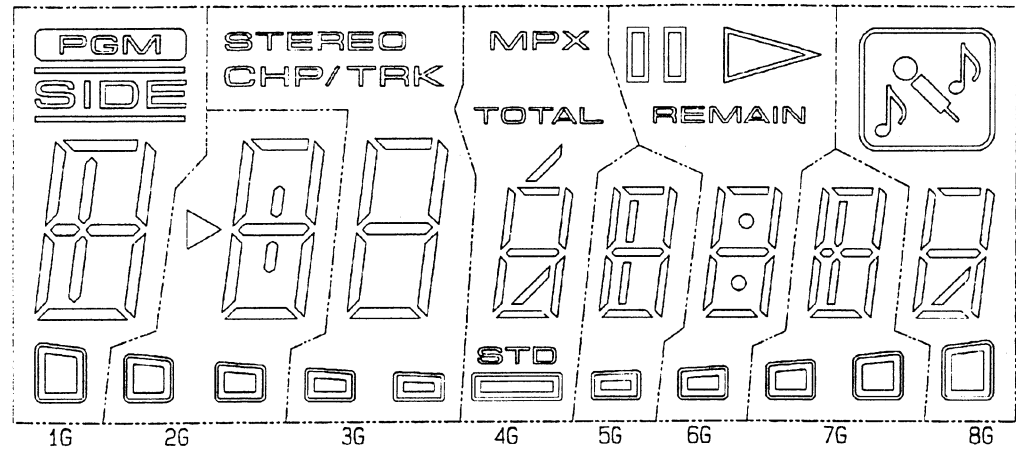

ANODE GRID ASSIGNMENT

	G1	G2	G3	G4	G5	G6	G7	G8
S1	a	a	a	a	a	a	a	a
S2	b	b	b	b	b	b	b	b
S3	c	c	c	c	c	c	c	c
S4	d	d	d	d	d	d	d	d
S5	e	e	e	e	e	e	e	e
S6	f	f	f	f	f	f	f	f
S7	-	g	g	g	g	g	•	g
S8	-	!	STEREO (上)	/	!	:	-	/
S9	!	>	CHP/TRK (下)	/	/		!	!
S10	PGM	(右) □	(右) □	MPX	/	▷	(右) □	/
S11	SIDE	(左) □	(左) □	TOTAL	/	REMAIN	(左) □	/
S12	□	(右) □	(右) □	STD	□	□	(右) □	□
S13	□	(左) □	(左) □	□	□	□	(左) □	□

PIN ASSIGNMENT

Pin No.	1	2	3	4	5	6	7	8	9	10
Assignment	F	F	NP	S13	S12	S11	S10	S9	S8	S7
Pin No.	11	12	13	14	15	16	17	18	19	20
Assignment	S6	S5	S4	S3	S2	S1	G1	G2	G3	G4
Pin No.	21	22	23	24	25	26	27			
Assignment	G5	G6	G7	G8	NP	F	F			

F:Filament G1~G8:Grid S1~S13:Anode NP:No pin

DIKB ASSY

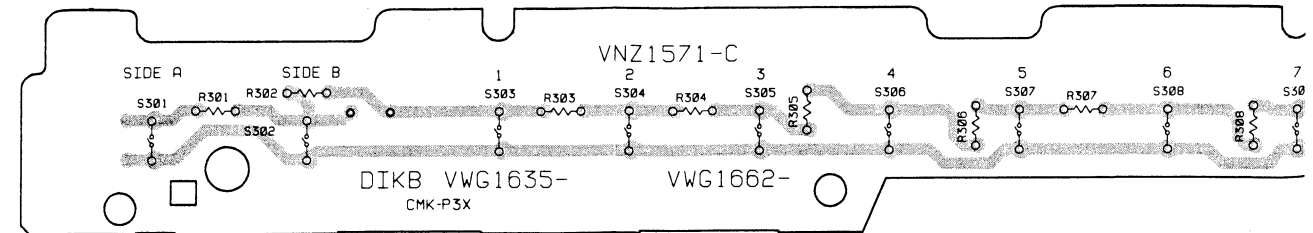

KALB ASSY

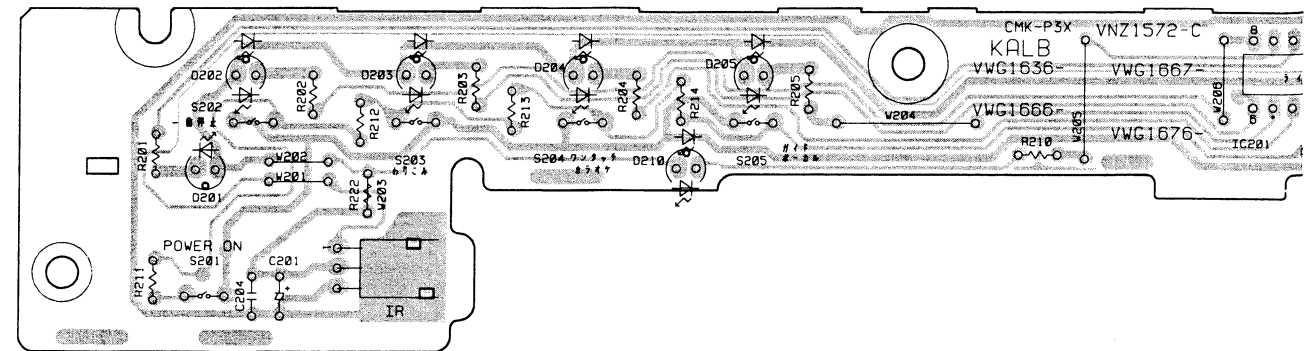

VRSB ASSY

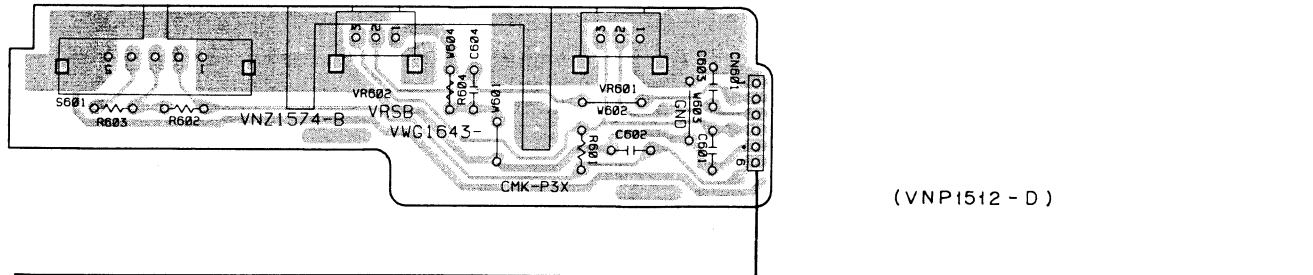

JACB ASSY

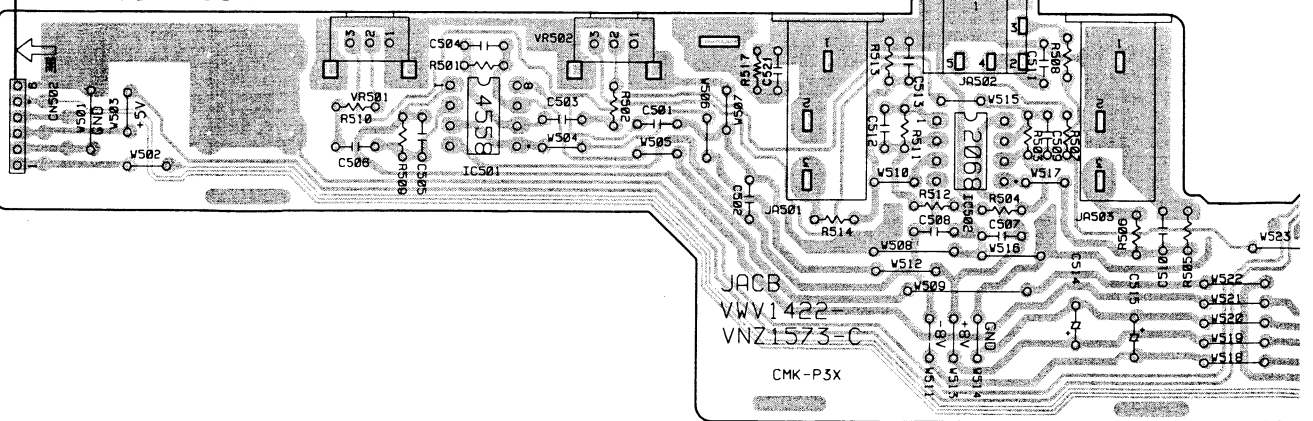

This diagram is viewed from the mc

DIKB ASSY

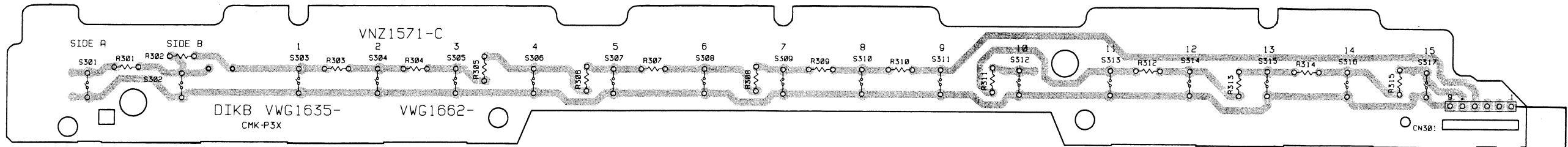

KALB ASSY

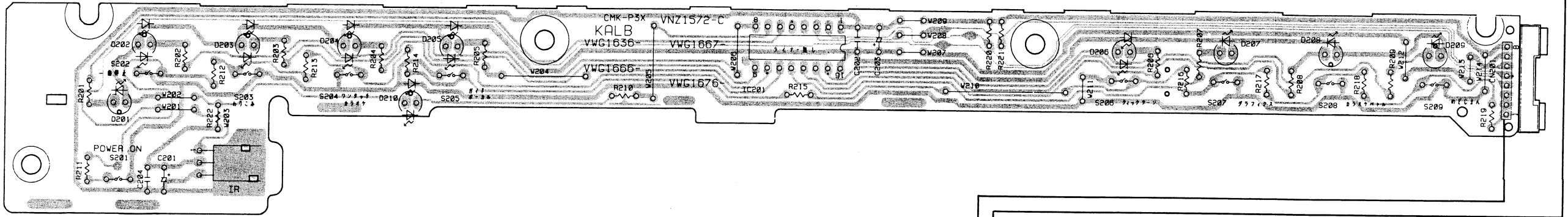

VRSB ASSY

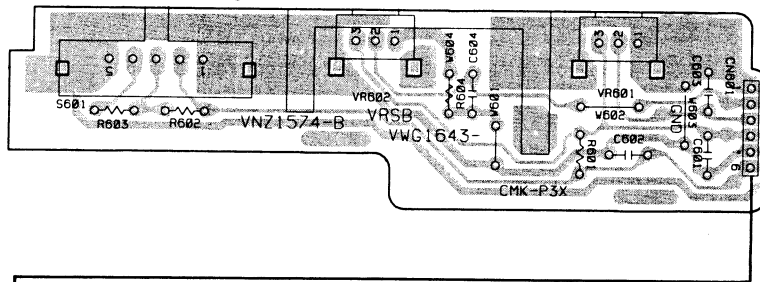

(VNPI512 - D)

JACB ASSY

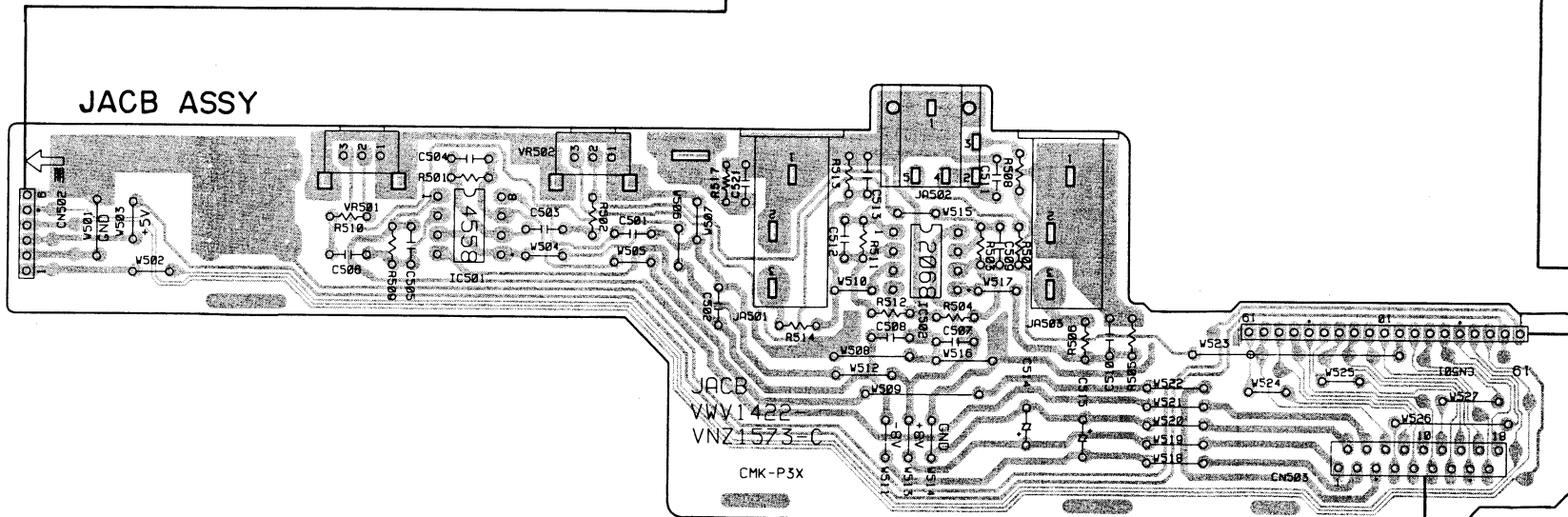

KRAB ASSY
CN 102

FLKB ASSY

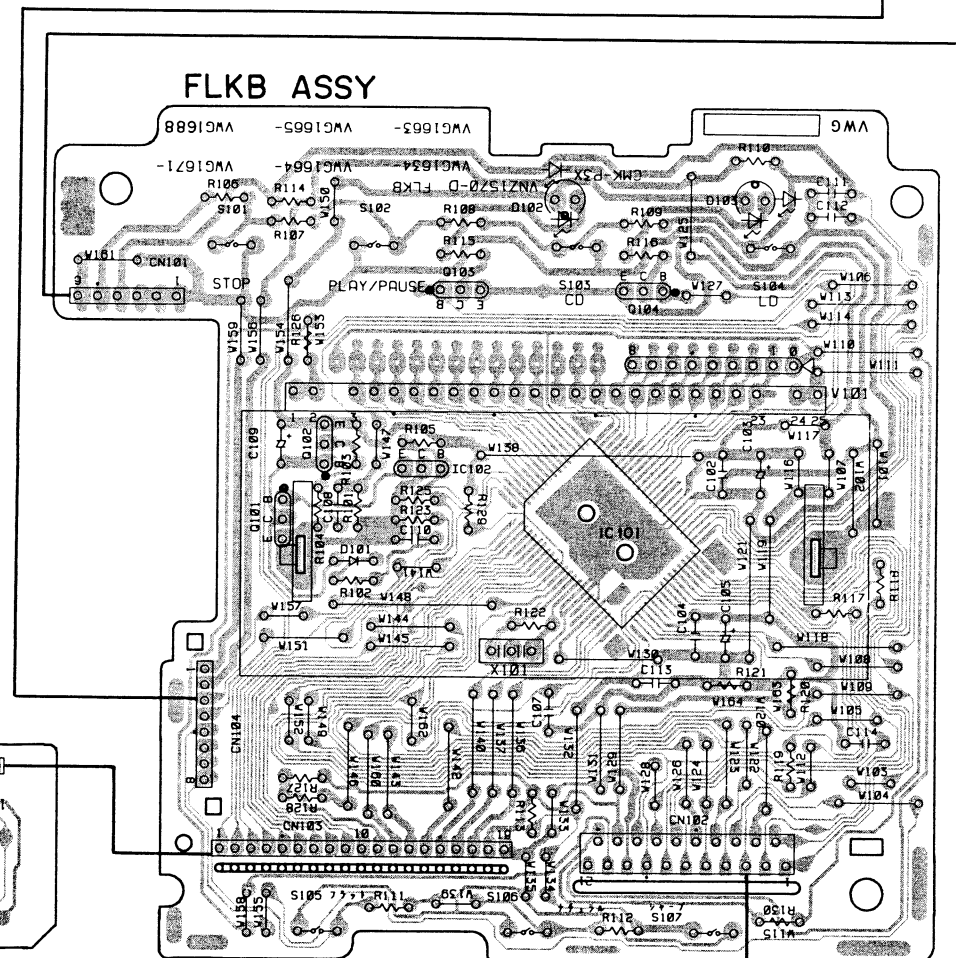

MOTHER ASSY
CN 104

• This diagram is viewed from the mounted parts side.

• The parts mounted on this PCB include all necessary parts for several destinations. For further information for respective destinations, be sure to check with the schematic diagram.

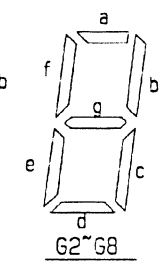

A

B

C

D

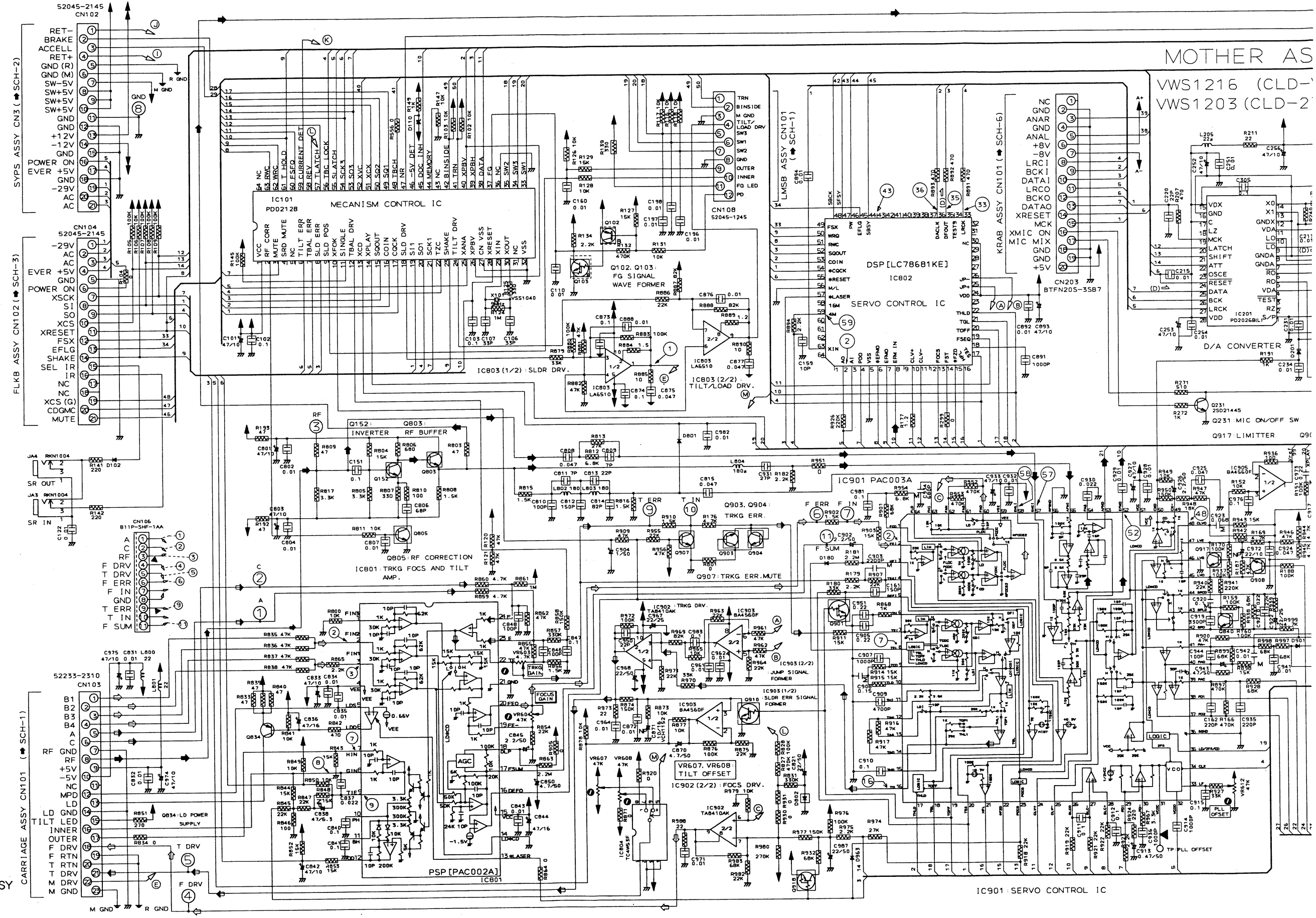

SCH-4

MOTHER ASSY (1/2)

SCH-4

TO MOTHER ASSY (2/2)
(SCH-5)

MOTHER ASSY

VWS1216 (CLD-V860)
VWS1203 (CLD-2750K)

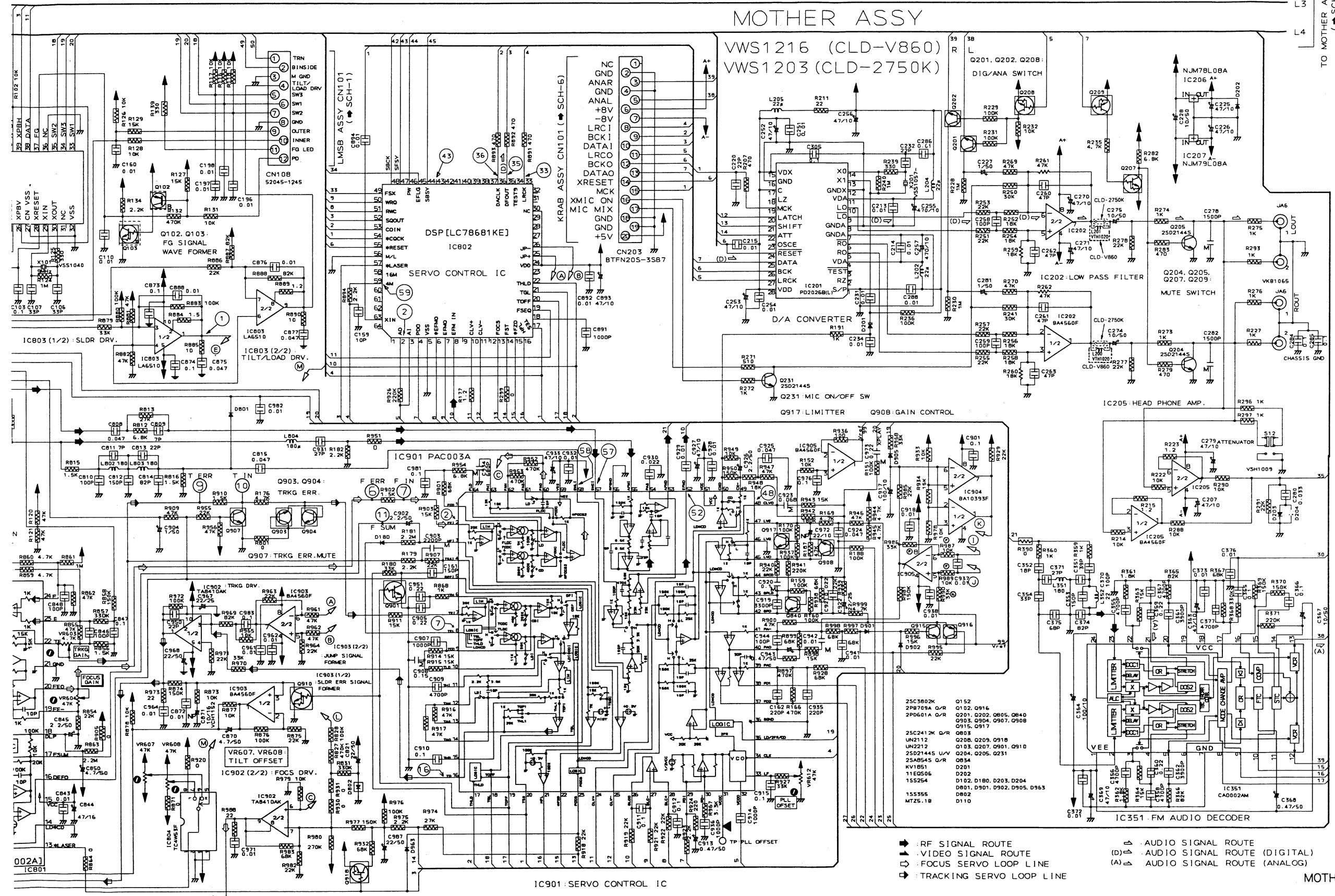

- RF SIGNAL ROUTE
- VIDEO SIGNAL ROUTE
- FOCUS SERVO LOOP LINE
- TRACKING SERVO LOOP LINE
- AUDIO SIGNAL ROUTE
- (D) — AUDIO SIGNAL ROUTE (DIGITAL)
- (A) — AUDIO SIGNAL ROUTE (ANALOG)

25C380K	Q152
2P8709A Q/R	Q102, Q916
2PD601A Q/R	Q201, Q202, Q805, Q840
	Q903, Q904, Q907, Q908
	Q915, Q917
25C2412K Q/R	Q803
UN2112	Q208, Q209, Q918
UN2212	Q103, Q207, Q901, Q910
25D21445 U/A	Q204, Q205, Q231
25A8545 Q/R	Q834
KV1851	D201
11E0506	D202
155254	D102, D180, D203, D204
	D801, D901, D902, D905, D963
155555	D802
MTZ5-18	D110

MOTHER ASSY (1/2)

SCH-4

3.5 MOTHER ASSY (2/2)

MOTHER ASSY
VWS1216 (CLD-V860)
VWS1203 (CLD-2750K)

SCH-5

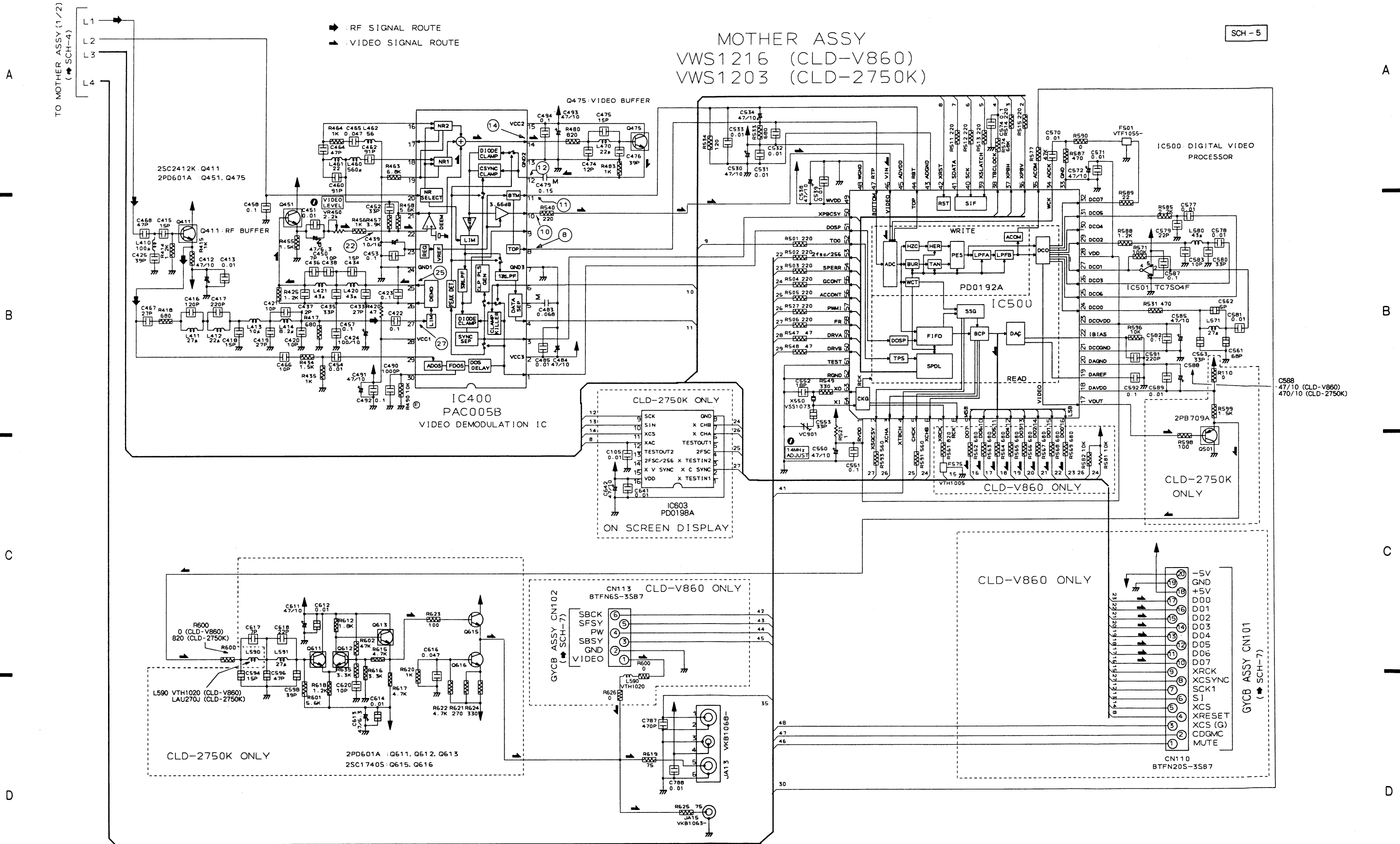

SCH-5 MOTHER ASSY (2/2)

MOTHER ASSY (2/2) **SCH-5**

**WAVEFORMS AND VOLTAGE
MOTHER ASSY**

Note : (No.) in the table correspond to the pin number.

Measurement condition : In case when (D. audio) is written, at time when disc that has digital audio recording is played.

IC801(PAC002A)	IC802(LC78681KE)	IC803(LA6510)	IC901(PAC003A)	CN106	IC400 (PAC005B)
(2), (3) 1mS/Div. 16mVp-p AC mode	(2) 0.1μS/Div. 4.3Vp-p AC mode(D.audio)	(1) 2mS/Div. 1.8Vp-p DC mode	(2) 0.2mS/Div. 74mVp-p DC mode	(1), (2) 5mS/Div. 65mVp-p DC mode	(14) 1.52Vp-p 0.55V V: 20mV/Div H: 10mS/Div
(7), (8) 1mS/Div. 67mVp-p DC mode	(33) 10μS/Div. 4.2Vp-p AC mode(D.audio)		(7) 0.2mS/Div. 74mVp-p DC mode	(3) 0.5mS/Div. 300mVp-p AC mode	(8) (TOP) -2.4V (11) (BOTTOM) 1.85V 0.55V
(9) 5mS/Div. 0.1Vp-p DC mode	(35) 0.2μS/Div. 4.4Vp-p AC mode(D.audio)		(16) 0.2mS/Div. 0.61Vp-p DC mode	(4) 5mS/Div. 15Vp-p DC mode	(12) 1Vp-p 1.65V V: 20mV/Div H: 10mS/Div
	(36) 0.2μS/Div. 4.5Vp-p AC mode(D.audio)		(48) 50μS/Div. 6.2Vp-p DC mode	(5) 5mS/Div. 5.8Vp-p DC mode	(14) 1Vp-p V: 20mV/Div H: 10mS/Div
	(43) 0.1μS/Div. 4.5Vp-p AC mode(D.audio)		(52) 0.2μS/Div. 2.1Vp-p AC mode	(6) 5mS/Div. 3.5Vp-p DC mode	(22) (No noise) (25) (With limiter noise) V: 20mV/Div Approx. H: 10mS/Div 330mVp-p
	(59) 0.1μS/Div. 2Vp-p AC mode(D.audio)		(57) 1mS/Div. 0.53Vp-p DC mode	(9) 5mS/Div. 1.25Vp-p DC mode	(27) Approx. 1Vp-p 0.5mS/Div
			(58) 0.2mS/Div. 0.32Vp-p DC mode	(11) 10mS/Div. 1.7Vp-p DC mode	

• The inside block diagram of IC901 (PAC003A)

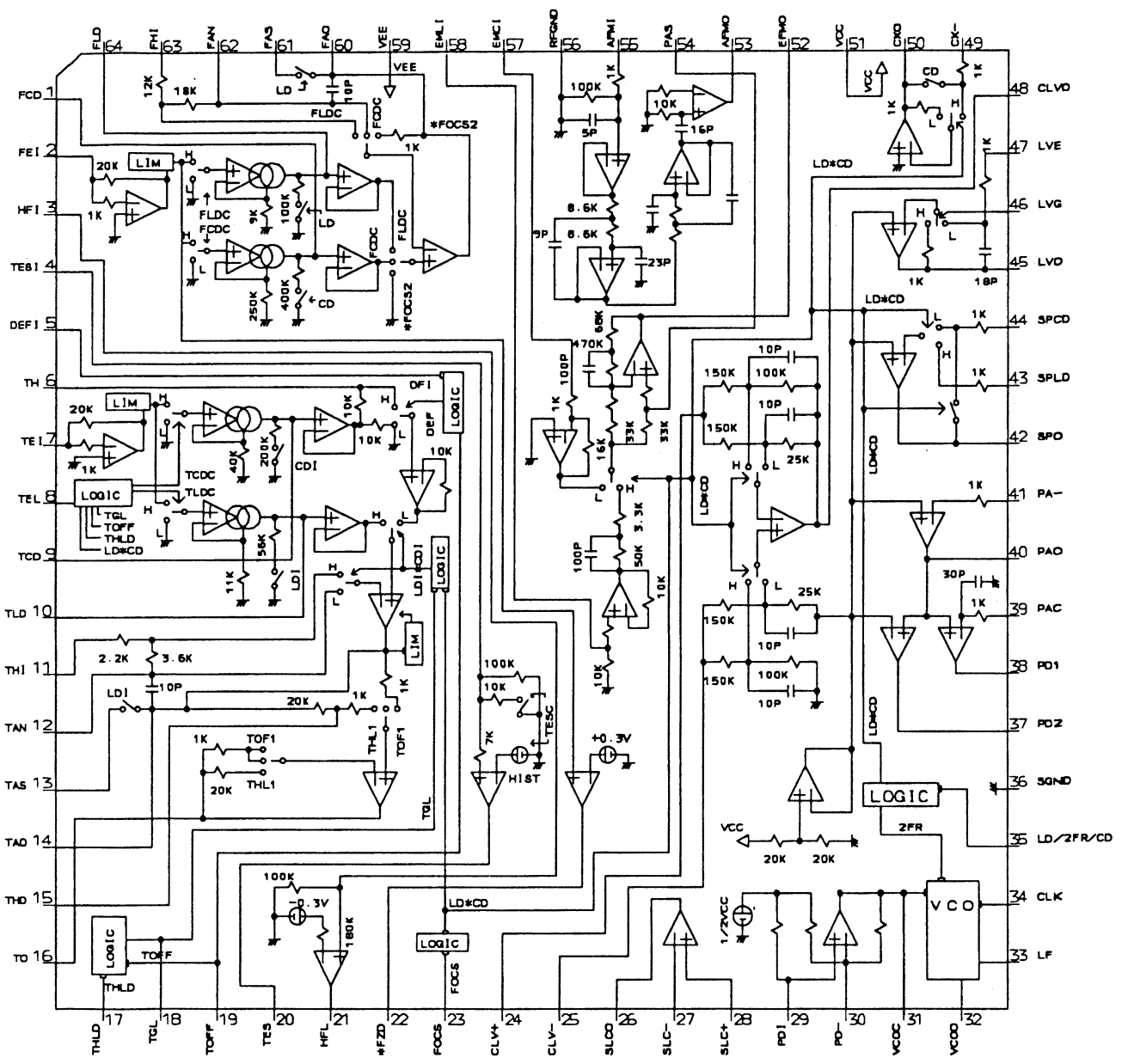

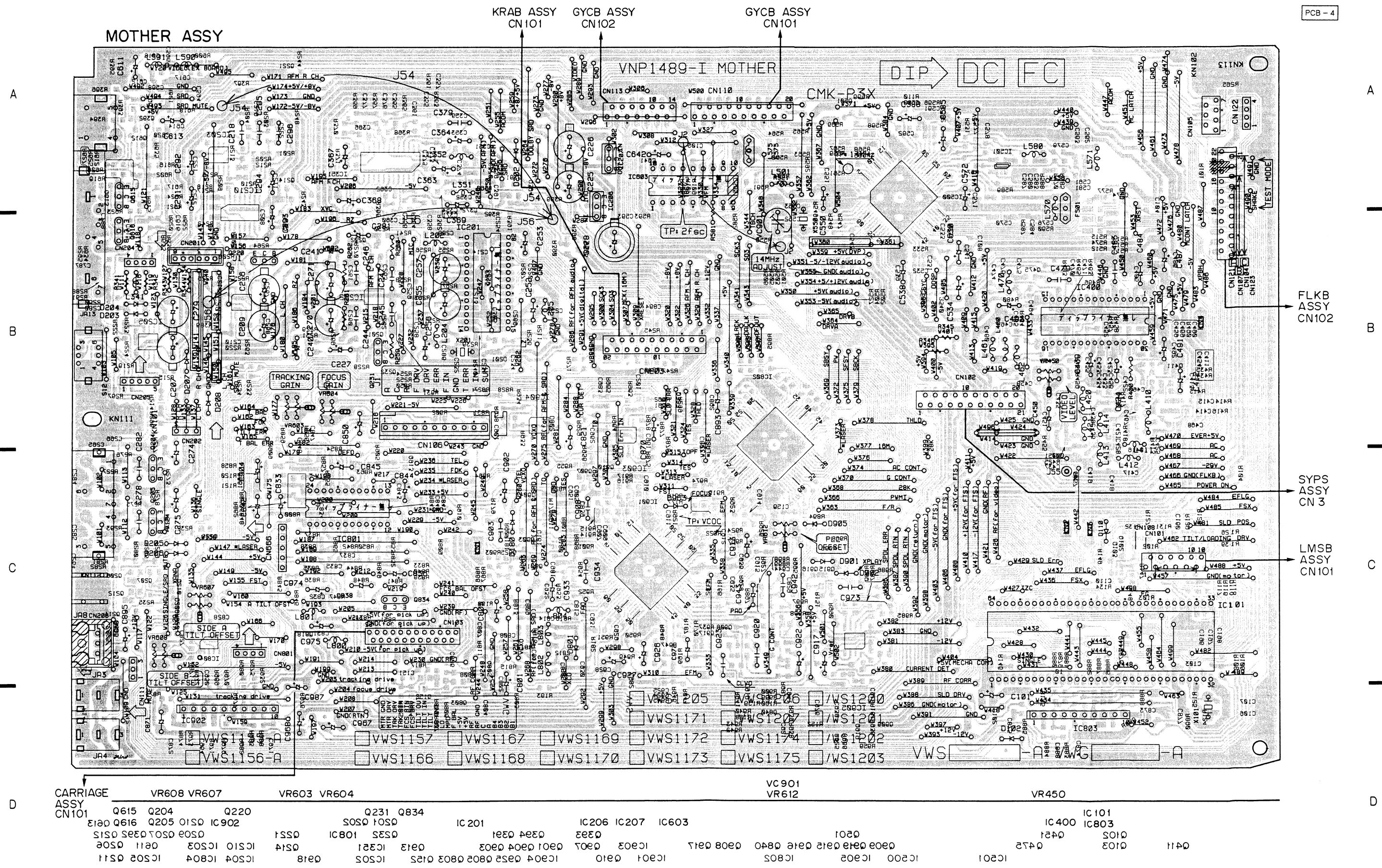

• This diagram is viewed from the mounted parts side.

• The parts mounted on this PCB include all necessary parts for several destinations. For further information for respective destinations, be sure to check with the schematic diagram.

KRAB ASSY
VWG1640

SCH - 6

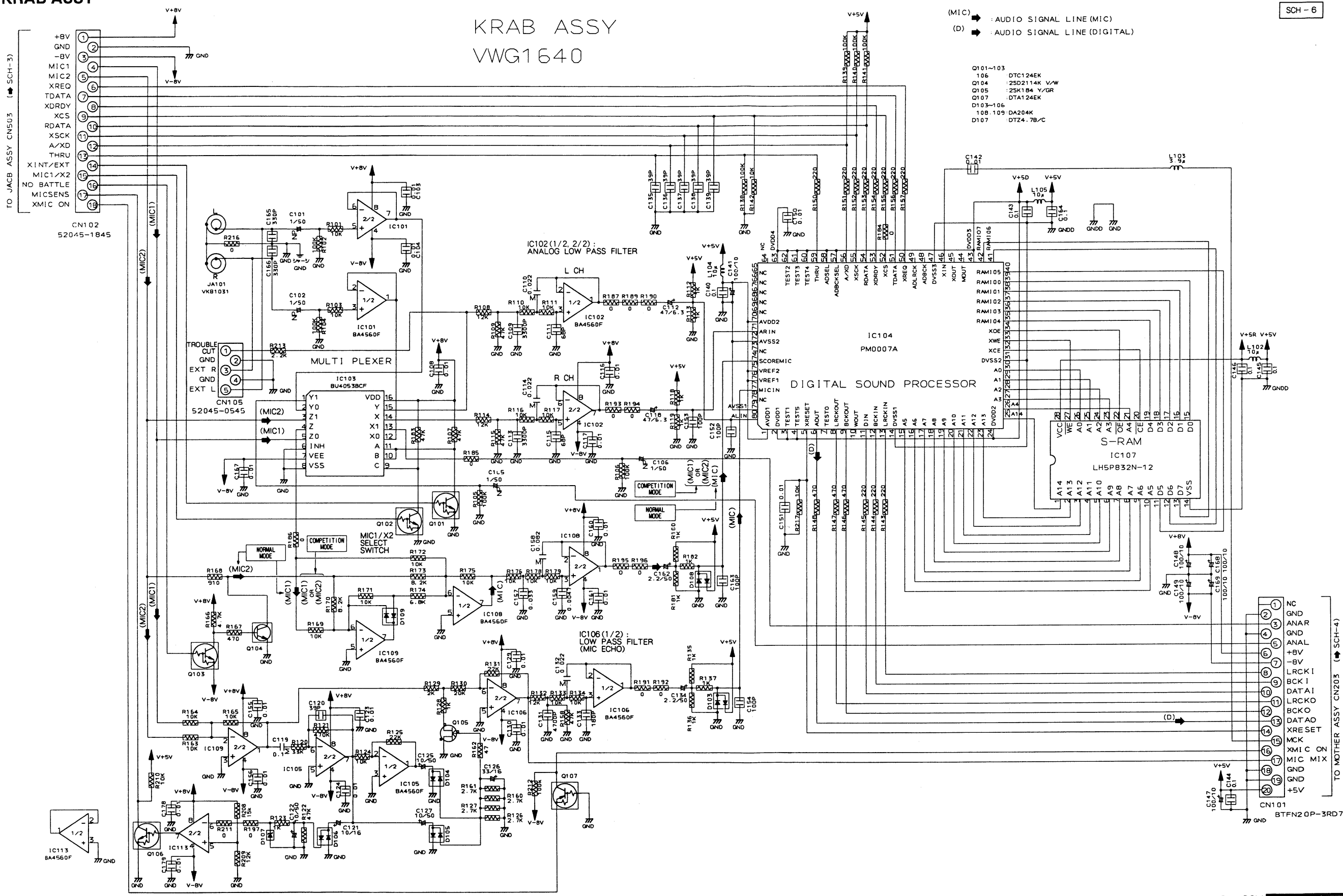

(MIC) → AUDIO SIGNAL LINE (MIC)
 (D) → AUDIO SIGNAL LINE (DIGITAL)

- Q101-103 : DTC124EK
- Q104 : 2SD2114K V/W
- Q105 : 2SK184 V/GR
- Q107 : DTA124EK
- D103-106 : DA204K
- D107 : DTZ4.7B/C

A
B
C
D

SCH-6 KRAB ASSY

KRAB ASSY SCH-6

KRAB ASSY

MOTHER
ASSY
CN203

JACB
ASSY
CN503

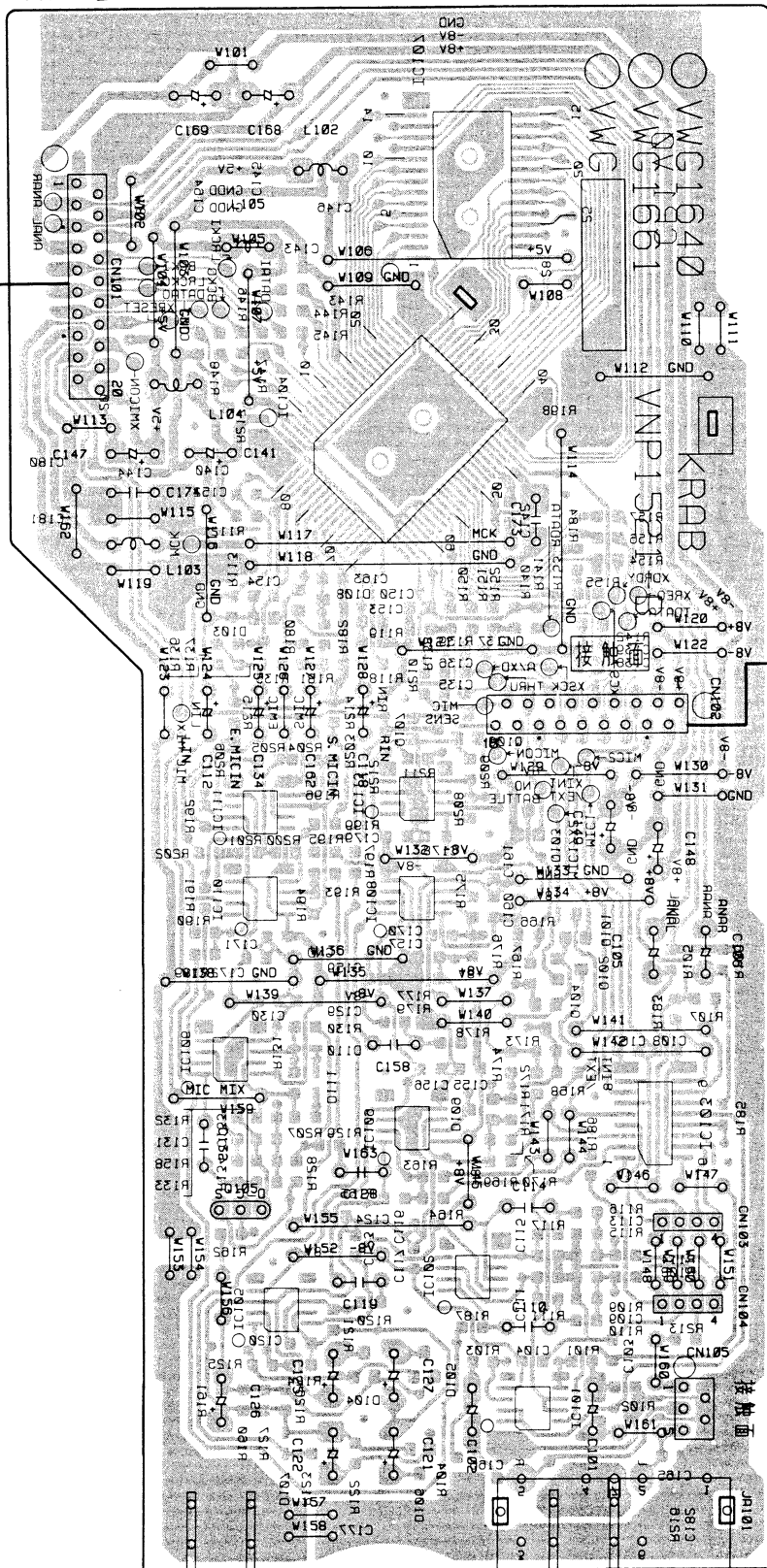

- IC105
- IC104
- IC103
- IC102
- IC101
- IC105
- IC104
- IC103
- IC102
- IC101
- IC105
- IC104
- IC103
- IC102
- IC101

- This diagram is viewed from the mounted parts side.
- The parts mounted on this PCB include all necessary parts for several destinations.
For further information for respective destinations, be sure to check with the schematic diagram.



3.7 GYCB ASSY

GYCB ASSY

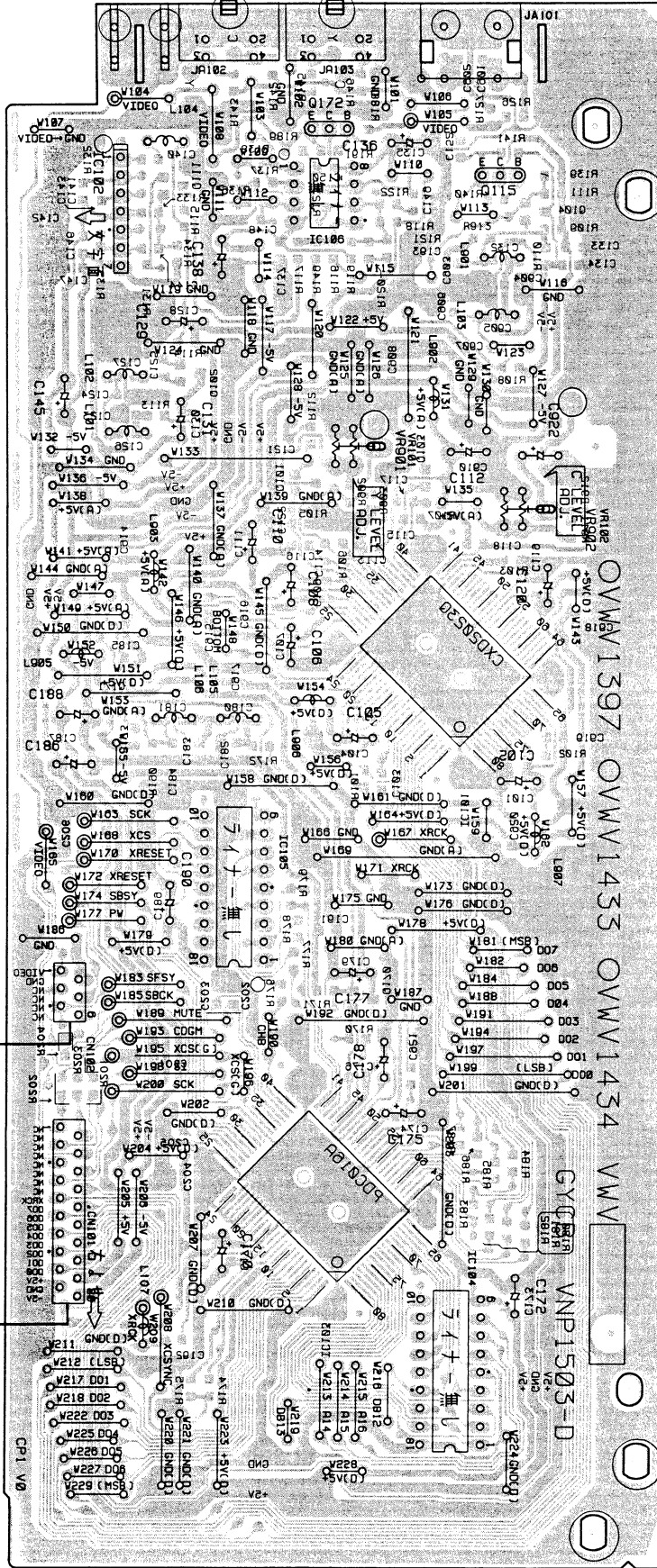

MOTHER ASSY
CN113

MOTHER ASSY
CN110

Q172
Q115
P010
IC106
IC102

S010
VR101
VR901
VR102
VR902

IC101
Q110

IC105

Q110

IC103

IC104

- This diagram is viewed from the mounted parts side.
- The parts mounted on this PCB include all necessary parts for several destinations.
For further information for respective destinations, be sure to check with the schematic diagram.

GYCB ASSY
VWV1434

▶ VIDEO SIGNAL ROUTE

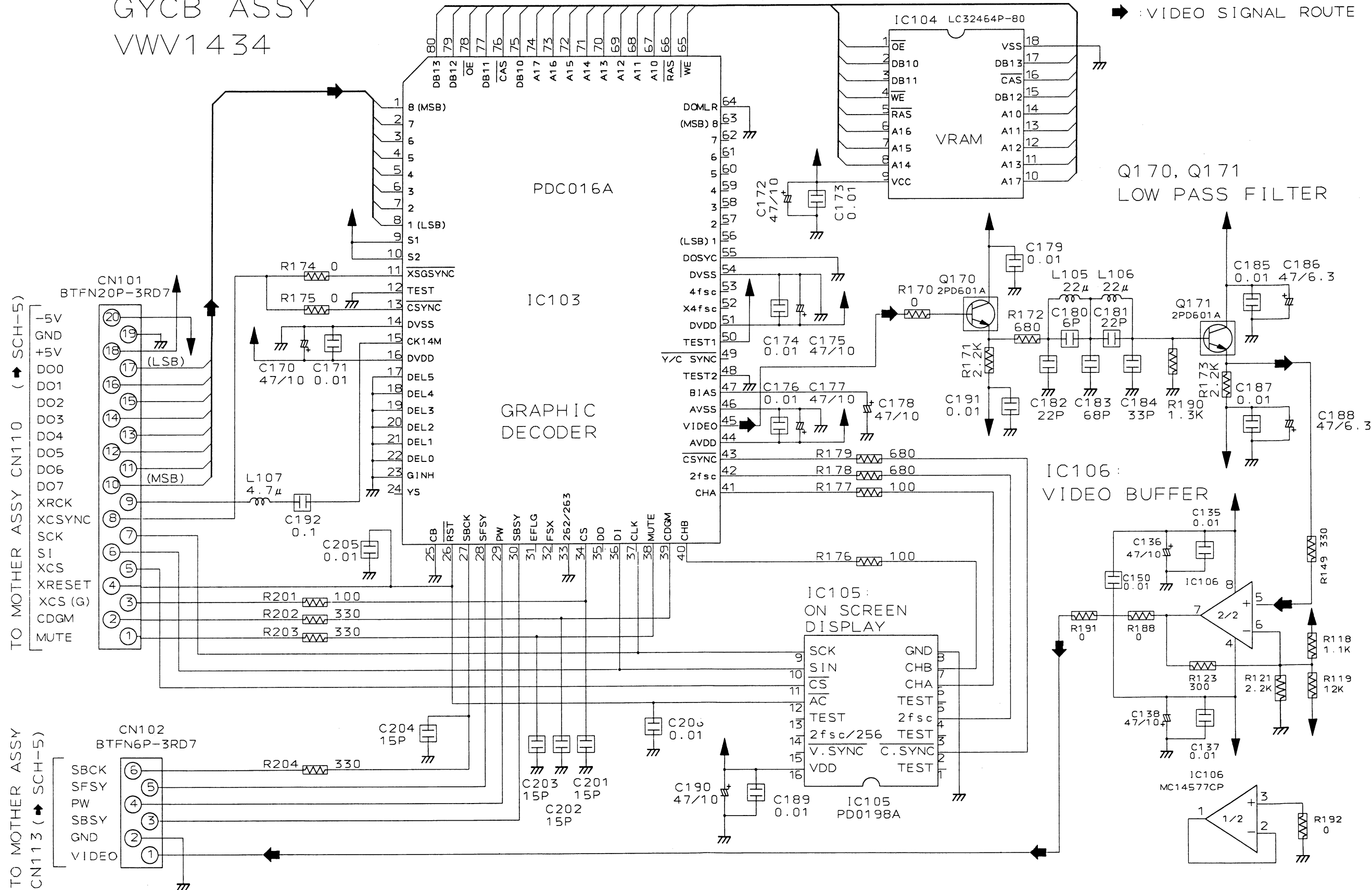

4. PCB PARTS LIST

- NOTES:
- Parts marked by "NSP" are generally unavailable because they are not in our Master Spare Parts List.
 - The Δ mark found on some component parts indicates the importance of the safety factor of the part. Therefore, when replacing, be sure to use parts of identical designation.
 - Parts marked by "⊙" are not always kept in stock. Their delivery time may be longer than usual or they may be unavailable.
 - When ordering resistors, first convert resistance values into code form as shown in the following examples.
- Ex.1 When there are 2 effective digits (any digit apart from 0), such as 560 ohm and 47k ohm (tolerance is shown by J=5%, and K=10%).
- 560 Ω \rightarrow 56 \times 10¹ \rightarrow 561 RD1/8PM561J
 47k Ω \rightarrow 47 \times 10³ \rightarrow 473 RD1/4PS473J
 0.5 Ω \rightarrow 0R5 RN2H0R5K
 1 Ω \rightarrow 010 RS1P010K
- Ex.2 When there are 3 effective digits (such as in high precision metal film resistors).
- 5.62k Ω \rightarrow 562 \times 10¹ \rightarrow 5621 RN1/4PC5621F

LIST OF ASSEMBLIES

Mark	No.	Description	Part No.
NSP		MACB ASSY	VWM1535
NSP		PKSB ASSY	VWG1555
NSP		FG ASSY	VWG1556
NSP		TNSB ASSY	VWG1557
NSP		BISB ASSY	VWG1558
NSP		LMSB ASSY	VWG1612
NSP		FRPB ASSY (CLD-V860/KU, KC)	VWM1605
NSP		FRPB ASSY (CLD-2750K/RD, RDXIN)	VWM1606
NSP		DIKB ASSY	VWG1635
NSP		VRSB ASSY	VWG1643
NSP		FLKB ASSY (CLD-V860/KU, KC)	VWG1665
NSP		FLKB ASSY (CLD-2750K/RD, RDXIN)	VWG1671
NSP		KALB ASSY (CLD-V860/KU, KC)	VWG1667
NSP		KALB ASSY (CLD-2750K/RD, RDXIN)	VWG1676
NSP		JACB ASSY	VWV1422
		MOTHER ASSY (CLD-V860/KU, KC)	VWS1216
		MOTHER ASSY (CLD-2750K/RD, RDXIN)	VWS1203
		KRAB ASSY	VWG1640
		GYCB ASSY (CLD-V860/KU, KC ONLY)	VWV1434
Δ		SYPS ASSY (CLD-V860/KU, KC)	VWR1260
Δ		SYPS ASSY (CLD-2750K/RD, RDXIN)	VWR1247

MACB ASSY

OTHERS	PC Board MACB	VNP1479
--------	---------------	---------

PKSB ASSY

SWITCHES	S104, S105	DSG1017
----------	------------	---------

FG ASSY

SEMICONDUCTOR	D101	GP1S24
---------------	------	--------

TNSB ASSY

SWITCH	S111	DSG1017
--------	------	---------

BISB ASSY

SWITCH	S112	DSG1017
--------	------	---------

LMSB ASSY

SWITCHES	S101-S103	DSG1017
----------	-----------	---------

OTHERS	CN101 12P FFC CONNECTOR	52044-1245
--------	-------------------------	------------

FRPB ASSY

● CONTRAST OF VWM1605 AND VWM1606
 VWM1605 and VWM1606 have the same construction except for the following :

Mark	Symbol & Description	Part No.		Remarks
		VWM1605	VWM1606	
	FLKB ASSY	VWG1665	VWG1671	
	KALB ASSY	VWG1667	VWG1676	

● PARTS LIST FOR VWM1605

OTHERS	PC Board FRPB	VNP1512
--------	---------------	---------

DIKB ASSY

SWITCHES	S301-S317	VSG1008
----------	-----------	---------

RESISTORS	All Resistors	RD1/6PM□□□J
-----------	---------------	-------------

OTHERS	CN301 BOARD TO BOARD CONNECTOR 6P	9133S-06A
--------	-----------------------------------	-----------

VRSB ASSY

SWITCH	S601	VSH1011
--------	------	---------

CAPACITORS	C602 C601, C603, C604	CKPUYB102K50 CKPUYY103N16
------------	--------------------------	------------------------------

RESISTORS	VR601, VR602 (10k Ω) Other Resistors	VCS1040 RD1/6PM□□□J
-----------	---	------------------------

Mark No.	Description	Part No.
OTHERS		
CN601	FJ CONNECTOR 6P PCB HOLDER	06P-FJ VNE2026

FLKB ASSY

● CONTRAST OF VWG1665 AND VWG1671
 VWG1665 and VWG1671 have the same construction except for the following :

Mark	Symbol & Description	Part No.		Remarks
		VWG1665	VWG1671	
	R120 R121 R130	RD1/8PM102J RD1/8PM381J RD1/8PM2R2J	Not used Not used RD1/8PM110J	

● PARTS LIST FOR VWG1665

SEMICONDUCTORS	IC101 IC102 Q102 Q101, Q103, Q104 D101	PD3319A S-806D DTA144ES DTC114ES 1SS252
----------------	--	---

	D102, D103	SLR-342MCT31
--	------------	--------------

SWITCHES	S101-S107	VSG1008
----------	-----------	---------

CAPACITORS	C109 C103, C105 C111-C113 C107, C110 C108	CEAL100M16 CEAL470M6R3 CKPUYB101K50 CKPUYB102K50 CKPUYF223Z25
------------	---	---

RESISTORS	C102, C104	CKPUYY103N16
-----------	------------	--------------

RESISTORS	R110, R113, R114 R127 Other Resistors	RN1/6PQ1001F RN1/6PQ5101F RD1/6PM□□□J
-----------	---	---

OTHERS	CN101 2.5mm PITCH PIN HEADER CN102 FFC BOTTOM CONNECTOR 21P CN103 2mm PITCH BOTTOM CONNECTOR X101 CERAMIC RESONATOR (8MHz) CN104 2mm PITCH CONNECTOR PLUG	1068-06C-PP 52492-2120 BTMK19S-1S EFOEC8004A4 TKC-A08P-D1
--------	---	---

	V101 FL TUBE SPACER FL HOLDER	VAV1039 VEC1599 VNF1091
--	-------------------------------------	-------------------------------

KALB ASSY

● CONTRAST OF VWG1667 AND VWG1676
 VWG1667 and VWG1676 have the same construction except for the following :

Mark	Symbol & Description	Part No.		Remarks
		VWG1667	VWG1676	
	D207 S207 R207	SLR-342MCT31 VSG1008 RD1/6PM181J	Not used Not used Not used	

● PARTS LIST FOR VWG1667

SEMICONDUCTORS	IC201 D206, D207 D201, D210 D202-D205, D208, D209	BU2040 SLR-342MCT31 SLR-342VCT31 SLR-342YCT31
----------------	--	--

SWITCHES	S201-S209	VSG1008
----------	-----------	---------

CAPACITORS	C202, C204	CKPUYY103N16
------------	------------	--------------

RESISTORS	All Resistors	RD1/6PM□□□J
-----------	---------------	-------------

OTHERS	REMOTE SENSOR UNIT CN201 2mm PITCH B TO B CONNECTOR	GP1U26X TKC-A08X-B1
--------	--	------------------------

JACB ASSY

SEMICONDUCTORS	IC502 IC501	NJM2068D NJM4558DX
----------------	----------------	-----------------------

CAPACITORS	C514, C515 C521 C504, C505 C509, C512 C510, C513	CEJA101M10 CKCYF473Z50 CKPUYB271K50 CKPUYX122M16 CKPUYX152M16
------------	--	---

	C501, C502, C507, C508 C503, C506	CKPUYY103N16 CQMA104J50
--	--------------------------------------	----------------------------

RESISTORS	VR501, VR502 (10k Ω) Other Resistors	VCS1040 RD1/6PM□□□J
-----------	---	------------------------

OTHERS	CN502 FJ CONNECTOR 6P CN503 18P FFC CONNECTOR CN501 2mm PITCH BOTTOM CONNECTOR	06R-FJ 52044-1845 BTMK19P-1R PLUG RKN1006
--------	--	---

	JA502 HEADPHONE JACK JA501, JA503 MICROPHONE JACK	VKN1147 VNE1102 VNE2023
--	--	-------------------------------

MOTHER ASSY

● CONTRAST OF VWS1216 AND VWS1203
 VWS1216 and VWS1203 have the same construction except for the following :

Mark	Symbol & Description	Part No.		Remarks
		VWS1216	VWS1203	
	IC803 Q501 Q811, Q812, Q813 Q815, Q816	Not used Not used Not used Not used	PD0198A 2PB709A 2PD601A 2SC1740S	
	F575 L200, L201 L590 L591	VTH1005 VTH1020 VTH1020 Not used	Not used Not used LAU270J LAU270J	

Mark	No.	Description	Part No.	Remarks
Mark	Symbol & Description	Part No.		Remarks
		VWS1216	VWS1203	
	C105, C612, C614	Not used	CKSQYF103Z50	
	C641	Not used	CKSQYF103Z50	
	C588	CEAS470M10	CEAS471M10	
	C594	Not used	CCSQCH150J50	
	C596	Not used	CCSQCH470J50	
	C598	Not used	CCSQCH390J50	
	C611, C642	Not used	CEAS470M10	
	C613	Not used	CEAL470M16	
	C616	Not used	CKSQYF473Z25	
	C617	Not used	CCSQCH070D50	
	C618	Not used	CCSQCH220J50	
	C620	Not used	CCSQCH100D50	
	R110	Not used	RS1/10S000J	
	R561	RS1/10S821J	Not used	
	R562 - R569	RS1/10S881J	Not used	
	R581	RD1/6PM103J	Not used	
	R582	RS1/10S103J	Not used	
	R598, R623	Not used	RS1/10S101J	
	R599	Not used	RS1/10S152J	
	R600	RS1/10S000J	RS1/10S821J	
	R601	Not used	RS1/10S562J	
	R602	Not used	RS1/10S473J	
	R612	Not used	RS1/10S182J	
	R615, R617, R622	Not used	RS1/10S472J	
	R616	Not used	RS1/10S332J	
	R618	Not used	RS1/10S122J	
	R619, R625	RN1/10SC750D	RS1/10S750J	
	R620	Not used	RS1/10S102J	
	R621	Not used	RS1/10S271J	
	R624	Not used	RS1/10S331J	
	R626	RS1/10S000J	Not used	
	R635	Not used	RS1/10S332J	
	CN110	BTFN20S - 3SB7	Not used	
	B to B connector 20P			
	CN113	BTFN6S - 3SB7	Not used	
	B to B connector 6P			

• PARTS LIST FOR VWS1216

SEMICONDUCTORS

IC904	BA10393F
IC202, IC205, IC903, IC905	BA4560F
IC351	CA0002AM
IC803	LA6510
IC802	LC78681KE
IC206	NJM78L08A
IC207	NJM79L08A
IC801	PAC002A
IC901	PAC003A
IC400	PAC005B
IC500	PD0192A
IC101	PD0212B
IC201	PD2026B(L)
IC902	TA8410AK
IC804	TC4W53F
IC501	TCT504F
Q102, Q916	2PB709A
Q201, Q202, Q451, Q475, Q805	2PD601A
Q840, Q903, Q904, Q907, Q908	2PD601A
Q915, Q917	2PD601A

Mark	No.	Description	Part No.
	Q834		2SA854S
	Q411, Q803		2SC2412K
	Q152		2SC3802K
	Q204, Q205, Q231		2SD2144S
	Q208, Q209, Q918		UN2112
	Q103, Q207, Q901, Q910		UN2212
	D202		11EQS06
	D102, D180, D203, D204, D801		1SS254
	D901, D902, D905, D963		1SS254
	D802		1SS355
	D201		KV1851
	D110		MTZJ5. 1B

COILS AND FILTERS

L413	LAU100J
L410	LAU101J
L351, L802-L804	LAU181J
L202, L204, L205, L352, L412	LAU220J
L461, L470, L800, L801	LAU220J
L411, L571	LAU270J
L420, L421, L580	LAU430J
L462	LAU560J
L414	LAU8R2J
L460	LFA561J
F501	VTF1055
F575	VTH1005
L200, L201, L590	VTH1020

SWITCH

S12	VSH1009
-----	---------

CAPACITORS

C562	CCSQCH050C50
C436, C809, C811	CCSQCH070D50
C159, C420, C421, C438, C466	CCSQCH100D50
C583	CCSQCH100D50
C258, C259, C370, C810, C846	CCSQCH101J50
C848, C944	CCSQCH101J50
C437, C474	CCSQCH120J50
C416	CCSQCH121J50
C415, C418, C434, C475	CCSQCH150J50
C161, C353, C812	CCSQCH151J50
C352, C552	CCSQCH180J50
C220, C232, C579, C813, C950	CCSQCH220J50
C162, C417, C591, C935	CCSQCH221J50
C371, C419, C433, C467, C931	CCSQCH270J50
C106, C107, C354, C435, C452	CCSQCH330J50
C553, C563, C580	CCSQCH330J50
C351, C425, C476	CCSQCH390J50
C260-C263, C464, C468	CCSQCH470J50
C787	CCSQCH471J50
C375, C561, C806	CCSQCH680J50
C374, C814	CCSQCH820J50
C460, C462	CCSQCH910J50
C439	CEAL100M16
C836, C844	CEAL470M16
C450, C838	CEALNP470M6R3
C972	CEANP220M10
C227, C281, C904	CEAS10M50
C228, C274, C275, C367	CEAS100M50
C364, C424, C917	CEAS101M10
C922, C967	CEAS220M25

**CLD - V860,
CLD - 2750K**

Mark	No.	Description	Part No.
	C821		CEAS220M50
	C845, C902, C926		CEAS2R2M50
	C101, C207, C225, C226		CEAS470M10
	C252, C253, C256, C270, C271		CEAS470M10
	C279, C363, C369, C412, C484		CEAS470M10
	C491, C493, C530, C534, C538		CEAS470M10
	C550, C572, C585, C588, C801		CEAS470M10
	C803, C833, C842, C893, C927		CEAS470M10
	C933, C974, C975		CEAS470M10
	C255, C257		CEAS471M10
	C850, C870		CEAS4R7M50
	C368, C913, C943		CEASR47M50
	C968, C987		CEHAQ220M50
	C490, C891, C907, C914, C936		CKSQYB102K50
	C919		CKSQYB332K50
	C361, C362		CKSQYB392K50
	C355-C358, C377, C909		CKSQYB472K50
	C104, C110, C160, C196-C198		CKSQYF103Z50
	C213-C215, C231, C234, C251		CKSQYF103Z50
	C254, C286, C288, C372, C373		CKSQYF103Z50
	C376, C413, C451, C454, C485		CKSQYF103Z50
	C531-C533, C539, C570, C571		CKSQYF103Z50
	C577, C578, C581, C589, C788		CKSQYF103Z50
	C802, C804, C807, C831, C832		CKSQYF103Z50
	C834, C835, C843, C872, C876		CKSQYF103Z50
	C888, C892, C894, C918		CKSQYF103Z50
	C928, C929, C932, C937, C938		CKSQYF103Z50
	C941, C961, C962, C964, C971		CKSQYF103Z50
	C982		CKSQYF103Z50
	C102, C103, C122, C151		CKSQYF104Z25
	C284, C285, C305, C365, C366		CKSQYF104Z25
	C422, C423, C453, C457, C458		CKSQYF104Z25
	C492, C494, C551, C574, C582		CKSQYF104Z25
	C587, C592, C840, C841, C847		CKSQYF104Z25
	C873, C874, C901, C910-C912		CKSQYF104Z25
	C915, C976, C981, C983		CKSQYF104Z25
	C837, C921, C930		CKSQYF223Z50
	C359, C360, C905, C951		CKSQYF224Z25
	C280		CKSQYF333Z25
	C465, C808, C815, C875, C877		CKSQYF473Z25
	C924, C925		CKSQYF473Z25
	C942		CQMA103J50
	C920		CQMA104J50
	C278, C282		CQMA152J50
	C479, C908		CQMA154J50
	C903		CQMA222J50
	C973		CQMA224J50
	C934		CQMA681J50
	C483, C923		CQMA683J50
	C871 (10 μF/16V)		VCH1152
	VC901 (20pF)		VCM-008
RESISTORS			
	R521		RD1/6PM010J
	R581		RD1/6PM103J
	R259, R260		RD1/6PM183J
	R420		RD1/6PM470J
	R261, R262		RD1/6PM473J
	R619, R625		RN1/10SC750D
	R490, R987, R989		RN1/10SE103D
	R880, R883		RN1/10SE104D
	R879, R986, R990		RN1/10SE333D
	R881, R882		RN1/10SE473D

Mark	No.	Description	Part No.
	VR450	(2.2kΩ, 0.1W)	PCP1025
	VR603	(4.7kΩ, 0.1W)	PCP1028
	VR604, VR607, VR608, VR612	(47kΩ, 0.1W)	PCP1031
	Other Resistors		RS1/10S□□□J

OTHERS

CN108	12P FFC CONNECTOR	52045-1245
CN102, CN104	21P FFC CONNECTOR	52045-2145
CN103	23P FFC CONNECTOR	52233-2310
CN106	11P TOP POST	B11P-SHF-1AA
CN110, CN203	B TO B CONNECTOR 20P	BTFN20S-3SB7
CN113	B TO B CONNECTOR 6P	BTFN6S-3SB7
JA3, JA4	REMOTE CONTROL JACK	RKN1004
	PCB BINDER	VEF1040
JA15	1P PIN JACK	VKB1063
JA6	4P PIN JACK	VKB1065
JA13	RF PIN JACK	VKB1068
	SCREW TERMINAL	VNE1948
KN101, KN102	EARTH METAL	VNF1084
X101	CERAMIC RESONATOR(9.00MHz)	VSS1040
X201	CRYSTAL RESONATOR(16MHz)	VSS1057
X550	CRYSTAL RESONATOR(14.318MHz)	VSS1073

KRAB ASSY

SEMICONDUCTORS

IC101, IC102, IC105, IC106	BA4560F
IC108, IC109, IC113	BA4560F
IC103	BU4053BCF
IC107	LH5P832N-12
IC104	PM0007A
Q104	2SD2114K
Q105	2SK184
Q107	DTA124EK
Q101-Q103, Q106	DTC124EK
D103-D106, D108, D109	DA204K
D107	DTZ4.7B

COILS

L102, L104, L105	LFA100J
L103	LFA3R9J

CAPACITORS

C152-C154, C163	CCSQCH101J50
C133	CCSQCH181J50
C120, C135-C139	CCSQCH390J50
C111, C115	CCSQCH680J50
C165, C166	CCSQSL331J50
C101, C102, C105, C106	CEANP010M50
C121, C122, C125, C127	CEAS100M50
C141, C147-C149, C168, C169	CEAS101M10
C126	CEAS330M16
C134, C162	CEJA2R2M50
C112, C118	CEJA470M6R3
C119	CFTYA104J50
C110, C114, C132	CFTYA223J50
C158	CFTYA823J50
C109, C113	CKSQYB332K50
C131, C159	CKSQYB472K50
C103, C104, C108, C116, C117	CKSQYF103Z50
C123, C124, C129, C130, C142	CKSQYF103Z50
C150, C151, C155, C156	CKSQYF103Z50
C160, C161, C167, C178, C179	CKSQYF103Z50

Mark	No.	Description	Part No.
	C140, C143-C146, C164 C157		CKSQYF104Z25 CKSQYF333Z50

RESISTORS

All Resistors RS1/10S□□□J

OTHERS

CN102	18P FFC CONNECTOR	52045-1845
CN101	B TO B CONNECTOR 20P PCB BINDER	BTFN20P-3RD7 VEF1040
JA101	2P PIN JACK SCREW TERMINAL	VKB1031 VNE1948

GYCB ASSY

SEMICONDUCTORS

IC104	LC32464P-80
IC106	MC14577CP
IC105	PD0198A
IC103	PDC016A
Q170, Q171	2PD601A

COILS

L105, L106 L107	LFA220J LFA4R7J
--------------------	--------------------

CAPACITORS

C180	CCSQCH060D50
C201-C204	CCSQCH150J50
C181, C182	CCSQCH220J50
C184	CCSQCH330J50
C183	CCSQCH680J50
C186, C188	CEAL470M6R3
C136, C138, C170, C172, C175	CEAS470M10
C177, C178, C190	CEAS470M10
C135, C137, C150, C171	CKSQYF103Z50
C173, C174, C176, C179, C185	CKSQYF103Z50
C187, C189, C191, C205, C206 C192	CKSQYF103Z50 CKSQYF104Z25

RESISTORS

R118	RS1/10S112F
R119	RS1/10S123F
R190	RS1/10S132F
R121	RS1/10S222F
R123	RS1/10S301F
R172	RS1/10S681F
Other Resistors	RS1/10S□□□J

OTHERS

CN101	B TO B CONNECTOR 20P	BTFN20P-3RD7
CN102	B TO B CONNECTOR 6P SCREW TERMINAL	BTFN6P-3RD7 VNE1948

Mark	No.	Description	Part No.
------	-----	-------------	----------

SYPS ASSY

• **CONTRAST OF VWR1260 AND VWR1247**

VWR1260 and VWR1247 have the same construction except for the following :

Mark	Symbol & Description	Part No.		Remarks
		VWR1260	VWR1247	
△	IC5	Not used	MK1210	
△	Q1	2SK2045	2SK1480	
	Q20, Q22	2SA1598	T7F4T	
	Q21, Q23	2SC4148	T7F4S	
△	D3	Not used	RD18FB2	
△	D4	Not used	PS2501L1-1M	
△	D5	MTZJ2.7B	MTZJ3.8A	
△	D6	K1V24	Not used	
△	D8	Not used	EG01C	
△	PUT1	Not used	N13T1	
△	F1 (125V 2A)	REK1078	Not used	
△	F1 (250V 2A)	Not used	AEK1057	

• **PARTS LIST FOR VWR1260**

SEMICONDUCTORS

IC20	HA17431P
△ IC2	ICP-N15
△ IC1	ICP-N20
IC21	NJM4558D
Q20, Q22	2SA1598
Q27, Q30, Q32	2SA933S
Q24	2SB891F
Q25, Q29, Q31	2SC1740S
△ Q2, Q3	2SC3377
Q21, Q23	2SC4148
Q26	2SD2007
△ Q1	2SK2045
D25-D27, D30, D31	AG01Z-V0
△ D1	D2SB60
△ D2	EG01C
△ D6	K1V24
△ D5	MTZJ2.7B
D29	MTZJ8.2B
△ D20	PS2501L1-1M
D40	RD33FB2
D23, D24	RK36
D21, D22	RL4Z
△ D7	1SS270A

RESISTORS

△ R22-R25	(47Ω, 1/6W)	VCN1033
△ R27	(0.47Ω, 1/2W)	VCN1046
△ R29	(68Ω, 1/4W)	VCN1048
△ R31	(8.2Ω, 1/4W)	VCN1050

OTHERS

△ F1	FUSE (125V 2A)	REK1078
△ F2	FUSE	VEK1033
△ F3, F4	FUSE	VEK1034
△ F5, F6	FUSE (125V 1.0A)	VEK1036

5. SELF-DIAGNOSTIC FUNCTIONS

5.1 SELF-DIAGNOSTIC FUNCTIONS

The self-diagnostic functions automatically display an error code on the TV screen and front panel fluorescent display section when there is an error. The customer checks the error code and conveys it to the service personnel to make repairs more efficient.

After an error occurs, even if the error code goes off, you can display the error code again by holding down the **CLEAR** key for 10 seconds (except a loading error **L *** display). At that time, partial error is displayed with the mechanism switch information. However, if the power cord is unplugged, the error code information is lost.

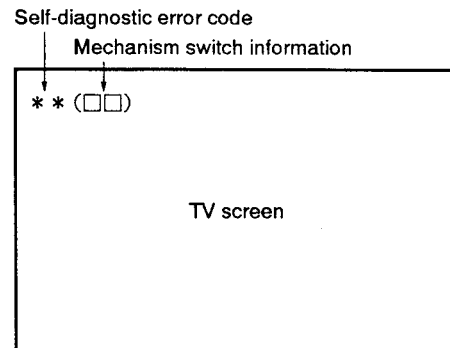

Fig. 1 TV screen display

This table explains the information for analyzing the cause when an error occurs with the CLD player.

Self-diagnostic error code	Contents	Conditions	Probable cause
H0	Spindle overcurrent detection error.	In the play state, overcurrent was detected in the spindle motor. Monitoring starts 5 seconds after the start of play or special playback mode, this error is detected if the overcurrent port is "L" for 4 seconds.	<ul style="list-style-type: none"> • Motor NG • Clamper rubbing
U0	FG abnormality error	<ol style="list-style-type: none"> ① At LD start-up, the rate of rotation calculated from the FG was less than 15 rpm for 5 consecutive seconds from the spindle run command. ② At CD start-up, there was less than 1/8th rotation even after 5 seconds had passed since the end of acceleration. ③ During play search, CD : subcodes are being read/LD : Phillips codes are being read and the spindle is locked, but a state in which the rate of rotation calculated from the FG was less than 15 rpm continued for 5 seconds or more. In the above case, it is judged that an abnormality has occurred in the FG sensor and that accurate rotation rate calculation has become impossible. 	<ul style="list-style-type: none"> • FG sensor abnormality, FG signal not coming to mechanism controller • FG sensor clogged • Rubbing between FG sensor and slit • Turntable dropped • FG slit deposition NG
H1	Partial short error	<ol style="list-style-type: none"> ① At LD start-up, the speed did not reach 1200 rpm within a certain time (12 seconds) after the spindle run command. ② At CD start-up, a certain speed (313 rpm) was not reached within 6 seconds from the end of spindle acceleration. 	<ul style="list-style-type: none"> • Spindle motor NG • Commutator NG • Bearing too tight • Power supply NG
H2 A0	Power supply abnormality error	<p>– 5V power supply abnormality detected.</p> <p>The power supply abnormality port is constantly monitored and if its signal stays high for about 1 second consecutively, the power supply is judged to be abnormal.</p>	<ul style="list-style-type: none"> • – 5V not fed from SYPS assy • Parts shorted
L *	Loading error	<ol style="list-style-type: none"> ① When loading operation goes over time (approx. 10 sec.). ② When assist at disc sense entry ends and is not tilt neutral. ③ When assist at set up entry ends and is not tilt neutral. 	<ul style="list-style-type: none"> • Tilt switch 1, 2, 3 abnormal, so tilt/loading state not read in correctly • Tilt/loading mechanism mechanically locked • Drive IC NG • Power supply NG
E *	Slider error	During slider movement, a time over-run occurred (track count search 20 seconds, mandatory movement 10 seconds)	<ul style="list-style-type: none"> • Slider ceased being able to run • The slider mechanism is mechanically locked and can no longer move to its target. • Slider position switch NG • Flexible cable pulled out • Drive IC NG • Power supply abnormal
U1	Miss clamp error	<ol style="list-style-type: none"> ① During LD setup, after 1/8th rotation, the track count during 1/8 rotation exceeded 511. ② During start-up, the focus was lost once and refocusing was attempted, but the focus could not be locked. ③ Two FG pulses did not come within 800 ms from from the start of LD start-up. ④ The disc clamp operation did not end within 5 seconds. 	<ul style="list-style-type: none"> • Disc sandwiched • Disc shifted • Spindle motor NG • Disc scratched or dirty defocused during start-up • Two discs loaded • PU actuator NG • Tilt sensor NG • Tilt neutral NG (tilt base NG)

Self-diagnostic error code	Contents	Conditions	Probable cause
P *	Spindle error	① During TOC reading with an LD, the spindle servo was not locked within 60 seconds from the start of the spindle run. ② When CAV/CLV determination is not finished within 60 seconds from spindle servo lock. ③ The codes could not be read for 10 - 15 seconds consecutively for an LD or 7 - 10 seconds for a CD/CDV and the spindle servo was not locked. ④ The speed exceeded 2100 rpm during LD start up.	P0: •PH code, SUB-Q code can not be read •VCO, PLL offset out of adjustment •Disc defect P5: •PAL disc, mirror disc, etc. PLAY •No RF P6: •Spindle servo does not lock •Spindle motor NG
F *	Focus error	① "In the "no disc" state, a setup command was received from the mode controller. ② When LD is out of focus when slider is moved to starting position during set up. In case of CD/CDV is NG even after three focus tries. ③ During start-up, the maximum slider servo duty continued for 3 loops or more.	F5: •CD, LD on top of each other •LD scratched or dirty defocused during slider movement •Disc NG •Slider position switch NG F6: •Inner edge of disc scratched or dirty •Slider ran into inner edge mechanical stopper

* Besides the above errors, there is the "U2" communications error (the mode controller could not communicate normally with the mechanism controller)
 The probable cause is a defective mechanism controller, disconnected cable, etc..

* Mechanism mode contents (meanig of * for L * etc.)

- | | | |
|----------------|----------------------------|---------------------|
| 0 : Play | 5 : Setup (rotation start) | 9 : Side A → Side B |
| 1 : Open | 6 : TOC read | A : Side B → Side A |
| 2 : Standby | 7 : Play | |
| 3 : Clamp | 8 : Search | |
| 4 : Disc sense | | |

5.2 FORMAT OF THE MECHANISM SWITCH INFORMATION WHICH IS TRANSMITTED TO THE MODE CONTROL IN THE ERROR OCCURRENCE

• Mechanism switch information (1 7)

Mechanism control → Mode control
 Communication byte address 5 (COMBUF5)
 (Mode control displays this value as it is.)

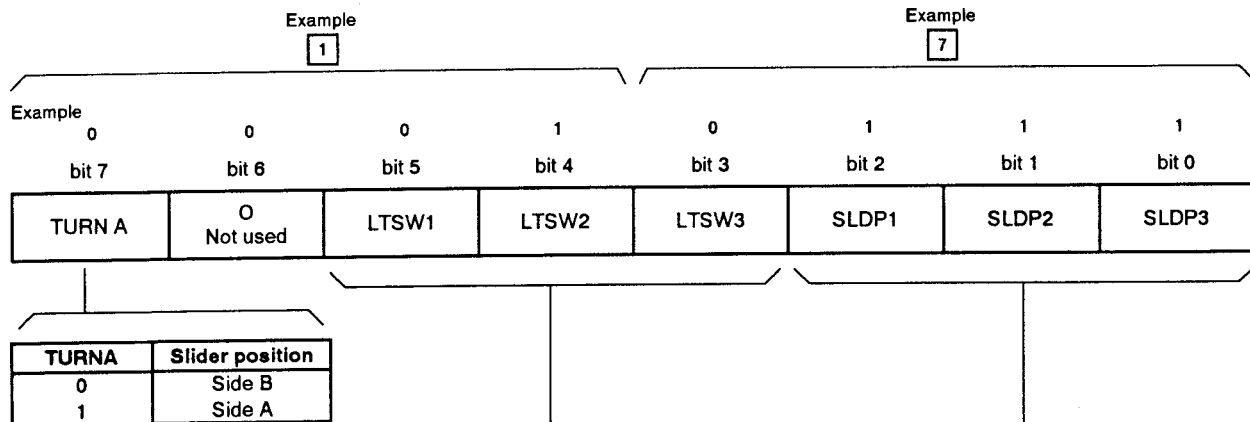

Example of 1 7 is indicated as follows.

(Slider : Side B
 Tilt : Tilt +
 Position : B-INSIDE

LTSW			Loading/tilt position
1	2	3	
0	1	1	Open (Tray open state)
0	0	1	Loading (During move the tray horizontally)
1	0	1	Standby (Tray close & spindle down state)
1	0	0	Clamp (Durring spindle up or down)
0	0	0	Tilt - (Clamp state)
0	1	0	Tilt + (Clamp state)
1	1	0	Tilt limit (Clamp state)

SLDP			Slider position
1	2	3	
1	0	0	CD active position
1	0	1	CDV active position
1	1	0	LD active position
0	1	1	CD inside position
1	1	1	Side B inside position

6. ADJUSTMENTS

6.1 TEST MODE

1) How to start the test mode

On the MOTHER ASSY, Short circuit the test mode JP W490 and W491, the test mode is started by pressing the power switch ON. (Fig. 1)

After confirming that all FL indicators are lit, remove test mode jumper wire and GND connection. If you have test mode remote control unit (GGF1067), press ESC key and TEST key in order with power switch ON.

2) How to cancel the test mode

Turn power switch OFF. Or, press test mode remote control ESC key.

3) Functions and key control when in test mode

Note: For keys not on player or on accompanying remote control, use test mode remote control unit (GGF1067).

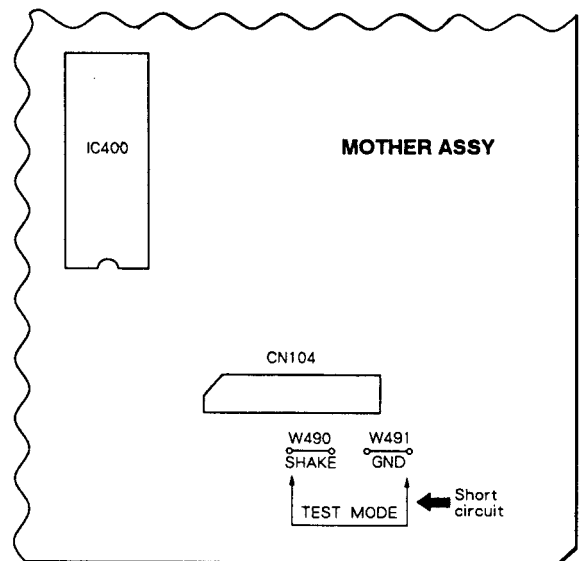

Fig. 1

Note: When you open the tray in test mode, the screen display goes out. To display the screen again, press the **DISPLAY** key.

• Key Operation in the Test Mode

Player Status	Key Operation	Function	TV Screen Display
Tray Open	⏪/⏩ SKIP (Refer to Note 1)	⏪ : Shifts the tray in the closed direction and also raises the turn table while pressing the key. ⏩ : Shifts the tray in the open direction and also lowers the turn table while pressing the key.	
Tray Open	▶ PLAY	Clamps	
Clamp	▶ PLAY	Turns the disc through TRK Servo OFF	TRK - OFF
TRK Servo OFF	▶ PLAY	TRK Servo ON	TRK - ON
TRK Servo ON	▶ PLAY	TRK Servo OFF	TRK - OFF
TILT Neutral	+ MULTI-SPEED	TILT Servo ON	T-□:ON
TILT ON	- MULTI-SPEED	TILT Neutral	T-□:N
TILT Neutral or ON	⏪/⏩ SKIP	Setting TILT Servo to OFF, can force TILT to move.	T-1 to T-E
Clamp	⏪/⏩ SCAN	Can force the slider to move	S-LD S-BIN S-CDV S-CD S-IN
Play	PAUSE	Still	
Play	■ STOP	Stop	
Stop	▲ OPEN	Open	
Play	+10 ↓ 0 to 9 ↓ ▶ PLAY	Set to SEARCH lead address input mode. Designates the SEARCH lead address through keys 0 to 9. Press the CLEAR [C] key if the designated address is incorrect. Searches the designated address upon pressing the PLAY key.	

Note 1: Press SKIP (⏪/⏩) keys after the tray is set to open state by pressing OPEN (▲) key.

Because, in tray open state, pressing PLAY (▶) key causes is to set to clamp state and SKIP (⏪/⏩) keys can not function properly.

Table 1

• **Player Operation in the Test Mode**
(Disc tray is removed)

Operate the player by selecting a test mode function with the keys on the player or on the remote control unit.

• **CD PLAYBACK**

- ① Place the CD disc on the turn table.

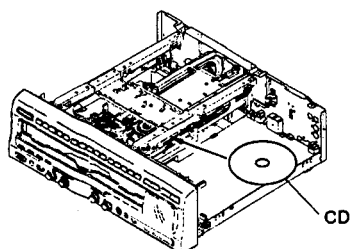

Fig. 2

- ② Press the PLAY (▶) key once.
(Twin gear starts to move.)
③ Push the cam plate (Fig. 3) in the direction of the arrow and wait until the CD disc is clamped.

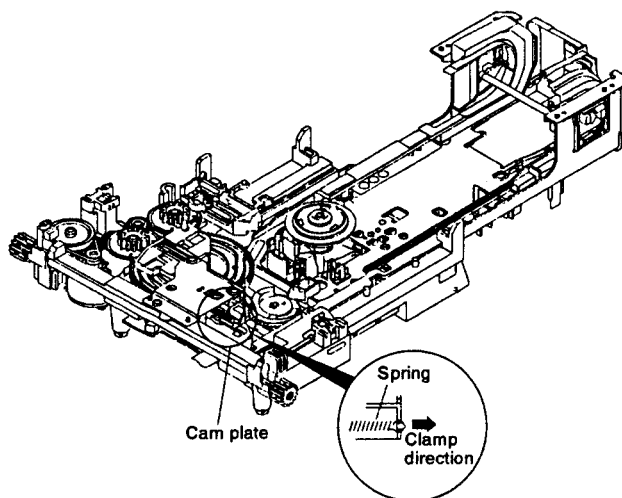
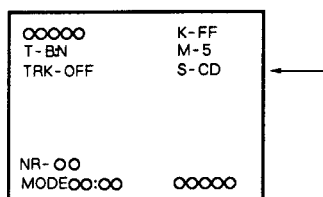

Fig. 3

- ④ Press the ◀◀ or ▶▶ keys to appear "S - CD" on the TV screen display.



TV screen display

Fig. 4

- ⑤ Press the PLAY (▶) key twice, disc will be normally playbacked.

• **LD PLAYBACK**

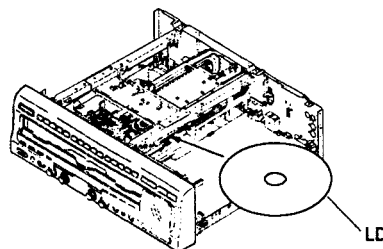
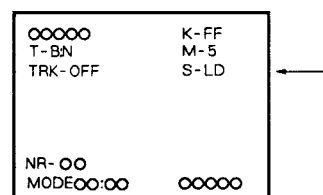

Fig. 5

- ① Press the SKIP REV (◀◀) key to raise the turn table (spindle motor section) while pressing the cam plate (Fig. 3) in the direction of the arrow. Raise it to the position where the LD disc can be easily placed on the turn table. If the turn table is raised too high, lower it with the SKIP FWD (▶▶) key.
② Place the LD disc on the turn table and press the PLAY (▶) key once to clamp the disc.
③ Press the ◀◀ or ▶▶ keys to appear "S - LD" on the TV screen display.



TV screen display

Fig. 6

- ④ Press the PLAY (▶) key twice, disc will be normally playbacked.

6.2 ADJUSTMENT PRECAUTIONS

• Equipment and jigs needed for adjustment

- CD test disc (YEDS - 7)
- LD test disc (GGV1012)
- Medium-sized blade screwdriver
- Small blade screwdriver
- Large Phillips screwdriver
- Medium-sized Phillips screwdriver
- Two-channel oscilloscope (with delay)
- Frequency counter
- TV monitor

• Preparation for Adjustment

1. Disc tray removal

1. Remove the seven screws (A) fastening the bonnet and remove the bonnet.
2. With the power supply on, press the OPEN/CLOSE (LD) button and put the disc tray in the open position.
3. While pushing the hooks (B) on both sides of the rear of the disc tray inwards, pull out the disc tray.

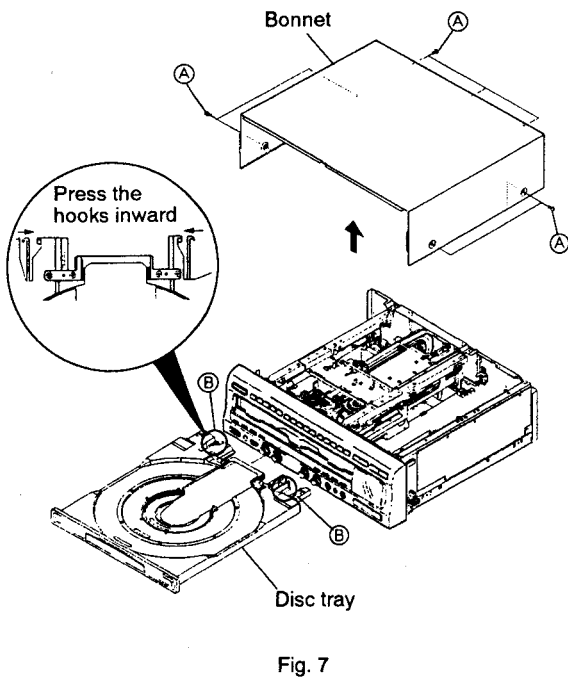

Fig. 7

Note: The adjustments other than "Electrical Adjustments 3. PLL OFFSET Adjustment" can be carried out with the disc tray mounted.

2. Diagnostic method of MOTHER assy

1. Remove the four screws (C) fastening the rear panel (L). (Fig. 8)

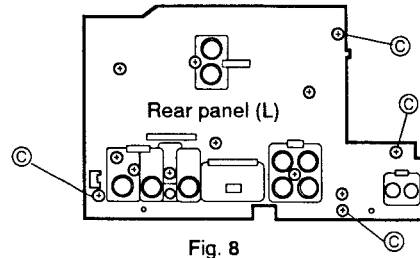

Fig. 8

2. Remove a screw (D) fastening the front side of PCB holder. (Fig. 9)
3. Remove the two screws (E) fastening the MOTHER assy. (Fig. 9)

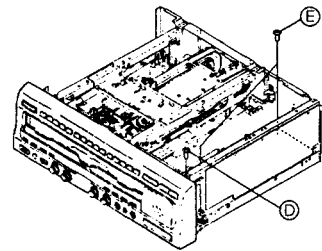

Fig. 9

4. Loosen the binder for fixing flat cable in the MOTHER assy.
5. While pulling up the rear panel (L) toward the rear, MOTHER assy will be removed with the rear panel (L). Then MOTHER assy can be diagnosed by standing it as shown in Fig. 10.

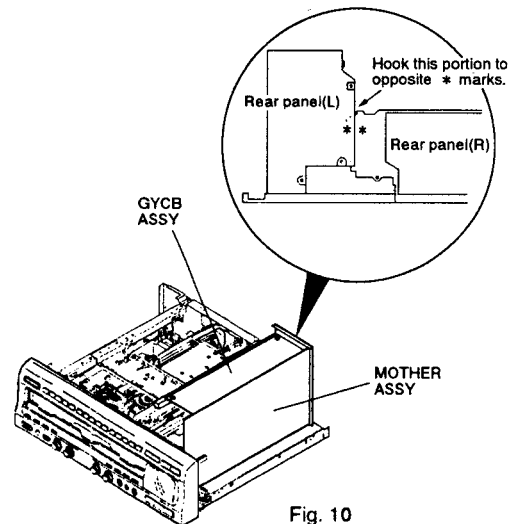

Fig. 10

Note 1: The MOTHER assy can be diagnosed with the disc tray mounted.

Note 2: When inserting the disc tray, please hold down the flat cable without hanging to the tray.

● Before adjusting mechanism system

- Centering adjustment screw and TAN adjustment screw

Note: Be careful not to turn centering adjustment screw and TAN adjustment screw past their adjustment range.

After the adjustments, apply the lock-tight to centering and TAN adjustment screws.

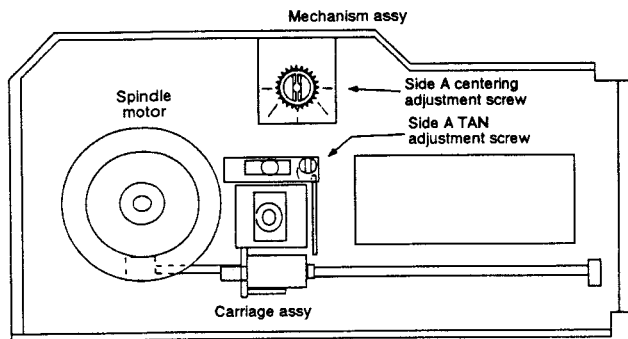

Do not turn the centering and TAN adjustment screws past their ranges, which are $\pm 0.75\text{mm}$ and $\pm 80^\circ$ from center. Apply the lock-tight after the adjustment.

Fig. 11 Mechanism assy adjustment (side A)

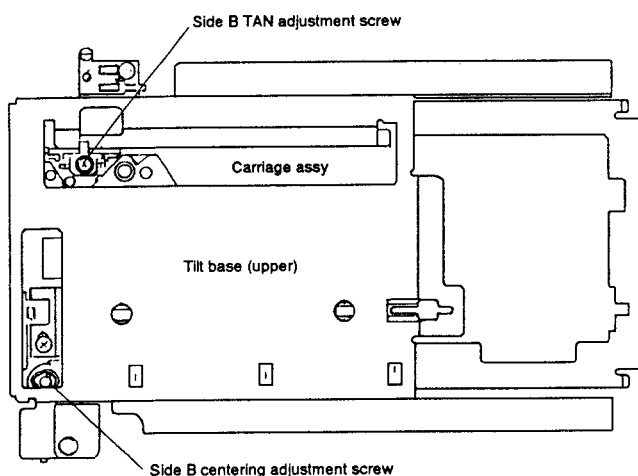

Centering adjustment range $\pm 90^\circ$
TAN adjustment range \pm two turns

Fig. 12 Mechanism assy adjustment (side B)

- The mechanical adjustments can all be carried out with disc tray mounted.

● Notes when adjusting centering

If waveform S/N is bad and difficult to observe in "3 and 8. SPDL motor centering adjustment" use the low pass filter in diagram. (Fig. 13)

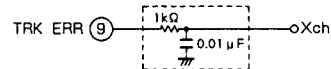

Fig. 13 Low pass filter

● Carriage assy position when adjusting centering

When moving slider to inner position to adjust the innermost track of disc during centering adjustment, be careful not to keep the mechanism stopper and carriage assy from bumping each other. (Fig. 14)

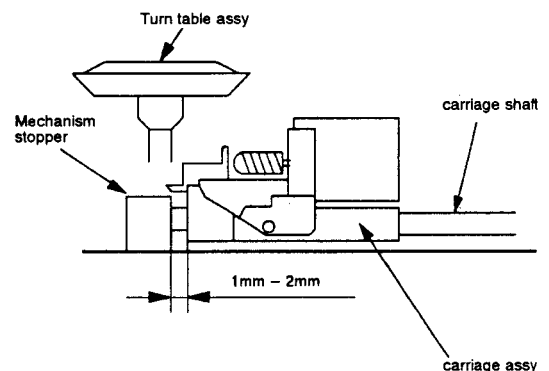

Fig. 14

● Notes when adjusting pickup assy

Please clean lens first when readjusting the pickup assy that is on this product. Also, when changing pickup assy, change whole carriage assy (VWT1100).

6.3 ADJUSTMENT LOCATION

- VR607: Side A tilt offset adjustment
- VR608: Side B tilt offset adjustment
- VR604: Focus servo loop gain adjustment
- VR603: Tracking servo loop gain adjustment
- VC901: Master clock adjustment
- VR450: Output video level adjustment
- VR612: PLL offset adjustment
(Orderin adjustment)

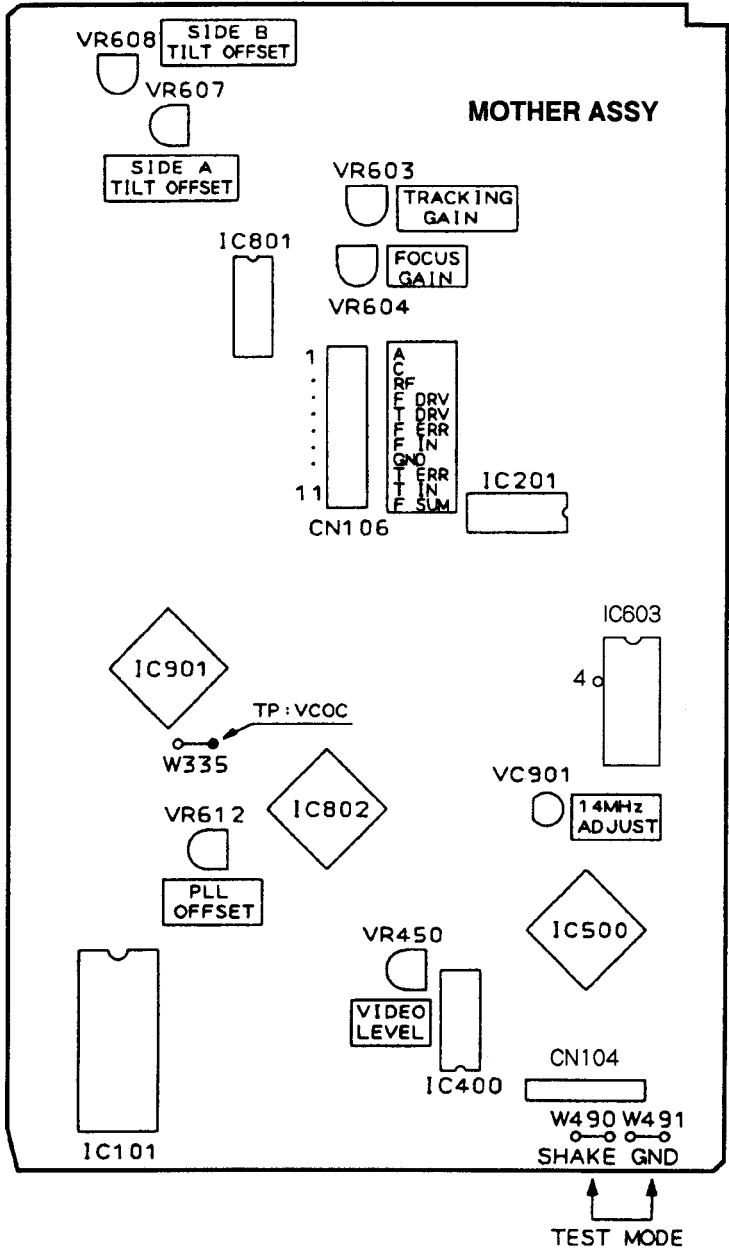
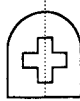
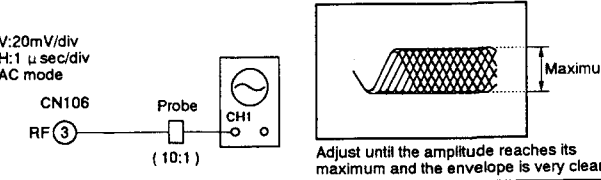
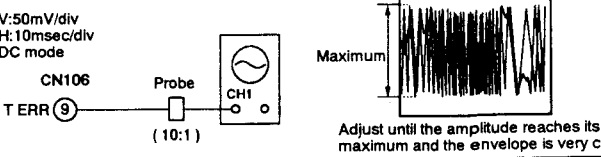
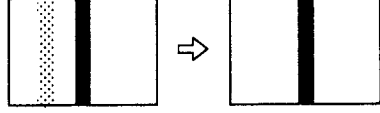
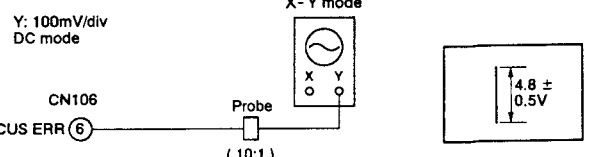
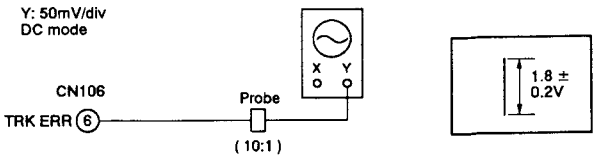
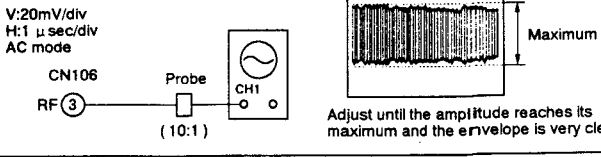
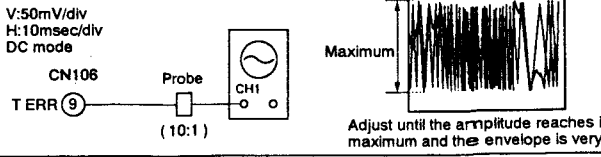
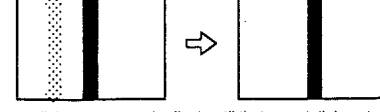

Fig. 15 Adjustment diagram of MOTHER assy

6.4 ADJUSTMENT METHOD

• Mechanical adjustment

Step	Adjustment name	Adjustment point	Measuring point and measuring mode	Player condition	Adjustment procedure	Waveform and connection diagram
1	Tilt offset adjustment	MOTHER assy VR607, VR608 (TILT OFFSET)		Test mode Disc not installed	Check the positions of VR607 and VR608 to the mechanical center with eyes. If there positions are shifted, set to the center.	Set to the mechanical center 
2	Tangential direction angle adjustment (side A)	Carriage assy TAN adjustment screw (side A)	CN106-3 (RF)	CD test disc outer track play (See position for TAN adjustment screw) TRKG-ON, TILT-ON	Adjust so that the amplitude of the RF waveform reaches its maximum and the envelope is very clear. Apply the lock-tight after the adjustment.	V:20mV/div H:1 μsec/div AC mode CN106 RF ③ Probe CH1 (10:1)  Adjust until the amplitude reaches its maximum and the envelope is very clear.
3	Spindle motor centering adjustment (side A)	Mechanism assy Centering adjustment screw (side A)	CN106-9 (TRKG error)	CD test disc inner track play (CD inside position in the program area) TRKG-OFF, TILT-ON	Adjust so that the amplitude of the tracking error waveform reaches its maximum and the envelope is very clear. Apply the lock-tight after the adjustment.	V:50mV/div H:10msec/div DC mode CN106 T ERR ⑨ Probe CH1 (10:1)  Adjust until the amplitude reaches its maximum and the envelope is very clear.
4	Crosstalk check and tilt offset re-adjustment (side A)	MOTHER assy VR607 (side A) (TILT OFFSET)	TV monitor Crosstalk monitor check	LD test disc #115 still TRKG-ON, TILT-ON	If the crosstalk is pronounced, adjust VR607 until the crosstalk is not noticeable.	 If the crosstalk is pronounced adjust until the crosstalk is not noticeable.
5	Focus servo loop gain adjustment	MOTHER assy VR604 (FOCUS GAIN)	CN106-6 (FOCUS error) CH2 "X-Y mode"	LD test disc (PLAY STANDBY) Short CN106-7 (F IN) and 8 (GND), then press the PLAY key (disc not turn)	Adjust VR604 until the waveform level is $4.8 \pm 0.5V$.	Y: 100mV/div DC mode CN106 FOCUS ERR ⑥ Probe CH1 (10:1) X-Y mode 
6	Tracking servo loop gain adjustment	MOTHER assy VR603 (TRACKING GAIN)	CN106-9 (TRKG error) CH2 "X-Y mode"	LD test disc #115 still TRKG-ON, TILT-ON	Adjust VR603 until the waveform level is $1.8 \pm 0.2V$.	Y: 50mV/div DC mode CN106 TRK ERR ⑧ Probe CH1 (10:1) X-Y mode 
7	Tangential direction angle adjustment (side B)	Carriage assy TAN adjustment screw (side B)	CN106-3 (RF)	LD test disc #115 still TRKG-ON, TILT-ON	Adjust so that the amplitude of the RF waveform reaches its maximum and the envelope is very clear. Apply the lock-tight after the adjustment.	V:20mV/div H:1 μsec/div AC mode CN106 RF ③ Probe CH1 (10:1)  Adjust until the amplitude reaches its maximum and the envelope is very clear.
8	Spindle motor centering adjustment (side B)	Mechanism assy Centering adjustment screw (side B)	CN106-9 (TRKG error)	LD test disc #115 still TRKG-OFF, TILT-ON	Loosen a black screw beside the centering adjustment screw (side B). Adjust so that the amplitude of the tracking error waveform reaches its maximum and the envelope is very clear. After adjustment is complete, tighten the black screw and apply the lock-tight.	V:50mV/div H:10msec/div DC mode CN106 T ERR ⑨ Probe CH1 (10:1)  Adjust until the amplitude reaches its maximum and the envelope is very clear.
9	Crosstalk check and tilt offset re-adjustment (side B)	MOTHER assy VR608 (side B) (TILT OFFSET)	TV monitor Crosstalk monitor check	LD test disc #115 still TRKG-ON, TILT-ON	If the crosstalk is pronounced, adjust VR607 until the crosstalk is not noticeable.	 If the crosstalk is pronounced adjust until the crosstalk is not noticeable.

(NOTE) • This adjustment can be thought to be about the same adjustment as on the manufacturing line with differing adjustment tools. Follow the adjustment procedures even for checking the adjustments.
• When you open the tray in test mode, the screen displays goes out. To display the screen again, press the **DISPLAY** key.
• The mechanical adjustment can be all carried out with disc tray mounted.

• Electrical adjustment

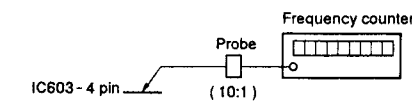
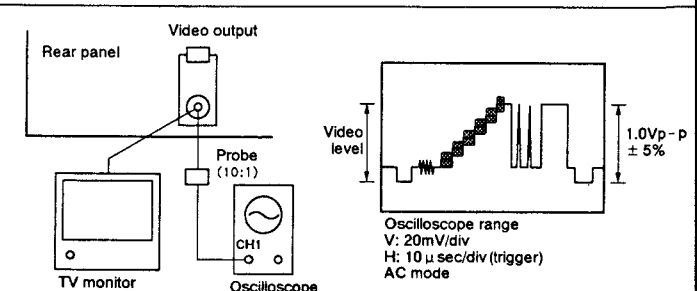
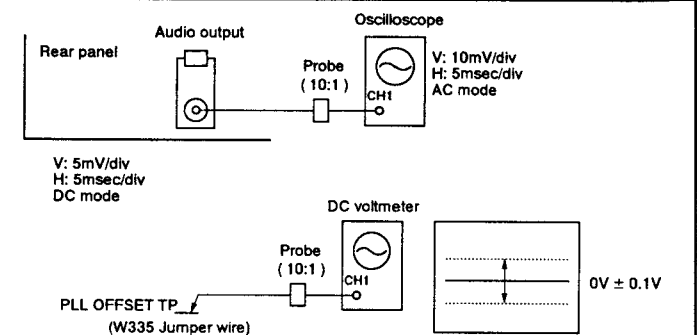
Step	Adjustment name	Adjustment point	Measurement point	Player condition	Adjustment procedure	Waveform and connection diagram
1	Master clock adjustment	MOTHER assy VC901	MOTHER assy IC603-4 (2 fsc)	Power ON	Adjust VC901 so that frequency with power on is $7.159090\text{MHz} \pm 20\text{Hz}$. Connect video output terminal and oscilloscope. (Video output terminal is terminated with 75Ω)	
2	Output video level adjustment	MOTHER assy VR450 (VIDEO LEVEL)	Video output terminal	Normal mode LD test disc #19.900 still	Adjust VR450 so that level from video signal sync tip to 100% white becomes $1\text{Vp-p} \pm 5\%$. (It's possible to terminate video output terminal with 75Ω by connecting TV monitor)	
3	PLL OFFSET adjustment	MOTHER assy VR612 (PLL OFFSET)	MOTHER assy W335 (PLL OFFSET TP)	Test mode CD test disc play TRKG servo OFF/ON	Note: Before adjusting remove disc tray. With the tracking servo off, playback digital audio and roughly adjust VR612 so that the sound is audible. Connect W335 and a DC voltmeter and while playing back digital audio, switch the tracking servo on and off and adjust VR612 so that the difference between the DC voltage when the tracking servo is on and when it is off is no greater than $0 \pm 0.1\text{V}$.	

6.5 HOW TO REPLACE THE FLEXIBLE CABLE

- ① Bend the flexible cable as shown below.

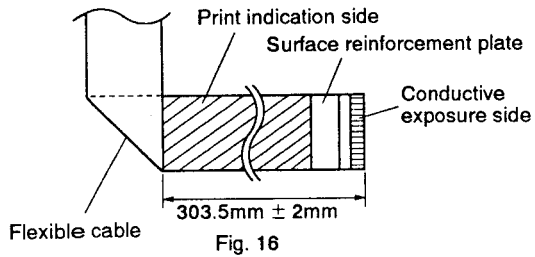

- ② Put the bended portion to hook ① of the large hill.
③ Bend the flexible cable along the wall of large hill.

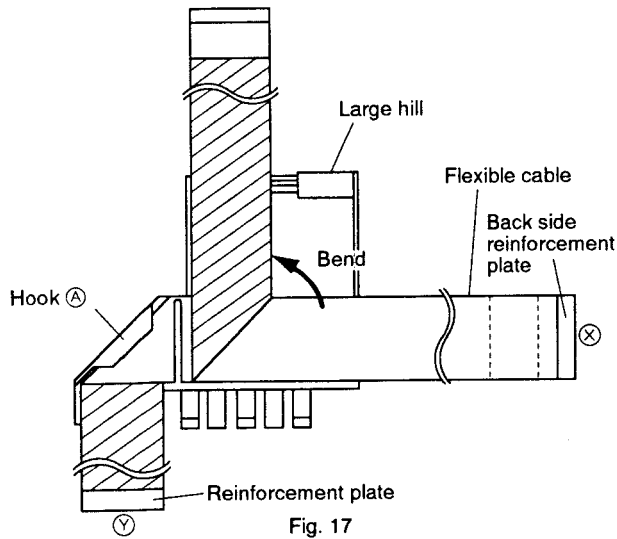

- ④ Pull the flexible cable not to slackened after passing the ① edge side of flexible cable through the large hill as shown in Fig. 18.

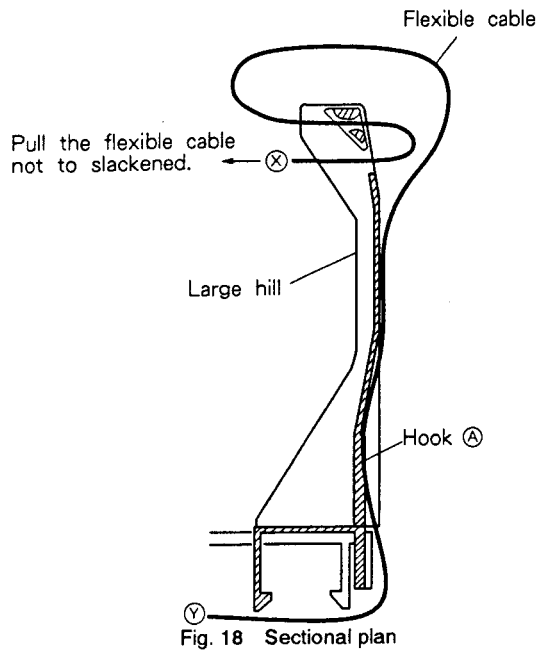

- ⑤ Put the flexible cable to hook ② after the ② edge side of flexible cable is bended along the hook ② position of the tilt base (lower), then insert to connector CN103 of the MOTHER assy.

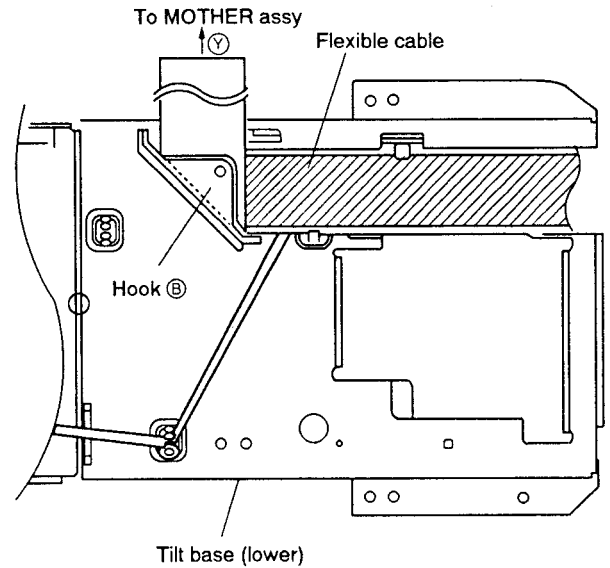

Fig. 19

- ⑥ Insert the ① edge side of flexible cable to connector of the carriage assy after passing through the FFC holder.
⑦ Move the FFC holder to touch the connector, lock the FFC holder to turn up the flexible cable to lower side.

Caution: Be sure to insert the MOTHER assy first of all for prevent the static electricity.

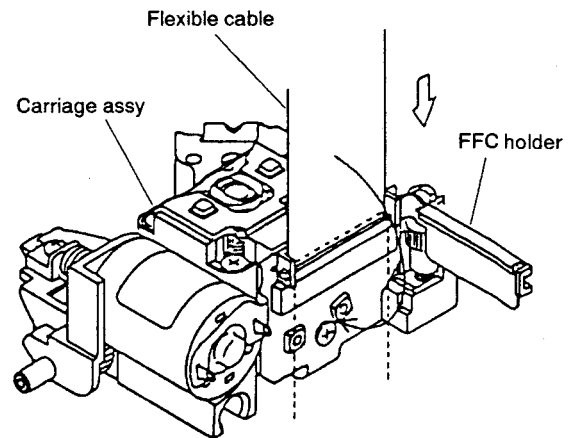

Fig. 20

7. IC INFORMATION

- The information shown in the list is basic information and may not correspond exactly to that shown in the schematic diagrams.

■ PD3319A (FLKB ASSY IC101)

• MODE CONTROL IC

• Pin Function

No.	Pin Name	I/O	Function	No.	Pin Name	I/O	Function
1	MODESEL	I	MIC control input. (AD input)	41	C	O	Display segment output.
2	ECHO VOL	I	Echo volume data value. (AD input)	42	B		
3	ONTA BAL	I	Vocal volume data value. (AD input)	43	A		
4	MODE SW	I	Mode switch. (Normal, Karaoke, External) (AD input)	44	G1	O	Display grid output.
5	AVss	I	GND	45	G2		
6	TEST	I	GND	46	G3		
7	X2	O	Not used. (N.C)	47	G4		
8	X1	I	GND	48	G5		
9	Vss	I	GND	49	G6		
10	OSC1	I	Oscillator (8MHz)	50	G7		
11	OSC2	O		51	G8		
12	XRESET(IN)	I	CPU reset (L : reset)	52	LED1	O	CD OPEN/CLOSE LED output.
13	SHAKE (ACK)	I/O	Mech. control communication requirement input. (mode control communication permission output)	53	LED2	O	LD OPEN/CLOSE LED output.
14	SEL IR	I	Remote control input.	54	P7/5	O	Not used. (N.C)
15	NC	O	Not used.	55	P7/6	O	
16	P.ON	O	Mother board power supply switching output.	56	P7/7	O	
17	EFLG	I	For measuring error rate.	57	VCC	I	Power supply. (+5V)
18	FSX	I	For measuring error rate.	58	P8/0	I	Not used. (N.C)
19	MICSENSE	I	MIC input.	59	P8/0	I	
20	P3/3	O	Not used. (N.C)	60	XDRDY (DASP7)	I	DSP(PM0007A). L : Data reception OK.
21	NO BATTLE	O	Scoring MIC switch (H : at normal. L : at competition)	61	DOG FOOD	O	Pulse output for WATCH DOG.
22	MIC1/XMIC2	O	MIC input switch. (L : MIC1, L : MIC2)	62	XREQ (DASP7)	I	DSP(PM0007A). L : Data transmission OK.
23	XINT/EXT	O	Analog audio switch. (L : player, H : External input)	63	XMIC ON	O	MIC line switch. (L : ON, H : OFF)
24	I/O DATA	O	I/O expander data output.	64	MUTE	O	Data mute output of graphics decoder.
25	I/O CLOCK	O	I/O expander clock output.	65	CDGM	I	Graphics mode input of graphics decoder.
26	THRU (DASP7)	I	H : through the digital audio L : DSP input of the digital audio	66	G - CS	O	Communication requirement output of graphics decoder (PDC018A).
27	P4/4	O	Not used. (N.C)	67	XSCK	I/O	Serial communication clock.
28	CS(DASP7)	O	DSP(PM0007A) communication requirement output.	68	S - MTOF	I	Serial communication data input.
29	P4/2	O	Not used. (N.C)	69	S - FTOM	O	Serial communication data output.
30	M	O	Display segment output.	70	XRESET (OUT)	O	Mother board reset output.
31	L			71	XCS	O	Communication requirement output of character generator (PD0188A).
32	K			72	P9/8	O	Not used. (N.C)
33	J			73	P9/7	O	Not used.
34	I			74	NC	O	Not used.
35	H			75	A/D(DASP7)	O	Transmission data switch of DSP(PM0007A). (H : address, L : data)
36	G			76	AVCC	I	+5V
37	F			77	KIN0	I	Key data input. (AD input)
38	E			78	KIN1		
39	D			79	Model switch	I	Model switch port. (AD input) (more than 4.5V)
40	Vdisp	I	FL power supply. (-27V)	80	KIN2	I	Key data input. (AD input)

■ PD0198A (GYCB ASSY IC105)

● OSD IC

● Block Diagram

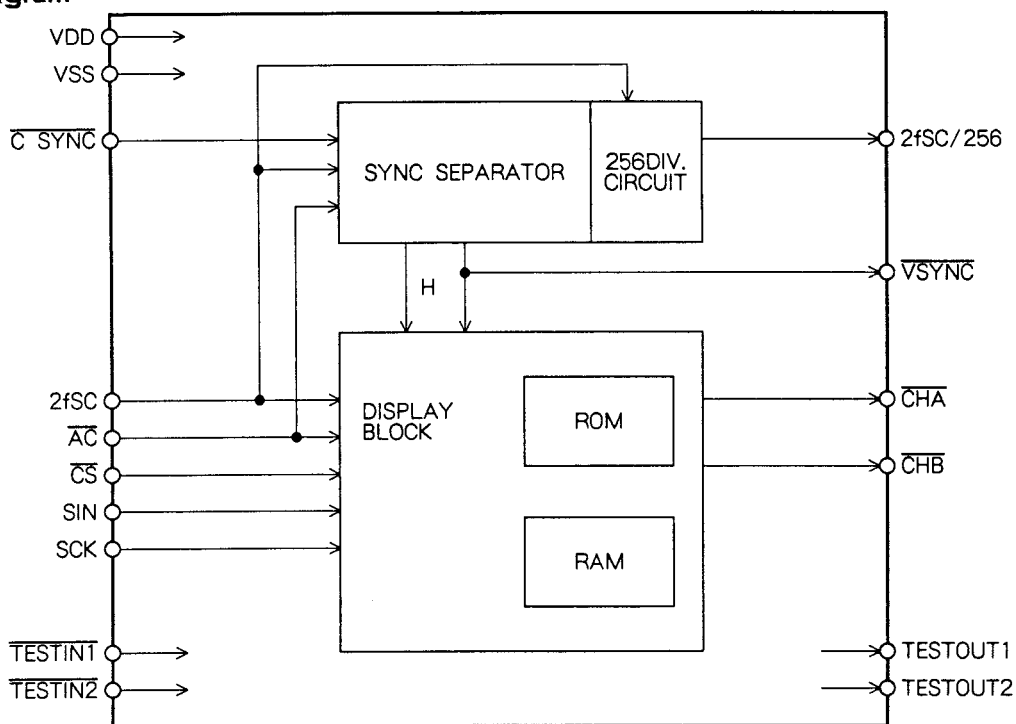

● Pin Function

No.	Name	Pin name	Function
1	TESTIN1	Test input 1	Input pin for IC test with pull-up resistor. Set to open.
2	C SYNC	Composite sync input	Input composite sync signal with negative logic. Schmitt input.
3	TESTIN2	Test input 2	Input pin for IC test with pull-up resistor. Set to open.
4	2fSC	Master clock	Input double clock of color subcarrier frequency. Schmitt input.
5	TESTOUT1	Test output 1	Output pin for IC test. Set to open.
6	CHA	Channel A output	Character timing is output with negative logic.
7	CHB	Channel B output	In the blanking function is ON, logical sum of character timing and blanking timing is output with negative logic.
8	VSS	Ground	Connect to GND.
9	SCK	Serial clock input	Apply a clock when performing the serial communication. Read in the SIN value at rising edge. With pull-up resistor. Schmitt input.
10	SIN	Serial data input	Apply a data when performing the serial communication. With pull-up resistor.
11	CS	Chip select input	Set to "L" when performing the serial communication. with pull-up resistor.
12	AC	Auto clear input	Initialize the IC internal by "L". However, contents of RAM which is memorized character code is not changed.
13	TESTOUT2	Test output 2	Output pin for IC test. Set to open.
14	2fSC/256	Master clock divided by 256 output	Output a clock which master clock (2fsc) is divided by 256.
15	VSYNC	V sync output	Output the signal which pin 2 (C SYNC) signal is separated to V SYNC with negative logic.
16	VDD	Power supply	Connect to +5V.

■ PAC005B (MOTHER ASSY IC400)
• VIDEO IC

● Block Diagram

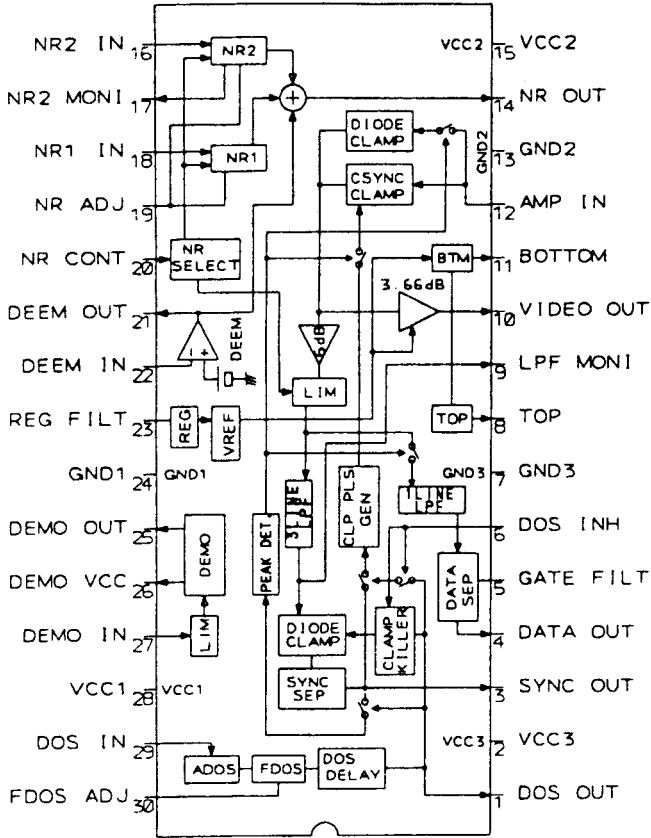

● Pin Function

No.	Pin Name	Function
1	DOS OUT	Drop out pulse output.
2	VCC3	VCC for SYNC SEP section.
3	SYNC OUT	Composite sync output.
4	DATA OUT	Data pulse output.
5	GATE FILT	Connect a capacitor for Gate - Gate.
6	DOS INH	Clamp pulse and clamp killer control.
7	GND3	GND for SYNC SEP section.
8	TOP	Reference DC (TOP) for A/D.
9	LPF MONI	Monitor the LPF for SYNC SEP.
10	VIDEO OUT	Signal output for A/D.
11	BOTTOM	Reference DC (BOTTOM) for A/D.
12	AMP IN	Sync chip clamp input.
13	GND2	GND for VIDEO.
14	NR OUT	Noise reduction output.
15	VCC2	VCC for VIDEO section.
16	NR2 IN	Signal input (2) for noise reduction.
17	NR2 MONI	Limiter output for noise reduction.
18	NR1 IN	Signal input (1) for noise reduction.
19	NR ADJ	Limiter level adjusting pin for noise reduction.
20	NR CONT	Noise reduction (1, 2) select and limiter control.
21	DEEM OUT	De-emphasis output.
22	DEEM IN	De-emphasis input.
23	REG FILT	Connect a capacitor for regulator.
24	GND1	GND for RF section.
25	DEMO OUT	Demodulation output of RF signal.
26	DEMO VCC	VCC for FM demodulation output.
27	DEMO IN	RF input for FM demodulation.
28	VCC1	VCC for RF section.
29	DOS IN	RF input for DOS.
30	FDOS ADJ	FDOS sensitivity adjustment.

■ PD0192A (MOTHER ASSY IC500)
• DIGITAL VIDEO PROCESSOR

● Block Diagram

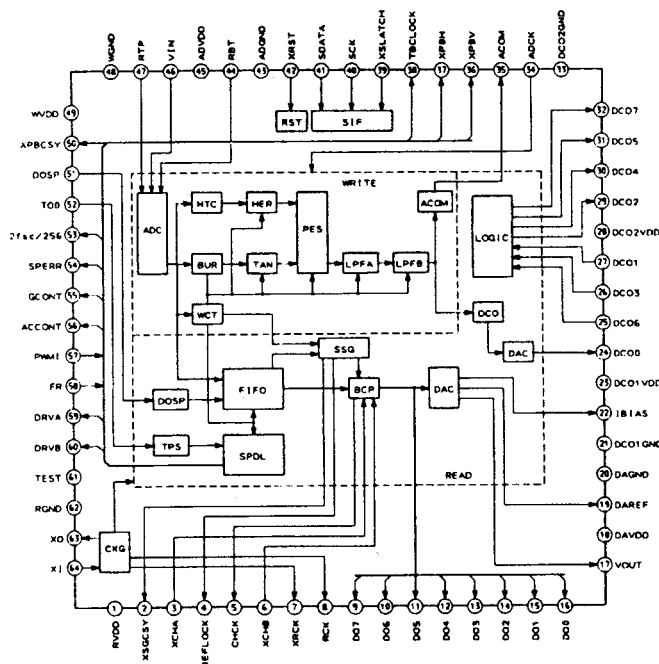

● Pin Function

No.	Pin Name	Function
1	RVDD	Power pin for reference system. Connect to +5V.
2	XSGCSY	Reference composite sync. is output at negative logic. Delay can be controlled by serial command.
3	WFM	MEMSYS : 1 Field monitor output for write system. Outputs "H" when in odd field.
	XCHA	MEMSYS : 0 Character input pin. Inputs "L" during character insertion.
4	XTBCH	MEMSYS : 1 TBC H sync. output. Outputs time base-corrected (TBC) H sync. at negative logic.
	REFLOCK	MEMSYS : 0 SSG phase detection signal output. Outputs "H" when phase difference of H, V sync. between Playbacksystem (after TBC) and SSG system is small enough.
5	XTBCV	MEMSYS : 1 TBC V sync. output. Outputs time base-corrected V sync. at negative logic.
	GHCK	MEMSYS : 0 Clock output for character generator. Output 2fsc.
6	FCH	MEMSYS : 1 Field change input. Switches field of SSG when "H".
	XCHB	MEMSYS : 0 Character frame input pin. Inputs "L" when character frame is inserted.
7	XRCK	Reference CLK is reversed and output.
8	RCK	Reference CLK output.
9	DO7	Data output 7
10	DO6	Data output 6
11	DO5	Data output 5
12	DO4	Data output 4
13	DO3	Data output 3
14	DO2	Data output 2
15	DO1	Data output 1
16	DO0	Data output 0
17	VOUT	DAC output of TBC video signal.
18	DAVDD	Power pin for D/A converter. Connect to +5V.
19	DAREF	D/A converter reference for video. Normally connect to DAGND via 0.1 μ F of laminated ceramic capacitor.
20	DAGND	Ground pin for D/A converter. Connect to GND.
21	DCO1GND	Ground pin for DCO. Connect to GND.
22	IBIAS	Current setting pin of bias circuit. Normally connect to DAGND via external resistor (10k Ω).
23	DCO1VDD	Power pin for DCO. Connect to +5V.

No.	Pin Name	Function
24	DCO0	DCO output pin. ADCK is generated by multiplying this signal by 4.
25	DCO6	Waveform shaping input pin 6. Inputs signal of DCO5 output signal that is delayed 35 ns (self-biased).
26	DCO3	Waveform shaping input pin 3. Inputs signal of DCO2 output signal that is delayed 70 ns (self-biased).
27	DCO1	Waveform shaping input pin 1. Inputs DCO0 signal via band-pass filter of fsc (self-biased).
28	DCO2VDD	Power supply pin for multiplied by 4 section. Connect to +5V.
29	DCO2	Waveform shaping output pin 2. Outputs signal of waveform of DCO1 signal that is shaped.
30	DCO4	Waveform shaping output pin 4. Outputs signal of waveform of DCO3 signal that is shaped.
31	DCO5	Waveform shaping output pin 5. Outputs signal multiplied by 2.
32	DCO7	Waveform shaping output pin 7. Outputs signal multiplied by 4.
33	DCO2GND	Ground pin for multiplied by 4 section. Connect to GND.
34	ADCK	CLK input pin for write system. Inputs signal of DCO7 output signal that is filtered through 4 fsc ceramic filter. (self-biased)
35	ACOM	Jitter correction signal output for analog audio. Used to cancel the jitter of analog audio.
36	XPBV	V sync. output for playback system. Outputs signal that has V sync. separated from pin 50 (XPBCSY) signal at negative logic.
37	XPBH	H sync. output for playback system. Outputs signal that has H sync. separated from pin 50 (XPBCSY) signal at negative logic.
38	TBCLOCK	PLL LOCK detection signal output. Outputs "H" when spindle servo loop and TBC servo loop are locked.
39	XSLATCH	Serial interface latch signal input. Generates timing to latch data that was input to serial interface. (latched at L, Schmitt trigger input)
40	SCK	Serial interface CLK input. CLK input for serial interface. SDATA value is read at rising edge. (Schmitt trigger input)
41	SDATA	Serial interface data input. Inputs data to serial interface. (Schmitt trigger input)
42	XRST	System reset input. Initializes internal registers of IC at negative logic. (Schmitt trigger input)
43	ADGND	Ground pin for A/D converter. Connect to GND.
44	RBT	A/D converter bottom reference input. Inputs bottom reference voltage of A/D converter.
45	ADVDD	Power supply pin for A/D converter. Connect to +5V.
46	VIN	A/D converter input. Inputs composite video signal.
47	RTP	A/D converter top reference input. Inputs top reference voltage of A/D converter.
48	WGND	Ground pin for write system. Connect to GND.
49	WVDD	Power pin for write system. Connect to +5V.
50	XPBCSY	Composite sync. input for playback system. Inputs composite sync. for playback system at negative logic. (Schmitt trigger input)
51	DOSP	Drop out pulse input. Inputs drop out detection pulse at positive logic. (Schmitt trigger input)
52	TOO	Tracking open pulse input. Inputs tracking open pulse at positive logic. (Schmitt trigger input)
53	XI/512	Master clock 512 division output. Outputs clock of master clock (4fsc) that is divided by 512.
54	SPERR	Spindle error PFD error output. Outputs result after performing PFD on PBH and RefH at tri-state.
55	GCONT	Spindle gain control output. Outputs PWM signal according to set value (GD0 - GD3), using serial instructions.
56	ACCNT	Accelerated control output. Outputs acceleration/deceleration signal by forced acceleration/deceleration and PBH sync. frequency detection at tri-state.
57	PWMI	Spindle error PWM input. Inputs signals that have voltage compared between spindle errors that passed through a loop filter and chopping waves. (Schmitt trigger input)
58	FR	Spindle error direction component input. Inputs signals that have voltage compared between spindle errors that passed through a loop filter and target voltage. (Schmitt trigger input)
59	DRVA	Transistor control signal output pin for spindle motor drive. This setting is performed by the interface corresponding to the brush motor and brushless motor.
60	DRVB	Transistor control signal output pin for spindle motor drive. This setting is performed by the interface corresponding to the brush motor and brushless motor.
61	TEST	Input pin for IC test. Fixed to "L".
62	RGND	Ground pin for reference system. Connect to GND.
63	XO	Oscillation output. Connect the X'tal (4 fsc) for oscillation.
64	XI	Oscillation input. Connect the X'tal (4 fsc) for oscillation.

■ PD0212B (MOTHER ASSY IC101)
• MECHANISM CONTROL IC

● Pin Function

No.	Pin Name	I/O	Function
1	VCC	I	Power supply pin. Apply 5V ± 10%.
2	RFCORR	O	RF correction switch signal output. "H"=gain UP CD,CDV - A:Low, CAV inner circuit gain up, others are High.
3	MUTE	O	Audio mute control signal output of audio system. L : Release MUTE , H : MUTE
4	SRDMUTE	O	Mute control signal output for AC3. Release MUTE during playback. L : Release MUTE, H : MUTE
5	TILT ON	O	(For debugging)Tilt operation information. H : during operation for checking tilt operation.
6	TILTERR	I A/D	This signal is A/D converted as the tilt servo control input. Control the tilt motor so that this signal becomes 2.5V.
7	TBALERR	I A/D	Tracking error balance signal input. This signal is A/D converted as the tracking offset control input.
8	SLDERR	I A/D	This signal is A/D converted as the slider servo control input. Control the tilt motor so that this signal becomes 2.5V.
9	SLDPOS	I A/D	Pickup position detection switch input. Detect the position by reading A/D input value which each switches are resistance divided.
10	XFOK	I	Focus servo lock signal input. L : Lock , H : Unlock Use for lock detection of focus servo.
11	SINGLE	I	ATT - SW of rear panel use for the single mode.This information transmit to mode control by communication. L : Single H : Normal
12	TBALDRV	O PWM	Output the tracking offset signal to PWM output, then use for auto tracking offset. 910 μsec period, tri-state control H, L,Z
13	XCD	O	LD/CD switch signal output pin. L : CD H : LD
14	XPLAY	O	Signal output during spindle servo. L : during servo H :during acceleration, brake and stop
15	SQOUT	I	Command data input from DSP. Read out SUBQ.
16	COIN	O	Command data output to DSP.
17	CQCK	O	DSP reading/writing command clock output pin. read at rising edge.
18	SLDDRV	O PWM	Slider control signal output pin. 5V=FWD, 0V=REV, 2.5V=STOP 910 μ sec period, tri-state control H, L, Z
19	SI1	I	Data input from the mode control IC.
20	SO1	O	Serial data output to the mode control IC.
21	SCK1	I/O	Clock for serial communication with the mode control IC. Becomes input mode without communicate with the mode control IC.
22	TZC	I INT	Tracking error zero cross signal input pin. Monitor this signal when searching track count in the miss clamp detection.
23	SHAKE	I/O	Hand shake signal for data communication with the mode control IC. Each microcomputer controls input/output by bilateral data line.
24	TILTDRV	I/O	LOAD/TILT control output pin. 0.5V - tray IN, OUT/tilt DOWN, UP 2.5V - STOP Use for tilt servo that tilt drive is PWM output.
25	XANA	O	Digital/Analog audio switch signal output. L : Analog H : Digital
26	XPBV	I	Playback vertical sync. signal input of LD/CDV. L :during vertical sync.
27	CNVss	I	Ground pin for A/D conversion.
28	XRESET	I	Reset signal input. L : Reset H : Release reset Mode control is controlled.
29	XIN	I	9MHz clock oscillation input pin.
30	XOUT	O	9MHzclock oscillation output pin.
31	N.C.	O	Not used.
32	GND	I	Ground.
33	SW1	I	Switch input for Loading/Tilt position detection
34	SW3	I	
35	SW2	I	

**CLD - V860,
CLD - 2750K**

No.	Pin Name	I/O	Function
36	N.C.	I	Not used.
37	FG	I	Spindle motor FG signal input. 16 outputs per rotation. Used after dividing by 2 in microcomputer.
38	DATA	I	Input pin for Phillips code decoder with built in mechanism controller.
39	XPBH	I	Playback H - SYNC input for Phillips code decoder.
40	XPBV	I	Playback V - SYNC input for Phillips code decoder.
41	TURNA	I	Turn switch input. H : side A L : side B
42	BINSIDE	I	Side B inside switch input. L : Side B inside H : others
43	MEMLAT	O	Serial control latch output of memory control IC (PD4510A). Latches at falling edge.
44	MEMORY	I	Memory yes/no determination input pin. H :memory yes L : memory no
45	DOCINH	O	Control the clamp pulse and clamp killer by tri-state values.
46	DETPOW	I	Use for power abnormal signal input port. L : Normal H : Abnormal
47	NROFF	O	Control output of the noise reduction by VDEM. L : Normal H : Not NR
48	WFM	I	Field determination signal from DVP. L : EVEN H : ODD
49	SQ1	O	Analog audio switch signal output 1/L. L : squelch OFF H : squelch ON
50	SQ2	O	Analog audio switch signal output 2/R. L : squelch OFF H : squelch ON
51	XCX	O	Analog audio CX noise reduction switch signal output. L : CX ON H : CX OFF
52	XVCECAN	O	Voice cancel output. L : CANCEL ON , H : OFF
53	SO3	O	Serial 3 data signal output. Serial signal is commoned, signal distinguish by latch signal (DVPLAT, TLAT).
54	SCK3	O	Serial 3 clock signal output.
55	DVPLAT	O	PD0192A serial latch signal output pin. Latches at falling edge.
56	TBCLOCK	I	Spindle lock signal input pin. L : Unlock , H : Lock
57	TLATCH	O	DAC & digital filter PD2026B serial control latch signal output pin. Latches at falling edge.
58	XREV	O	Side A/side B switch pin. H : side A , L : side B
59	DETAMP	I	Spindle over-current detection signal input pin. L : over current , H : Normal
60	FSEQ	I	Subcode sync. conformity detection signal input pin. L : Not conformity , H : Conformity
61	THOLD	I	Track jump accelerating/decelerating signal input pin. L : other H : accelerating/decelerating
62	WRQ	I	Subcode Q reading OK signal input pin. L : NG , H : OK This pin will be H when Subcode Q data passed by CRC check.
63	RWC	O	DSP read/write command signal output pin. L : READ H : WRITE
64	RWC2	I	Set to input port without influence when this pin short-circuit to pin 63.

■ PDC016A (GYCB ASSY IC103)
• DIGITAL GRAPHICS DECODER for LD

● Block Diagram

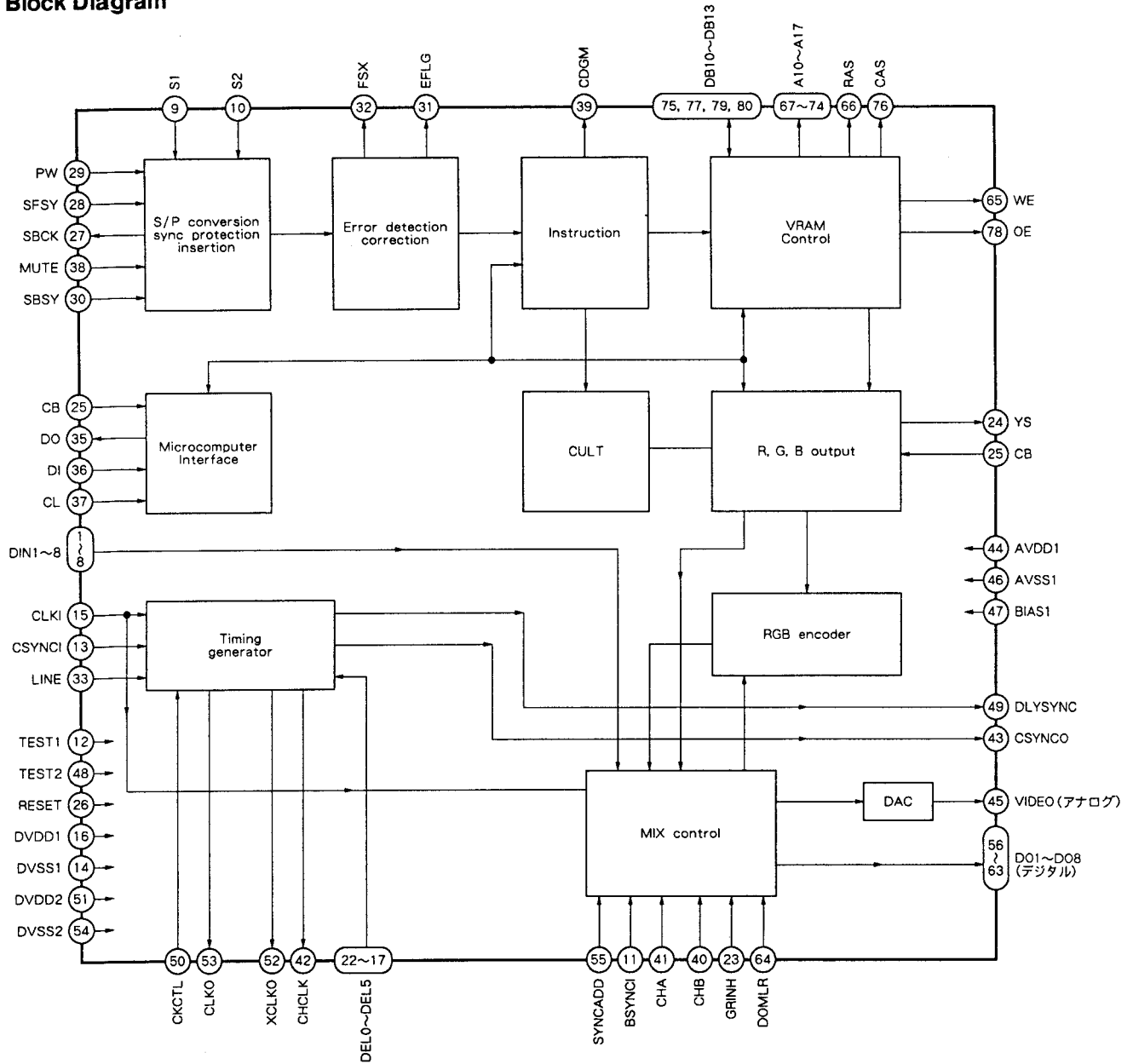

• Pin Function

No.	Name	Pin Name	I/O	Function															
1	DIN8	Video data input pin	I	Digital video data input. (MSB)															
2	DIN7			Digital video data input.															
7	DIN2																		
8	DIN1			Digital video data input. (LSB)															
9	S1	DSP selection pin	I	<table border="1"> <thead> <tr> <th>S1</th> <th>S2</th> <th>Select DSP</th> </tr> </thead> <tbody> <tr> <td>0</td> <td>0</td> <td>LC7861N/67</td> </tr> <tr> <td>0</td> <td>1</td> <td></td> </tr> <tr> <td>1</td> <td>0</td> <td>LC7860K/63</td> </tr> <tr> <td>1</td> <td>1</td> <td>LC7868/69/681/681KE</td> </tr> </tbody> </table>	S1	S2	Select DSP	0	0	LC7861N/67	0	1		1	0	LC7860K/63	1	1	LC7868/69/681/681KE
S1	S2				Select DSP														
0	0	LC7861N/67																	
0	1																		
1	0	LC7860K/63																	
1	1	LC7868/69/681/681KE																	
10	S2																		
11	BSYNCI	Ref. SYNC input pin	I	Reference SYNC signal input for burst phase judgment.															
12	TEST1	Test input pin	I	Test input. Normally, fix to "L".															
13	CSYNCI	Composite sync signal input pin	I	Composite sync signal input.															
14	DVssi	Ground pin	-	Digital system GND.															
15	CLKI	Clock input pin	I	4fsc clock input. (self bias input)															
16	DVbDI	Power supply pin (+5V)	-	Digital system power supply.															
17	DEL5	Amount of delay setting input pin	I	Set the amount of the delay of composite sync signal. (MSB)															
18	DEL4			Set the amount of the delay of composite sync signal.															
21	DEL1																		
22	DEL0			Set the amount of the delay of composite sync signal. (LSB)															
23	GRINH	Graphic INH pin	I	Graphic display INHIBIT control input.															
24	YS	Super impose output pin	O	Super impose control output.															
25	CB	Color bar selection pin	I	"L" : Normal mode, "H" : Color bar output															
26	RESET	Reset input pin	I	Reset signal input.															
27	SBCK	Clock output pin	O	Subcode R-W reading clock output.															
28	SFSY	Sync signal input pin	I	Subcode frame sync signal input.															
29	PW	Data input pin	I	Subcode R-W data input.															
30	SBSY	Sync signal input pin	I	Subcode block sync signal input.															
31	EFLG	Error state monitor output pin	O	Error state monitor signal output.															
32	FSX	Error state monitor trigger pin	O	Error state monitor trigger signal output.															
33	LINE	LINE number selection pin	I	Line number selection input. "H"=263H, "L"=262H(at noninterlace)															
34	CE	Enable input pin	I	Control input of serial input/output data.															
35	DO	Data output pin	O	Serial data output.															
36	DI	Data input pin	I	Serial data input.															
37	CL	Clock input pin	I	Clock input for serial data input/output.															
38	MUTE	Mute pin	I	Control signal input for invaliding the subcode data.															
39	CDGM	Graphic data discrimination output pin	O	This pin becomes "H" when graphic instruction is input. (Reset "L" for command control.)															
40	CHB	OSD data input pin	I	OSD edge data input.															
41	CHA			OSD character data input.															
42	CHCLK	Clock output pin	O	2fsc clock output. (Lock by burst signal)															
43	CSYNCO	Composite sync output pin	O	Composite sync signal output.															
44	AVDDI	Power supply pin (+5V)	-	Analog system power supply.															
45	VIDEO	Composite video signal output	O	Composite video signal output. (8 bit DAC output)															
46	AVssi	Ground	-	Analog system GND.															
47	BIAS1	Capacitor connection pin	O	Connect a capacitor for eliminating the ripple.															

No.	Name	Pin Name	I/O	Function
48	TEST2	Input pin for test	I	Test input. In the normal operation, Error correction logical selection pin. ("H"=PQPQ, "L"=QPQ)
49	$\overline{\text{DLYSYNC}}$	Delayed composite sync output pin	O	Delayed composite sync signal output.
50	CKCTL	Clock polarity selection pin	I	BSYNCl latch selection pin. "H"=FSC4, "L"= $\overline{\text{FSC4}}$ (This pin will be input pin for test at test.)
51	DVDD2	Power supply pin (+5V)	-	Digital system power supply.
52	XCLKO	Inversion clock output pin	O	4fsc inversion clock output.
53	CLKO	Clock output pin	O	4fsc clock output.
54	DVSS2	Ground pin	-	Digital system GND.
55	SYNCADD	CSYNC selection input pin	I	Additional selection input of the composite sync signal to 8 bit input data. "H"=Add, "L"=Not add
56	DO1	Video data output pins	O	Digital composite video signal output. (LSB)
57	DO2			Digital composite video signal output.
62	DO7			Digital composite video signal output. (MSB)
63	DO8			
64	DOMLR	Data inversion selection input pin	I	Inverting selection input of the video digital signal output pin. "H"=Invert (LSB → MSB), "L"=Not invert
65	$\overline{\text{WE}}$	Output pins for DRAM	O	Writing enable signal output of DRAM.
66	$\overline{\text{RAS}}$		O	Line address strobe signal output of DRAM.
67	A10		O	DRAM address (A0) output.
68	A11			DRAM address (A1) output.
69	A12			DRAM address (A2) output.
70	A13			DRAM address (A3) output.
71	A14			DRAM address (A4) output.
72	A15			DRAM address (A5) output.
73	A16			DRAM address (A6) output.
74	A17			DRAM address (A7) output.
75	DB10		I/O	DRAM address (D0) input/output.
76	$\overline{\text{CAS}}$		O	Row address strobe signal output of DRAM.
77	DB11		I/O	DRAM address (D1) input/output.
78	$\overline{\text{OE}}$		O	DRAM reading enable signal output.
79	DB12		I/O	DRAM address (D2) input/output.
80	DB13	I/O	DRAM address (D3) input/output.	

■ LH5P832N-12 (KRAB ASSY IC107)
• 256k Pseudo-SRAM

• Pin Arrangement (Top View)

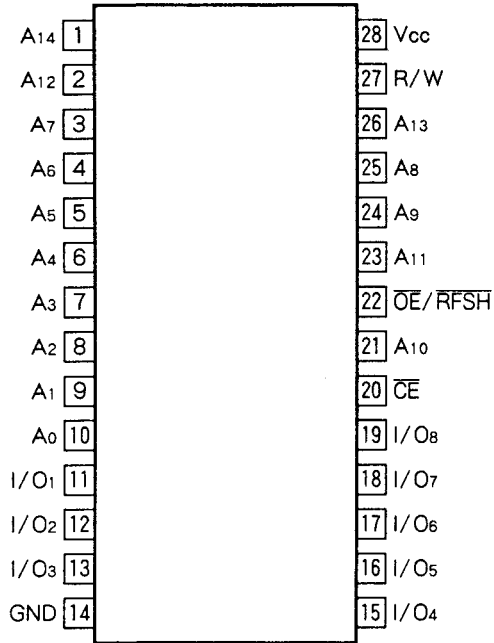

• Pin Function

No.	Pin Name	Function
1-10, 21, 23-26	A0-A14	Address input
27	R/W	Read/write input
22	OE/RFSH	Output enable?refresh
20	CE	Chip enable
11-13, 15-19	I/O1-I/O8	Data input/output
14	GND	Ground
28	Vcc	Power supply

• Block Diagram

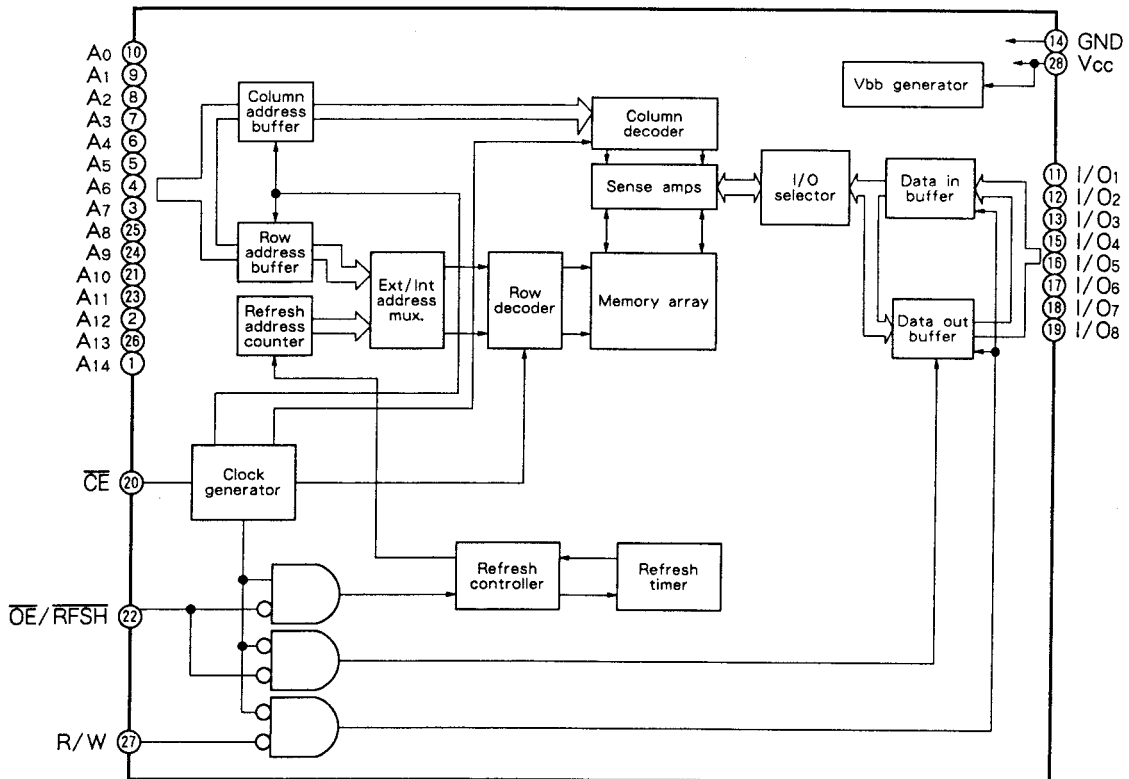

■ PM0007A (KRAB ASSY IC104)
•DASP IC

● Pin Arrangement (Top View)

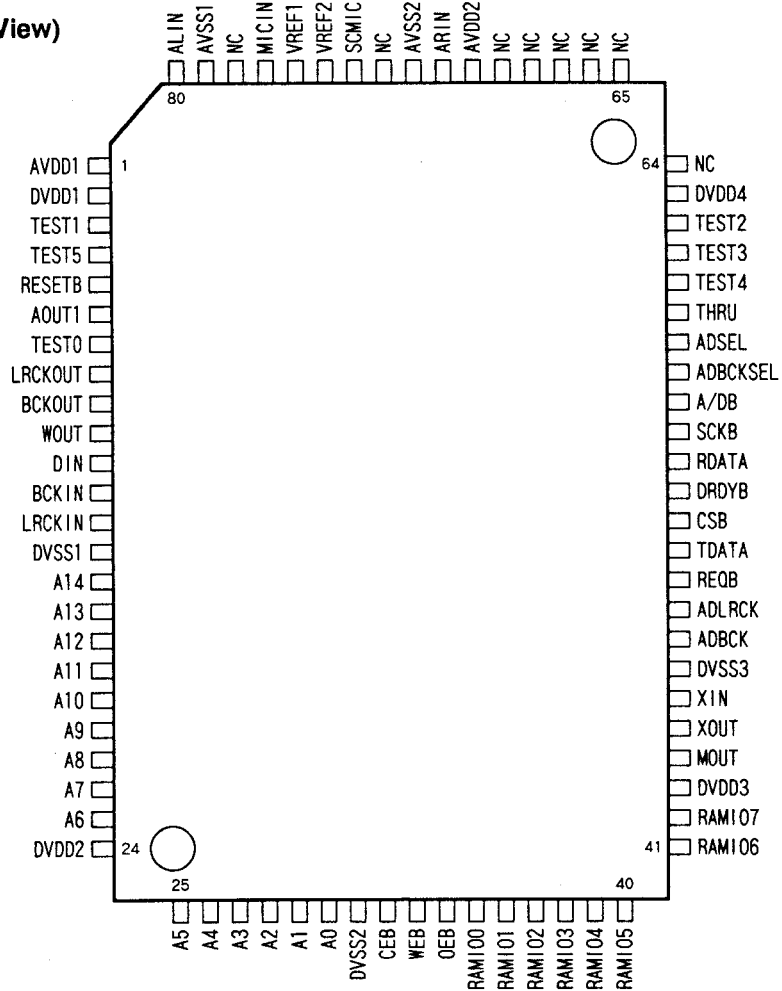

● Block Diagram

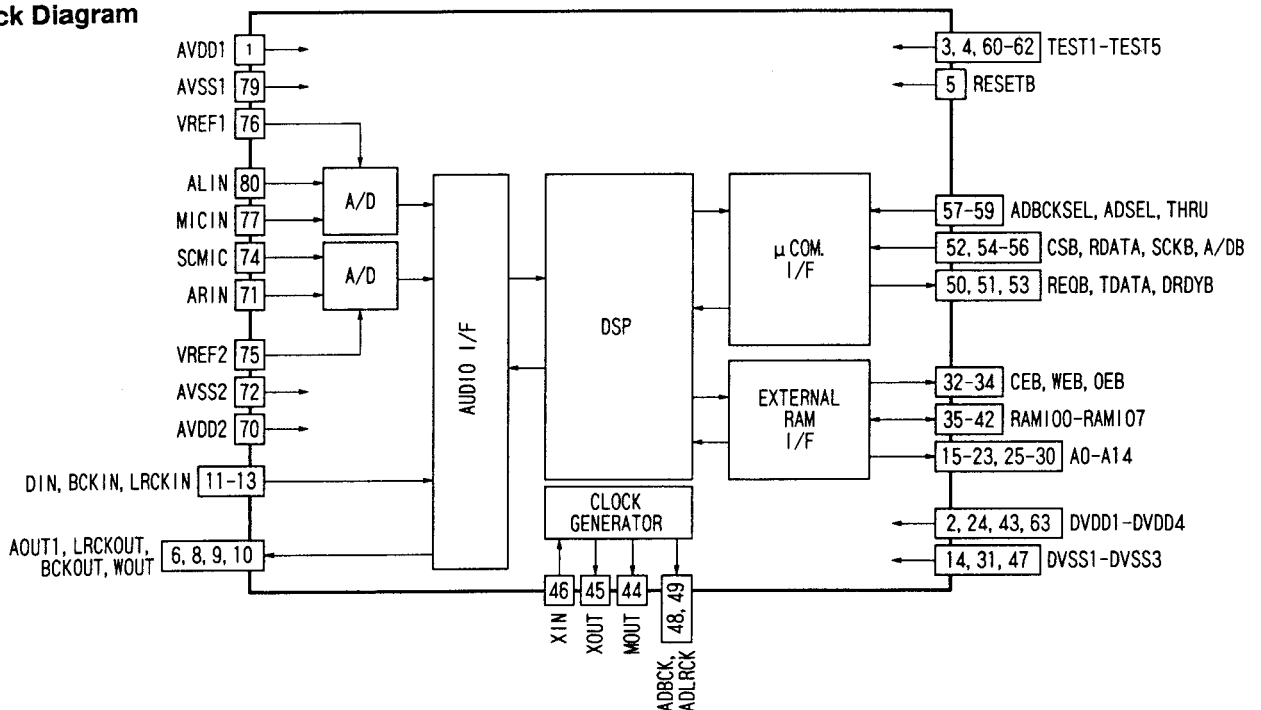

• Pin Function

No.	Name	I/O	Function	No.	Name	I/O	Function
1	AVDD1	-	Power supply pin for A/D converter 1.	43	DVDD3	-	Power supply pin 3 for logical block.
2	DVDD1	-	Power supply pin 1 for logical block	44	MOUT	OC	Master clock output pin.
3	TEST1	IC	Selection input pin for test mode. Normally fixed at "H".	45	XOUT	OCX	Crystal oscillator connection pin.
4	TEST5			46	XIN	ICX	
5	RESETB	IS	Reset input pin. Reset when "L".	47	DVSS3	-	Ground pin 3 for logical block.
6	AOUT	OC	Audio serial data output pin 1.	48	ADBCK	IC	Bit clock output pin for external A/D converter.
7	TEST0	OC	Test data output pin.	49	ADLRCK	IC	LRclock output pin for external A/D converter.
8	LRCKOUT	OC	LR clock output pin. "H": Lch, "L": Rch	50	REQB	OT	Data transfer request output pin for microcomputer.
9	BCKOUT	OC	Bit clock output pin. Outputs 32fs.				
10	WOUT	OC	Word clock output pin.	51	TDATA	OT	Data output pin for microcomputer.
11	DIN	IC	Digital audio input pin.	52	CSB	IC	Chip select input pin for microcomputer interface.
12	BCKIN	IC	Bit clock input pin.	53	DRDYB	OT	Signal receive condition output pin for microcomputer.
13	LRCKIN	IC	LR clock input pin.				
14	DVSS1	-	Ground pin 1 for logical block.	54	RDATA	IC	Serial data input pin from microcomputer.
15	A14	OC	Address output pins for external Pseudo-SRAM.	55	SCKB	IC	Serial clock input pin for receiving data from microcomputer.
16	A13						
17	A12						
18	A11						
19	A10						
20	A9						
21	A8						
22	A7						
23	A6						
24	DVDD2	-	Power supply pin 2 for logical block.	56	A/DB	IC	Address/data judgement pin for data from microcomputer
25	A5						
26	A4						
27	A3						
28	A2						
29	A1						
30	A0						
31	DVSS2	-	Ground pin 2 for logical block.				
32	CEB	OC	Chip enable pin for external Pseudo-SRAM.				
33	WEB	OC	Write enable pin for external Pseudo-SRAM.	58	ADSEL	IC	Digital/Analog audio selection input pin.
34	OEB	OC	Output enable pin for external Pseudo-SRAM.	59	THRU	IC	Setting pin for through mode. Normally fixed at "L".
35	RAMIO0	IOD	Data input/output pins for external Pseudo-SRAM.	60	TEST4	IC	Selection input pins for test mode. Normally fixed at "H".
36	RAMIO1						
37	RAMIO2						
38	RAMIO3						
39	RAMIO4						
40	RAMIO5						
41	RAMIO6						
42	RAMIO7						
31	DVSS2	-	Ground pin 2 for logical block.	61	TEST3	IC	Selection input pins for test mode. Normally fixed at "H".
32	CEB	OC	Chip enable pin for external Pseudo-SRAM.	62	TEST2		
33	WEB	OC	Write enable pin for external Pseudo-SRAM.	63	DVDD4		
34	OEB	OC	Output enable pin for external Pseudo-SRAM.	64	NC	-	Not connected.
35	RAMIO0	IOD	Data input/output pins for external Pseudo-SRAM.	65	NC		
36	RAMIO1						
37	RAMIO2						
38	RAMIO3						
39	RAMIO4						
40	RAMIO5						
41	RAMIO6						
42	RAMIO7						
43	DVDD3	-	Power supply pin 3 for logical block.	66	NC	-	Not connected.
44	MOUT	OC	Master clock output pin.	67	NC		
45	XOUT	OCX	Crystal oscillator connection pin.	68	NC		
46	XIN	ICX					
47	DVSS3	-	Ground pin 3 for logical block.	69	NC		
48	ADBCK	IC	Bit clock output pin for external A/D converter.	70	AVDD2		
49	ADLRCK	IC	LRclock output pin for external A/D converter.	71	ARIN	IA	Rch input pin of analog audio.
50	REQB	OT	Data transfer request output pin for microcomputer.	72	AVSS2	-	Ground pin for A/D converter 2.
51	TDATA	OT	Data output pin for microcomputer.	73	NC	-	Not connected.
52	CSB	IC	Chip select input pin for microcomputer interface.	74	SCMIC	IA	Score microphone input pin.
53	DRDYB	OT	Signal receive condition output pin for microcomputer.	75	VREF2	IAR	Reference voltage input pin for A/D converter 2.
54	RDATA	IC	Serial data input pin from microcomputer.	76	VREF1	IAR	Reference voltage input pin for A/D converter 1.
55	SCKB	IC	Serial clock input pin for receiving data from microcomputer.	77	MICIN	IA	Microphone input pin.
56	A/DB	IC	Address/data judgement pin for data from microcomputer	78	NC	-	Not connected.
57	ADBCKSEL	IC	Output selection input pin for ADBCK pin. 32fs/64fs	79	AVSS1	-	Ground pin for A/D converter 1.
58	ADSEL	IC	Digital/Analog audio selection input pin.	80	ALIN	IA	Lch input pin of analog audio.
59	THRU	IC	Setting pin for through mode. Normally fixed at "L".				
60	TEST4	IC	Selection input pins for test mode. Normally fixed at "H".				
61	TEST3						
62	TEST2						

Note IC : CMOS input
IOD : TTL input, CMOS output, Built-in pull-down resistor
IAR : Analog input, Reference voltage input
OCX : Oscillator, CMOS output
IS : Schmidt input

IO : TTL input, CMOS output
IA : Analog input
ICX : Oscillator, CMOS input
OT : † Tri-state output
OC : CMOS out put

8. BLOCK DIAGRAM

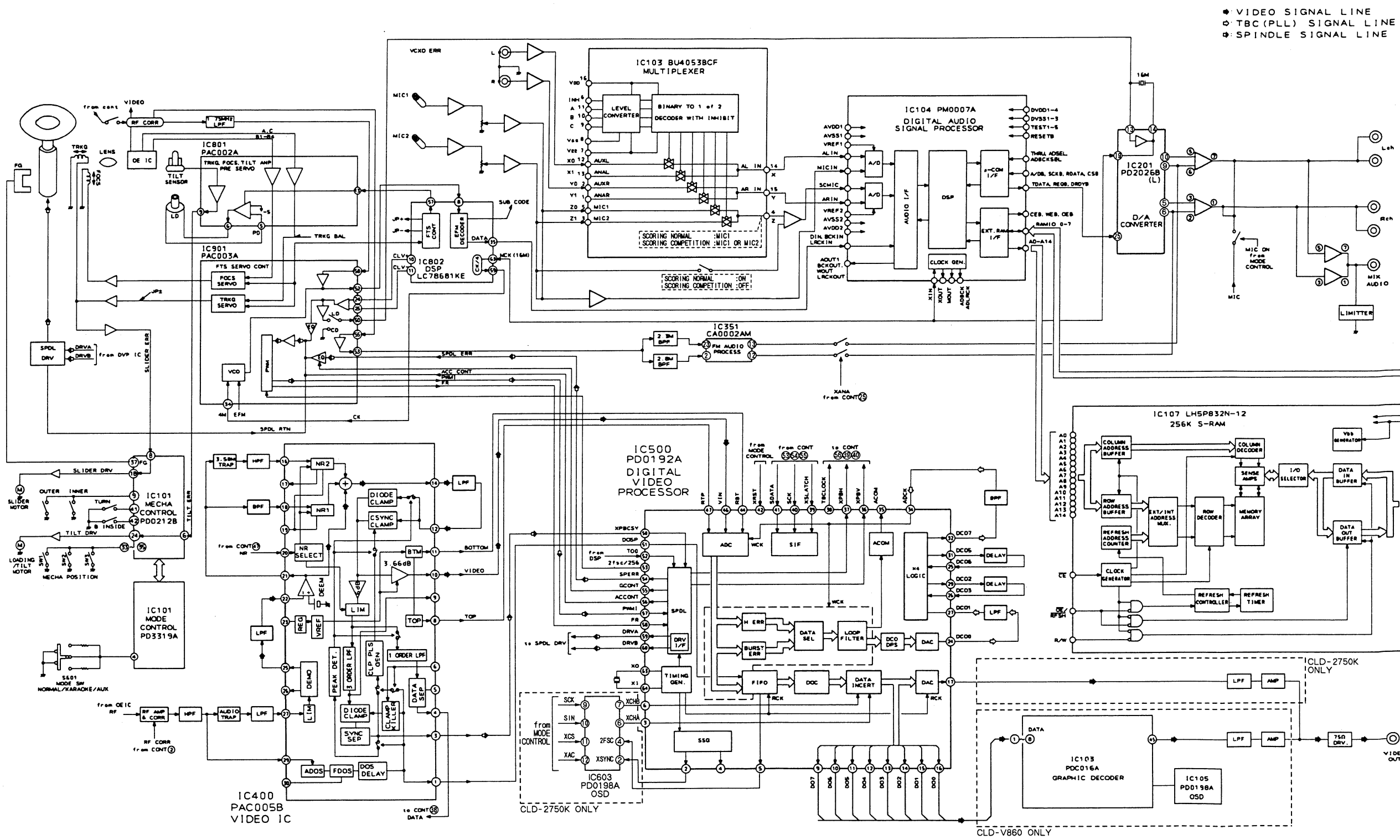

9. PANEL FACILITIES

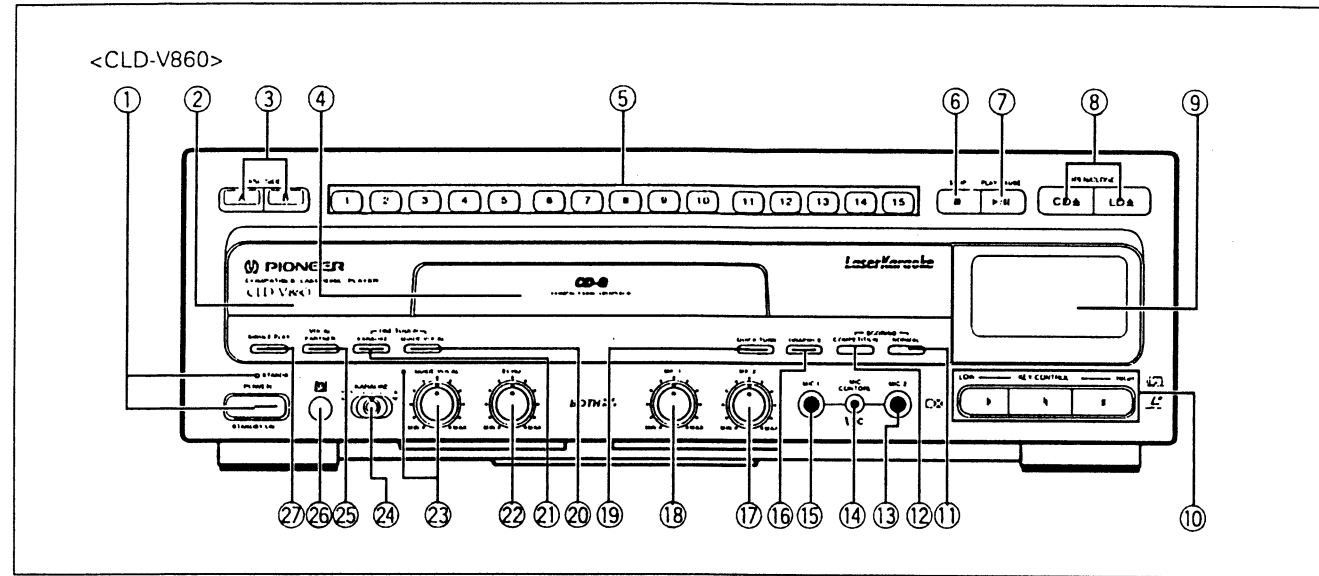

- | | |
|---|---|
| <ul style="list-style-type: none"> ① POWER STANDBY/ON switch and STANDBY indicator
Press to turn the power on and off. ② Disc table ③ DISC SIDE A/SIDE B buttons ④ CD Disc table ⑤ Direct music search buttons ⑥ STOP (■) button ⑦ PLAY/PAUSE (▶/⏸) button ⑧ OPEN/CLOSE (CD ▲/LD ▲) buttons ⑨ Display window ⑩ KEY CONTROL buttons ⑪ SCORING NORMAL button ⑫ SCORING COMPETITION button ⑬ MIC 2 jack | <ul style="list-style-type: none"> ⑭ MIC CONTROL jack ⑮ MIC 1 jack ⑯ GRAPHICS button/indicator (CLD-V860 only) ⑰ MIC 2 level control ⑱ MIC 1 level control ⑲ QUICK TURNON/OFF button/indicator ⑳ ONE-TOUCH GUIDE VOCAL button/indicator ㉑ ONE-TOUCH KARAOKE button/indicator ㉒ ECHO level control ㉓ GUIDE VOCAL level control/indicator ㉔ NORMAL/KARAOKE/AUX INPUT selector ㉕ VOCAL PARTNER button/indicator ㉖ Remote sensor ㉗ SINGLE PLAY button/indicator |
|---|---|

10. SPECIFICATIONS

• CLD - V860

General
 System LaserVision Disc system and Compact Disc digital audio system
 Laser Semiconductor laser wavelength 780 nm
 Power requirements AC 120 V (Switchable), 60 Hz
 Power consumption 36W
 Weight 6.8 kg
 Dimensions 420 (W) x 410 (D) x 132 (H) mm
 Operating temperature +5 °C ~ +35 °C (41 °F ~ 95 °F)
 Operating humidity 5 % ~ 85 %
 (There should be no condensation of moisture.)

Video characteristics (two pairs)
 Format NTSC specifications
 Video output
 Level 1 Vp-p nominal, sync. negative, terminated
 Impedance 75 Ω unbalanced
 Jack RCA jack

Audio characteristics (two pairs)
 Output level
 During analog audio output 200 mVrms (1 kHz, 40 %)
 During digital audio output 200 mVrms (1 kHz, -20 dB)
 Jacks Both RCA jacks
 Number of channels 2 (Stereo)

Other terminals
 Control input/output Both miniature jacks
 AUX RCA jacks
 VHF adapter output (Video/Audio) Both RCA jacks with DC jack

Accessories
 Remote control unit 1
 Size "AAA" (IEC R03) dry cell batteries 2
 Video cord 1
 Audio cord 1
 Operating instructions 1
 Warranty card 1

NOTE:
 The specifications and design of this product are subject to change without notice, due to improvement.

• CLD - 2750K

General
 System LaserVision Disc system and Compact Disc digital audio system
 Laser Semiconductor laser wavelength 780 nm
 Power requirements AC 110 - 127/220 - 240 V 50/60 Hz
 Power consumption 36 W
 Weight 6.7 kg
 Dimensions 420 (W) x 410 (D) x 132 (H) mm
 Operating temperature +5 °C ~ +35 °C
 Operating humidity 5 % ~ 85 %
 (There should be no condensation of moisture.)

Video characteristics (two pairs)
 Format NTSC specifications
 Video output
 Level 1 Vp-p nominal, sync. negative, terminated
 Impedance 75 Ω unbalanced
 Jack RCA jack

Audio characteristics (two pairs)
 Output level
 During analog audio output 200 mVrms (1 kHz, 40 %)
 During digital audio output 200 mVrms (1 kHz, -20 dB)
 Jacks Both RCA jacks
 Number of channels 2 (Stereo)

Other terminals
 Control input/output Both miniature jacks
 AUX RCA jacks
 VHF adapter output (Video/Audio) Both RCA jacks with DC jack

Accessories
 Remote control unit 1
 Size "AAA" (IEC R03) dry cell batteries 2
 Video cord 1
 Audio cord 1
 Power cord 1
 Operating instructions 1
 Warranty card 1

NOTE:
 The specifications and design of this product are subject to change without notice, due to improvement.