

Service Manual

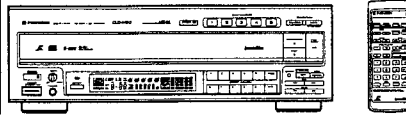

ORDER NO.
ARP2306

LD CD CDV PLAYER

CLD-M90

This manual is applicable to the KUC and SD types.

- As to the SD type, refer to page 117.

CONTENTS

1. SAFETY INFORMATION	2	7. DISASSEMBLY	75
2. PACKING	3	8. ADJUSTMENT	83
3. EXPLODED VIEWS AND PARTS LIST	4	9. MECHANICAL DESCRIPTION	107
4. P.C. BOARDS LOCATION	26	10. FOR SD TYPE	117
5. SCHEMATIC DIAGRAM AND P.C. BOARDS CONNECTION DIAGRAM	27	11. PANEL FACILITIES	120
6. ELECTRICAL PARTS LIST	69	12. SPECIFICATIONS	123

PIONEER ELECTRONIC CORPORATION 4-1, Meguro 1-Chome, Meguro-ku, Tokyo 153, Japan
PIONEER ELECTRONICS SERVICE INC. P.O. Box 1760, Long Beach, California 90801 U.S.A.
PIONEER ELECTRONICS OF CANADA, INC. 505 Cochrane Drive, Markham, Ontario L3R 8E3 Canada
PIONEER ELECTRONIC [EUROPE] N.V. Keetberglaan 1, 9120 Beveren, Belgium
PIONEER ELECTRONICS AUSTRALIA PTY. LTD. 178-184 Boundary Road, Braeside, Victoria 3195, Australia TEL: [03] 580-9911

FJ JULY, 1991 Printed in Japan

This service manual is intended for qualified service technicians; it is not meant for the casual do-it-yourselfer. Qualified technicians have the necessary test equipment and tools, and have been trained to properly and safely repair complex products such as those covered by this manual.

Improperly performed repairs can adversely affect the safety and reliability of the product and may void the warranty. If you are not qualified to perform the repair of this product properly and safely, you should not risk trying to do so and refer the repair to a qualified service technician.

WARNING

Lead in solder used in this product is listed by the California Health and Welfare agency as a known reproductive toxicant which may cause birth defects or other reproductive harm (California Health & Safety Code, Section 25249.5).

When servicing or handling circuit boards and other components which contain lead in solder, avoid unprotected skin contact with the solder. Also, when soldering do not inhale any smoke or fumes produced.

1. SAFETY INFORMATION

(FOR USA MODEL ONLY)

1. SAFETY PRECAUTIONS

The following check should be performed for the continued protection of the customer and service technician.

LEAKAGE CURRENT CHECK

Measure leakage current to a known earth ground (water pipe, conduit, etc.) by connecting a leakage current tester such as Simpson Model 229-2 or equivalent between the earth ground and all exposed metal parts of the appliance (input/output terminals, screwheads, metal overlays, control shaft, etc.). Plug the AC line cord of the appliance directly into a 120V AC 60Hz outlet and turn the AC power switch on. Any current measured must not exceed 0.5mA.

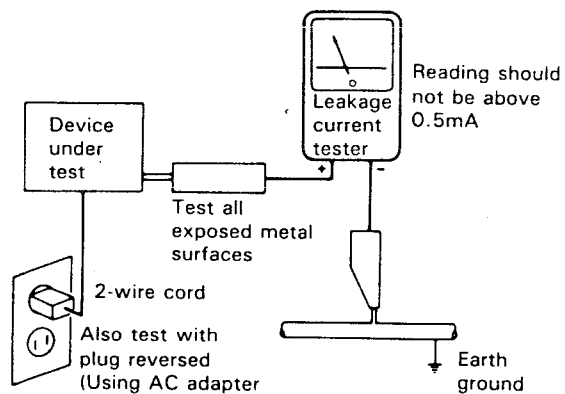

AC Leakage Test

ANY MEASUREMENTS NOT WITHIN THE LIMITS OUTLINED ABOVE ARE INDICATIVE OF A POTENTIAL SHOCK HAZARD AND MUST BE CORRECTED BEFORE RETURNING THE APPLIANCE TO THE CUSTOMER.

2. PRODUCT SAFETY NOTICE

Many electrical and mechanical parts in the appliance have special safety related characteristics. These are often not evident from visual inspection nor the protection afforded by them necessarily can be obtained by using replacement components rated for voltage, wattage, etc. Replacement parts which have these special safety characteristics are identified in this Service Manual.

Electrical components having such features are identified by marking with a Δ on the schematics and on the parts list in this Service Manual. The use of a substitute replacement component which does not have the same safety characteristics as the PIONEER recommended replacement one, shown in the parts list in this Service Manual, may create shock, fire, or other hazards.

Product Safety is continuously under review and new instructions are issued from time to time. For the latest information, always consult the current PIONEER Service Manual. A subscription to, or additional copies of, PIONEER Service Manual may be obtained at a nominal charge from PIONEER.

2. PACKING

Parts List

Mark No.	Description	Parts No.	Mark No.	Description	Parts No.
1.	Connection cord	VDE-055	51.	Dry cell battery(R03,AAA)	
2.	Video cable	VDE-056	52.	Polyethylene bag	
3.	Operating instructions (English)	VRB1063	53.	Caution card	
4.	Remote control unit	VXX1542	54.	Caution card(UC)	
5.	Pad(F)	VHA1084			
6.	Pad(R)	VHA1085			
7.	Packing case	VHG1168			
8.	Mirror mat	VHL1012			
9.	Battery cover	VNK1807			

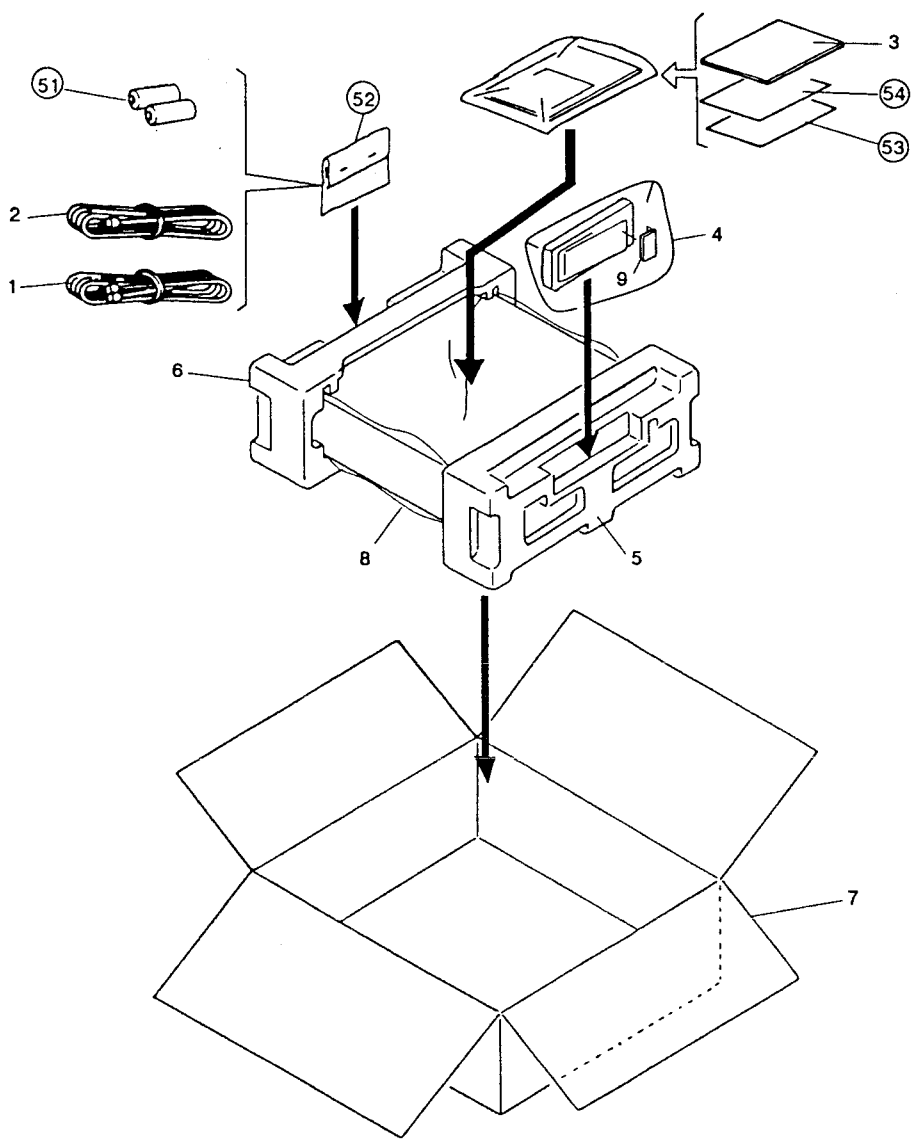

3. EXPLODED VIEWS AND PARTS LIST

NOTES :

- The parts with an encircled number are generally unavailable because they are not in our Master Spare Parts List.
- The Δ mark found on some component parts indicates the importance of the safety factor of the part. Therefore, when replacing, be sure to use parts of identical designation.
- Parts marked by "⊙" are not always kept in stock. Their delivery time may be longer than usual or they may be unavailable.

3. 1 EXTERIOR SECTION

Parts List

Mark	No.	Description	Parts No.	Mark	No.	Description	Parts No.
	1.	Screw	BCZ40P060FZK		101	
	2.	Screw	BBZ30P080FCC		102	65 label	
	3.	Screw	BPZ30P200FMC		103	Cushion	
	4.	CD pad	VEC1252		104	Tray metal	
	5.	LD pad(L)	VEC1472		105	
	6.	LD pad(S)	VEC1473		106	Tray	
	7.	Tray sheet	VEC1474		107	Tray reinforced plate	
	8.	Screw	BPZ30P060FCU				
	9.	Screw	BPZ30P200FMC				
	10.	Bonnet-S	VXX1668				
	11.	Tray assembly-S	VXX1627				

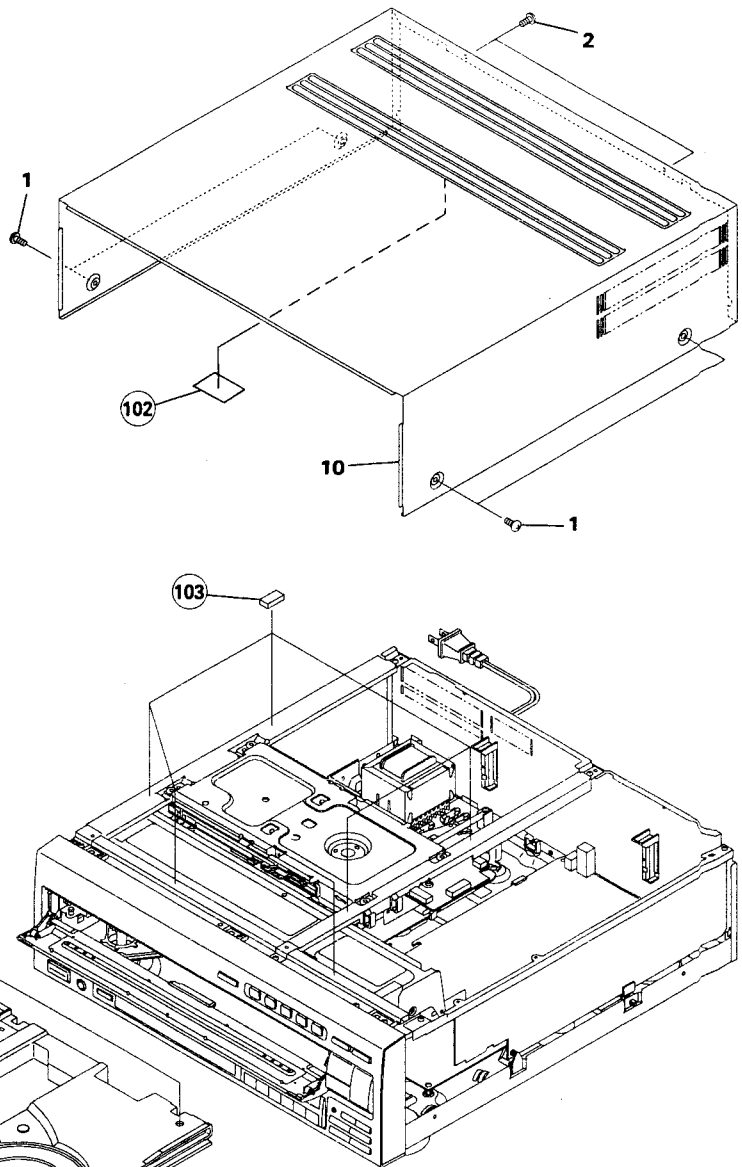
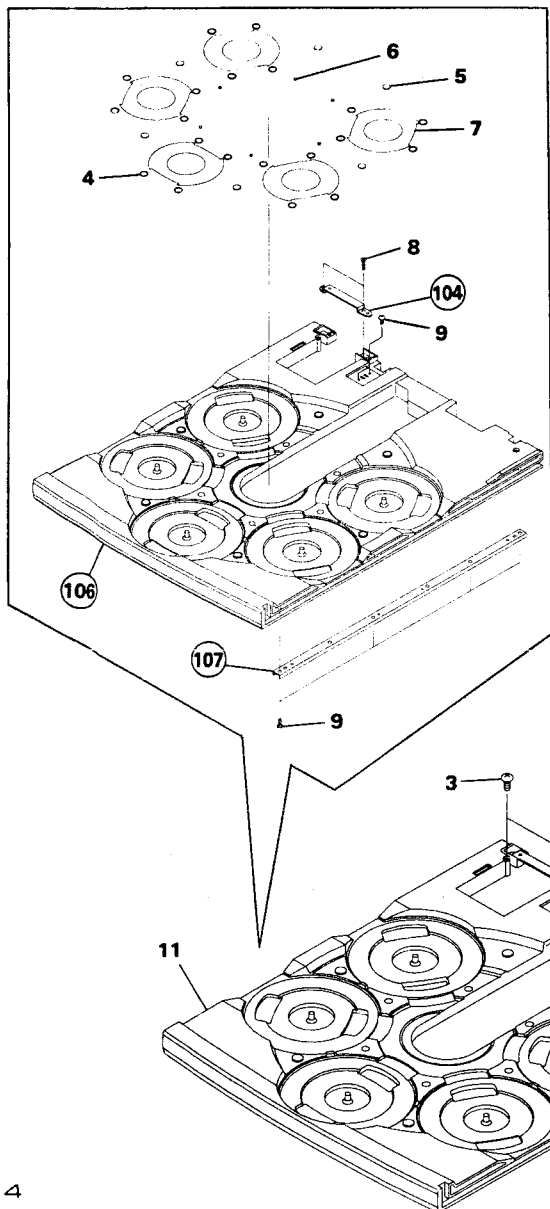

4

1

2

3

3. 2 FRONT PANEL SECTION

A

B

C

D

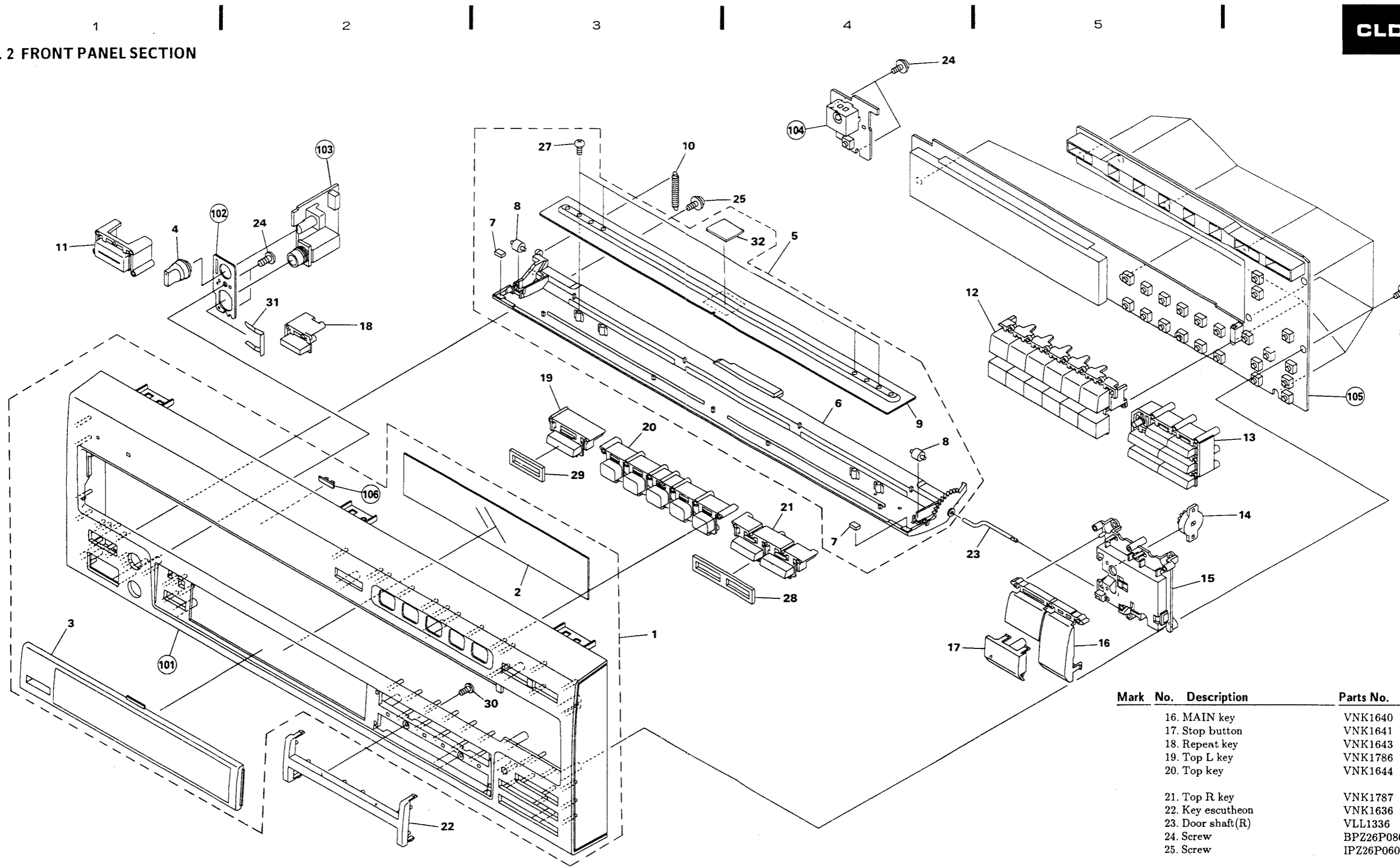

Parts List

Mark No.	Description	Parts No.
1.	Front panel assembly-S	VXX1702
2.	FL filter	VEC1448
3.	FL lens	VNK1645
4.	Volume knob	VNK1658
5.	Door assembly-s	VXX1587

Mark No.	Description	Parts No.
6.	Door assembly	VXA1570
7.	Door dump rubber	VEB1141
8.	Roller	VNL1042
9.	Door Plate	VNE1769
10.	Door Spring	VBH1136
11.	PW button	VNK1649
12.	Ten key	VNK1639
13.	Mode key	VNK1642
14.	Dumper assembly	VXA1053
15.	Sub panel	VNK1637

Mark No.	Description	Parts No.
16.	MAIN key	VNK1640
17.	Stop button	VNK1641
18.	Repeat key	VNK1643
19.	Top L key	VNK1786
20.	Top key	VNK1644
21.	Top R key	VNK1787
22.	Key escutcheon	VNK1636
23.	Door shaft(R)	VLL1336
24.	Screw	BPZ26P080FM C
25.	Screw	IPZ26P060FM C
26.	Screw	IPZ26P060FM C
27.	Screw	BPZ20P040Z K
28.	Cushion A	VEC1455
29.	Cushion B	VEC1456
30.	Screw	BPZ20P060Z C U
31.	Snap plate	VNE1102
32.	Door pad	VEC1530
101.	Front panel	
102.	Jack holder	
103.	HEPB assembly	
104.	PSWB assembly	
105.	FLKY assembly	
106.	Reinforced plate	

6

6

3.3 TOP VIEW SECTION

Parts List

Mark	No.	Description	Parts No.
	1.	Screw	BBZ30P060FCC
	2.	Screw	BBZ30P080FCC
	3.	Screw	BBZ30P060FMC
	4.	Screw	IBZ30P060FCC

101 PCB holder

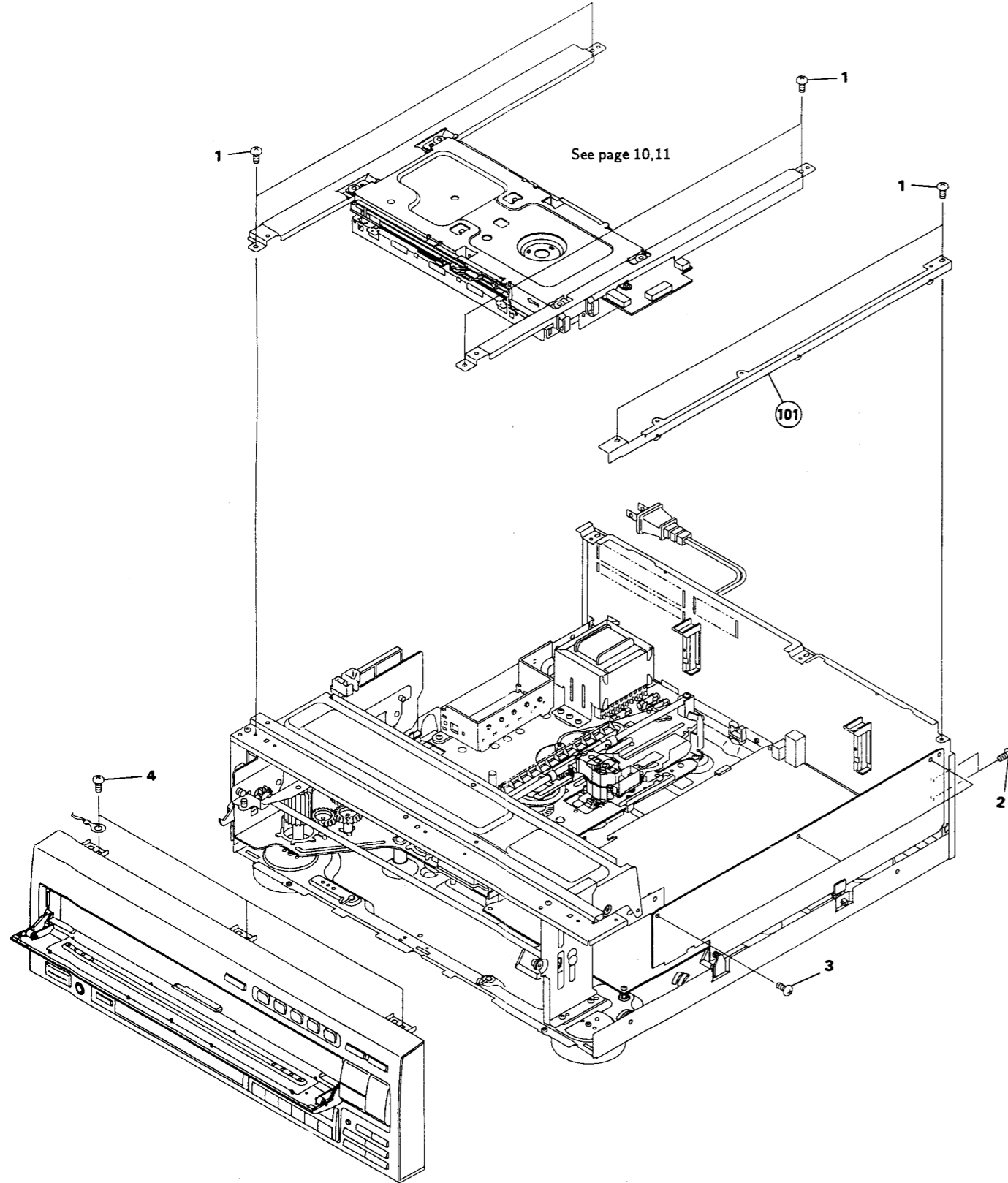

3.4 CLAMPER ARM SECTION

Parts List

Mark	No.	Description	Parts No.
	1.	Holding spring	VBK1031
	2.	Steel ball	PBP-001
	3.	Screw	VBA1026
	4.	Screw	BPZ26P060FMC
	5.	Screw	BBZ30P060FMC
	6.	
	7.	Clamp cam	VNL1393
	8.	Clamp shaft	VLL1342
	9.	Arm base	VNE1640
	10.	Clamper Spring	VBH1184
	11.	Rubber bushing	VEB1164
	12.	
	13.	Limiter plate	VNE1637
	14.	Slide plate	VNE1638
	15.	Limiter spring	VBH1182
	16.	Pivot screw	VBA1022
	17.	Washer	WT26D060D050
	18.	Screw	BPZ26P060FCU
	19.	Lever (A) assembly	VXA1607
	20.	Lever (B) assembly	VXA1608
	21.	Lever (D) assembly	VXA1610
	22.	Center plate assembly	VXA1606
	23.	Lever (C) assembly	VXA1609
	24.	E ring	YE40FUC
	25.	Rubber bushing	VEB1164
	26.	Arm assembly	VWT1071
	27.	Guide sheet	VEC1521
	101.	Angle(L)	
	102.	Center angle	
	103.	Wire clip	
	104.	
	105.	SR board assembly	
	106.	Center plate assembly	

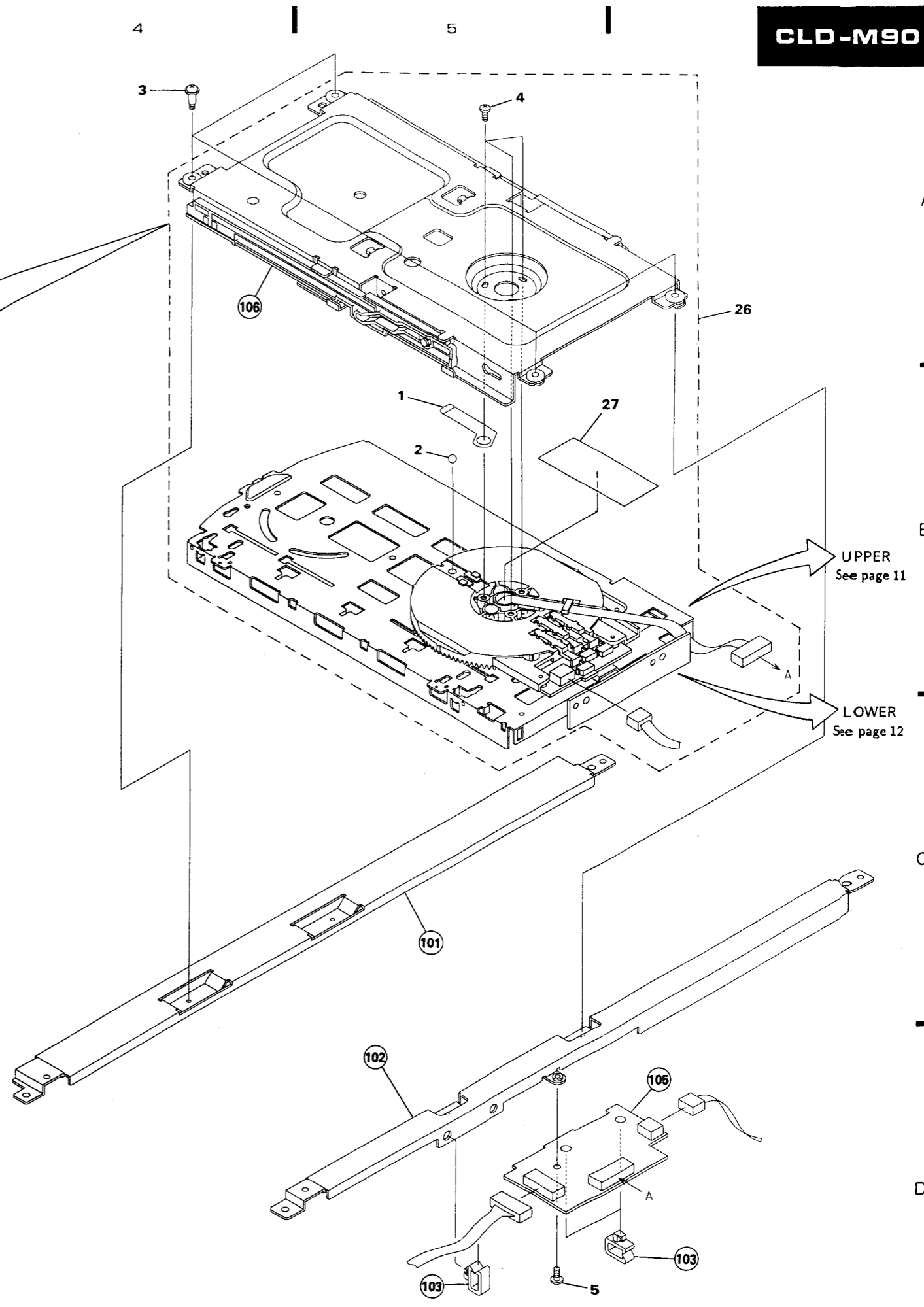
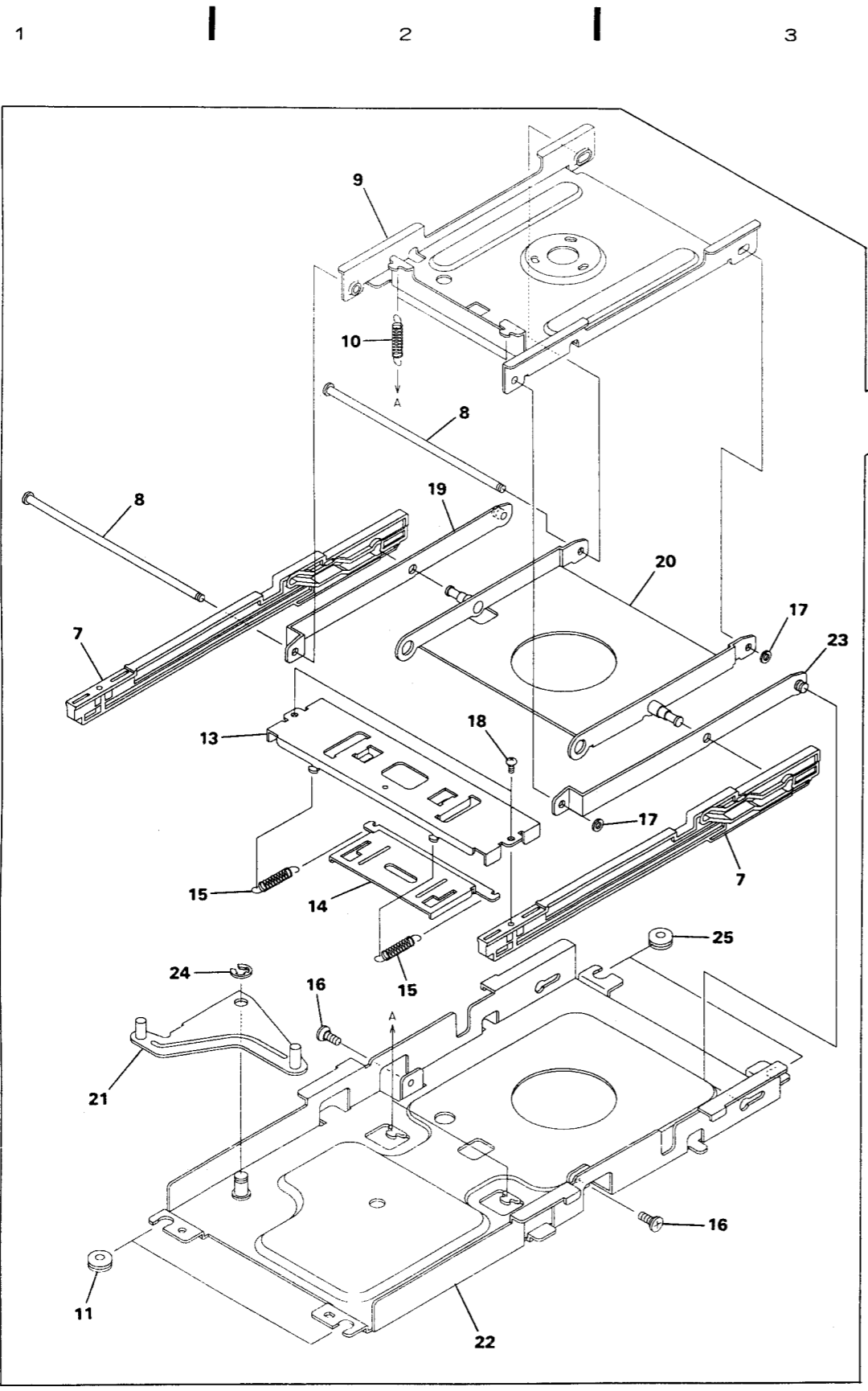

3. 5 CLAMPER ARM (UPPER)

Parts List

Mark	No.	Description	Parts No.
A	1.	Screw	BBZ26P060FMC
	2.	SW lever	VNL1394
	3.	Base gear	VNL1392
	4.	Screw	BPZ26P060FCU
	5.	SW cam	VNL1383
	6.	Plate spring	VBK1022
	7.	Steel ball	VNX1006
	8.	Retainer	VNE1639
	9.	Screw	BBZ26P040FMC
	10.	Arm guide	VNL1405
		101	TD board assembly
		102	FR board assembly

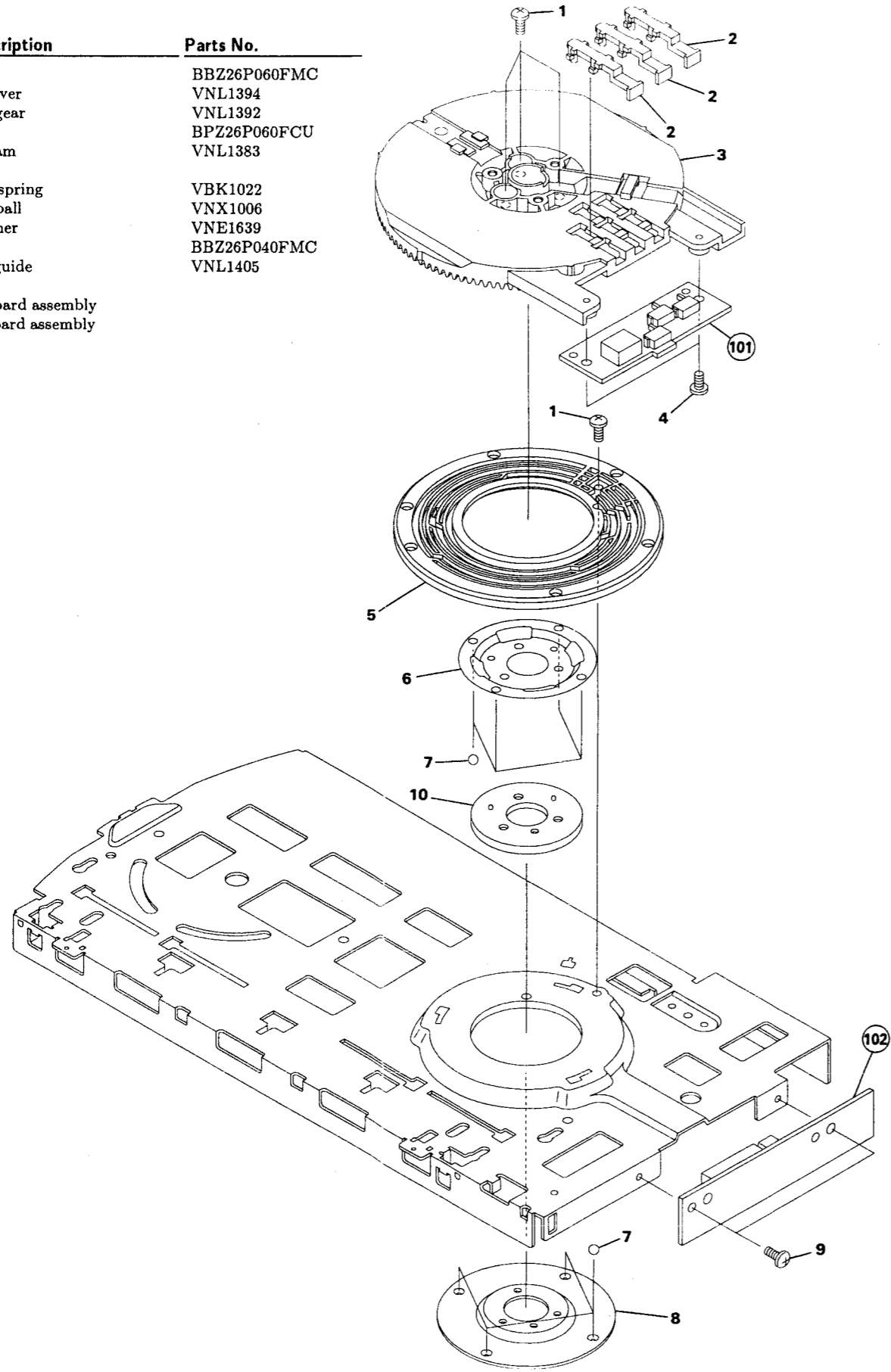

3. 6 CLAMPER ARM (LOWER)

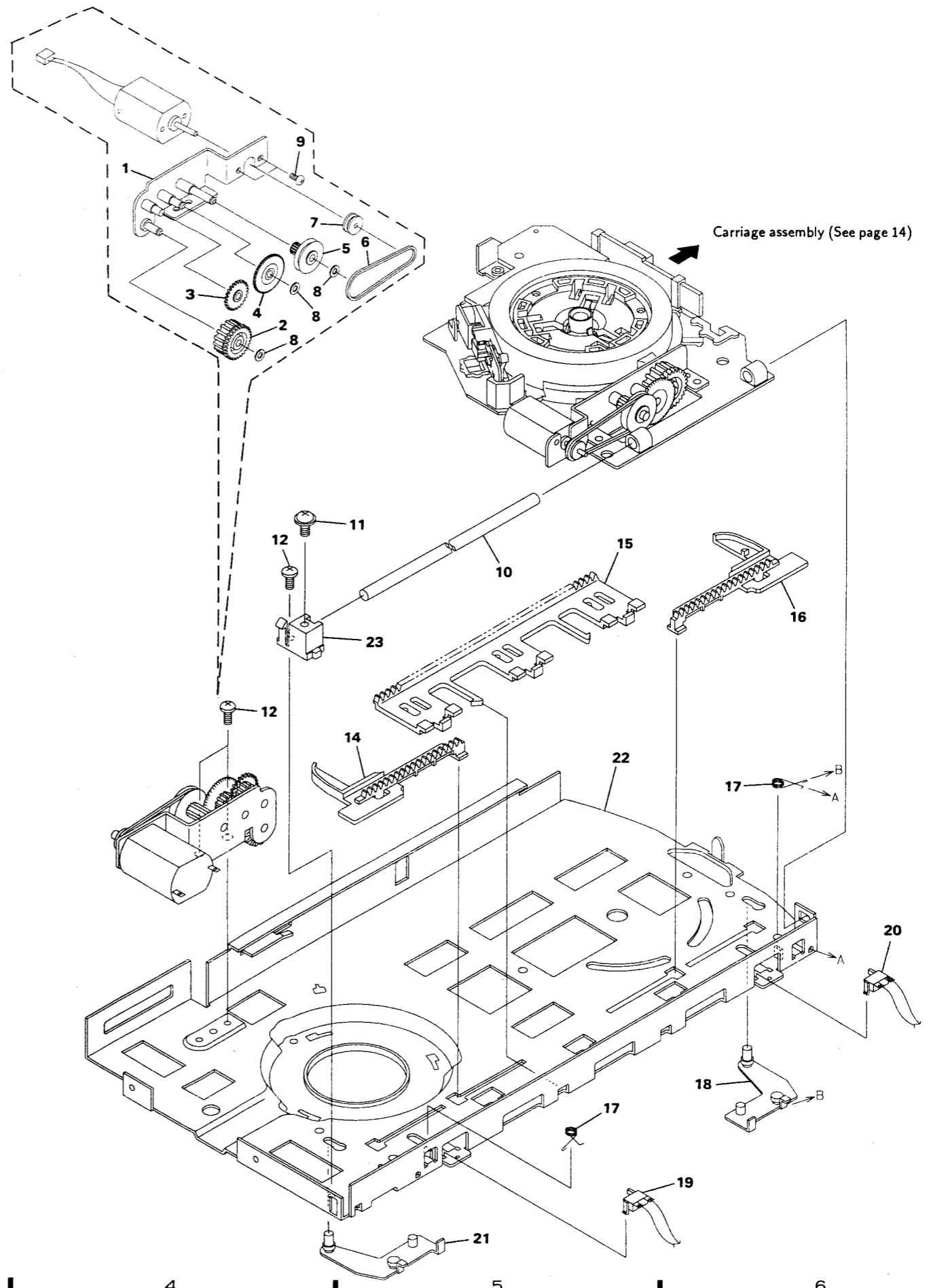

3. 7 CARRIAGE ASSEMBLY

Parts List

Mark No.	Description	Parts No.
1.	M holder (T) assembly	VXA1596
2.	Gear (C)	VNL1378
3.	Idler gear	PNW1098
4.	Gear (A)	VNL1376
5.	Gear pulley	VNL1375
6.	Belt	DEB1104
7.	Motor pulley (T)	VLL1357
8.	Washer	WT26D047D025
9.	Screw	PMA20P040FMC
10.	Guide shaft	VLL1341
11.	Screw	IPZ30P060FMC
12.	Screw	BBZ26P040FMC
13.	
14.	Slide rack (R)	VNL1382
15.	Rack	VNL1380
16.	Slide rack (F)	VNL1381
17.	Lever spring	VBH1156
18.	Change lever (F) assembly	VXA1598
19.	SW (IN)	DSG1014
20.	SW (OUT)	DSG1014
21.	Change lever (R) assembly	VXA1599
22.	Rotate arm	VNE1631
23.	Shaft holder	VNL1384

Parts List

Mark No.	Description	Parts No.
1.	Sensor spring	VBH1158
2.	Sensor lever	VNL1390
3.	Clamper holder	VNL1386
4.	Slider	VNL1388
5.	Lock plate	VBK1028
6.	Inside cam	VNL1389
7.	Ball holder	VNL1289
8.	Rubber sheet	VEB1114
9.	Plate spring(C)	VBK1025
10.	Steel ball	VNX1010
11.	Lever spring(C)	VBH1165
12.	Screw	BBZ26P040FMC
13.	Screw	BPZ26P060FCU
14.	Sensor base assembly	VXA1601
15.	Cam lever assembly	VXA1600
16.	Carriage assembly	VXA1602
17.	Holder Spring	VBH1162
18.	CD holder	VNL1387
19.	Disc Clamper	VNL1385
20.	Gear(C)	VNL1378
21.	Gear(A)	VNL1376
22.	Gear pulley	VNL1375
23.	Belt	DEB1104
24.	Screw	PMA20P040FMC
25.	M holder (C) assembly	VXA1597
26.	Screw	CPZ20P050FMC
27.	Stabilizer	VNE1749
28.	Sensor switch	DSG1014
29.	Washer	WT26D047D025
101.	Housing assembly	
102.	Carriage motor	
103.	Motor pulley (C)	
104.	Carriage motor assembly	
105.	CF+CS assembly	

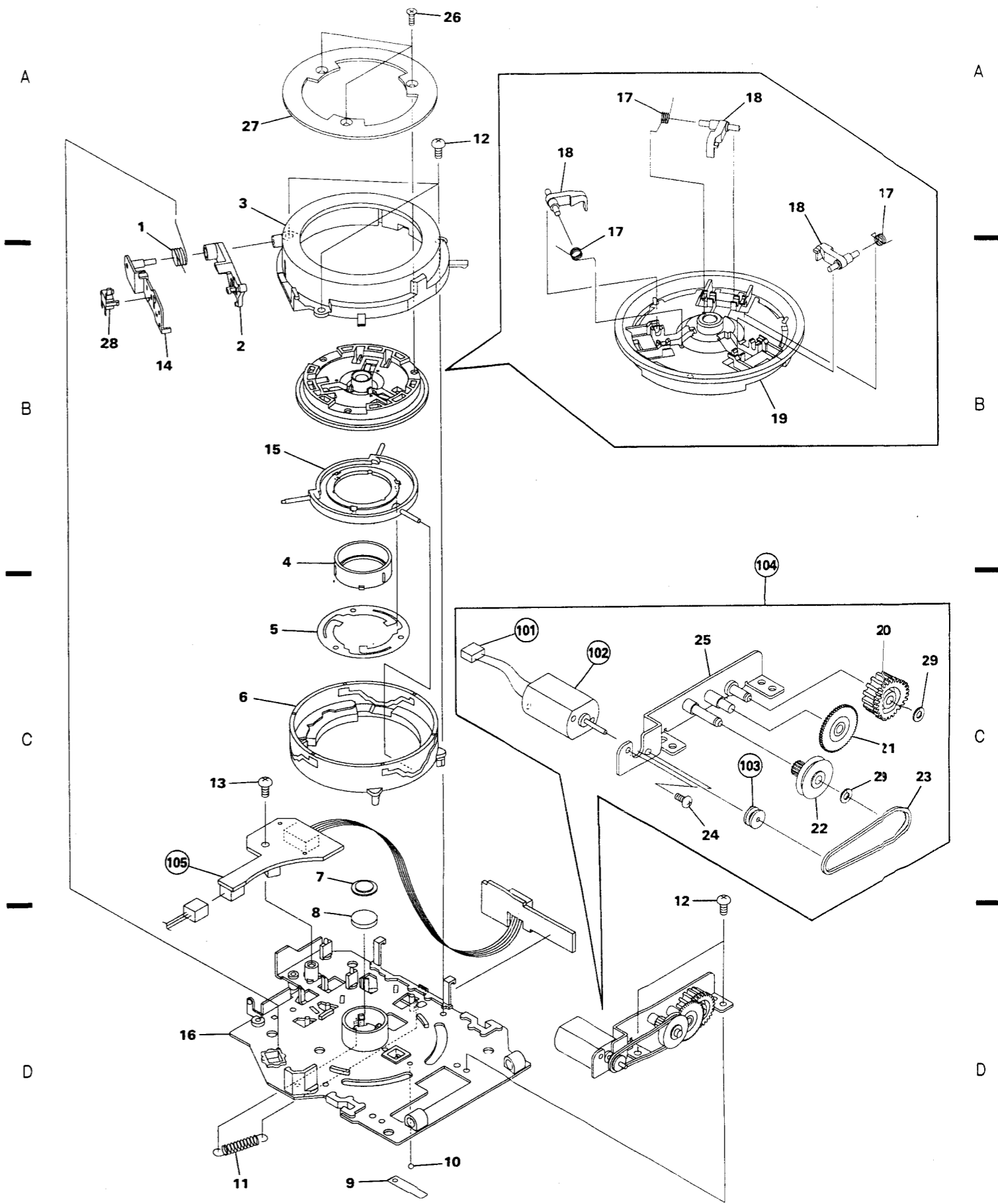

3.8 BASE SECTION (1)

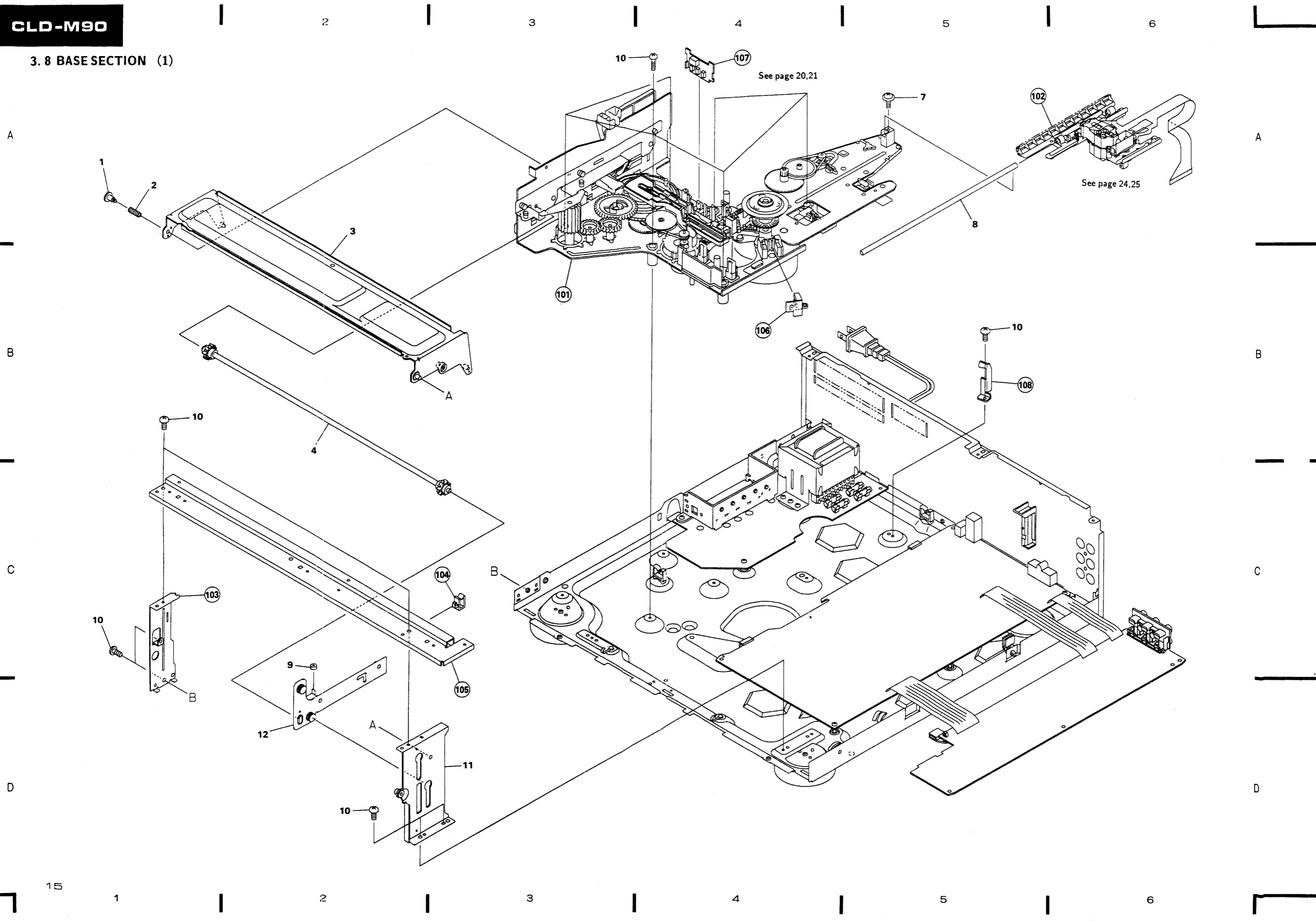

Parts List

Mark	No.	Description	Parts No.	Mark	No.	Description	Parts No.
	1.	Screw(B)	VBA1008		101	Mechanism assembly	
	2.	Arm spring	VBH1093		102	Rack assembly	
	3.	Synchronized arm assembly	VXA1771		103	Side stay (L)	
	4.	Synchronized gear assembly	VXA1605		104	Wire clip	
	5.			105	Front angle	
	6.			106	FG board assembly	
	7.	Screw (B)	VBA1018		107	SW board assembly	
	8.	Carriage shaft	VLL1177		108	SM head stopper	
	9.	Stop ring	VEB1091				
	10.	Screw	BBZ30P060FCC				
	11.	Stay (R) assembly	VXA1603				
	12.	Roller board (R) assembly	VXA1772				

3.9 BASE SECTION (2)

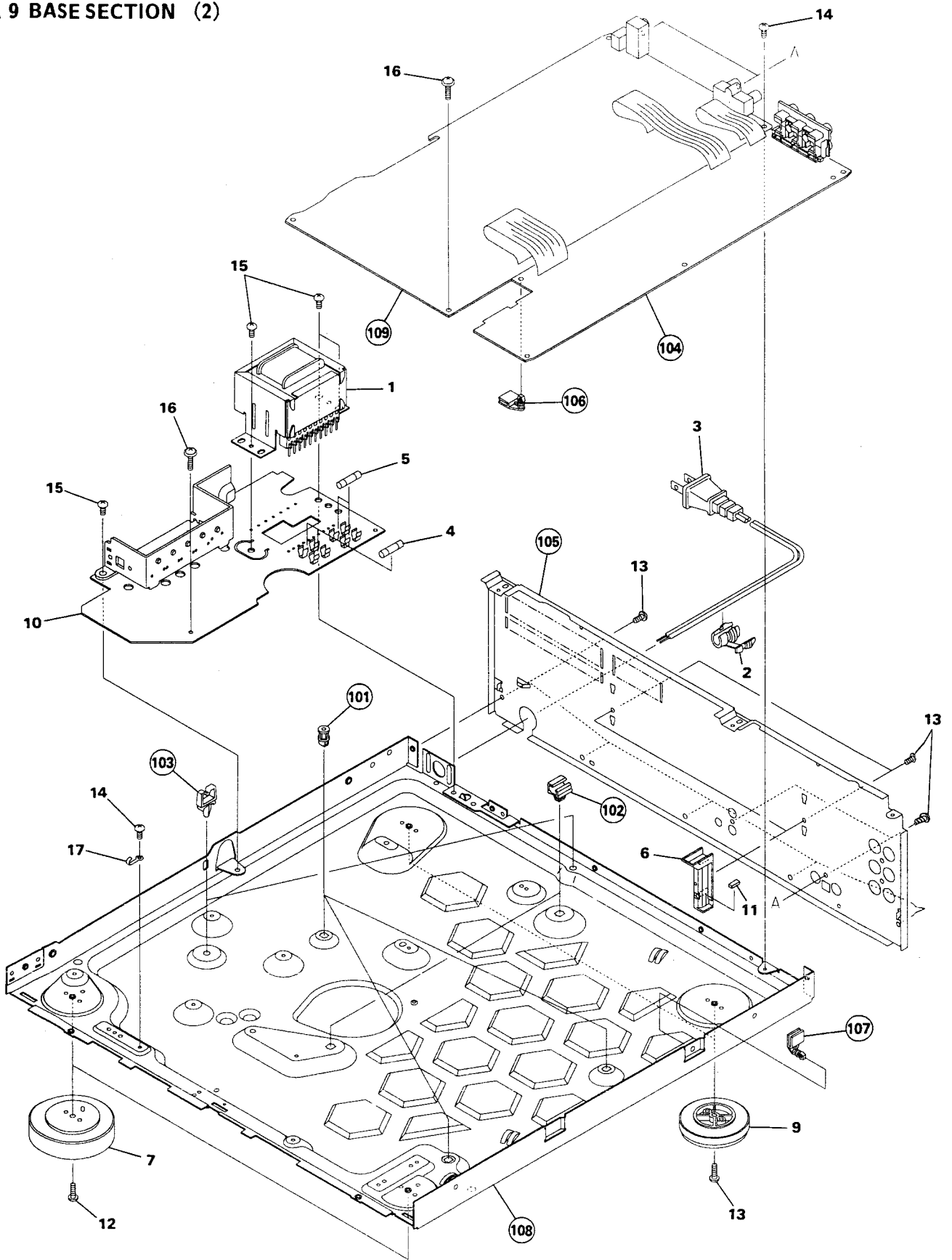

Parts List

Mark	No.	Description	Parts No.	Mark	No.	Description	Parts No.
	1.	Power transformer	VTT1096		101	PCB spacer	
	2.	AC cord stopper	CM-22C		102	P board holder	
	3.	AC power cord	PDG1015		103	Wire clip (B)	
	4.	Fuse (1A)	REK-080		104	Audio board assembly	
	5.	Fuse (3A)	VEK-018		105	Rear panel	
	6.	Tray stopper	VNL1202		106	PCB holder	
	7.	Insulator assembly	VXA1776		107	PCB holder	
	8.			108	Base chassis	
	9.	Insulator assembly	VXA1775		109	MAIN board assembly	
	10.	SYPS assembly	VWR1108				
	11.	Door dump rubber	VEB1033				
	12.	Screw	BBZ30P140FCC				
	13.	Screw	BBZ30P080FCC				
	14.	Screw	BBZ30P060FCC				
	15.	Screw	BCZ40P080FZK				
	16.	Screw	IPZ30P160FMC				
	17.	Cord holder	VNF-069				

3. 10 MECHANISM ASSEMBLY (1)

Parts List

Mark	No.	Description	Parts No.
	1.	Plate spring	VBK1013
	2.	Thrust spring	VBH1073
	3.	Tilt shaft	VLL1175
	4.	Tilt pulling spring	VBH1074
	5.	Belt	PEB1013
	6.	Screw	ABZ26P050FMC
	101	Cam head stopper	

A

A

B

B

C

C

D

D

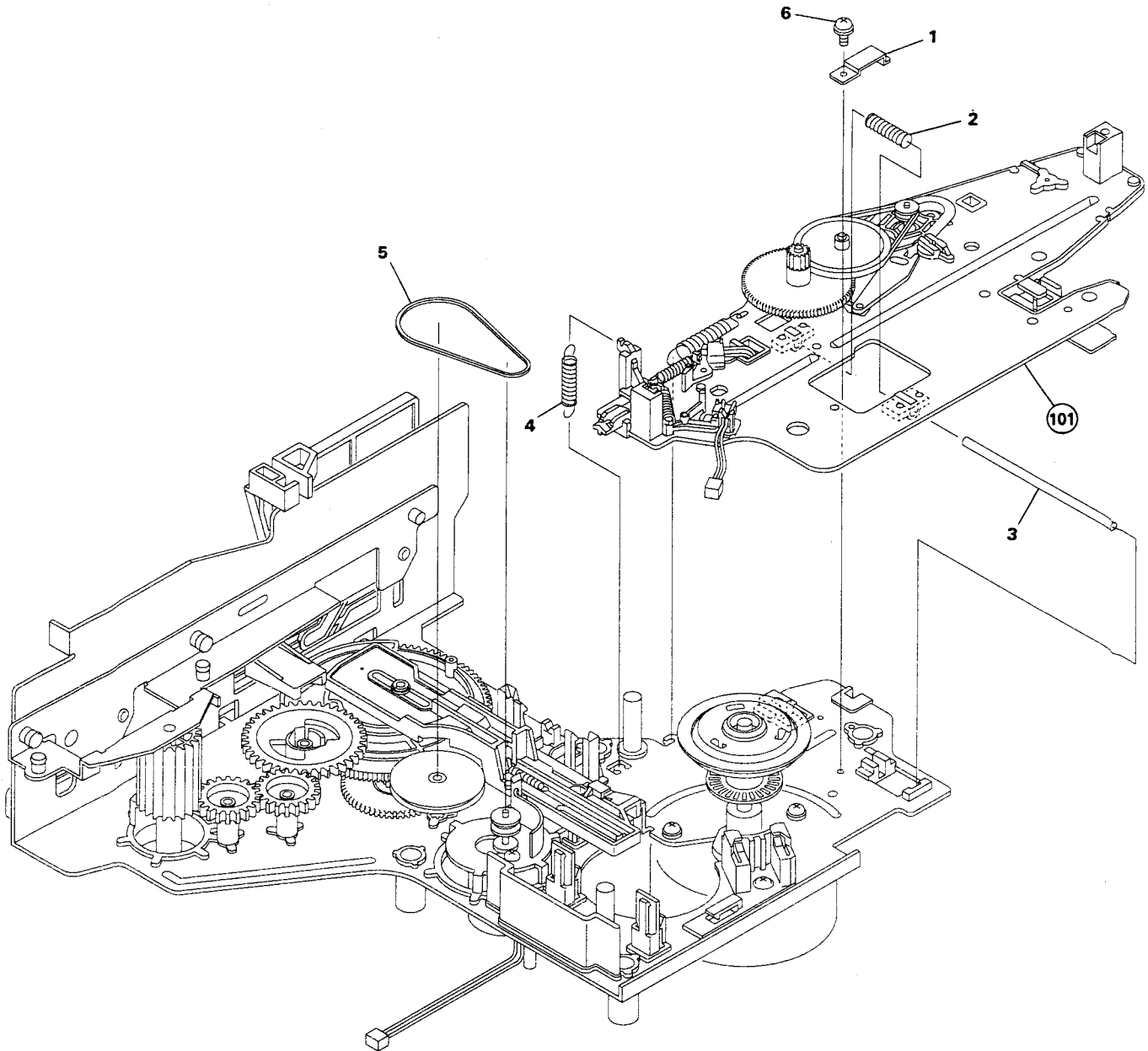

3. 11 CHASSIS SECTION

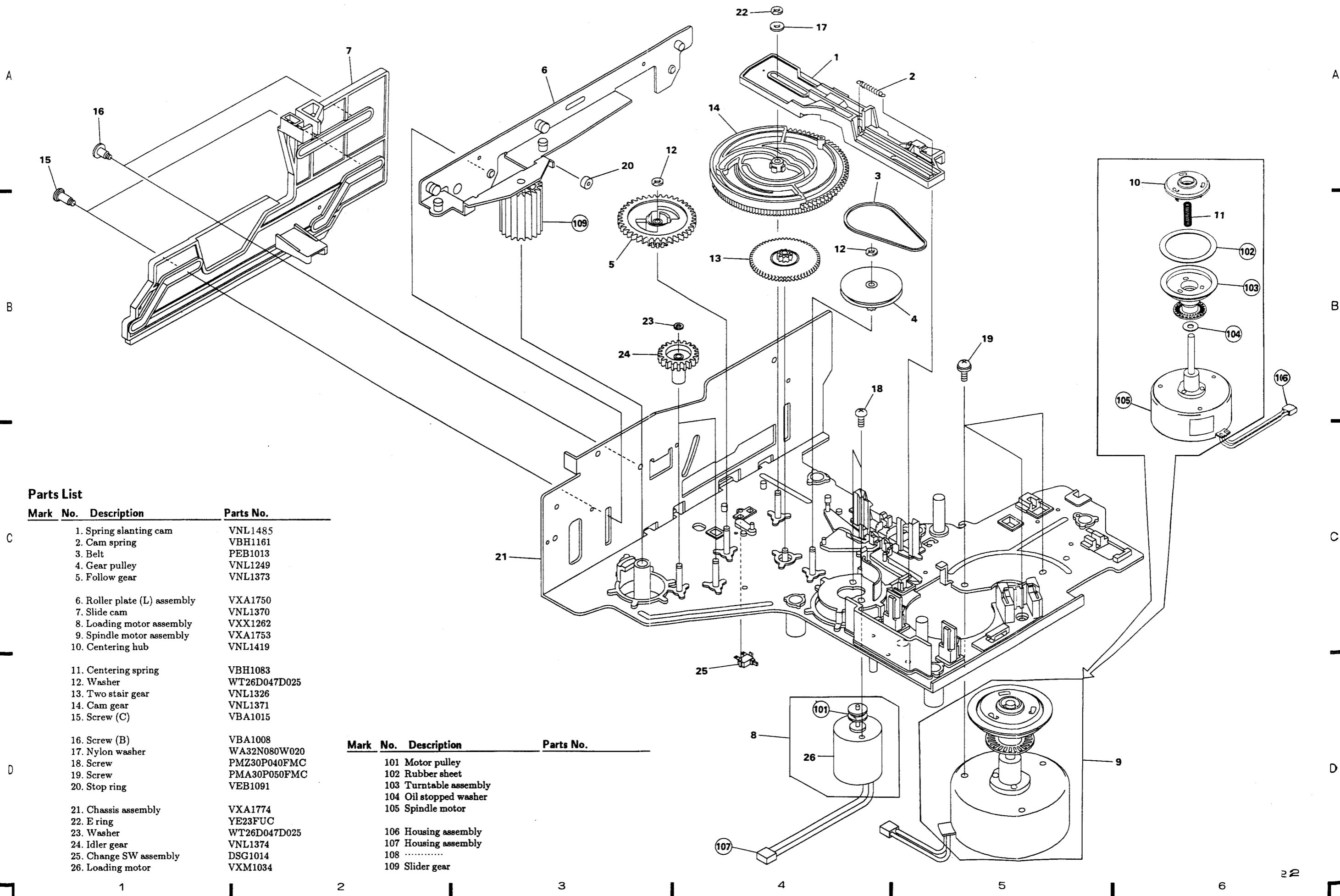

Parts List

Mark No.	Description	Parts No.
1.	Spring slanting cam	VNL1485
2.	Cam spring	VBH1161
3.	Belt	PEB1013
4.	Gear pulley	VNL1249
5.	Follow gear	VNL1373
6.	Roller plate (L) assembly	VXA1750
7.	Slide cam	VNL1370
8.	Loading motor assembly	VXX1262
9.	Spindle motor assembly	VXA1753
10.	Centering hub	VNL1419
11.	Centering spring	VBH1083
12.	Washer	WT26D047D025
13.	Two stair gear	VNL1326
14.	Cam gear	VNL1371
15.	Screw (C)	VBA1015
16.	Screw (B)	VBA1008
17.	Nylon washer	WA32N080W020
18.	Screw	PMZ30P040FMC
19.	Screw	PMA30P050FMC
20.	Stop ring	VEB1091
21.	Chassis assembly	VXA1774
22.	E ring	YE23FUC
23.	Washer	WT26D047D025
24.	Idler gear	VNL1374
25.	Change SW assembly	DSG1014
26.	Loading motor	VXM1034

Mark No.	Description	Parts No.
101	Motor pulley	
102	Rubber sheet	
103	Turntable assembly	
104	Oil stopped washer	
105	Spindle motor	
106	Housing assembly	
107	Housing assembly	
108	
109	Slider gear	

3. 12 SERVO MECHANISM BASE SECTION

Parts List

Mark No.	Description	Parts No.	Mark No.	Description	Parts No.
1	CA gear (3)	VNL1196	13	Washer	WT26D047D025
2	Switch pulling spring	VBH1079	14	FLE base	VNL1341
3	TC pulling spring	VBH1181	15	Servo mechanism base assembly-S	VXA1583
4	Push switch(S5 : CD/CDV)	DSG1014	16	Screw	PMZ26P040FMC
5	CA pulley(1)	VNL1197	101	Carriage motor	
6	Carriage motor assembly	VXX1261	102	Housing assembly	
7	Push switch(S4 : LD/CD)	DSG1014	103	Housing assembly	
8	CA belt	VEB1077	104	Housing assembly	
9	CA pulley (2)	VNL1198	105	Holder(A)	
10	Screw	SMF30H080FBT	106	Holder(B)	
11	Screw	PMM26P040FMC			
12	Screw	BPZ26P050FMC			

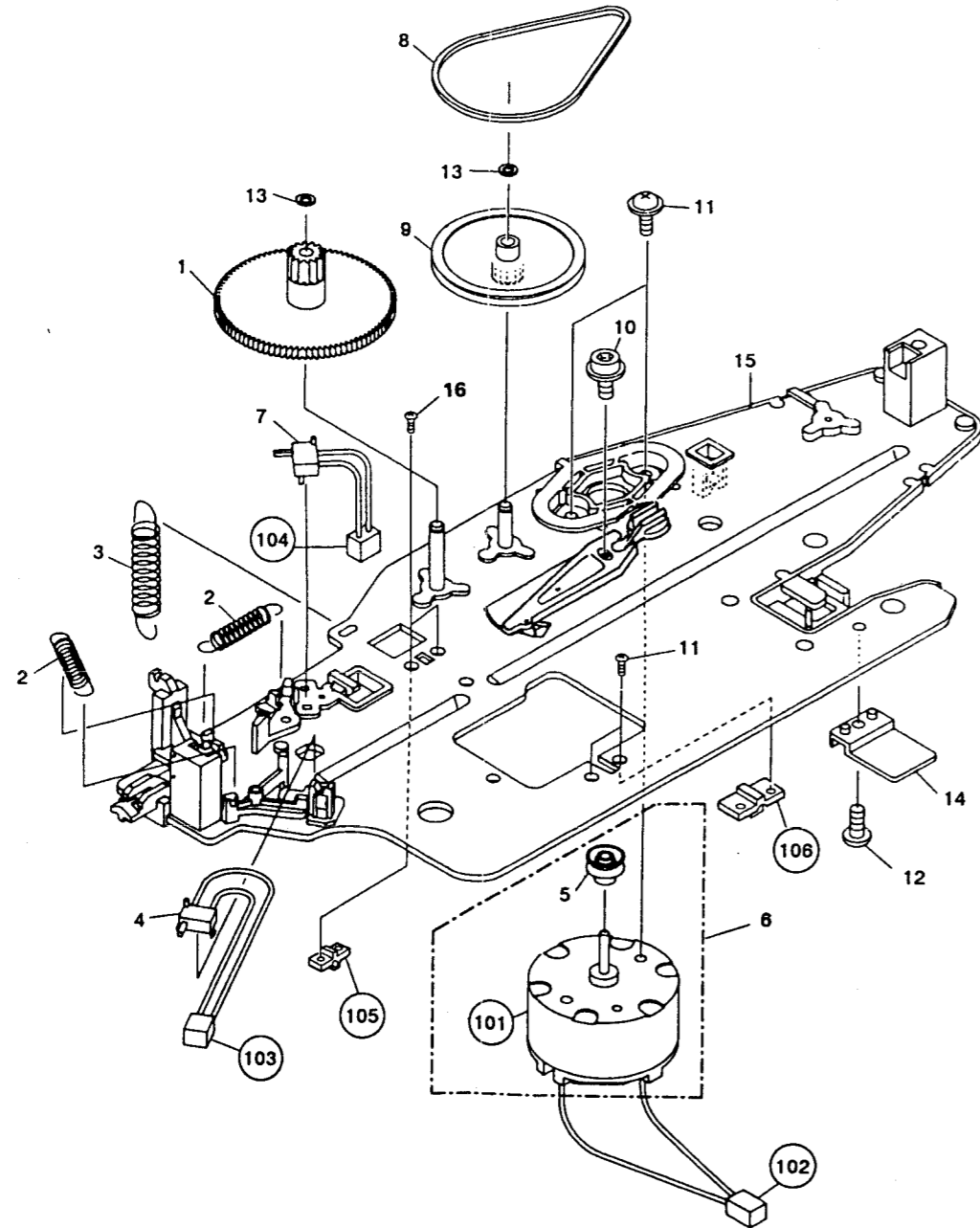

3. 13 RACK SECTION

Parts List

Mark No.	Description	Parts No.	Mark No.	Description	Parts No.
1	PU base	VNL1209	11	TAN base	VNL1199
2	LP center spring	VBH1075	12	Screw	PMZ20P040FMC
3	PU pulling spring	VBH1089	13	Screw	PMA20P040FMC
4	L-2 sprint	VBH1090	14	Screw	AMZ20P050FMC
5	Washer	WC30FMC	15	Slider assembly	VWT1060
6	Screw	VBA1007	16	PU mount base assembly	VXA1567
7	Screw(2.6 × 10)	VLL1192	17	Spacer (S)	VEC1284
8	Rack	VNL1186	18	TAN plate (1)	VNE1606
9	Screw	BMZ26P080FMC	101	TAN plate (2)	
10	TAN spring	VBH1081	102	Pickup assembly	

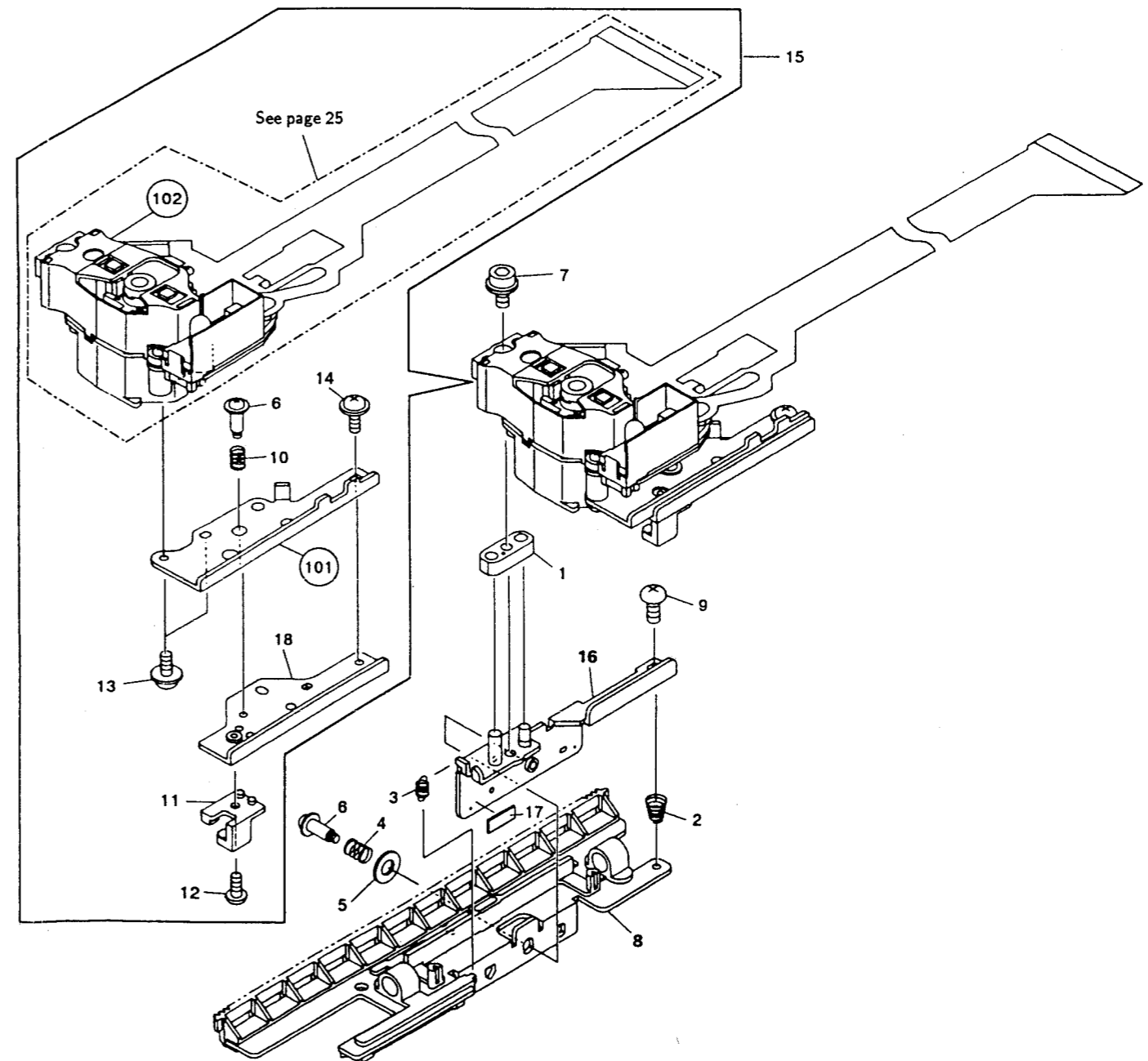

3.14 PICKUP ASSEMBLY

Parts List

Mark	No.	Description	Parts No.
	1.	Actuator assembly	VXX1551
	2.	Sensor assembly	VEX1018
	3.	Pre-pickup assembly	VXX1413
	4.	Sensor stay	VNH1024
	5.	Screw	PMA20P060FMC
	6.	Screw	PMA20P080FMC
	7.	Screw	PMA20P140FMC
	8.	Screw	BMZ20P060FMC
	9.	Sensor spring	VBH1087

A

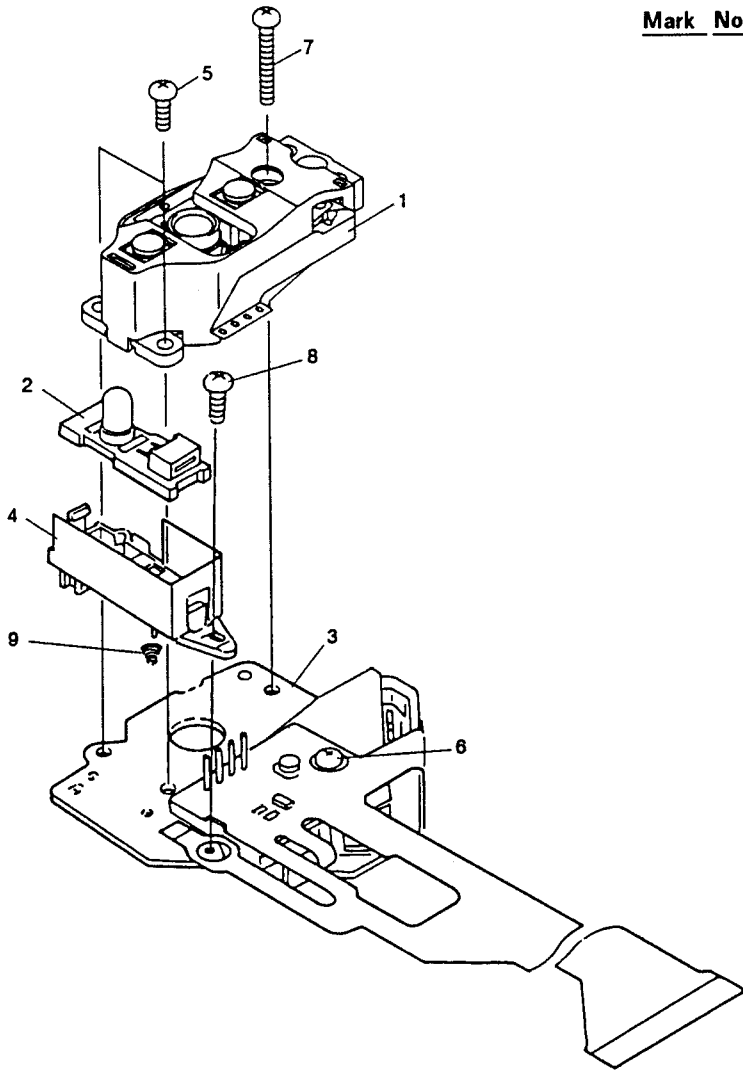

B

C

D

A

B

C

D

4. P.C. BOARDS LOCATION

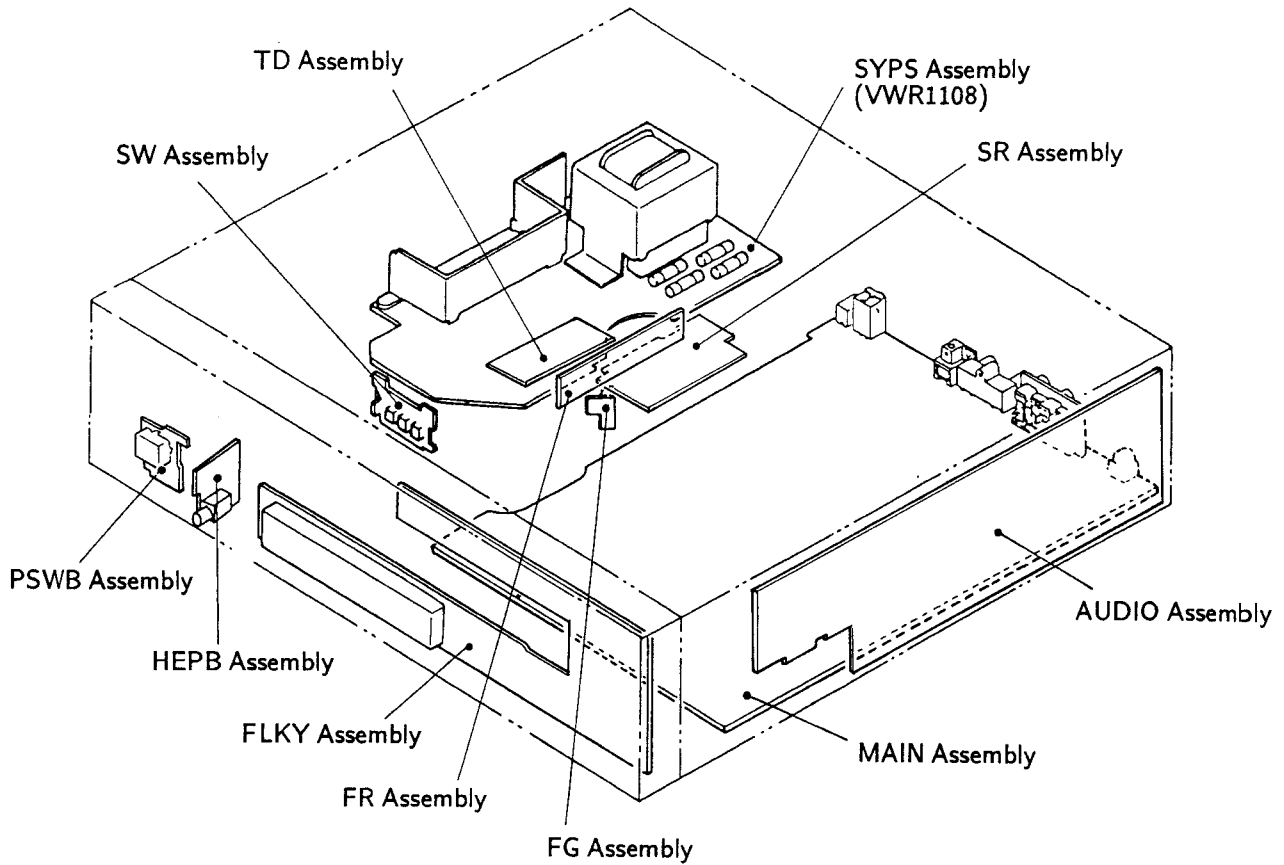

MOTHER ASSEMBLY(VWM1198)

MOTHER assembly is composed of MAIN, FG, SW and AUDIO assemblies.

FLKB ASSEMBLY (VWM1199)

FLKB assembly is composed of FLKY, PSWB and HEPB assemblies.

MSWB ASSEMBLY

MSWB assembly is composed of SR, FR, CF, CS, and TD assemblies.

MAIN	: MAIN BOARD
FG	: FG COUNTER BOARD
SW	: SW BOARD
AUDIO	: AUDIO BOARD
FLKY	: FL TUBE AND KEY BOARD
PSWB	: POWER SWITCH BOARD
HEPB	: HEADPHONE BOARD
SYPS	: SYSTEM POWER SUPPLY
SR	: SOLID RELAY BOARD
FR	: FLEXIBLE RELAY BOARD
CF	: CARRIAGE FLEXIBLE BOARD
CS	: CARRIAGE SWITCH BOARD
TD	: TURN DETECTION BOARD

5.2 SYPS ASSEMBLY(VWR 1108)

A

B

C

D

- Q201, Q204, D101, 103 MTZJ5.6B
 - Q206: 2SD1762 D102, 104 MTZJ5.1C
 - Q202, Q203, D201, D202: S2VB20
 - Q205: 2SB1185 D208, D209,
 - Q207: 2SB1238X D216, D217: 1SS252
 - Q214, Q219: 2SA933S D213, D214,
 - Q213: DTC114ES D222, D223: 1SR35-100AVL
 - Q218: 2SC1740S D212, D215: 10ELS2
 - Q217: DTA114ES D220: MTZJ27A
- IC201-202: ICP-N15 R221: RS1LMFR51J
 - IC206: ICP-N25 R239: RS1LMF4R7J
 - IC205: NJM78M05FA R231: VCN1029
- L201: VTL100B
 - L202: VTL-157
- C205, C206: VCH1095
 - C216, C217: RCG-009

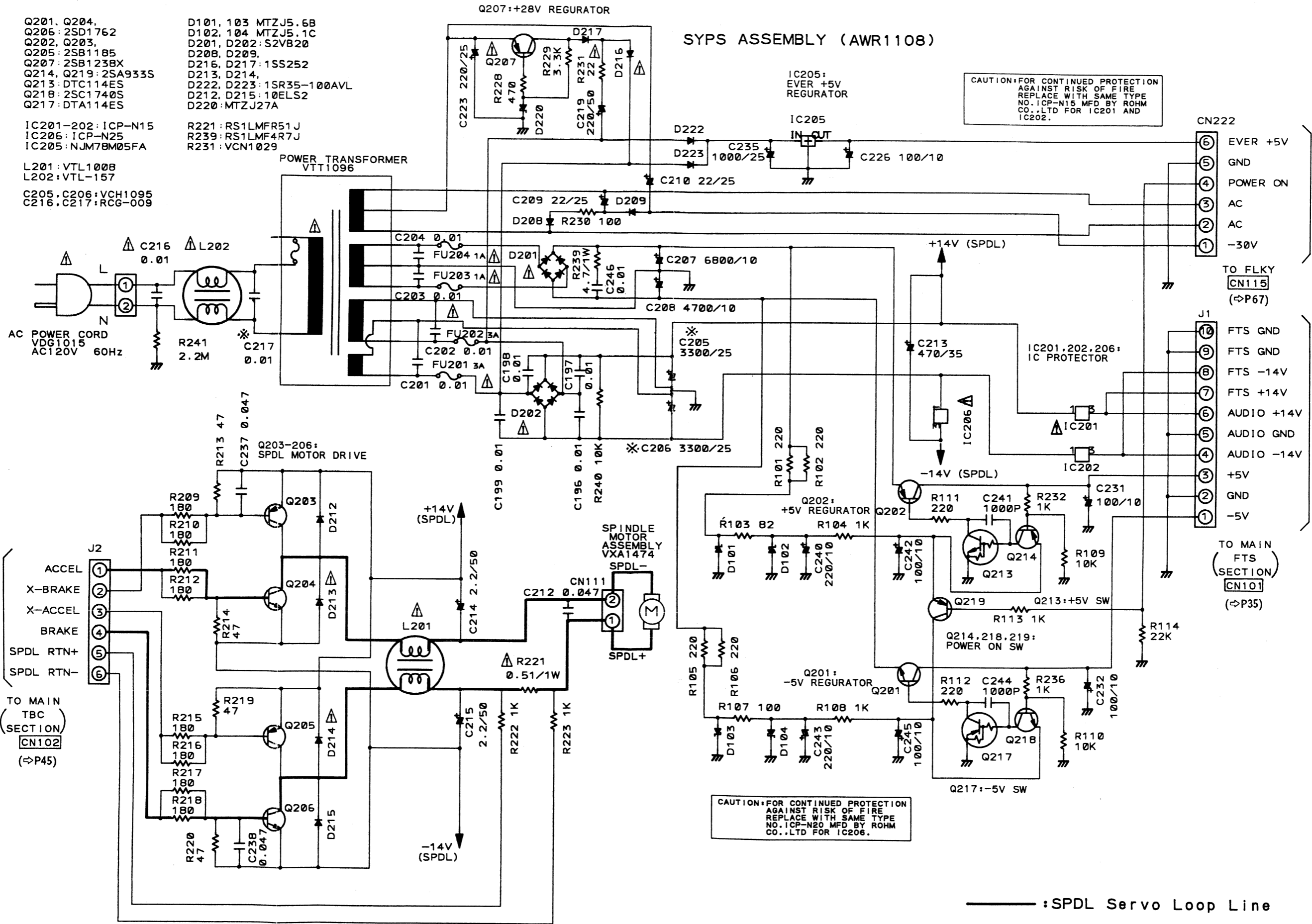

CAUTION: FOR CONTINUED PROTECTION AGAINST RISK OF FIRE REPLACE WITH SAME TYPE NO. ICP-N15 MFD BY ROHM CO., LTD FOR IC201 AND IC202.

CAUTION: FOR CONTINUED PROTECTION AGAINST RISK OF FIRE REPLACE WITH SAME TYPE NO. ICP-N20 MFD BY ROHM CO., LTD FOR IC206.

:SPDL Servo Loop Line

This P.C.B. connection diagram is viewed from the parts mounted side.

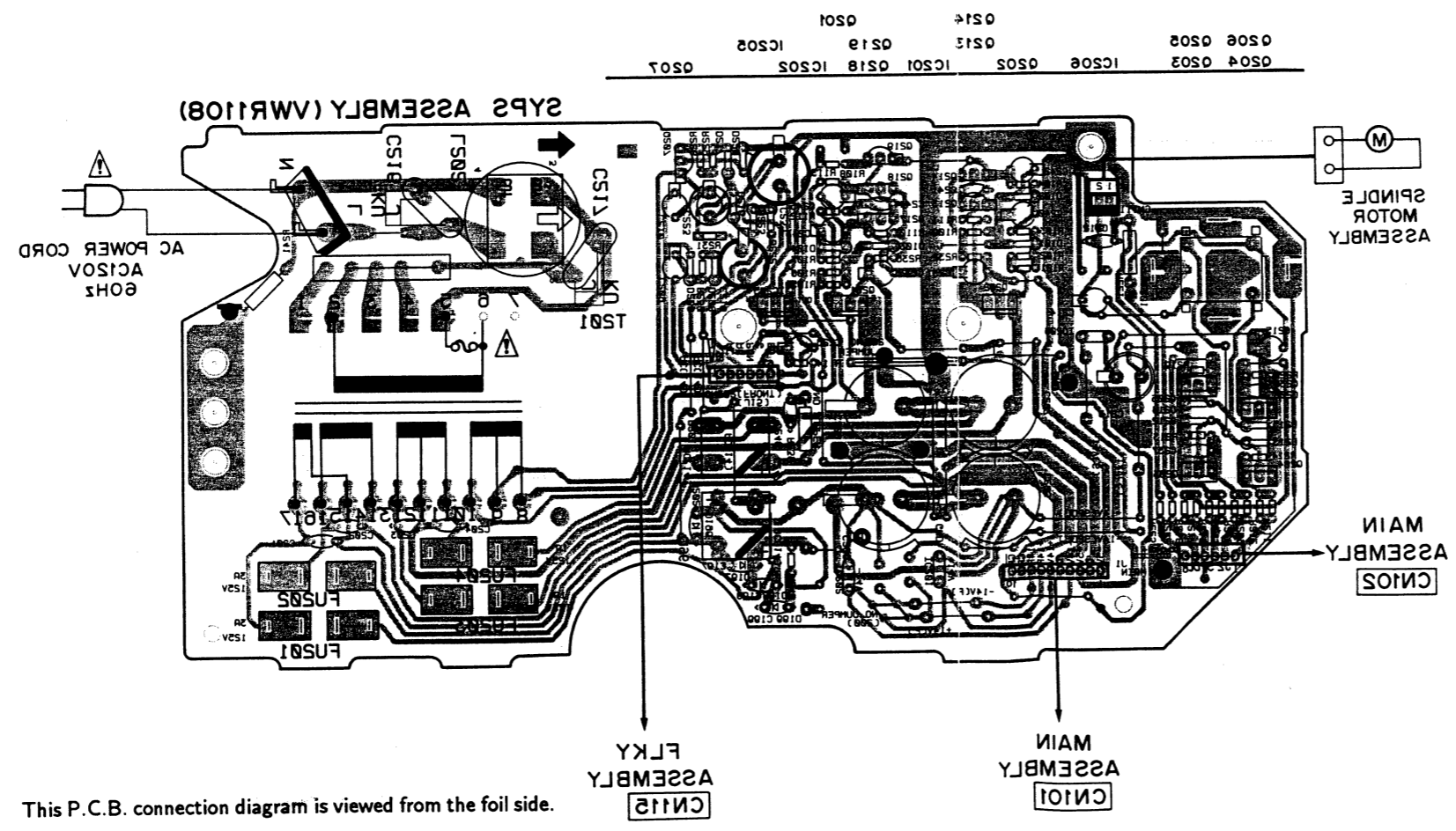
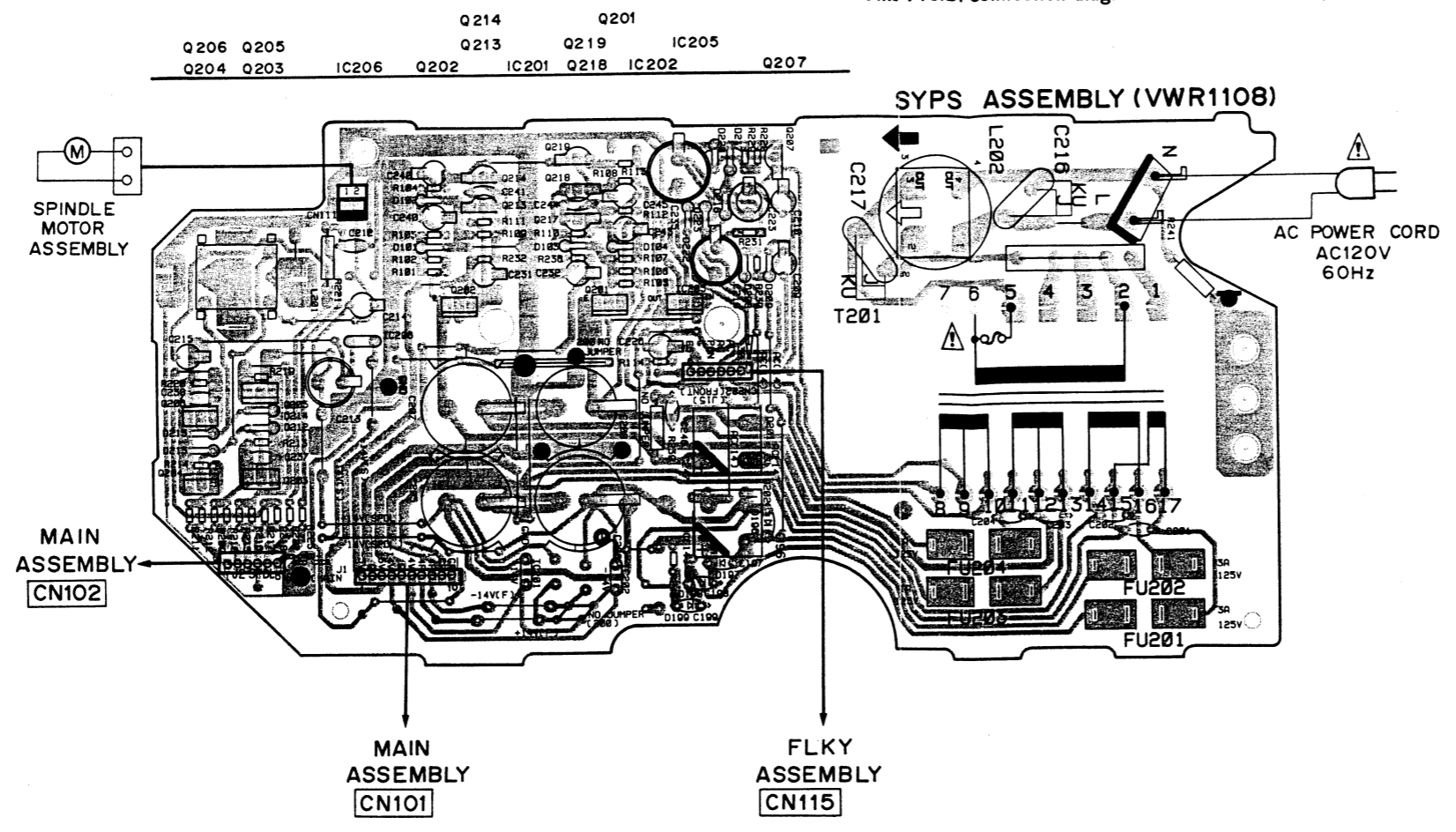

This P.C.B. connection diagram is viewed from the foil side.

P.C.B. pattern diagram indication	Corresponding part symbol	Part name
		Transistor
		FET
		Diode
		Zener diode
		LED
		Varactor
		Tact switch
		Inductor
		Coil
		Transformer
		Filter
		Ceramic capacitor
		Mylar capacitor
		Styrol capacitor
		Electrolytic capacitor (Non polarized)
		Electrolytic capacitor (Noiseless)
		Electrolytic capacitor (Polarized)
		Electrolytic capacitor (Polarized)
		Power capacitor
		Semi-fixed reactor
		Resistor array
		Resistor
		Resonator
		Thermistor

1. This P.C.B. connection diagram is viewed from the parts mounted side.
2. The parts which have been mounted on the board can be replaced with those shown with the corresponding wiring symbols listed in the above table.
3. The capacitor terminal marked with shows negative terminal.
4. The diode marked with shows cathode side.
5. The transistor terminal marked with shows emitter.

5.3 PICKUP ASSEMBLY

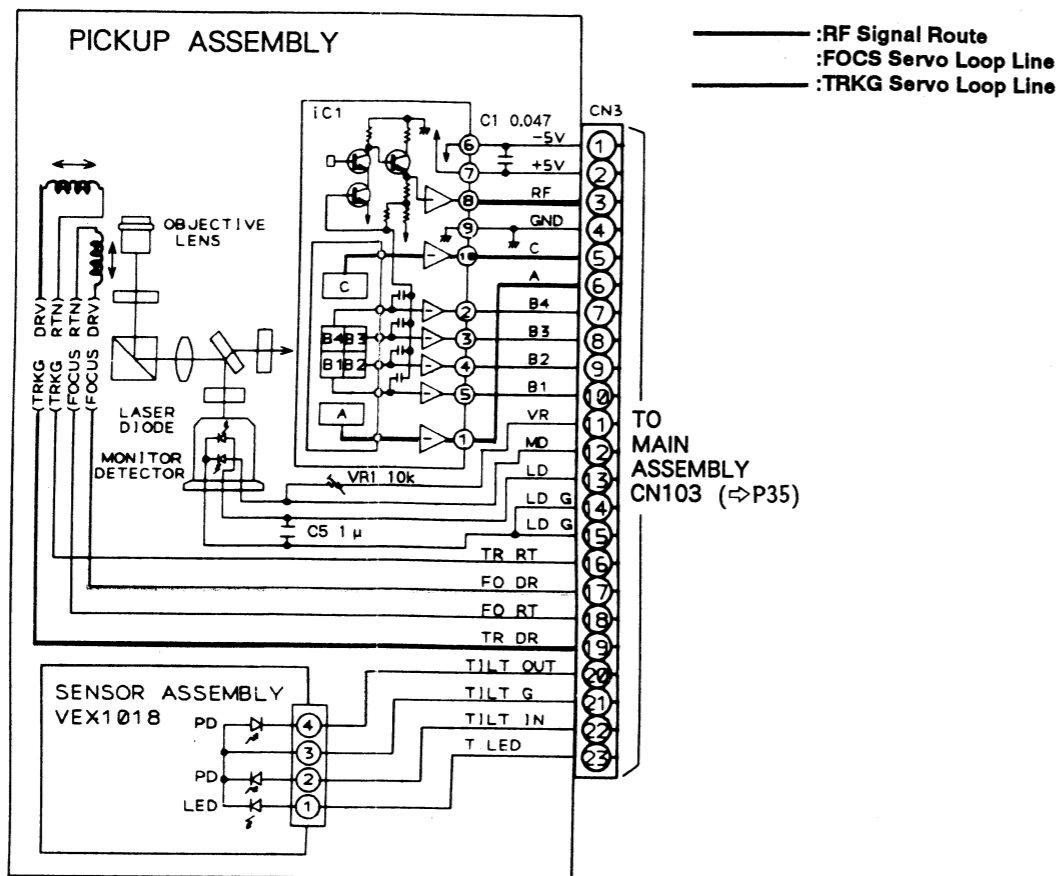

HEAD ASSEMBLY

This P.C.B. connection diagram is viewed from the parts mounted side.

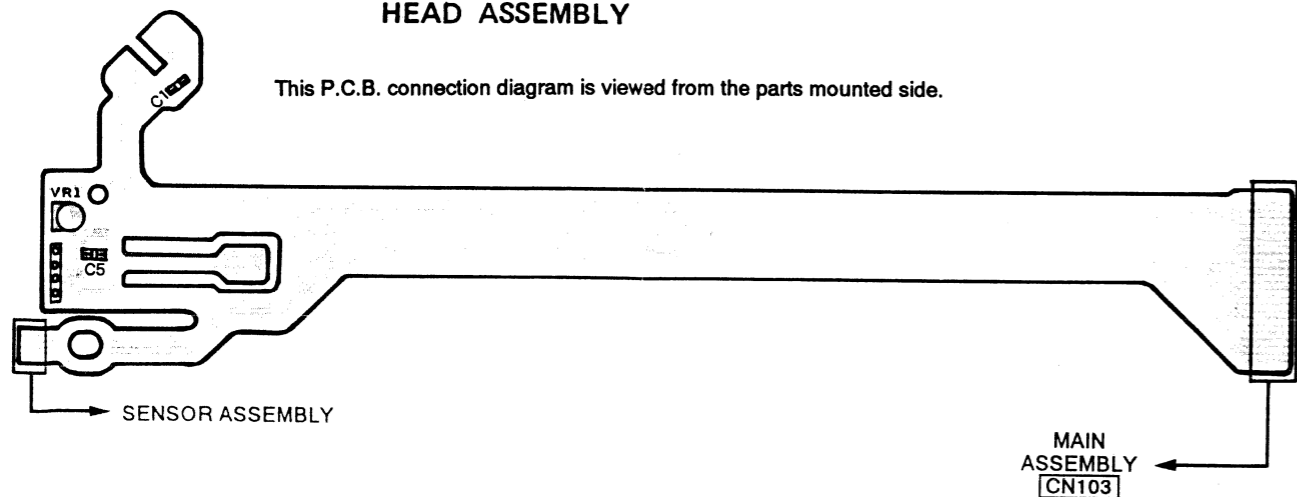

This P.C.B. connection diagram is viewed from the foil side.

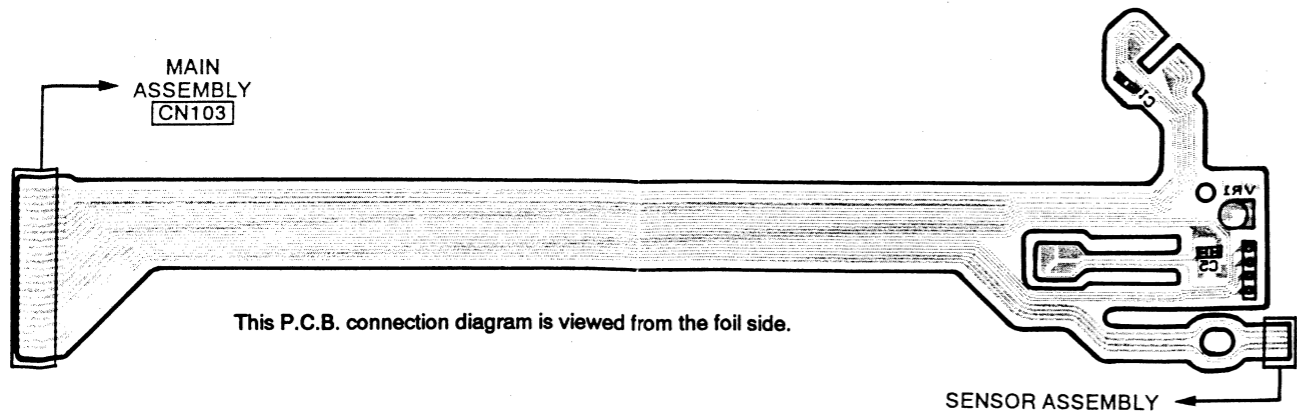

FTS SECTION

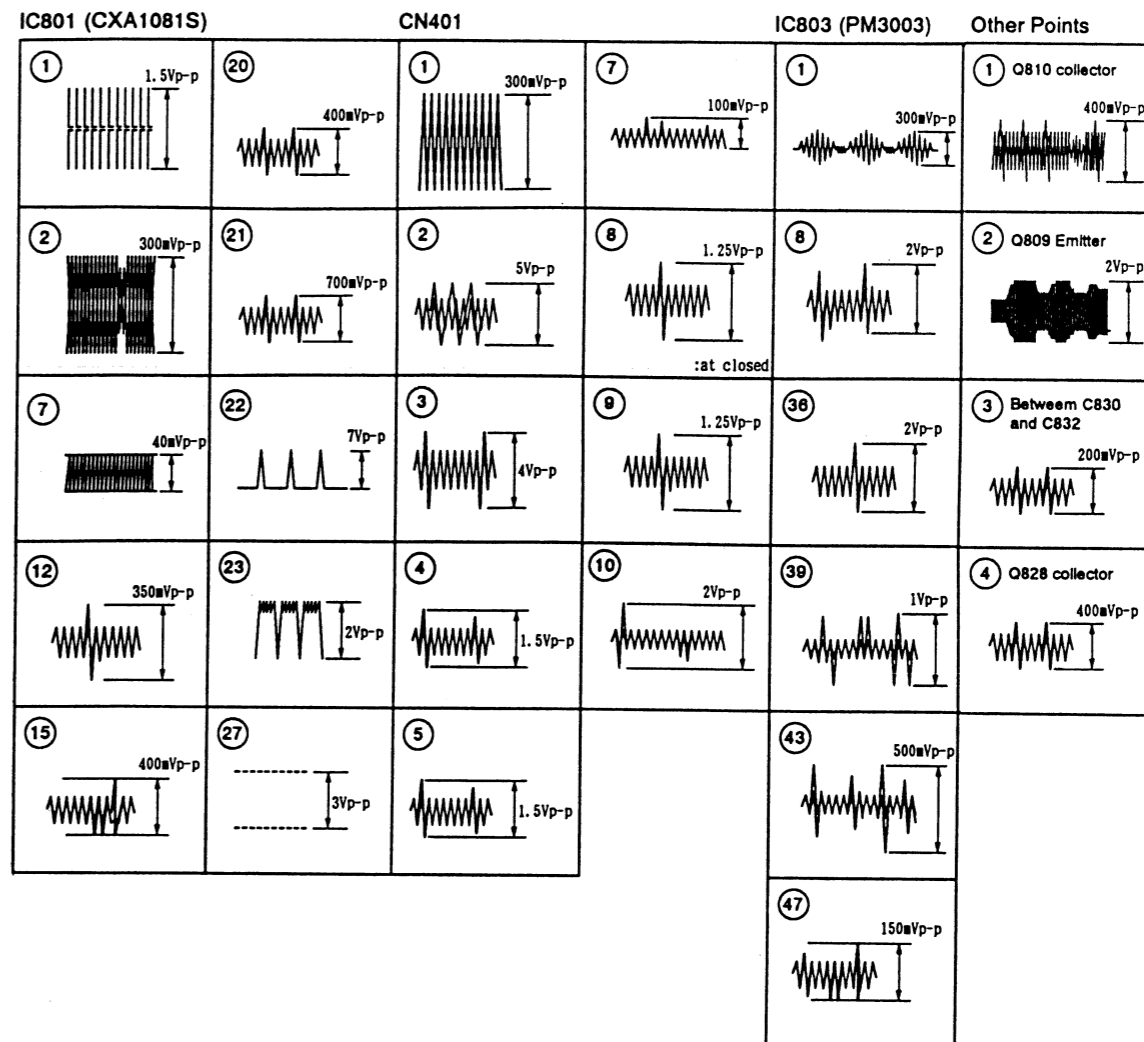

- RESISTORS:**
Indicated in Ω, 1/4W, 1/6W and 1/8W, ±5% tolerance unless otherwise noted k;k Ω, M;M Ω, (F); ± 1%, (G); ± 2%,(K); ± 10%, (M); ± 20% tolerance.
- CAPACITORS:**
Indicated in capacity (μF) /voltage(V)unless otherwise noted p;pF. Indication without voltage is 50V except electrolytic capacitor.
- VOLTAGE, CURRENT:**
 - :DC voltage (V) at no input signal.
 - Value in () is DC voltage at rated power.
 - ⇐ mA :DC current at no input signal.
- OTHERS:**
 - :Signal route.
 - ⊙ :Adjusting point.

The Δ mark found on some component parts indicates the importance of the safety factor of the part. Therefore, when replacing, be sure to use parts of identical designation.

* marked capacitors and resistors have parts numbers.

This is the basic schematic diagram, but the actual circuit may vary due to improvements in design.

5.4 MAIN ASSEMBLY(FTS Section)

MAIN ASSEMBLY(FTS SECTION)

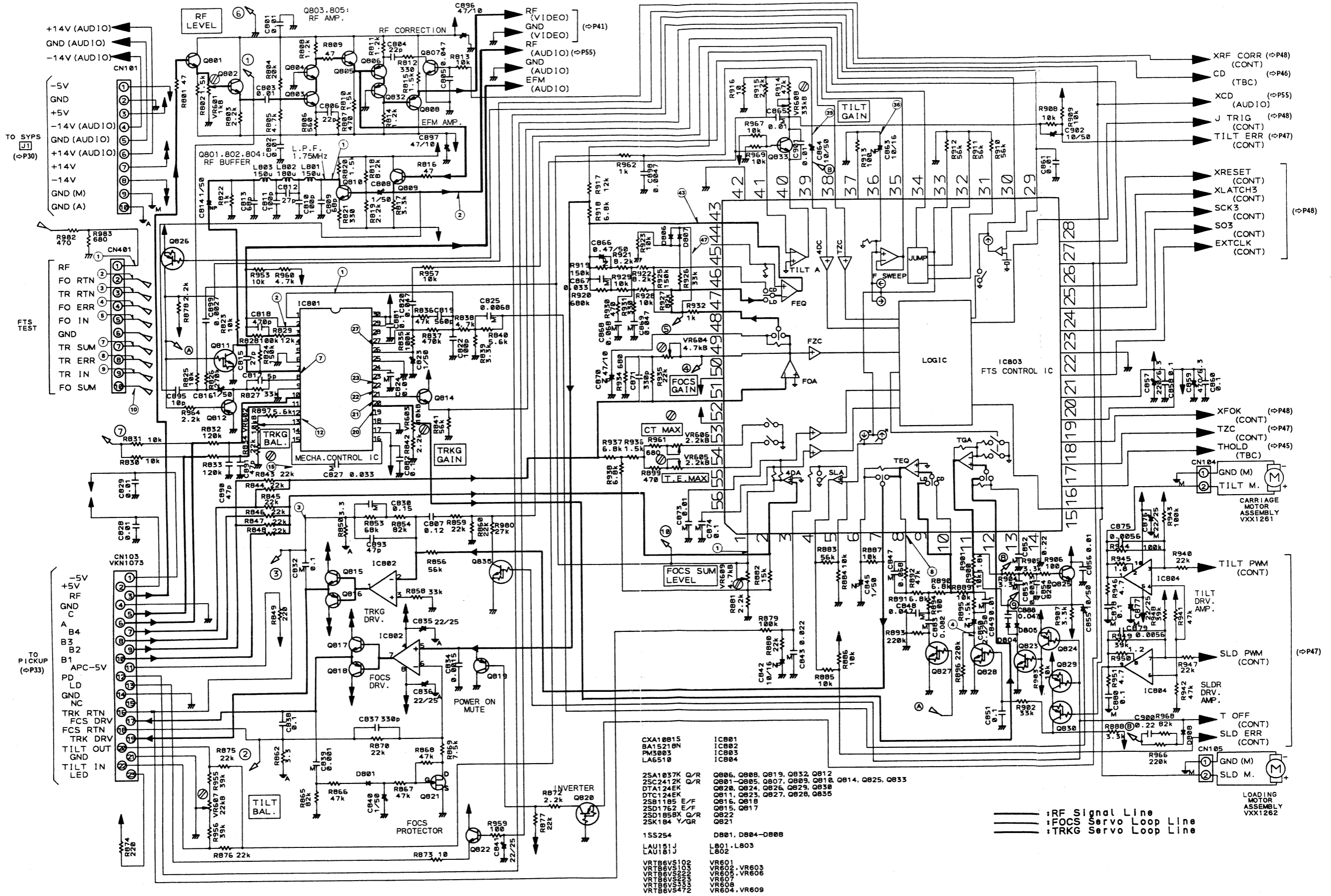

CARRIAGE MOTO ASSEM

LOADIN MOTO ASSEMI

(→P47)

(→P47)

(→P47)

(→P47)

(→P47)

- | | | |
|--------------|---|---|
| CXA10015 | IC801 | Q806, Q808, Q819, Q832, Q812 |
| 8A15210N | IC802 | Q801-Q805, Q807, Q809, Q818, Q814, Q825, Q833 |
| PM3003 | IC803 | Q828, Q824, Q826, Q823, Q838 |
| LA6510 | IC804 | Q811, Q823, Q827, Q828, Q835 |
| 2SA1037K | Q806, Q808, Q819, Q832, Q812 | |
| 2SC2412K | Q801-Q805, Q807, Q809, Q818, Q814, Q825, Q833 | |
| DTA124EK | Q828, Q824, Q826, Q823, Q838 | |
| DTC124EK | Q811, Q823, Q827, Q828, Q835 | |
| 2SB1185 E/F | Q816, Q818 | |
| 2SD1762 E/F | Q815, Q817 | |
| 2SD1858X Q/R | Q822 | |
| 2SK104 Y/G/R | Q821 | |
| 1S5254 | DB01, DB04-DB08 | |
| LAU151J | L801, L803 | |
| LAU181J | L802 | |
| VRTB6V510 | VR601 | |
| VRTB6V510Q | VR602, VR603 | |
| VRTB6V510R | VR605, VR606 | |
| VRTB6V510S | VR607, VR608 | |
| VRTB6V510T | VR609 | |
| VRTB6V5472 | VR604, VR609 | |

RF Signal Line
 FOCUS Servo Loop Line
 TRKG Servo Loop Line

7

8

9

10

11

48)

47)

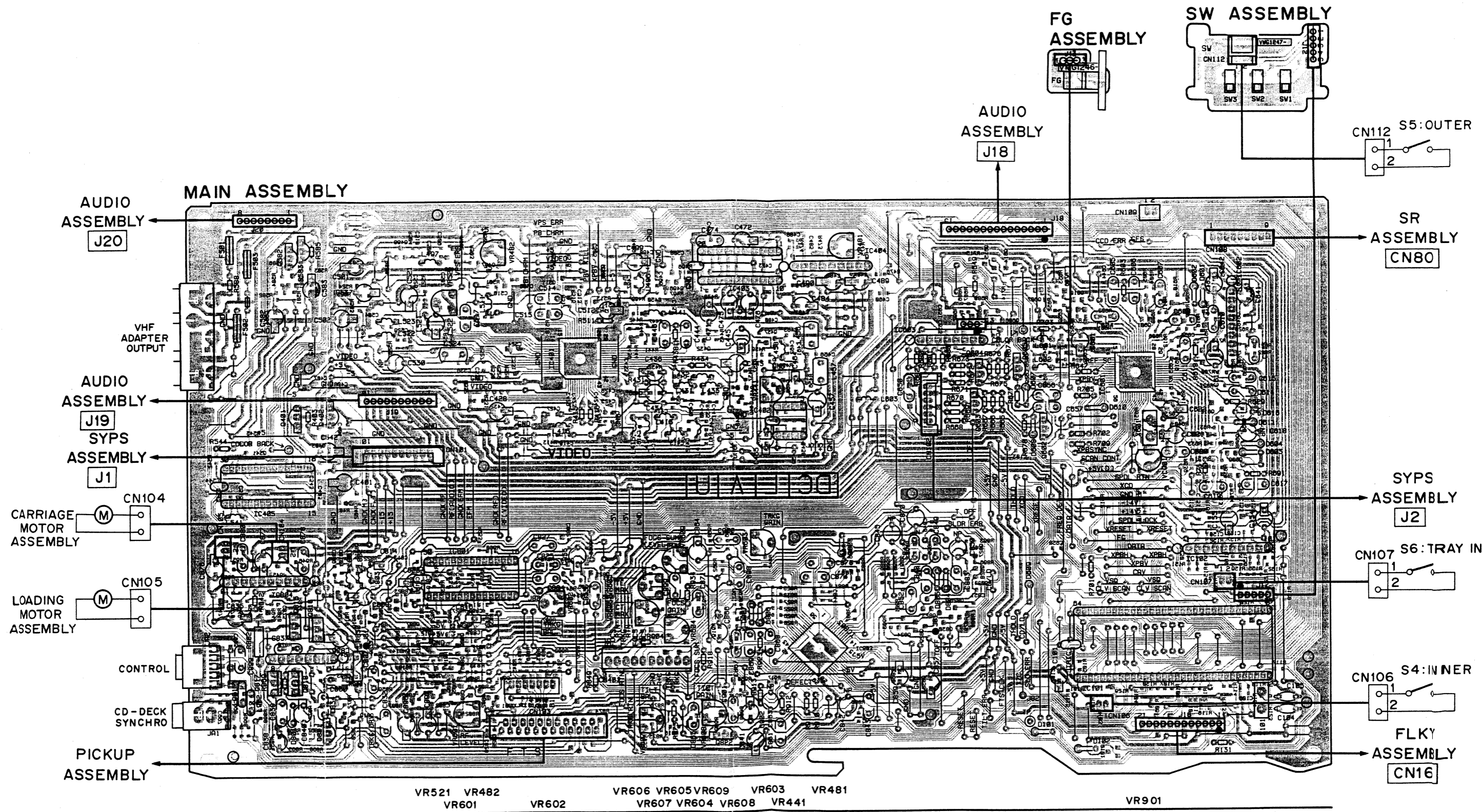

VR521 VR482		VR601 VR602		VR606 VR605 VR609 VR603 VR481				VR901							
				VR607 VR604 VR608 VR441											
IC405	IC802	Q821	Q840	IC801	IC401	Q820	Q822	IC402	IC404	IC603	Q820	Q120	IC601	IC101	IC602
IC804	Q582	Q583	Q580	Q180	Q580	Q580	Q580	IC403	IC803	Q580	Q580	Q580	Q101	Q800	Q102
Q820	Q401	Q402	Q800	Q820	Q820	Q820	Q820	Q820	Q820	Q820	Q820	Q820	Q820	Q820	Q820
Q820	Q815	Q818	Q180	Q180	Q180	Q180	Q180	Q180	Q180	Q180	Q180	Q180	Q180	Q180	Q180
Q820	Q820	Q820	Q820	Q820	Q820	Q820	Q820	Q820	Q820	Q820	Q820	Q820	Q820	Q820	Q820

7

8

9

10

11

12

This P.C.B. connection diagram is viewed from the foil side.

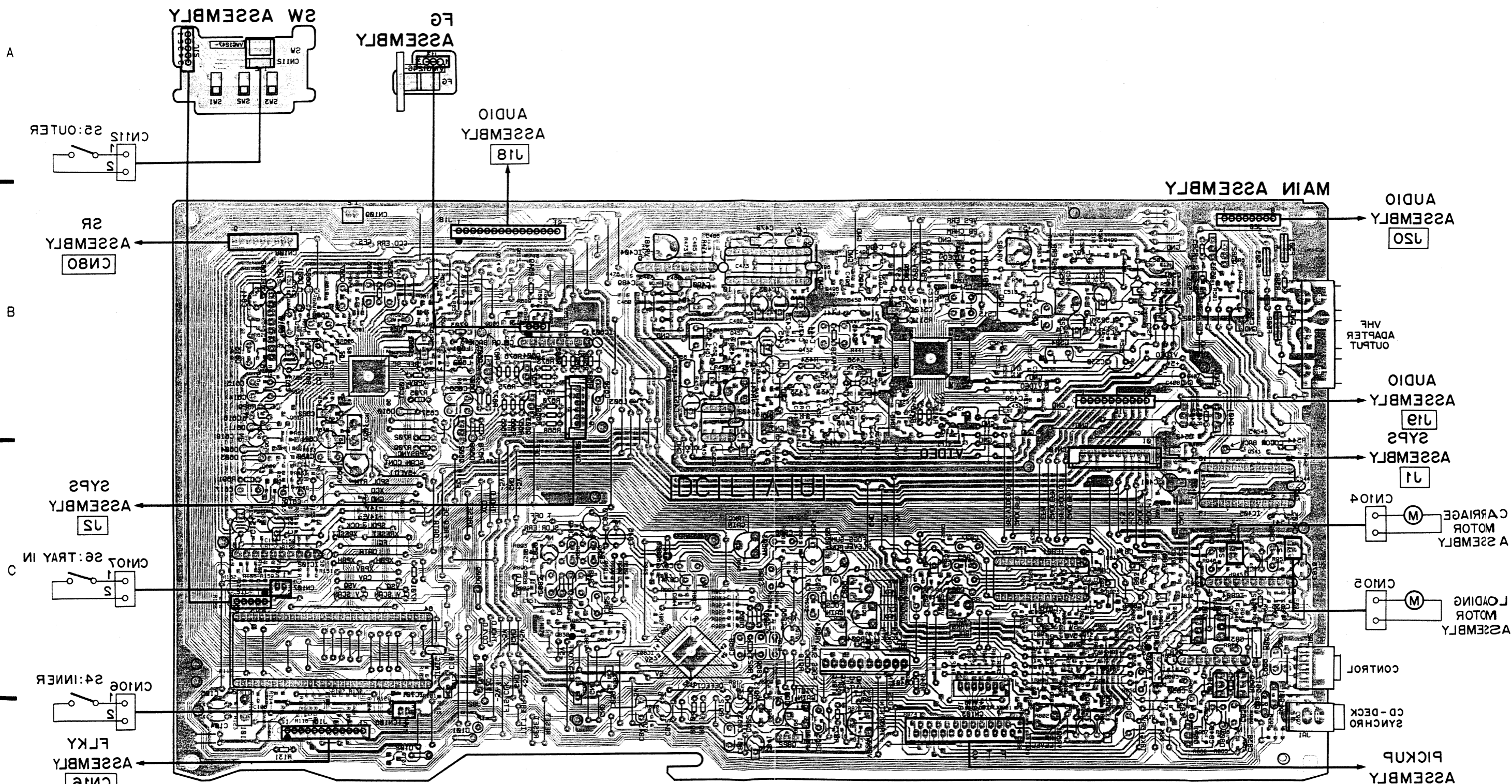

VR481	VR482	VR483	VR484	VR485	VR486	VR487	VR488	VR489	VR490	VR491	VR492	VR493	VR494	VR495	VR496	VR497	VR498	VR499	VR500
IC102	IC103	IC104	IC105	IC106	IC107	IC108	IC109	IC110	IC111	IC112	IC113	IC114	IC115	IC116	IC117	IC118	IC119	IC120	IC121
Q497	Q498	Q499	Q500	Q501	Q502	Q503	Q504	Q505	Q506	Q507	Q508	Q509	Q510	Q511	Q512	Q513	Q514	Q515	Q516
Q517	Q518	Q519	Q520	Q521	Q522	Q523	Q524	Q525	Q526	Q527	Q528	Q529	Q530	Q531	Q532	Q533	Q534	Q535	Q536

5.5 MAIN ASSEMBLY(VIDEO Section)

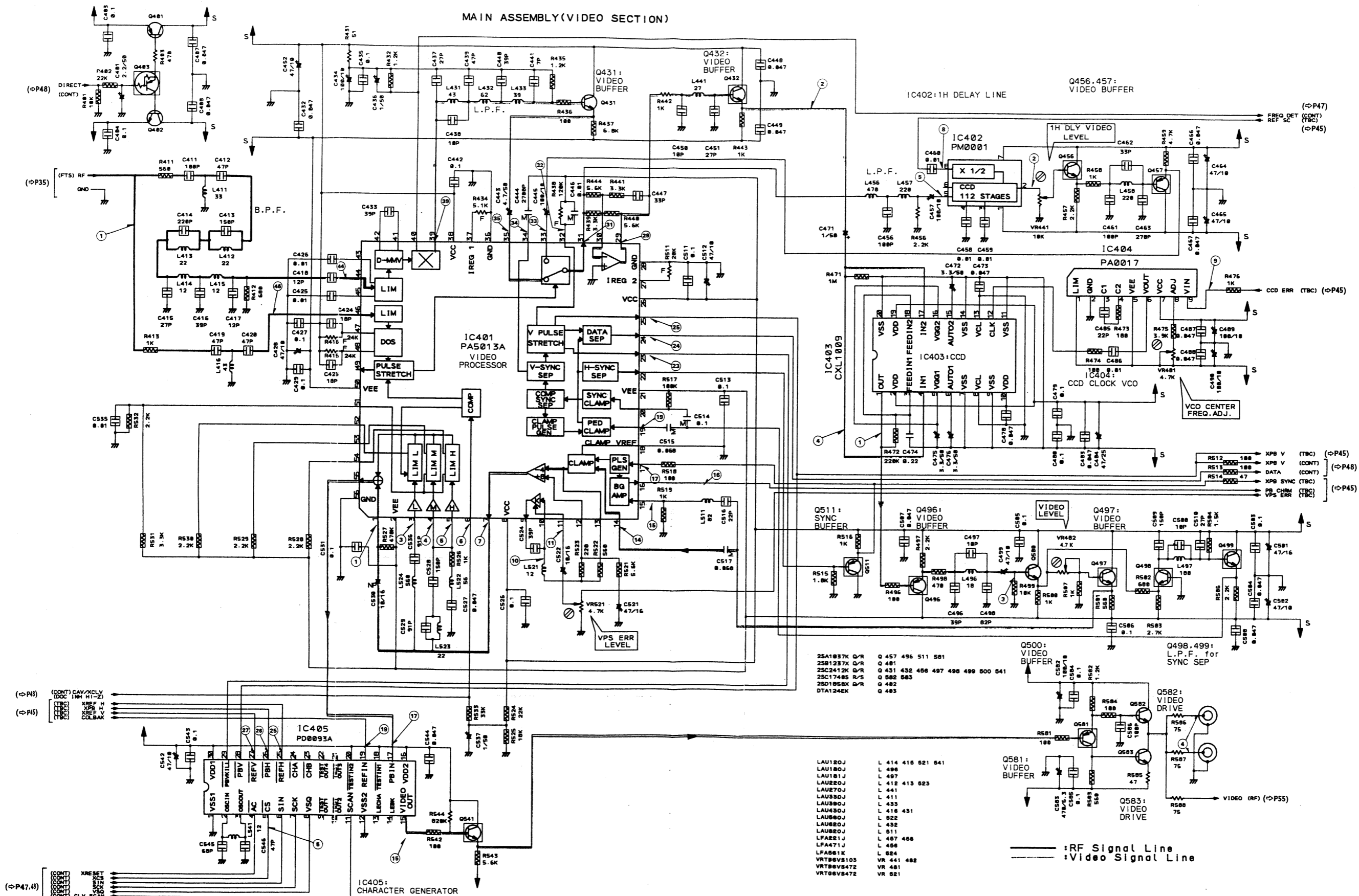

A

B

C

D

WAVEFORMS OF THE VIDEO SECTION

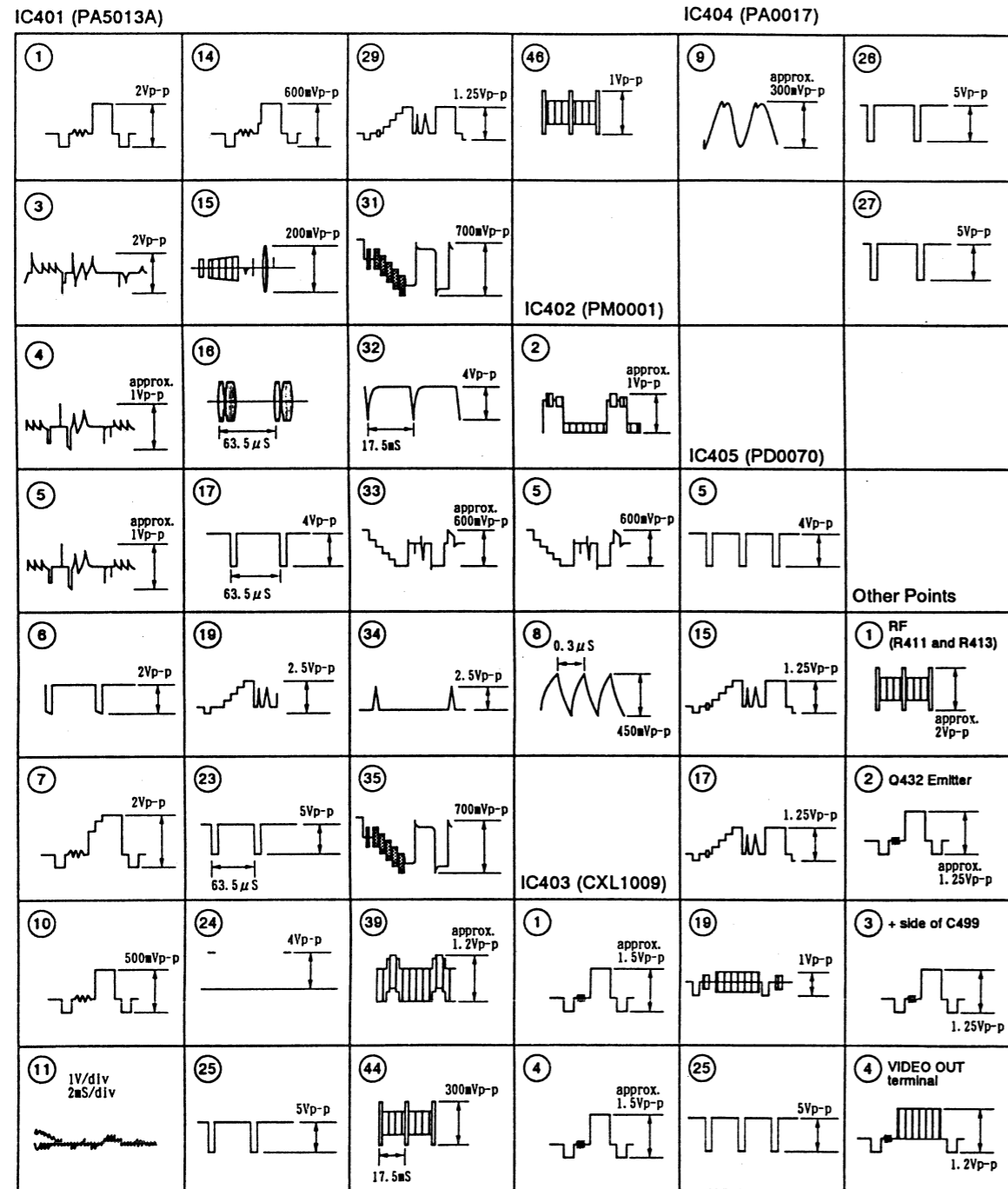

5.6 MAIN ASSEMBLY(TBC Section)

IC601: PM3002	2SC1740S	R/S: Q502, 604	LAU101J	!L601, 602
IC602: NJM4558S	2SA933S	R/S: Q503, 605	LAU470J	!L603
IC603: BA15219N	2SC2412K	Q/R: Q607, 610, 612, 614		
VC901: VCM-008	2SA1037K	Q/R: Q609, 615		
X601: VSS1026	DTC124EK	Q: Q506, 608		
	DTA124EK	Q: Q513		
	FMW2	Q: Q501		
	1SS254	D: D501-604, 607-611		

MAIN ASSEMBLY(TBC SECTION)

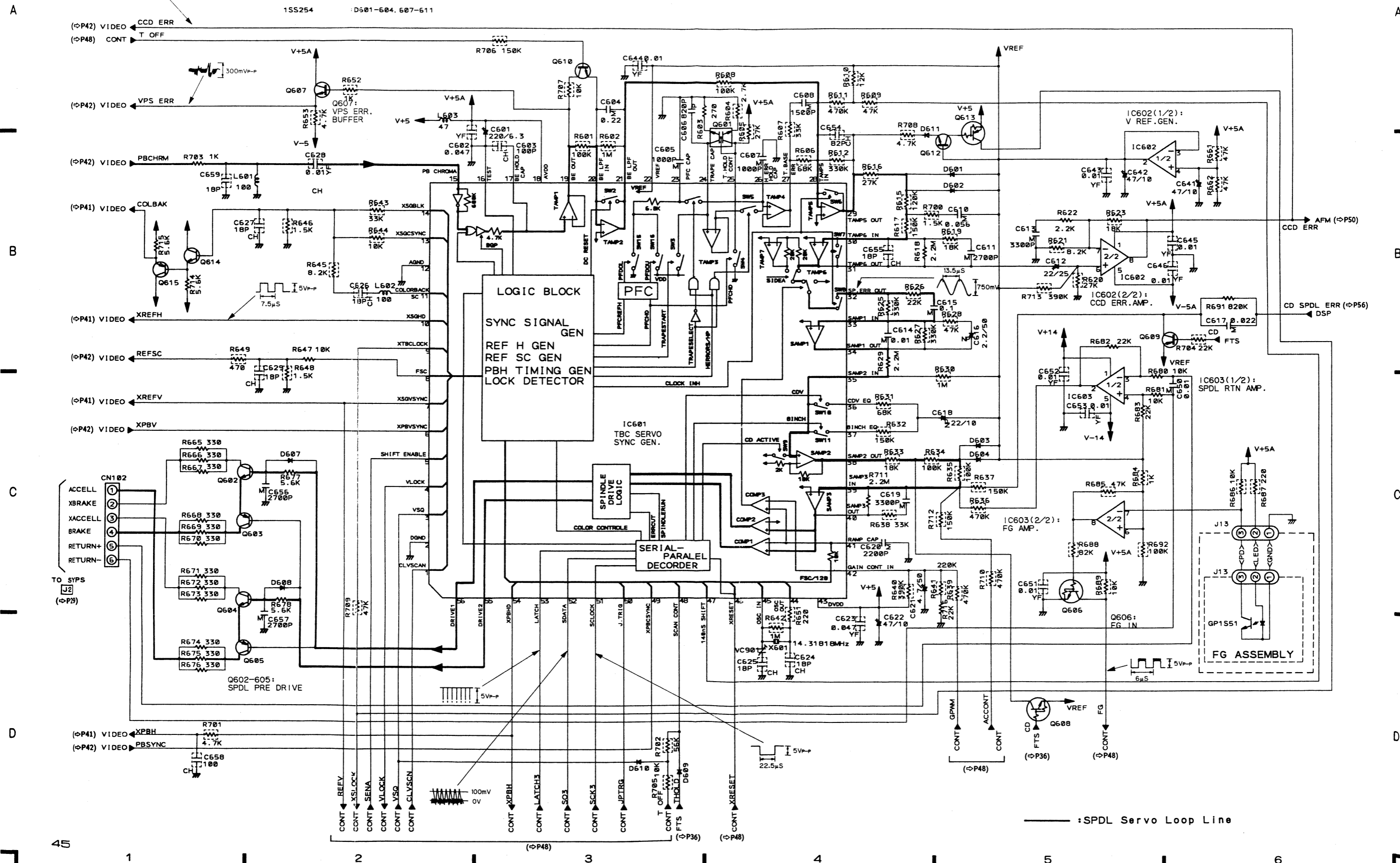

5.7 MAIN ASSEMBLY(CONT Section)

MAIN ASSEMBLY(CONT SECTION)

- D101-102 :1S5254
- Q101 :DTC124EK
- X101 :V5S1040
- IC101 :PD0104A
- IC102 :LA6510

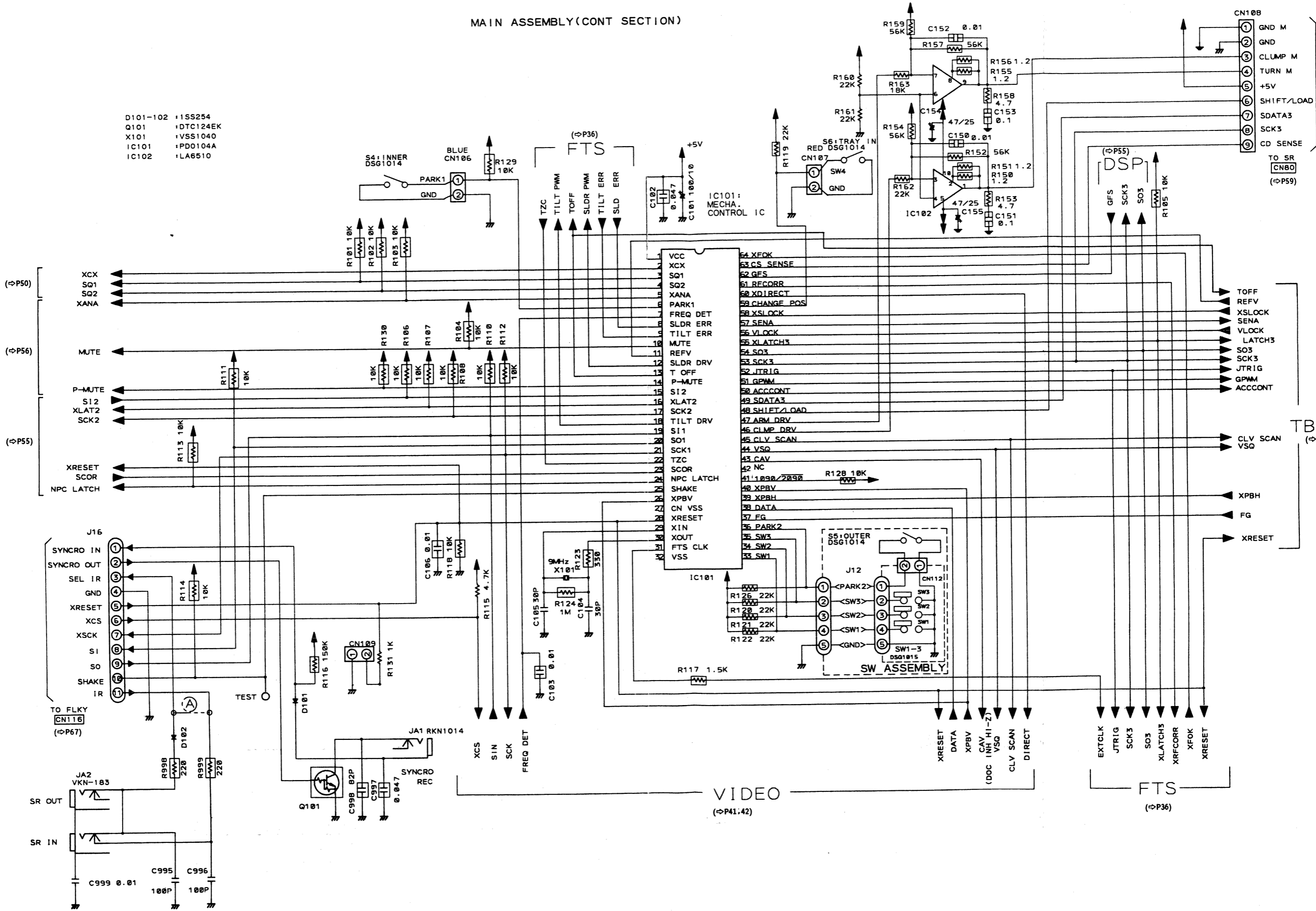

5.8 AUDIO ASSEMBLY (AFM Section)

AUDIO ASSEMBLY (AFM SECTION)

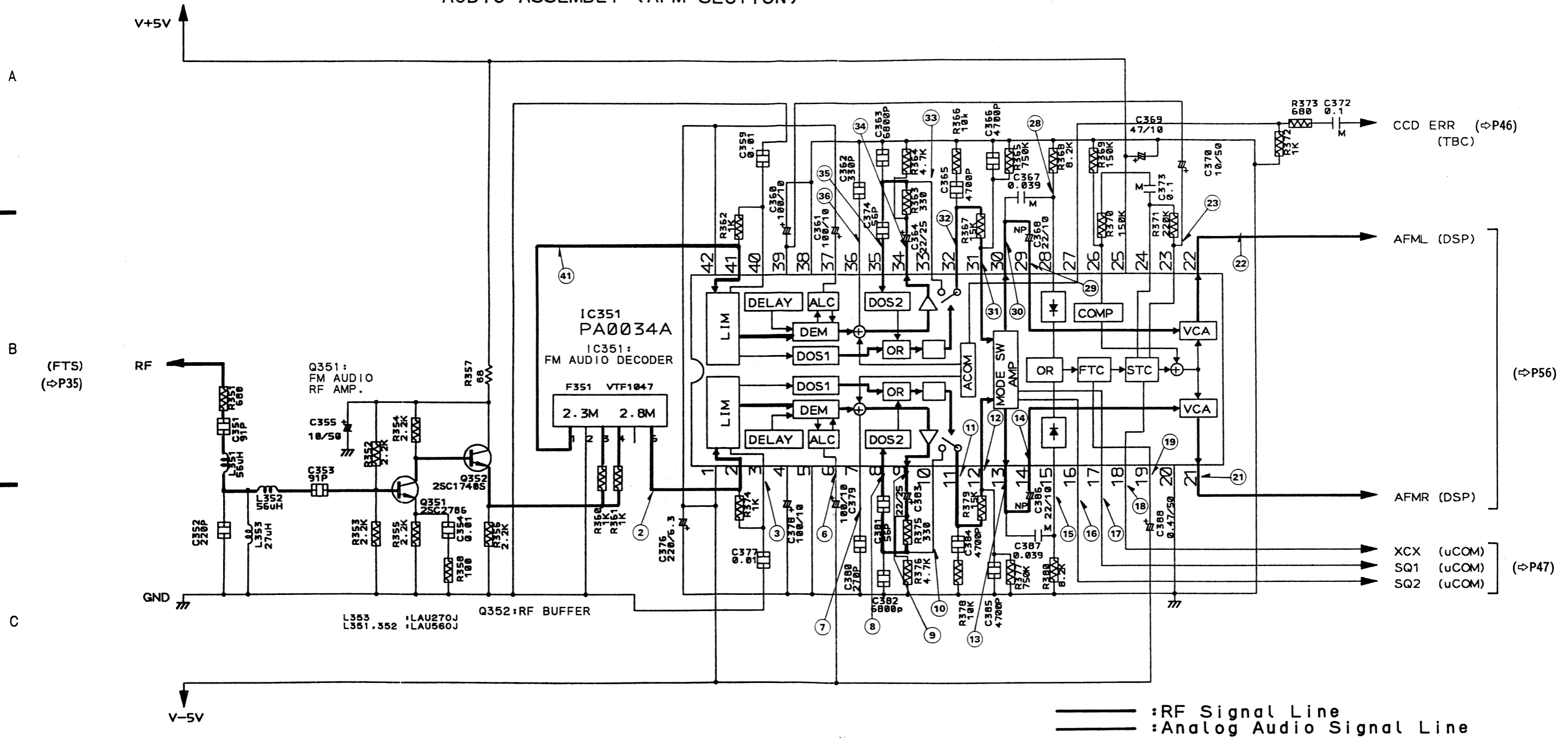

• IC351 (PA0034A)

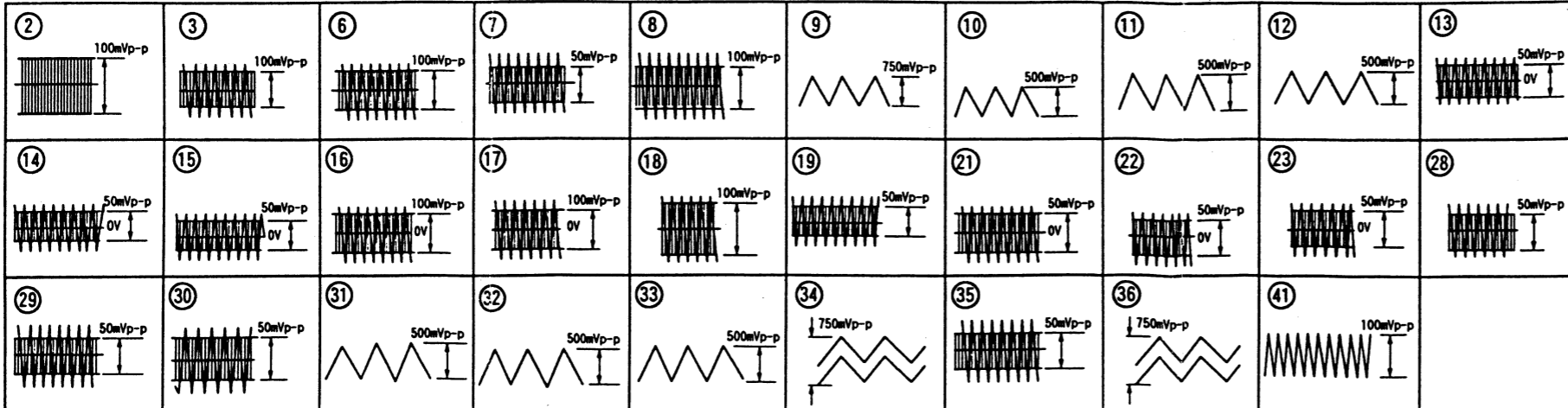

Note: Waveforms and voltages are at the PLAY state. IC351 (PA0034A)

Pin No.	Voltage	Pin No.	Voltage	Pin No.	Voltage
1	-5V	15	*	29	*
2	*	16	*	30	*
3	*	17	*	31	*
4	—	18	*	32	*
5	*	19	*	33	*
6	*	20	0	34	*
7	*	21	*	35	*
8	*	22	*	36	*
9	*	23	*	37	—
10	*	24	0	38	—
11	*	25	5V	39	—
12	*	26	0	40	—
13	*	27	0	41	*
14	*	28	*	42	-5V

*: Refer to Waveforms

1 | 2 | 3 | 4 | 5

A

A

HEPB ASSEMBLY

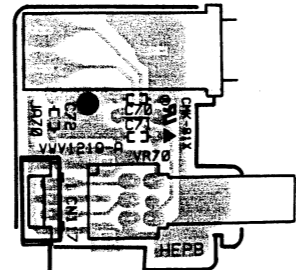

B

B

AUDIO ASSEMBLY

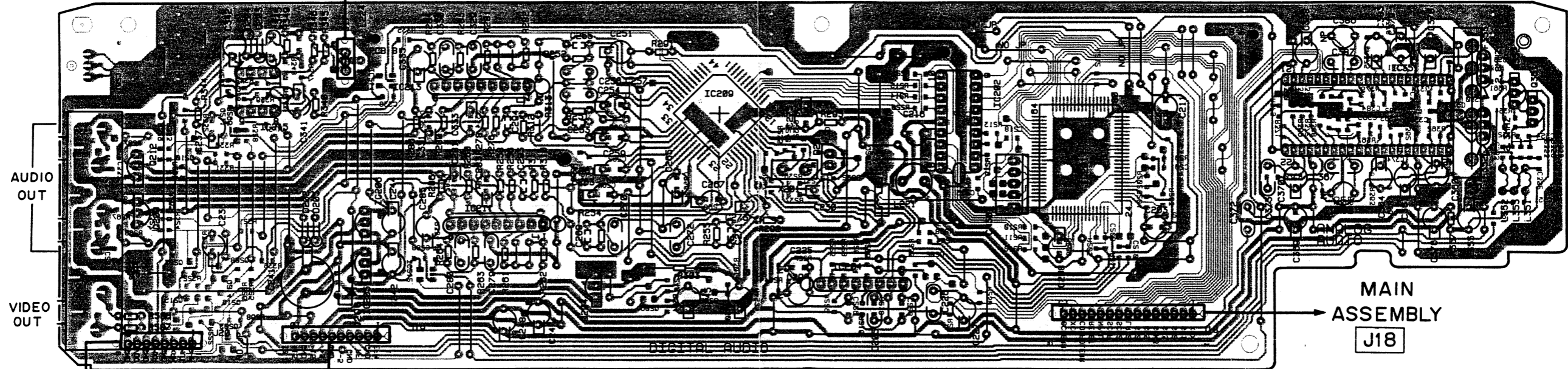

C

C

Q212	IC215	IC206	IC213	Q204	IC209	IC204	IC202	IC201	IC351	Q352
Q209	01S0	IC205	IC211		20S0 20S0	10S0	S0S0			Q351
	11S0									
	70S0 80S0	50S0	41S01							
	0S03 0S08 0S07		1S01							
	0S13 - 0S16		1S01							

MAIN ASSEMBLY
J20

MAIN ASSEMBLY
J19

MAIN ASSEMBLY
J18

D

D

1 | 2 | 3 | 4 | 5 | 6

This P.C.B. connection diagram is viewed from the foil side.

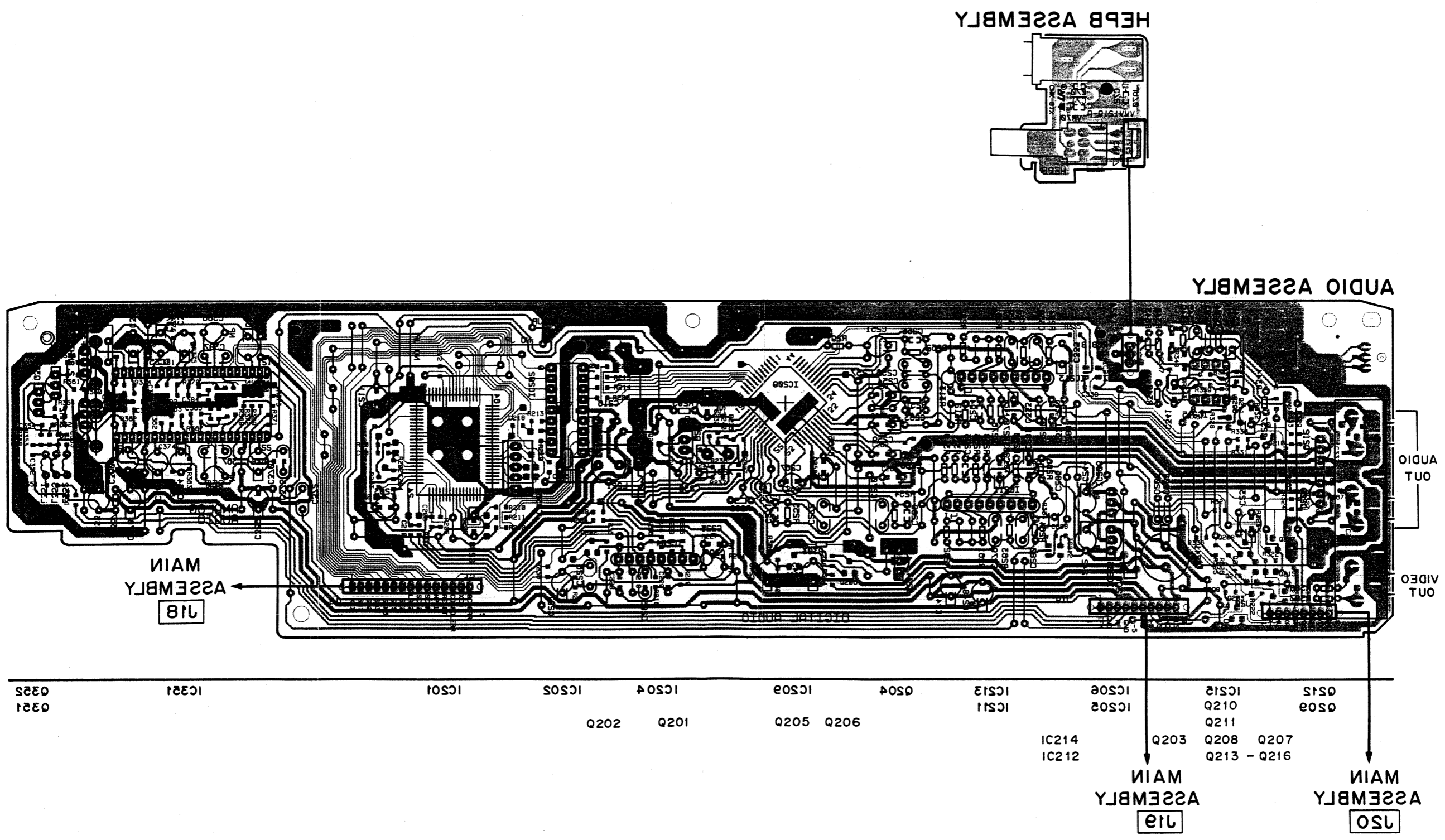

5.9 AUDIO ASSEMBLY(Digital Audio Section)

AUDIO ASSEMBLY(D.AUDIO SECTION)

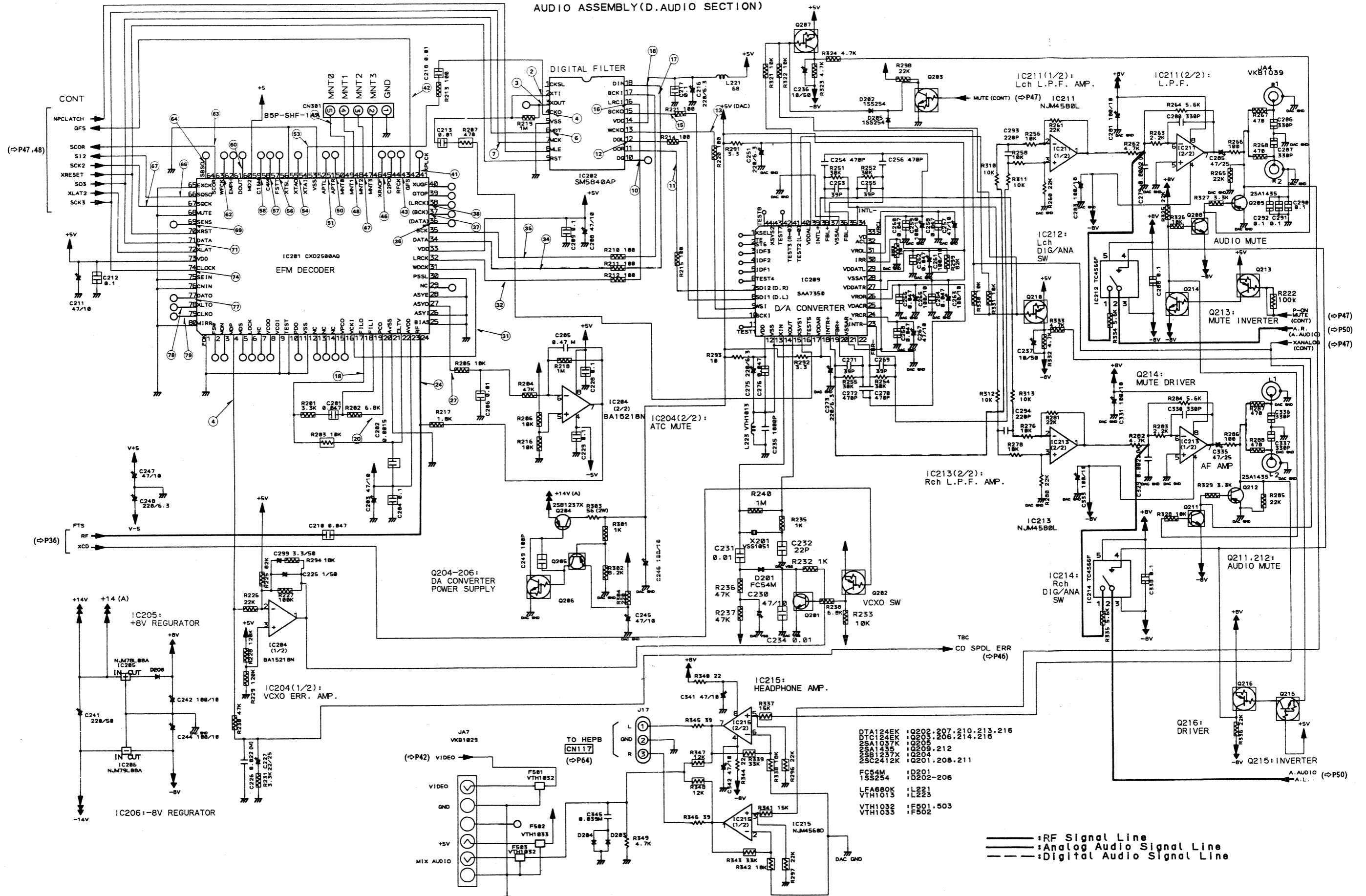

Note: Waveforms and voltages are at the PLAY
IC201 (CXD2500AQ)

Pin No.	Voltage	Pin No.	Voltage	Pin No.	Voltage	Pin No.	Voltage	Pin No.	Voltage	Pin No.	Voltage
1	0	15	0	29	0	43	*	57	*	71	*
2	0	18	4.8	30	0	44	0	58	*	72	5
3	0	17	0	31	*	45	4.8	59	5	73	5
4	*	18	*	32	*	46	*	60	*	74	*
5	0	19	2.4	33	4.8	47	*	61	5	75	0
6	4.8	20	*	34	*	48	*	62	*	76	0
7	0	21	0	35	*	49	*	63	*	77	*
8	4.8	22	2.3	36	*	50	*	64	*	78	*
9	0	23	4.8	37	*	51	*	65	0	79	*
10	0	24	*	38	*	52	0	66	*	80	0
11	0	25	0	39	0	53	*	67	*		
12	0	26	0	40	4.8	54	*	68	0		
13	0	27	*	41	*	55	0	69	*		
14	0	28	0	42	*	56	*	70	5		

IC202 (SM5840AP)

Pin No.	Voltage	Pin No.	Voltage
1	5	10	*
2	*	11	*
3	*	12	*
4	*	13	*
5	0	14	5
6	*	15	*
7	*	16	*
8	5	17	*
9	5	18	*

*: Refer to Waveforms

IC201 (CXD2500AQ)

IC202 (SM5840AP)

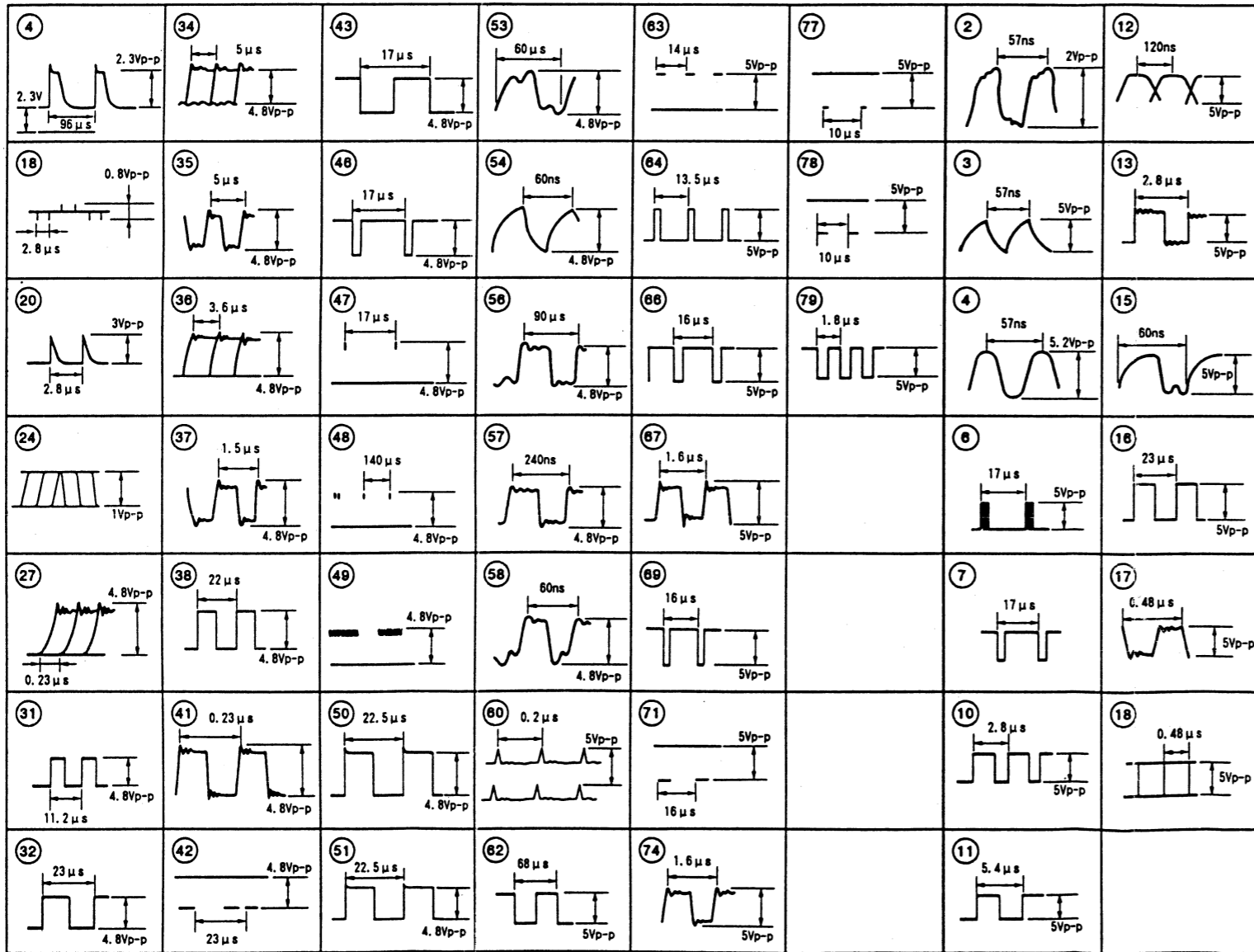

A

B

C

D

5.10 MSWB ASSEMBLY

A

B

C

D

TO MAIN
(CONT)
SECTION
CN108
(P48)

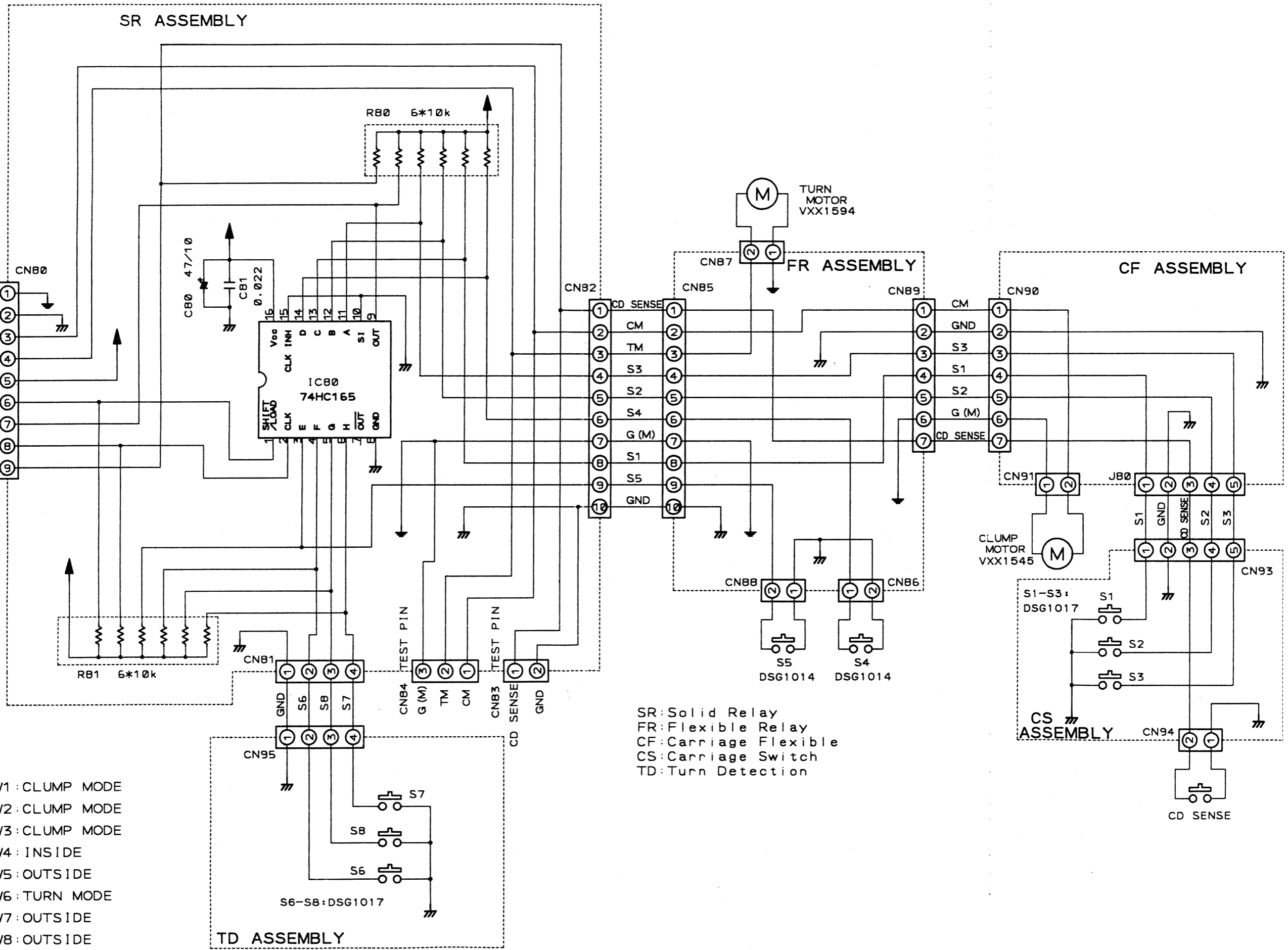

- SW1 : CLUMP MODE
- SW2 : CLUMP MODE
- SW3 : CLUMP MODE
- SW4 : INSIDE
- SW5 : OUTSIDE
- SW6 : TURN MODE
- SW7 : OUTSIDE
- SW8 : OUTSIDE

SR: Solid Relay
FR: Flexible Relay
CF: Carriage Flexible
CS: Carriage Switch
TD: Turn Detection

This P.C.B. connection diagram is viewed from the parts mounted side.

This P.C.B. connection diagram is viewed from the foil side.

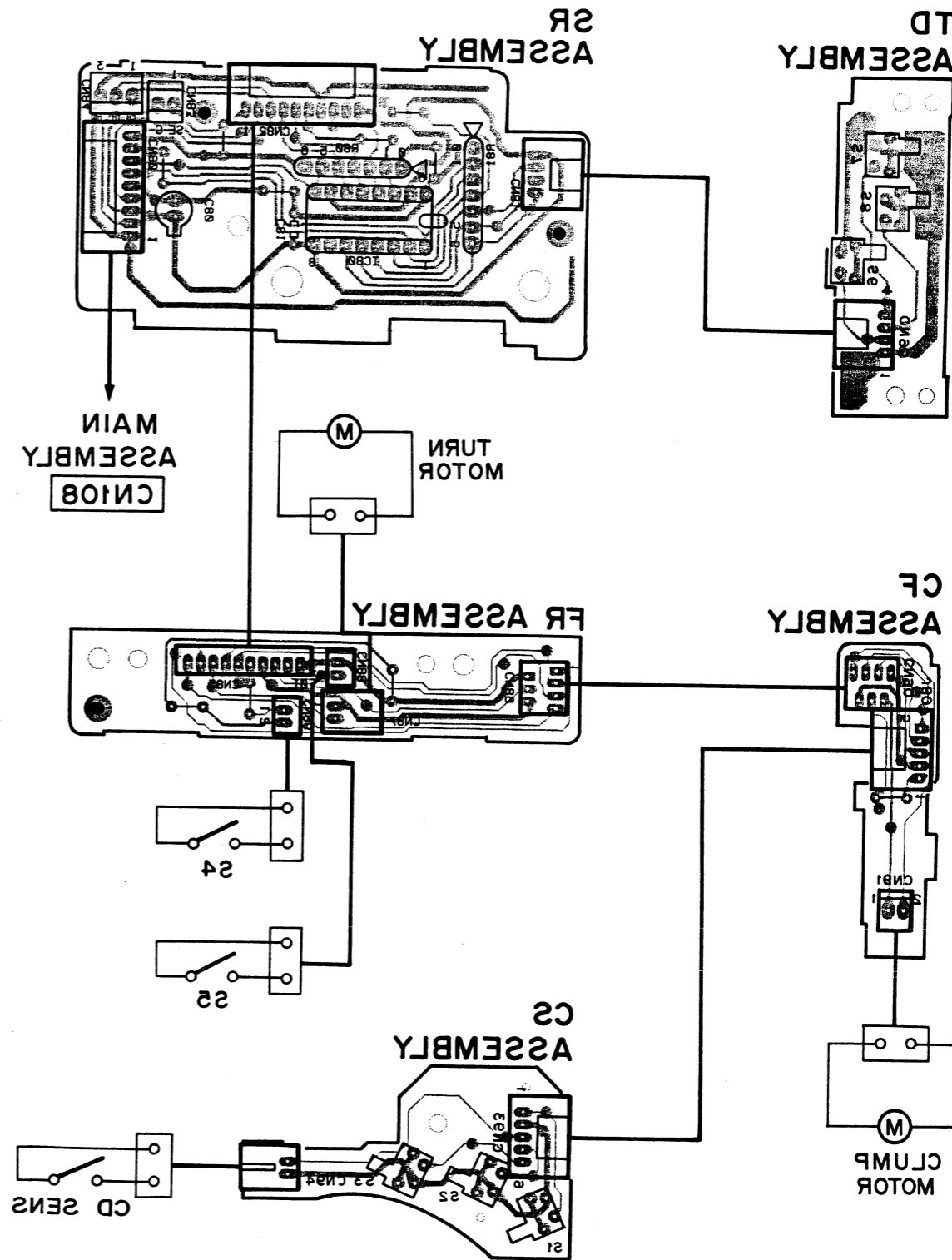
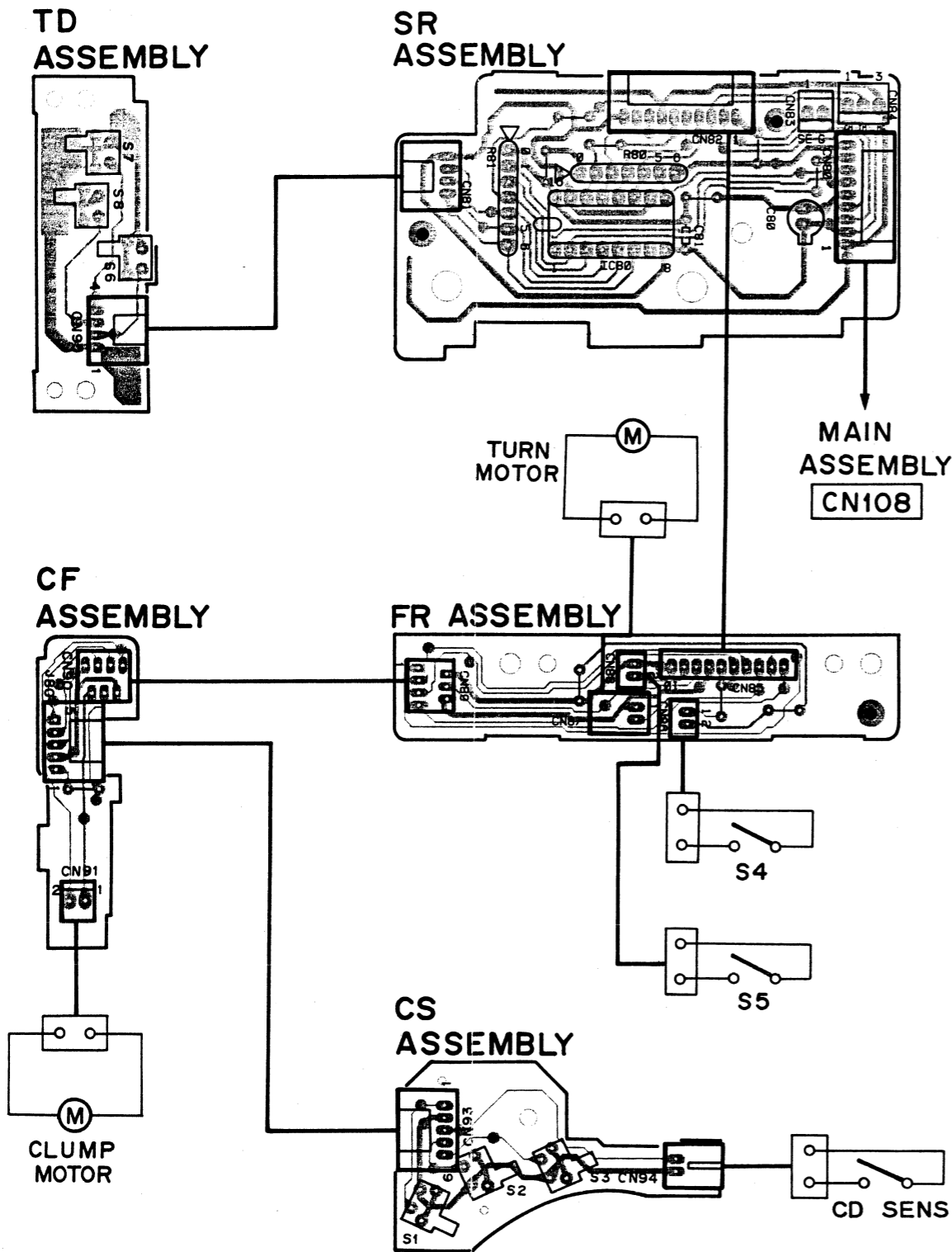

A

B

C

D

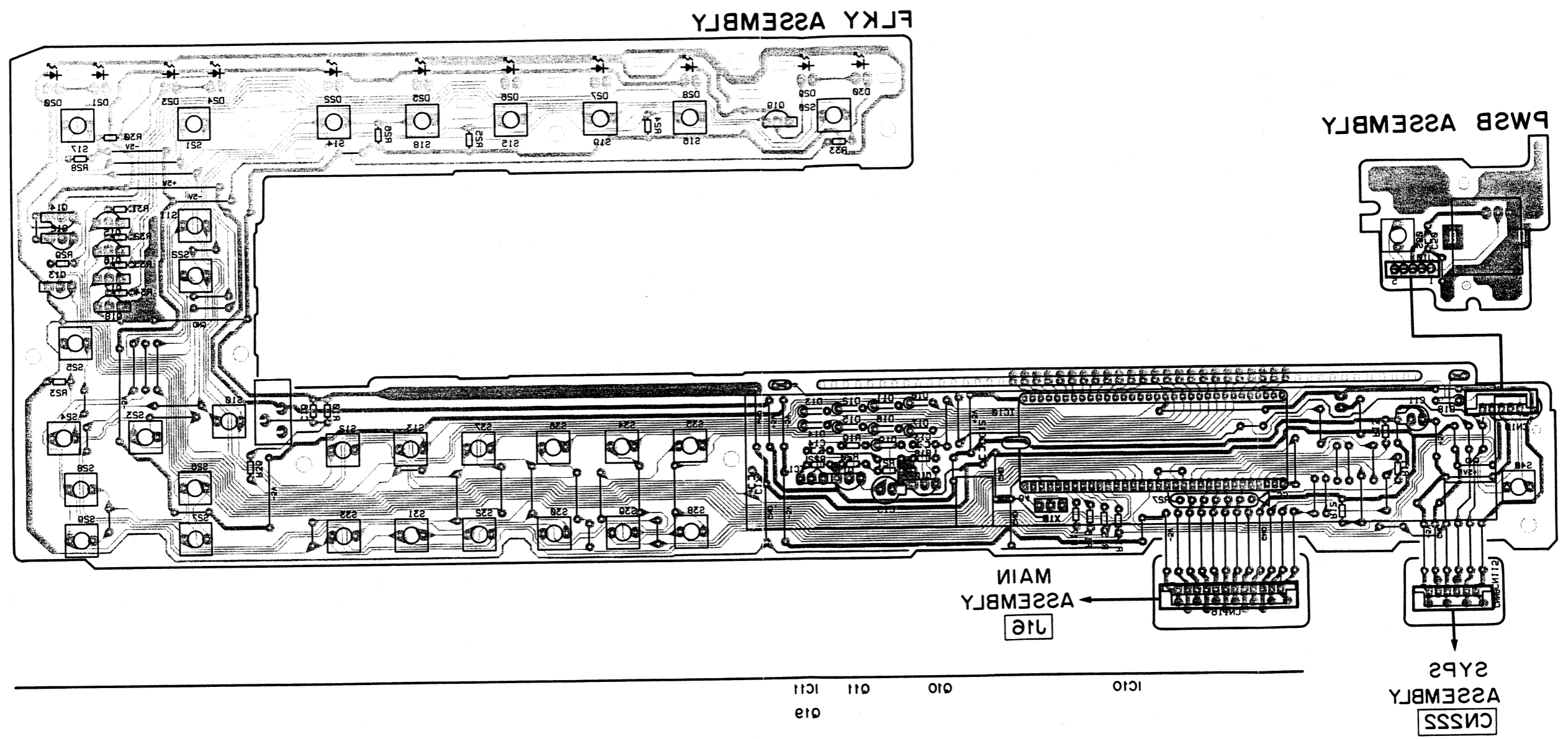

This P.C.B. connection diagram is viewed from the foil side.

5.11 FLKY, PSWB AND HEPB ASSEMBLIES

A

FLKY ASSEMBLY

PSWB ASSEMBLY

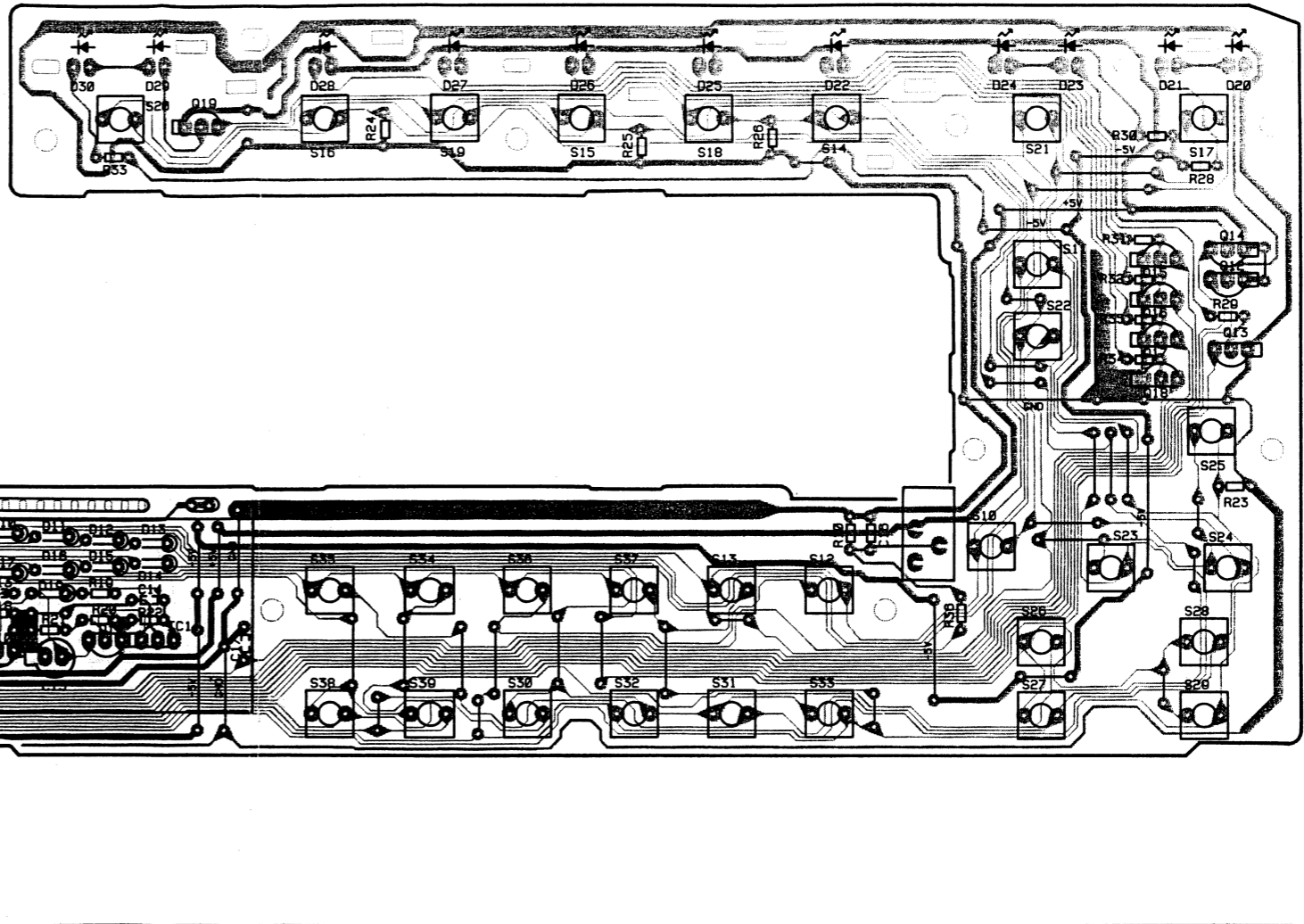
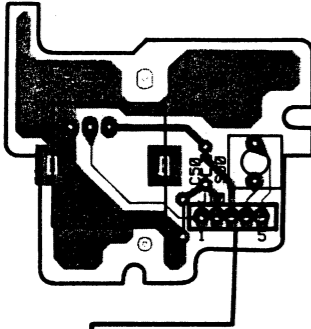

B

C

MAIN ASSEMBLY
J16

SYPS ASSEMBLY
CN222

IC10

Q10

Q11

IC11

Q19

D

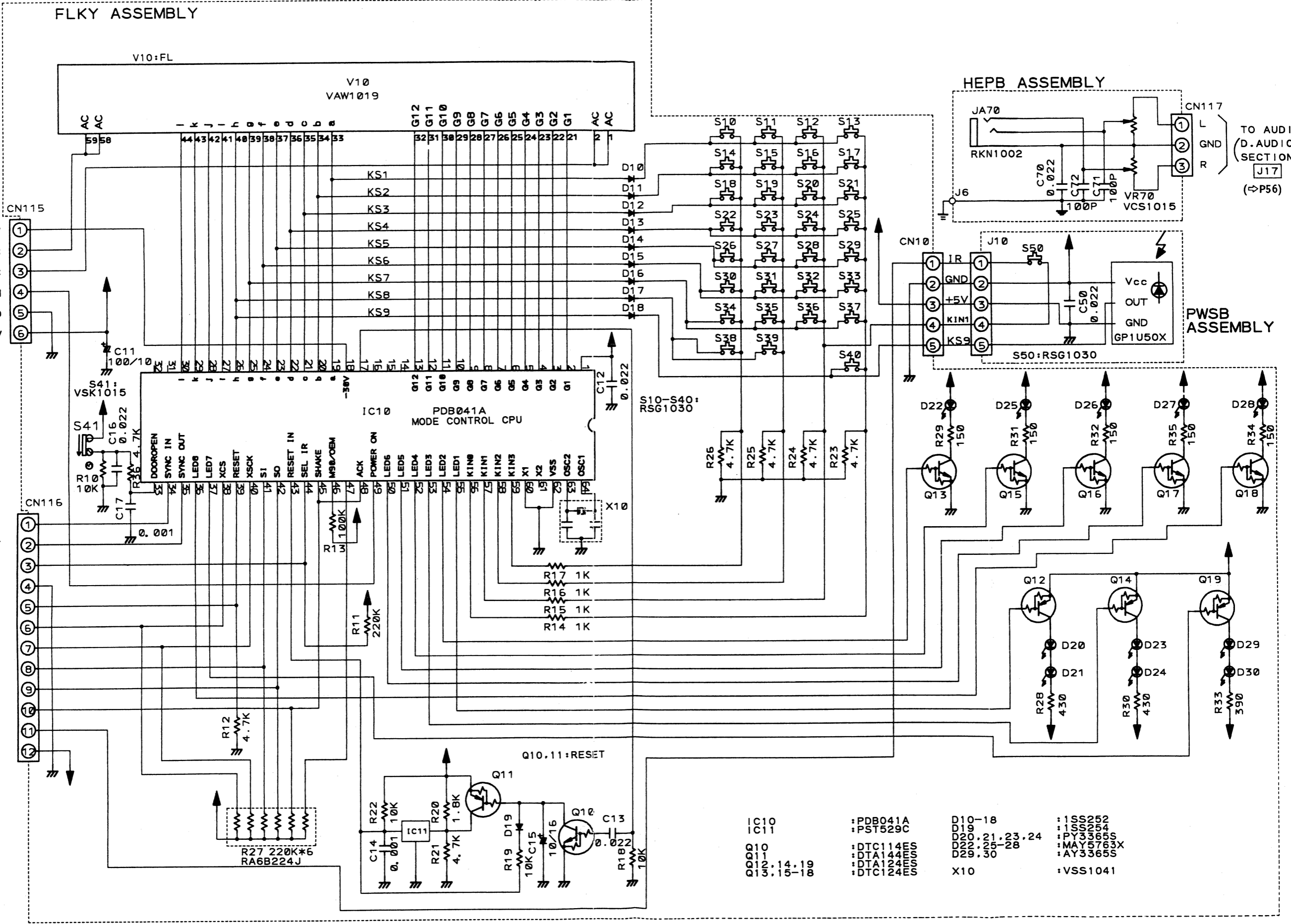

- | | | | |
|--------|------------|-----------------|-------------|
| IC10 | : PDB041A | D10-18 | : 1S5 |
| IC11 | : 75T529C | D19 | : 1G55 |
| Q00010 | : DTC114ES | D20, 21, 23, 24 | : PY360254 |
| Q12-14 | : DTA144ES | D22, 25-28 | : MAY360255 |
| Q15-18 | : DTA124ES | D29, 30 | : AY33655X |
| Q19 | : DTC124ES | X10 | : VSS1041 |

A

B

C

D

A

B

C

D

6. ELECTRICAL PARTS LIST

NOTES:

- Parts without part number cannot be supplied.
- Parts marked by "●" are not always kept in stock. Their delivery time may be longer than usual or they may be unavailable.
- The Δ mark found on some component parts indicates the importance of the safety factor of the part. Therefore, when replacing, be sure to use parts of identical designation.
- When ordering resistors, first convert resistance values into code form as shown in the following examples.

Ex.1 When there are 2 effective digits (any digit apart from 0), such as 560 ohm and 47k ohm (tolerance is shown by J = 5%, and K = 10%).

560Ω 56 × 10¹ 561 RD1/4PS561J

47kΩ 47 × 10³ 473 RD1/4PS473J

0.5Ω 0R5 RD2H0R5K

1Ω 010 RD1P010K

Ex.2 When there are 3 effective digits (such as in high precision metal film resistors).

5.62kΩ 562 × 10¹ 5621 RD1/4SR5621F

Miscellaneous Parts

Mark No.	Description	Parts No.
●	Mother assembly	VWM1198
	MAIN assembly	
	FG assembly	
	SW assembly	
	AUDIO assembly	
●	SYPS assembly	VWR1108
●	FLKB assembly	VWM1199
	FLKY assembly	
	PSWB assembly	
	HEPB assembly	
	MSWB assembly	
	SR assembly	
	FR assembly	
	CF assembly	
	CS assembly	
	TD assembly	
Δ	FU201, 202 Fuse (3A)	VEK-018
Δ	FU203, 204 Fuse (1A)	REK-080
Δ	Power transformer	VTT1096
Δ	Strain relief	CM-22C
Δ	AC power cord	PDG1015
	S4, S5 Push switch (INNER, OUTER)	DSG1014
	S6 Push switch (TRAY IN)	DSG1014
	Carriage motor assembly	VXX1261
	Loading motor assembly	VXX1262
	Spindle motor assembly	VXA1474
	Pre-pickup assembly	VXX1413
●	Servo mechanism base assembly-S	VXX1583

●MOTHER ASSEMBLY (VWM1198)

MOTHER assembly is composed of the MAIN, FG, SW and AUDIO assemblies.

MAIN ASSEMBLY

SEMICONDUCTORS

Mark No.	Description	Parts No.
	IC603, IC802	BA15218N
	IC801	CXA1081S
	IC403	CXL1009P
	IC102, IC804	LA6510
	IC602	NJM4558S
	IC404	PA0017
	IC401	PA5013A
	IC405	PD0093A
	IC101	PD0104A
	IC402	PM0001
	IC601	PM3002
	IC803	PM3003
	Q403, Q613, Q820, Q824, Q826, Q829, Q830	DTA124EK
	Q101, Q606, Q608, Q811, Q823, Q827, Q828, Q835	DTC124EK
	Q601	FMW2
	Q457, Q496, Q511, Q581, Q609, Q615, Q806, Q808, Q812, Q819, Q832	2SA1037K
	Q603, Q605	2SA933S
	Q816, Q818	2SB1185
	Q401	2SB1237X
	Q582, Q583, Q602, Q604	2SC1740S
	Q431, Q432, Q456, Q497-Q500, Q541, Q607, Q610, Q612, Q614, Q801-Q805, Q807, Q809, Q810, Q814, Q825, Q833	2SC2412K
	Q815, Q817	2SD1762
	Q402, Q822	2SD1858X
	Q821	2SK184

Mark No.	Description	Parts No.	Mark No.	Description	Parts No.
	D101, D102, D601-D604, D607-D611, D801, D804-D808	1SS254	C529, C536	CCSQCH910J50	
			C818	CCSLSL471J50	
			C819	CCSLSL561J50	
			C530	CEALNP100M16	
			C537	CEAL010M50	
COILS AND FILTERS					
Mark No.	Description	Parts No.	Mark No.	Description	Parts No.
	L601, L602	LAU101J	C522	CEAL100M16	
	L414, L415, L521, L541	LAU120J	C401	CEAL2R2M50	
	L801, L803	LAU151J	C501, C521	CEAL470M16	
	L496	LAU180J	C866	CEANPR47M50	
	L497, L802	LAU181J	C863	CEANP100M16	
	L412, L413, L523	LAU220J	C616, C850	CEANP2R2M50	
	L441	LAU270J	C618	CEANP220M10	
	L411	LAU330J	C870	CEANP470M10	
	L433	LAU390J	C436, C471, C808, C814, C816, C823, C840	CEAS010M50	
	L416, L431	LAU430J			
	L603	LAU470J	C855, C864, C902	CEAS100M50	
	L522	LAU560J	C101, C434, C445, C457, C489, C490, C582	CEAS101M10	
	L432	LAU620J			
	L511	LAU820J	C612, C835, C836, C841, C876, C877	CEAS220M25	
	L457, L458	LFA221J	C601, C857, C859	CEAS221M6R3	
	L456	LFA471J	C472, C475, C476	CEAS3R3M50	
	L524	LFA561K	C443, C621	CEAS4R7M50	
	L901, L902 Ferrite beads	VTH1015	C428, C464, C465, C499, C502, C512, C542, C622, C641, C642, C896, C897	CEAS470M10	
	F351 BPF (2.30, 2.81MHZ)	VTF1047	C154, C155, C484	CEAS470M25	
	F501, F503	VTH1032			
	F502	VTH1033	C583	CEAS471M6R3	
			C842, C845	CEJANP100M16	
			C446, C614, C650, C824, C849, C861, C865, C873, C901	CFTXA103J50	
			C615, C832, C838, C874, C878, C880	CFTXA104J50	
			C514	CFTNA104J50	
CAPACITORS					
Mark No.	Description	Parts No.	Mark No.	Description	Parts No.
	VC901 Ceramic trimmer (20P)	VCM-008	C807	CFTXA124J50	
	C104, C105	CCCCH300J50	C830	CFTNA154J50	
	C837, C871	CCCSL331J50	C617, C843	CFTXA223J50	
	C817	CCSQCH050C50	C474, C604, C852, C900	CFTXA224J50	
	C441	CCSQCH070D50	C827, C867	CFTXA333J50	
	C438, C450, C497, C500, C895	CCSQCH100D50			
	C411, C456, C461, C586, C603, C658, C810, C811, C822, C995, C996	CCSQCH101J50	C848, C869, C888	CFTXA473J50	
	C417, C418	CCSQCH120J50	C610	CFTXA563J50	
	C413, C509, C528	CCSQCH151J50	C517, C847, C868	CFTXA683J50	
	C423, C424, C624-C627, C629, C655, C659	CCSQCH180J50	C883	CFTXA823J50	
			C999	CKCYF103Z50	
			C515	CFTNA683J50	
	C485, C516, C806	CCSQCH220J50	C875, C879	CKSQYB562K50	
	C414	CCSQCH221J50	C854, C998	CKSQYB821K50	
	C415, C437, C451, C510, C812, C815	CCSQCH270J50	C103, C106, C150, C152, C425, C426, C458-C460, C486, C535, C628, C643-C646, C651-C653, C801-C803, C828, C829, C856	CKSQYF103Z50	
	C463	CCSQCH271J50			
	C447, C462	CCSQCH330J50	C151, C153, C403, C404, C427, C429, C435, C442, C479, C480, C503, C505, C506, C511, C513, C526, C531, C543, C584, C585, C851, C858, C860, C881, C882	CKSQYF104Z25	
	C416, C433, C440, C496, C524, C804	CCSQCH390J50			
	C412, C419, C420, C439, C546, C890, C891, C893	CCSQCH470J50			
	C545, C809, C813	CCSQCH680J50			
	C498, C654	CCSQCH820J50			

Mark No.	Description	Parts No.
	C102, C407, C408, C432, C448, C449, C466, C467, C473, C478, C483, C487, C488, C504, C507, C508, C527, C544, C602, C623, C805, C820, C997	CKSQYF473Z25
	C605, C607, C839	CQMA102J50
	C608, C834	CQMA152J50
	C620	CQMA222J50
	C444, C611, C656, C657, C899	CQMA272J50
	C613, C619, C853	CQMA332J50
	C898	CQMA472J50
	C825	CQMA682J50
	C606	CQPA821J100

RESISTORS

Mark No.	Description	Parts No.
	VR601 Semi-fixed (1K Ω)	VRTB6VS102
	VR441, VR482, VR602, VR603 Semi-fixed (10K Ω)	VRTB6VS103
	VR605, VR606, Semi-fixed (2.2K Ω)	VRTB6VS222
	VR607 Semi-fixed (22K Ω)	VRTB6VS223
	VR608 Semi-fixed (33K Ω)	VRTB6VS333
	VR481, VR604, VR609 Semi-fixed (4.7K Ω)	VRTB6VS472
	VR521 Semi-fixed (4.7K Ω)	VRTG6VS472
	R131, R403, R431, R544, R585, R588, R603, R618, R629, R647, R649, R665, R666- R678, R691, R701- R703, R705, R709, R711, R849, R869, R873, R904, R910- R913, R918, R923, R934, R942	RD1/6PM□□□J
	R415, R416, R434, R438, R511, R680, R681- R683	RN1/6PQ□□□□F
	R850, R862	RS1LMF3R3J
	Other resistors	RS1/10S□□□J

OTHERS

Mark No.	Description	Parts No.
	X601 Crystal resonator (14,318MHz)	VSS1026
	X101 Ceramic resonator (9,00MHz)	VSS1040
	CN301 5P top post	B5P-SHF-1AA
	CN103 23P top connector	VKN1073
	JA1 Mini jack (CD-DECK SYNCHRO)	RKN1014
	JA7 RF pin jack (VHF ADAPTER OUTPUT)	VKB1029
	JA2 2P mini jack (CONTROL)	VKN-183

FG ASSEMBLY

SEMICONDUCTOR

Mark No.	Description	Parts No.
	Photo interrupter	GP1S51

SW ASSEMBLY

SWITCHES

Mark No.	Description	Parts No.
	S1-S3 Push switch (LOADING/TILT)	DSG1015

AUDIO ASSEMBLY

SEMICONDUCTORS

Mark No.	Description	Parts No.
	IC204	BA15218N
	IC201	CXD2500AQ
	IC215	NJM4560D
	IC211, IC213	NJM4580L
	IC205	NJM78L08A
	IC206	NJM79L08A
	IC351	PA0034A
	IC209	SAA7350
	IC202	SM5840AP
	IC212, IC214	TC4S66F
	Q202, Q207, Q210, Q213, Q216	DTA124EK
	Q203, Q206, Q214, Q215	DTC124EK
	Q205	2SA1037K
	Q209, Q212	2SA1435
	Q204	2SB1237X
	Q352	2SC1740S
	Q201, Q208, Q211	2SC2412K
	Q351	2SC2786
	D201	FC54M
	D202-D206	1SS254

COILS AND FILTERS

Mark No.	Description	Parts No.
	L353	LAU270J
	L351, L352	LAU560J
	L221	LFA680K
	L223 Ferrite beads	VTH1013
	L232, L233	LAU180J
	F351 BPF (2.30, 2.81MHz)	VTF1047

CAPACITORS

Mark No.	Description	Parts No.
	C253, C255, C269, C271	CCPU\$ L390J50
	C249	CCSQCH101J50
	C232	CCSQCH220J50
	C352	CCSQCH221J50
	C380	CCSQCH271J50
	C374, C381	CCSQCH560J50
	C351, C353	CCSQCH910J50
	C286, C287, C336, C337, C362	CCSQ\$ L331J50
	C225	CEANP010M50
	C368, C386	CEANP220M10

Mark No.	Description	Parts No.
C299		CEANP3R3M50
C388		CEASR47M50
C236, C237, C355, C370		CEAS100M50
C242, C244, C246, C259, C261, C263, C265, C281, C283, C331, C333, C360, C361, C378, C379		CEAS101M10
C227, C364, C383		CEAS220M25
C241		CEAS221M50
C216, C248, C251, C273, C275, C376		CEAS221M6R3
C203, C208, C211, C230, C245, C247, C257, C267, C341, C342, C369		CEAS470M10
C285, C335		CEAS470M25
C372, C373		CFTNA104J50
C226		CFTXA223J50
C345, C367, C387		CFTXA393J50
C205		CFTNA474J50
C279, C329		CFTXA222J50
C254, C256, C270, C272		CFTXA471J50
C293, C294		CKPUYB221K50
C280, C330		CCCSL331J50
C202		CKSQYB152K50
C365, C366, C384, C385		CKSQYB472K50
C363, C382		CKSQYB682K50
C206, C213, C218, C231, C234, C354		CKSQYF103Z50
C359, C377		
C204, C209, C212, C217, C228, C229		CKSQYF104Z25
C288, C290-C292, C338		
C201, C210, C258, C260, C262, C264, C266, C268, C276		CKSQYF473Z25
C235		CQMA102J50

RESISTORS

Mark No.	Description	Parts No.
R251, R252, R254-R256, R258, R260, R261-R264, R266, R276, R278, R280, R281-R284, R286, R293, R310, R311-R313, R340, R344-R346, R349, R357, R586, R587		RD1/6PM□□□J
R303		RS2LMF560J
Other resistors		RS1/10S□□□J

OTHERS

Mark No.	Description	Parts No.
X201	Crystal resonator (16MHz)	VSS1051
CN301	5P top post	B5P-SHF-1AA
JA4	6P pin jack (AUDIO, VIDEO OUT)	VKB1039

●FLKB ASSEMBLY (VWM1199)

FLKB assembly is composed of the FLKY, PSWB, and HEPB assemblies.

FLKY ASSEMBLY

SEMICONDUCTORS

Mark No.	Description	Parts No.
IC10		PDB041A
IC11		PST529C
Q12, Q14, Q19		DTA124ES
Q11		DTA144ES
Q10		DTC114ES
Q13, Q15-Q18		DTC124ES
D29, D30		AY3365S
D22, D25-D28		MAY5763X
D20, D21, D23, D24		PY3365S
D10-D18		1SS252
D19		1SS254

SWITCHES

Mark No.	Description	Parts No.
S10-S40	Tact switch	RSG1030
	(DISPLAY, OPEN/CLOSE, PGM, DISC NUMBER, DIRECT SEARCH(0-9,+10) HILITE, DIRECT CD, RANDOM, STOP (■), EDIT, ADLC, PLAY/PAUSE (▶/) SKIP(◀◀, ▶▶), SCAN(◀◀, ▶▶), POWER)	
S41	Door switch	VSK1015

CAPACITORS

Mark No.	Description	Parts No.
C11		CEAL101M6R3
C15		CEAL100M16
C14, C17		CKPUYB102K50
C12, C13, C16		CKPUYF223Z25

RESISTORS

Mark No.	Description	Parts No.
R27		RA6S224J
Other resistors		RD1/6PM□□□J

OTHERS

Mark No.	Description	Parts No.
V10	Fluorescent indicator tube	VAW1019
X10	Ceramic resonator (6.00MHz)	VSS1041
FL	spacer	VEB1125

PSWB ASSEMBLY

SWITCH

Mark No.	Description	Parts No.
S50	Tact switch (POWER)	RSG1030

CAPACITORS

Mark No.	Description	Parts No.
C50		CKPUYF223Z25

OTHERS

Mark No.	Description	Parts No.
	Remote control sensor unit	GP1U50X

HEPB ASSEMBLY

CAPACITORS

Mark No.	Description	Parts No.
C71, C72		CKPUYB101K50
C70		CKPUYF223Z25

RESISTOR

Mark No.	Description	Parts No.
VR70	Double rotary volume (LEVEL)	VCS1015

OTHERS

Mark No.	Description	Parts No.
JA70	Headphone jack	RKN1002

●SYPS ASSEMBLY (VWR1108)

SEMICONDUCTORS

Mark No.	Description	Parts No.
△ IC201		ICP-N15
	IC202	ICP-N15
	IC206	ICP-N25
△ IC205		NJM78M05FA
	Q217	DTA114ES
	Q213	DTC114ES
	Q214, Q219	2SA933S
	Q202, Q203, Q205	2SB1185
△ Q207		2SB1238X
	Q218	2SC1740S
	Q201, Q204, Q206	2SD1762
	D220	MTZJ27A
	D102, D104	MTZJ5.1C
	D101, D103	MTZJ5.6B
△ D201, D202		S2VB20
△ D213, D214		1SR35-100AVL
	D222, D223	1SR35-100AVL
	D208, D209	1SS252
△ D216, D217		1SS252
	D212, D215	10ELS2

COIL

Mark No.	Description	Parts No.
△ L202	Line filter	VTL-157
△ L201	Coil (10mH)	VTL1008

CAPACITORS

Mark No.	Description	Parts No.
	C226, C231, C232, C242, C245	CEAS101M10
	C235	CEAS102M25
	C214, C215	CEAS2R2M50
	C209, C210	CEAS220M25
	C240, C243	CEAS221M10
	C223	CEAS221M25
	C219	CEAS221M50
	C213	CEAS471M35
	C208	CEAS472M10
	C207	CEAS682M10
	C212, C237, C238	CGCYX473M25
	C196-C199, C246	CKCYF103Z50
	C241, C244	CKPUYB102K50
	C201-C204	CKPUYF103Z25
△ C216		RCG-009
	C217	RCG-009
	C205, C206 (3,300μ/25)	VCH1095

RESISTORS

Mark No.	Description	Parts No.
△ R241		RD1/2PM225J
△ R221		RS1LMFR51J
	R239	RS1LMF4R7J
	R231	VCN1029
	Other resistors	RD1/6PM□□□J

MSWB ASSEMBLY

MSWB assembly is composed of the SR, FR, CF, CS and TD assemblies.

SR ASSEMBLY

SEMICONDUCTOR

Mark No.	Description	Parts No.
	IC80	HD74HC165P

CAPACITORS

Mark No.	Description	Parts No.
	C80	CEAL470M6R3
	C81	CKPUYF223Z25

RESISTORS

Mark No.	Description	Parts No.
	R80, R81	RA6S103J

FR ASSEMBLY**OTHER**

Mark	No.	Description	Parts No.
	CN89	7P side connector	VKN1156

CF ASSEMBLY**OTHER**

Mark	No.	Description	Parts No.
	CN90	7P side connector	VKN1156

CS ASSEMBLY**SWITCHES**

Mark	No.	Description	Parts No.
	S1-S3	Push switch (CLUMP MODE)	DSG1017

TD ASSEMBLY**SWITCHES**

Mark	No.	Description	Parts No.
	S6-S8	Push switch (TURN MODE, OUTSIDE)	DSG1017

HEAD ASSEMBLY**CAPACITOR**

Mark	No.	Description	Parts No.
	C1		CKSQYF473Z50
	C5		CKSYF105Z16

RESISTORS

Mark	No.	Description	Parts No.
	VR1	(10K)	VCP1040

7. DISASSEMBLY

7.1 REMOVING THE BONNET AND FRONT PANEL (Fig. 7-1, 2)

- ① Remove six screws (A) to remove the bonnet.
- ② To remove the front panel assembly, remove three screws (B) and lift the claws as shown in the figure and lower the front panel toward the front.

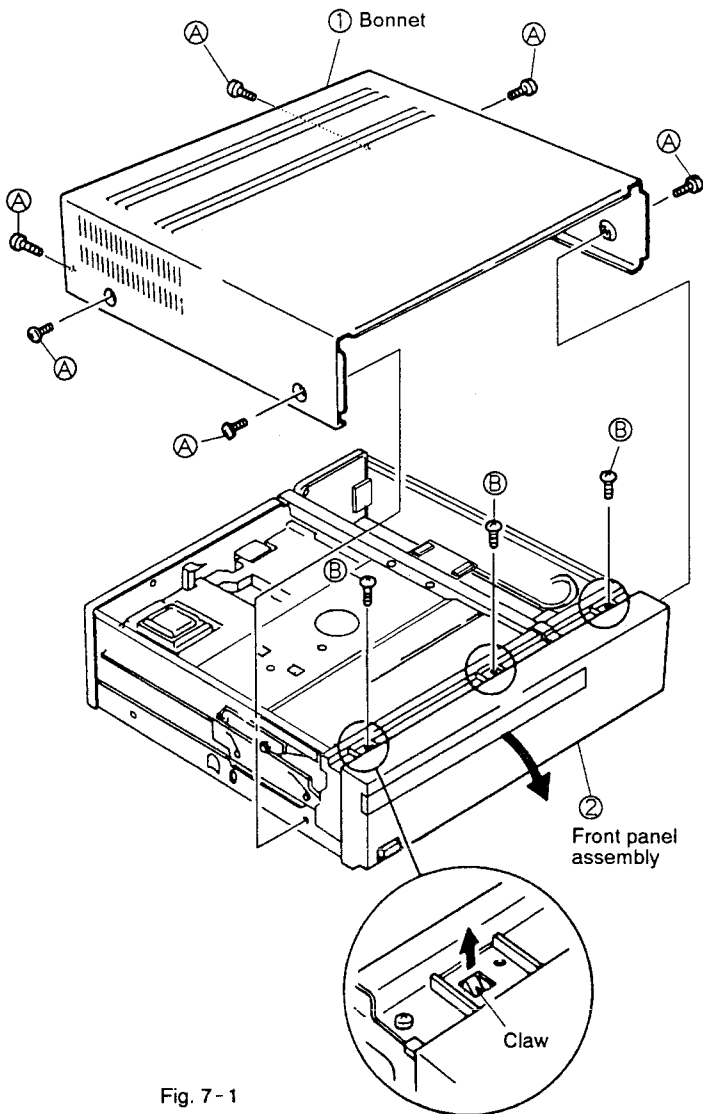

Fig. 7-1

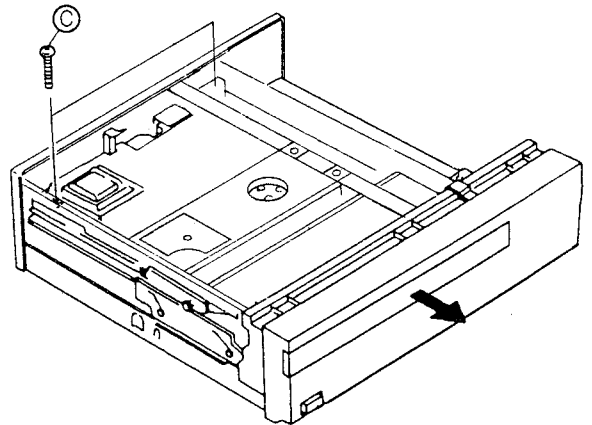

Fig. 7-2

7.2 REMOVING THE TRAY (Fig. 7-2, 3)

- ① Remove two stopper screws (C) shown in Fig. 7-2. When the power can be turned ON, press the OPEN (▲) button then pull the tray out from the player.
- ② When the power cannot be turned ON, remove the front panel (Fig. 7-1) and turn the gear pulley shown in Fig. 7-3 counterclockwise, and the tray will slide out toward the front.

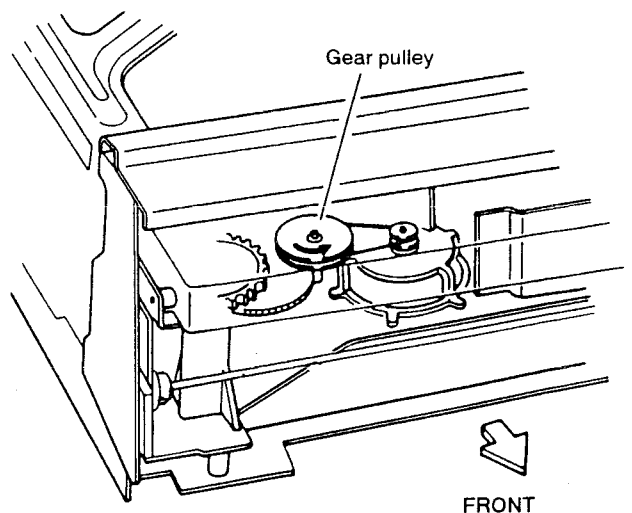
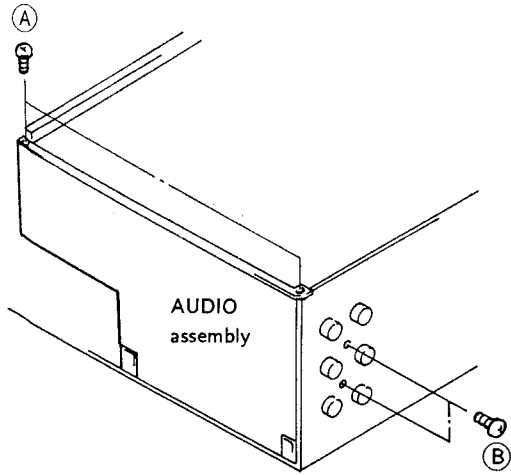

Fig. 7-3

7.3 REMOVING THE AUDIO AND MAIN ASSEMBLY

7.3.1 Removing the AUDIO assembly

① Remove two screws (A) and (B).



7.3.3 Diagnosis of the AUDIO and MAIN assembly

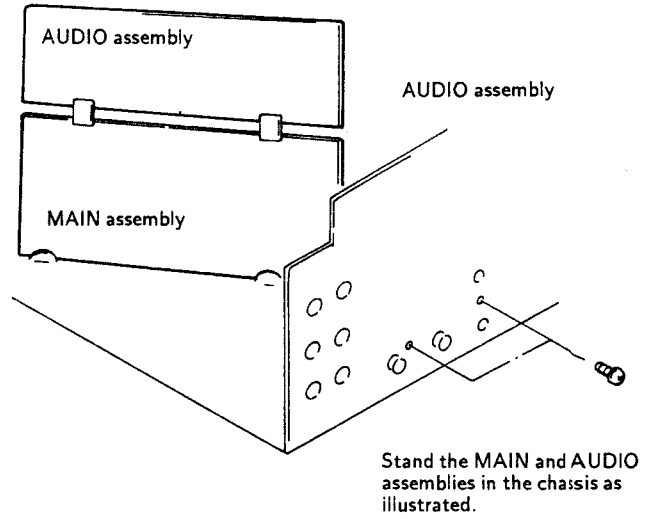

7.3.2 Removing the MAIN BOARD assembly

① Remove two screws (C).

② Remove two screws (D) from the rear side.

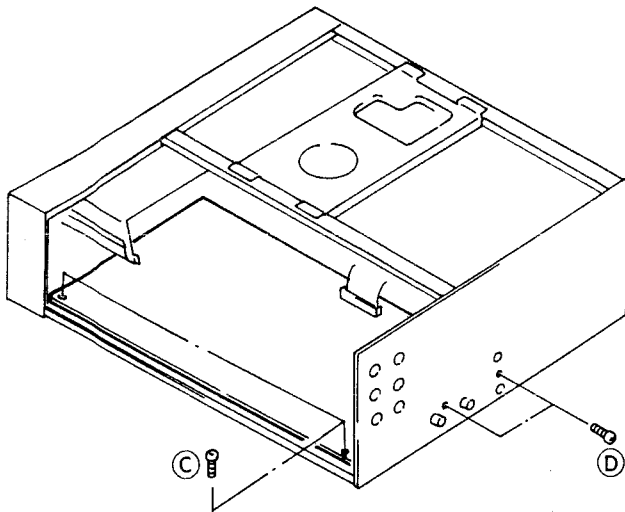

The groove for stand the MAIN assembly when diagnosing the Clamper arm mechanism. When diagnosing the clamper arm mechanism, disconnect the flexible cable.

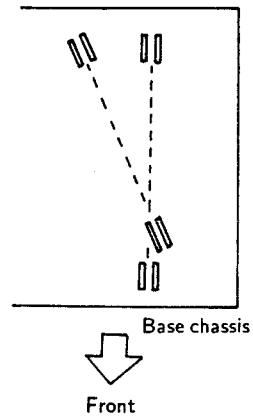

7.4 REMOVING THE CLAMPER ARM ASSEMBLY (See page 7 - 14)

- ① Remove four screws (E).

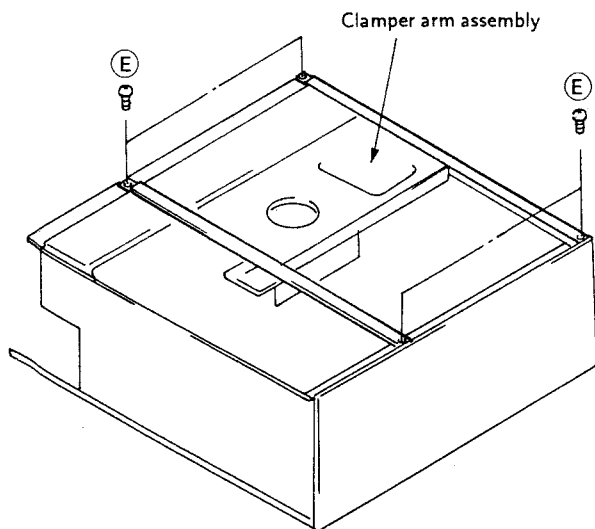

As to the detail refer to page 7 - 14.

7.5 REMOVING THE PICKUP ASSEMBLY (Fig 7-8)

- ① Remove the flexible cable from the connector and also remove the flexible cable installed at section (a).
- ② Remove a screw (A) holding the carriage shaft.
- ③ Raise the shaft in the direction of the arrow to remove the rack assembly.
- ④ Remove a hexagonal screw (B) and lift up the pickup assembly lightly and turn the pickup assembly in the direction of arrow (5).
- ⑤ Remove two screws (C) on the back of the pickup assembly.

Note: Make sure that the rack assembly is not close to the turntable when it is removed.

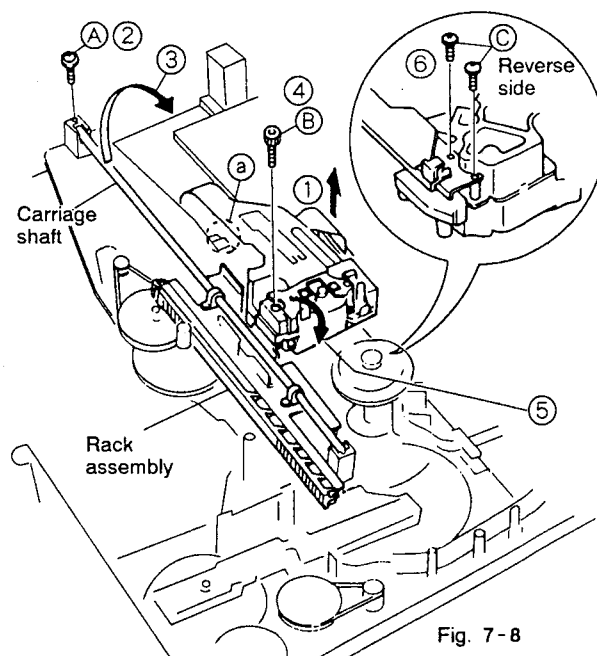

Fig. 7-8

7.6 REMOVING THE TILT SENSOR (Fig.7-9)

- ① Remove the connector (arrow A) of the flexible cable and release the claw (arrow B) to remove the tilt sensor.

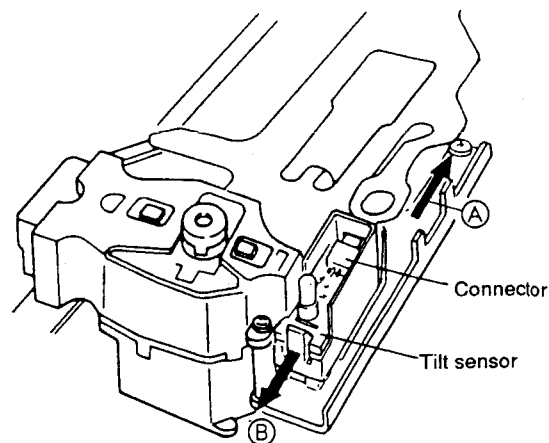

Fig. 7-9

**7.7 REMOVING THE MECHANISM SECTION
(Fig.7-10)**

Remove six screws (A), and the entire mechanism section can be removed.

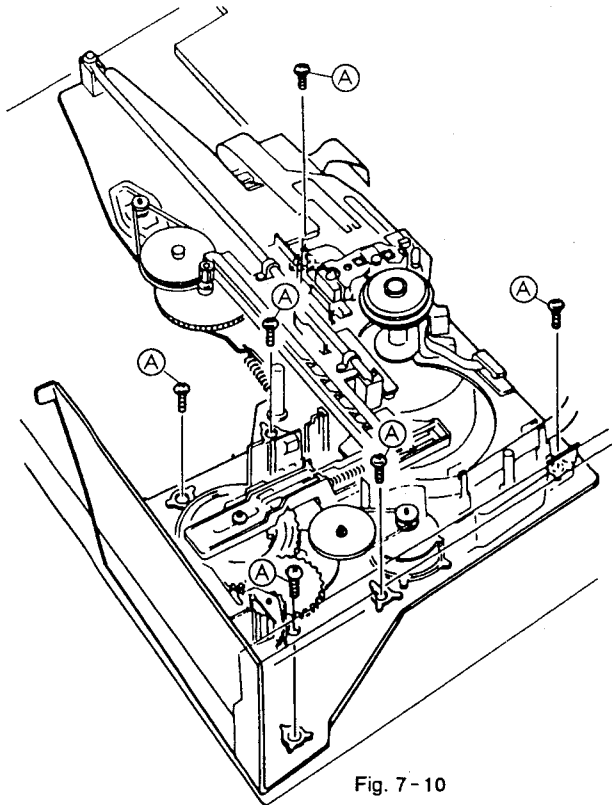

Fig. 7-10

7.8 REMOVING THE SLIDE CAM AND ROLLER PLATE ASSEMBLY(Fig.7-11)

- ① Set the player with the tray down.
- ② Remove three screws (A) and slide the slide cam toward the rear to remove it.
- ③ Remove the clamper arm (A) assembly (see page 77) after removing slide cam to remove the roller plate assembly.

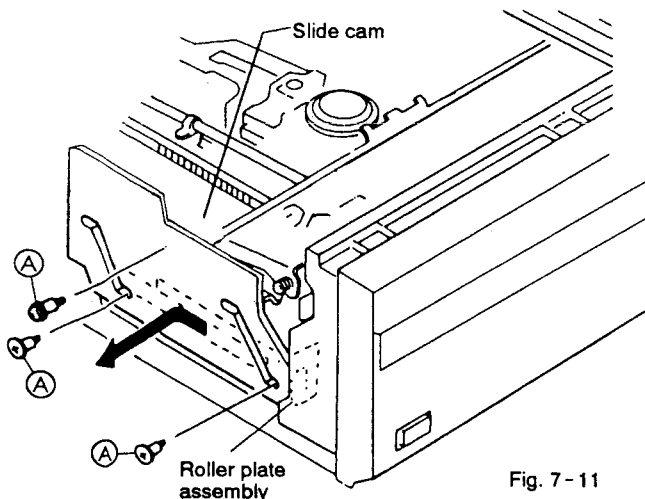

Fig. 7-11

7.9 ASSEMBLING THE MECHANISM SECTION

7.9.1 Positioning the gears

(Since the cam gears are used for the detection of all operation modes in this unit, the cam gears and the tray should be positioned correctly. Reassemble in the following procedure.)

- ① Position three switch levers so that they are nearly parallel (approx. 2mm), as shown in Fig. 7-12 (a).
- ② Insert the cam gear so that the end of the spiral groove on the upper surface of the cam gear comes to the position nearest to the shaft located at the front, as shown in Fig. 7-12 (b).

(In this case, the cam gear should be set in the position where the angle between the center line of the cam gear and the pin on the cam gear is 45°, by visual checking.)

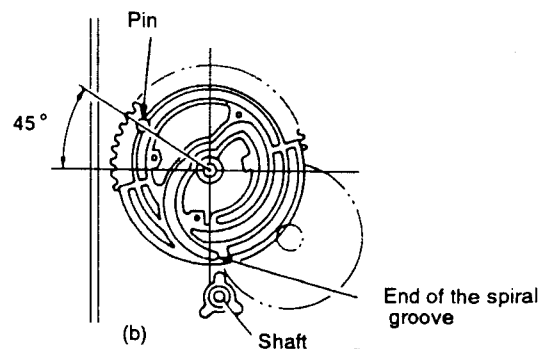
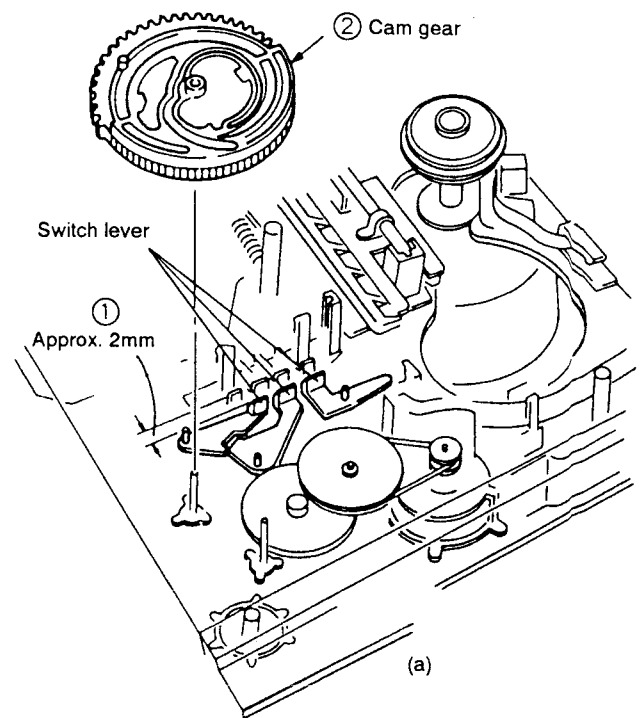

Fig. 7-12

- ③ Mount the spring slanting cam by raising the rack assembly in the direction of the arrow so that the tilt slide section comes under the rack assembly. Then, mount the cam spring. (Fig. 7-13 (a))
- ④ Insert the follow gear so that the "L"-shaped section of the follow gear comes to the end of the cam gear, as shown in Fig. 7-13 (b).

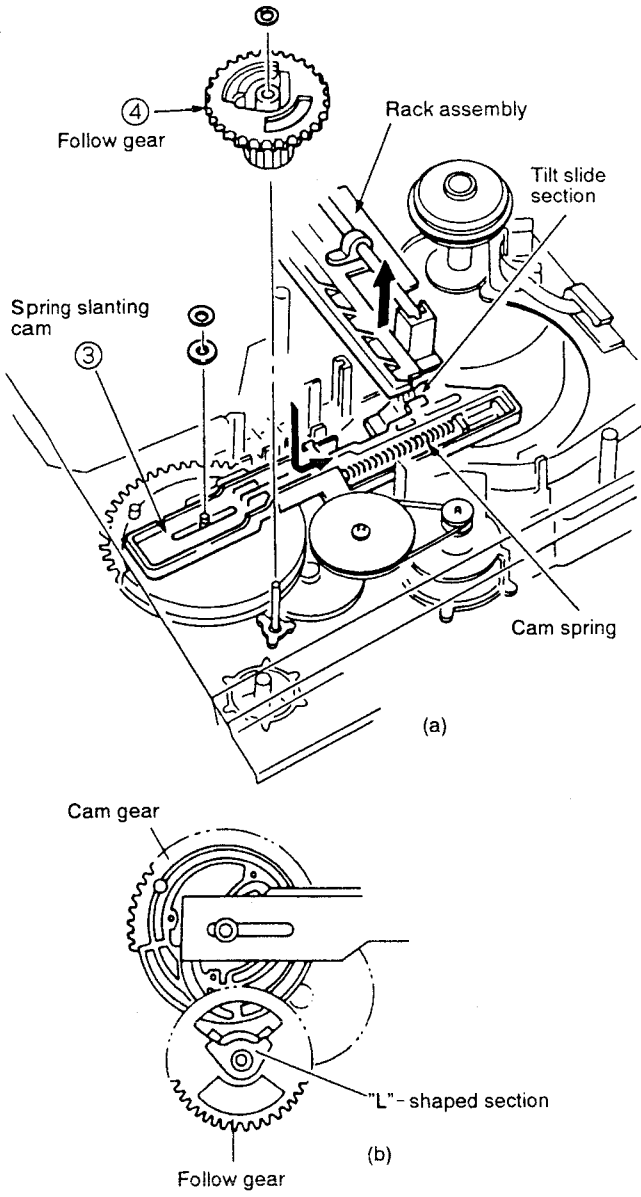

Fig. 7-13

- ⑤ Mount the roller plate assembly in the position where the tooth with the triangle mark (▼) of the follow gear is engaged with the dip of the gear with the short rib on the roller plate gear, as shown in Fig. 7-14.

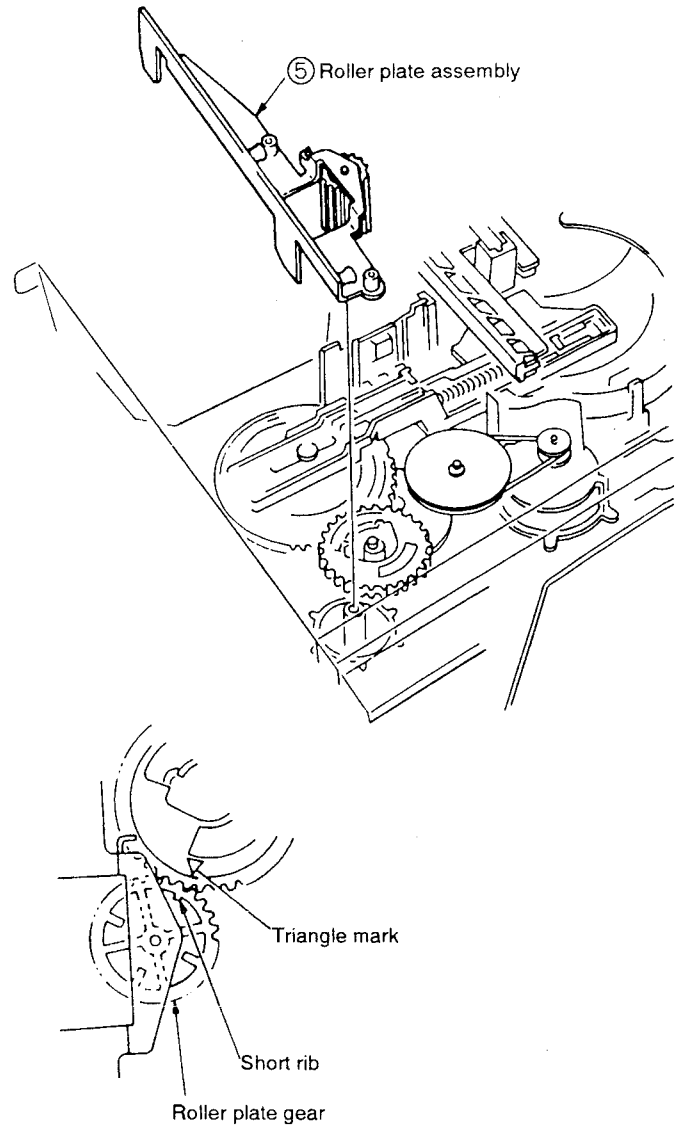

Fig. 7-14

7.9.2 Positioning the tray (Fig.7-15)

- ① Set the player with the tray open.
- ② Set the roller plate gear so that the roller plate line intersects with the mid - point of missing tooth of the roller plate gear.
(At this time, adjust the position by the method shown in Fig. 7- 15, or turn the power ON and use the SKIP (←, →) buttons in the direction of OUT tilt it stops as shown in Fig. 7- 15- 1.)

- ③ Insert the tray.
At this time, the tray can be inserted only when the first missing tooth of the tray gear is engaged with the missing tooth section of the roller plate gear, as shown in the figure. (Fig.7- 15- 1)

Tray is easier to insert by pushing slightly upwards.
(Fig.7- 15- 2)

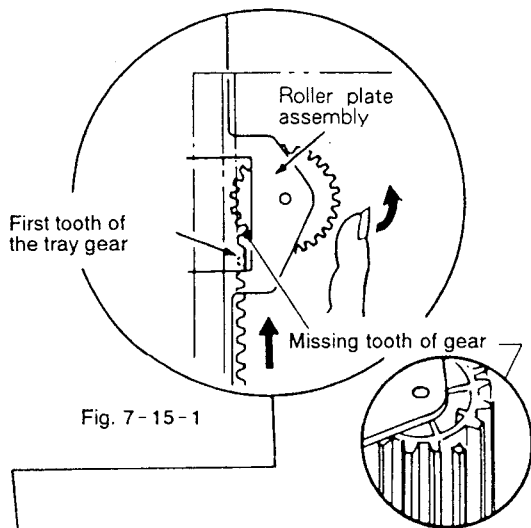

Fig. 7- 15- 1

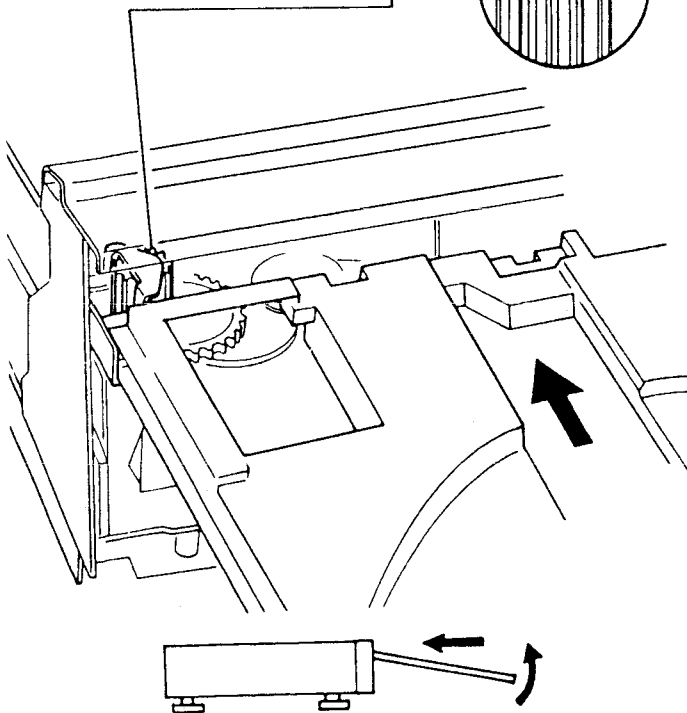

Fig. 7- 15- 2

7.9.3 Assembling the servo mechanism base assembly (Fig.7-16)

When assembling the servo mechanism base assembly, pay special attention to the following points:

- After inserting the tilt shaft in the position shown in Fig. 7-16-1 of mechanism chassis assembly, mount the servo mechanism base assembly in the direction of the arrow so that the tilt shaft does not come over the shaft holder as shown in Fig. 7-16-2.
- The thrust spring should not come over the shaft holder.
- Check that the end of the plate spring is inserted under the base.

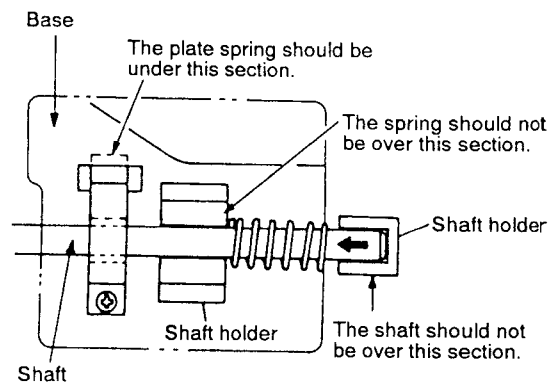

Fig 7- 16- 1

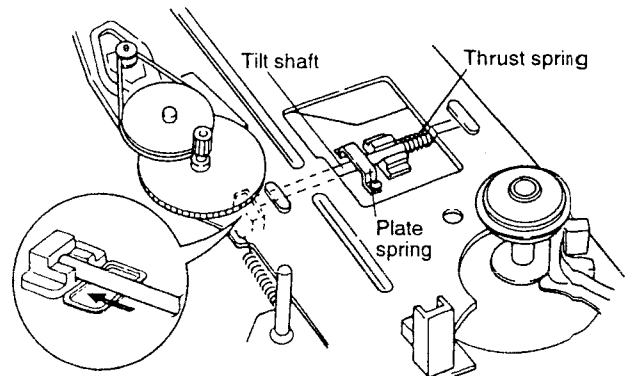

Fig. 7- 16- 2

7.9.4 Styling of the flexible cable (Fig.7-17)

- ① Bend the flexible cable of the pickup assembly by about 45° at the ▲ mark.
- ② Insert the flexible cable into the connector.
- ③ Set the flexible cable under the protruding section.
- ④ Twist the flexible cable by a half turn.
- ⑤ Insert the triangular section.
- ⑥ Further insert the flexible cable under the protruding section.

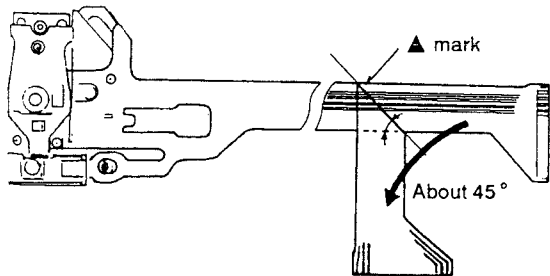

Fig. 7-17-1

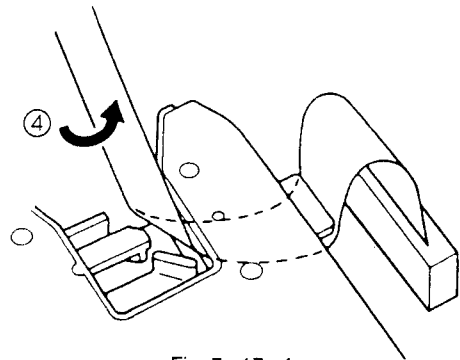

Fig. 7-17-4

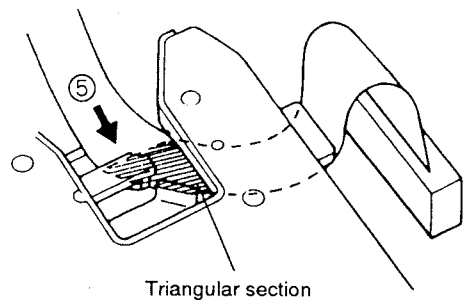

Fig. 7-17-5

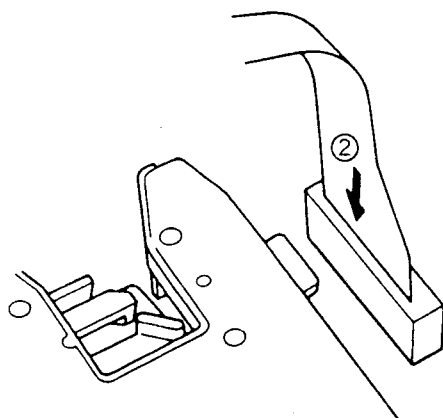

Fig. 7-17-2

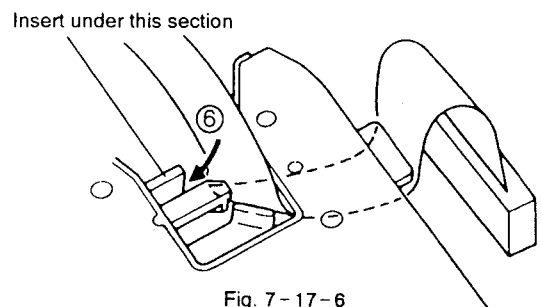

Fig. 7-17-6

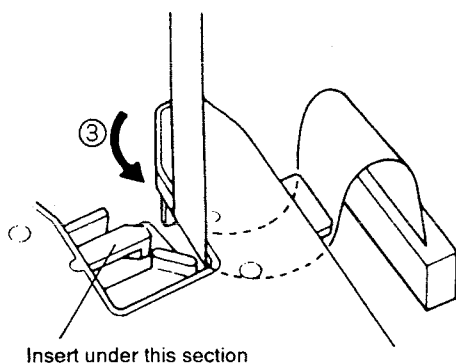
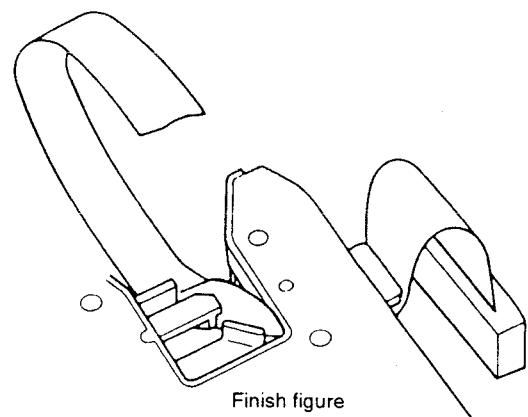

Fig. 7-17-3



Finish figure
Fig. 7-17-7

7.10 DIAGNOSING THE SYPS ASSEMBLY

(Fig.7-18)

Procedure - 1

1. Remove the screw fixing the SYPS assembly and keep the SYPS assembly apart about 3cm from the base chassis (See Fig. 7-18-1).
2. Insert a soldering iron between the SYPS assembly and base chassis, alternately desolder the lapping pins of an AC power cord, and remove the lapping pins (See Fig. 7-18-1).
3. Solder the lapping pins through the foil side of the board with the SYPS assembly raised.
The SYPS assembly can be diagnosed for component replacement through the foil side.
(See Fig. 7-18-2).

Notes:

1. Interpose cloth for check so that the SYPS assembly does not touch the chassis.
2. Remove the rear panel when you are difficult to work.

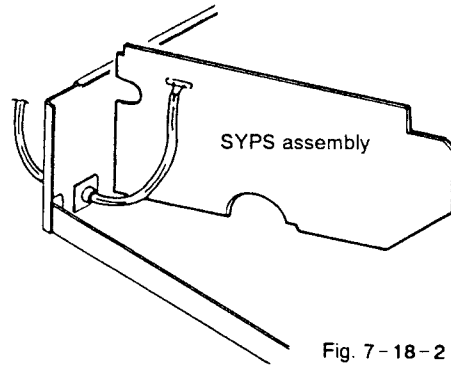
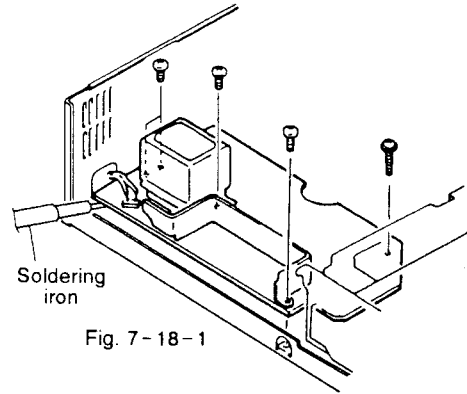

Procedure - 2

1. Insert a screwdriver into the chassis hole near a strain relief through the back of the base chassis and remove the strain relief stop ring.
2. Remove the strain relief and pull the AC power cord toward the main unit to set up the SYPS assembly.

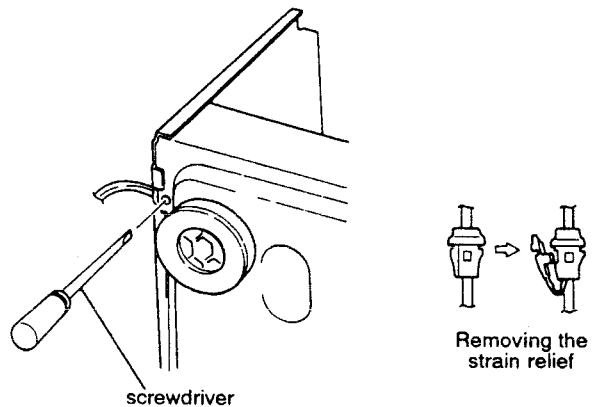

8. ADJUSTMENT

8.1 MAIN ASSEMBLY ADJUSTMENT SUMMARY

	ADJUSTMENT	P	Adjusting Point	Measurement equipment Connecting Point	Player Condition	Adjusting Specification
1	Tilt Servo Gain Adjustment	90	VR608	None	Power off	<ul style="list-style-type: none"> Making of Tilt GAIN VR position Red : Turn to Right Clear : Center Blue : Turn to Left
2	Coarse Adjustment of Grating and TRK Balance Adjustment	91	Grating/VR602	CN401 - 8 (TRK ERR)	<ul style="list-style-type: none"> Test mode #15,000 TRK servo loop open 	<ul style="list-style-type: none"> Null point → TRK error MAX Adjust VR602 so that the TRK error waveform amplitude's positive and negative level become equal.
3	Slider Shaft Horizontal Adjustment	92	Player SKIP key	CN401 - 2 (FCS RTN)	<ul style="list-style-type: none"> Test mode Tilt servo loop off TRK servo loop open #5.200 	<ul style="list-style-type: none"> Use the SKIP key to adjust to $0V \pm 20mV$.
4	Pickup Inclination Adjustment	93	Pickup Assembly TAN / TRK inclination adjustment screw	CN401 - 1 (RF)	<ul style="list-style-type: none"> Test mode #2,701 still TRK servo loop close /open Tilt servo loop open 	<ul style="list-style-type: none"> RF waveform's amplitude MAX (Pickup TAN / TRK adjustment screw) Minimized crosstalk.
5	TRKG Error Best / Crosstalk Best Adjustment	94	VR605 (TE BEST) VR606 (CT BEST)	CN401 - 8 (TRK ERR) CN401 - 1 (RF)	<ul style="list-style-type: none"> Test mode TRK servo close / open Tilt servo loop off 	<ul style="list-style-type: none"> RF MAX (VR606) TRK error MAX (VR605)
6	Focs SUM Level Adjustment	95	VR609	CN401 - 10 (FCS SUM)	<ul style="list-style-type: none"> Play mode 	<ul style="list-style-type: none"> Adjust VR 609 so that the voltage becomes 1.5VDC.
7	Tilt Sensor Inclination / Tilt Balance Adjustment	96	Tilt sensor inclination adjustment screw VR607(TILT BAL)	TV monitor Test mode screen	<ul style="list-style-type: none"> Test mode #16,200 / #115 still TRK servo loop close TRK servo loop off 	<ul style="list-style-type: none"> Set VR 607 to the center. Adjust the adjustment screw so that the tilt error display code is 6,7, or 8. Adjust VR607 so that the tilt error display becomes 7.
8	Verification and Adjustment of Spindle Motor Centering	97	Spindle motor centering adjustment screw.	CH1:CN401 - 8 (TRK ERR) CH2:CN401 - 7 (TRK SUM) (X - Y mode)	<ul style="list-style-type: none"> Test mode #25,000 / #3,000 TRK servo loop open Tilt servo loop on 	<ul style="list-style-type: none"> Adjust the centering adjustment screw so that the lissajous figures of #3,000 and #25,000 are the same.
9	Fine Adjustment of Grating and TRK Balance Adjustment	98	Grating / VR602	CH1:CN401 - 8 (TRK ERR) CH2:CN401 - 7 (TRK SUM) (X - Y mode)	<ul style="list-style-type: none"> Test mode TRK servo loop open Tilt servo loop on 	<ul style="list-style-type: none"> Minimize the Y direction of the lissajous figure. Level of the X direction of the lissajous figures are equal.
10	FCS Servo Loop Gain Adjustment	99	VR604	CH1:CN401 - 5 (FCS IN) CH2:CN401 - 4 (FCS ERR) (X - Y mode)	<ul style="list-style-type: none"> Test mode #15,000 still TRK servo loop close Tilt servo loop on 	<ul style="list-style-type: none"> Adjust VR604 so that the lissajous figure is symmetric with respect to the X and Y axes.
11	TRK Servo Loop Gain Adjustment	100	VR603	CH1:CN401 - 9 (TRK IN) CH2:CN401 - 8 (TRK ERR) (X - Y mode)	<ul style="list-style-type: none"> Test mode #15,000 still TRK servo loop close Tilt servo loop on 	<ul style="list-style-type: none"> Adjust VR603 so that the lissajous figure is symmetric with respect to the X and Y axes.
12	RF Gain Adjustment	101	VR601	CN401 - 1 (RF)	<ul style="list-style-type: none"> #15,000 still 	<ul style="list-style-type: none"> Adjust VR601 so that the RF level becomes $300mV \pm 50mV$.
13	Ref. Sub Carrier Adjustment	102	VC901	IC402 pin 8	<ul style="list-style-type: none"> STOP 	<ul style="list-style-type: none"> Adjust VC901 so that the frequency becomes 3.579545 MHz.
14	VCO Center Frequency Adjustment	103	VR481	CH1:C471 + lead wire CH2:C499 + lead wire	<ul style="list-style-type: none"> #5,100 still 	<ul style="list-style-type: none"> The center of CH1's video signal jitter is delayed by $71 \mu S$ with CH2's video signal.
15	Output Video Level Adjustment	104	VR482	VIDEO OUT terminal	<ul style="list-style-type: none"> #19,900 still 	<ul style="list-style-type: none"> Adjust the VR482 so that the voltage between the sync tip and the white peak becomes $0.71V \pm 5\%$.
16	1H Delay Video Level Adjustment	105	VR441	CH1:C443 - lead wire CH2:C445 - lead wire	<ul style="list-style-type: none"> #3,800 still 	<ul style="list-style-type: none"> The 1H delay video level becomes the same as the main line video level.
17	VPS Error Adjustment	106	VR521	TV monitor	<ul style="list-style-type: none"> #8,000 still 	<ul style="list-style-type: none"> Color irregularity on the magenta screen is minimized.

8.2 ADJUSTMENT POINTS OF THE MAIN ASSEMBLY

- VR 441 : 1 H DLY VIDEO
- VR 481 : VCO CENTER FREQ.
- VR 482 : VIDEO LEVEL
- VR 521 : VPS ERR LEVEL
- VR 601 : RF LEVEL
- VR 602 : TRKG BAL.
- VR 603 : TRKG GAIN
- VR 604 : FOCS GAIN
- VR 605 : TE MAX
- VR 606 : CT BEST
- VR 607 : TILT BAL
- VR 608 : TILT GAIN
- VR 609 : FOCS SUM

VC 901 : 14.31818 MHz

CN 401

- PIN 1 : RF
- PIN 2 : FOCS RTN
- PIN 3 : TRKG RTN
- PIN 4 : FOCS ERR
- PIN 5 : FOCS IN
- PIN 6 : GND
- PIN 7 : TRKG SUM
- PIN 8 : TRKG ERR
- PIN 9 : TRKG IN
- PIN 10 : FOCS SUM

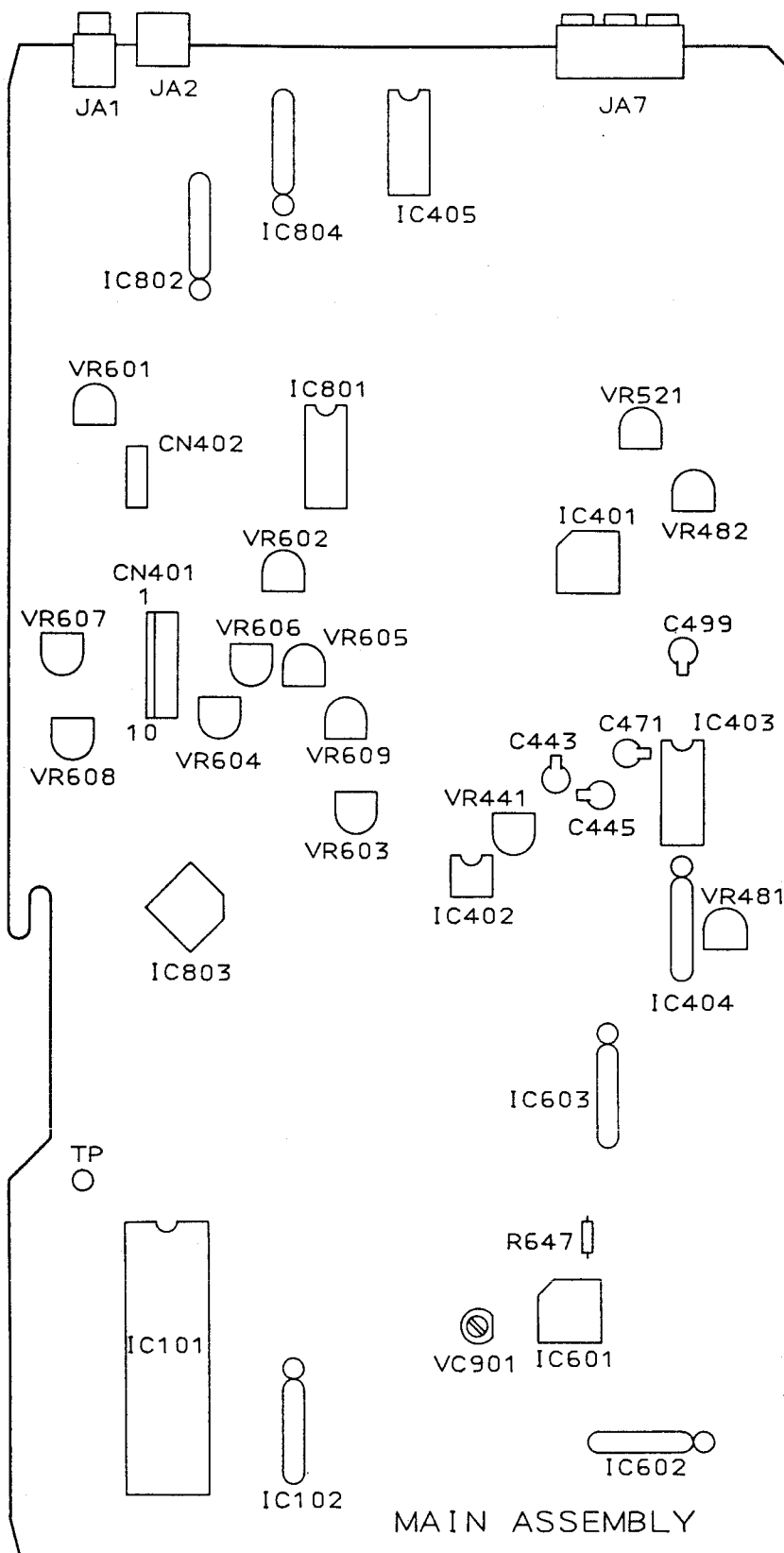

MAIN ASSEMBLY

8.3 TEST MODE

8.3.1 TEST MODE

The player has a test mode function which allows the servicer to check the player's status on the TV screen by executing the respective key operation.

Also, since the TRK servo opens and closes easily, the test mode is especially useful for mechanical adjustments.

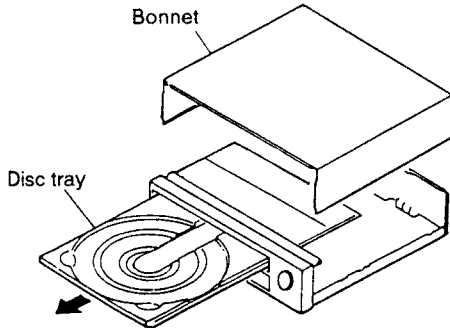

8.3.2 TEST MODE INITIATION

[Procedure]

1. Remove the bonnet and disc tray.
2. Connect the TP101 (TEST) in the MAIN assembly to GND.
3. Turn on the power switch.
4. Disconnect the TP101 from GND.

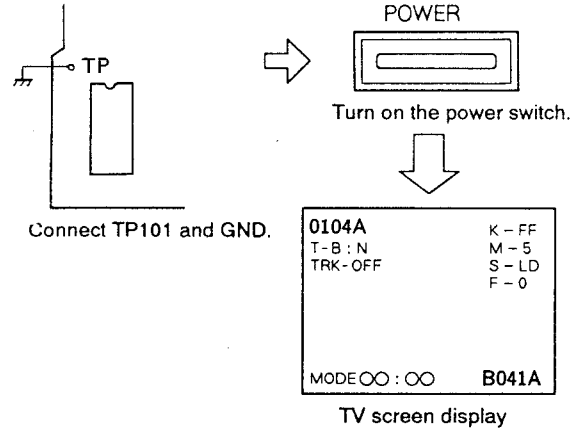

8.3.3 TEST MODE CANCELLATION

Turn off the power switch.

Note : Before cancelling the test mode, be sure to rotation of disc is stopped.

8.3.4 PLAYER OPERATION IN THE TEST MODE

Operate the player by selecting a test mode function with the keys on the player or on the remote control unit.

● CD PLAYBACK

- ① Place the CD disc on the turn table.
(Clamper is already lifted up.)

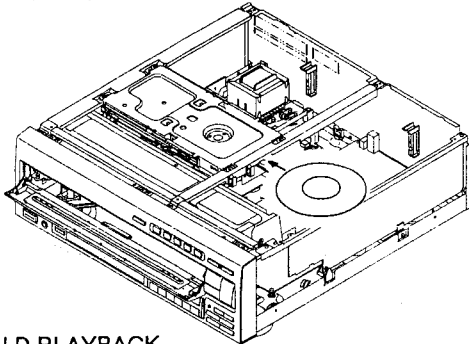

- ② Press the ◀◀ or ▶▶ key to appear "S-CD" on the TV screen display.

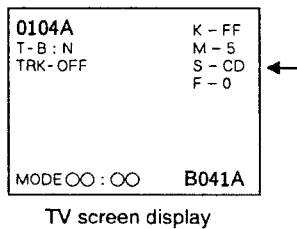

- ③ Clamp the disc by pressing the PLAY (▶) key once. Then, press the PLAY (▶) key twice, disc will be normal playbacked.

● LD PLAYBACK

- ① Place the LD disc on the turn table.
(Clamper is already lifted up.)

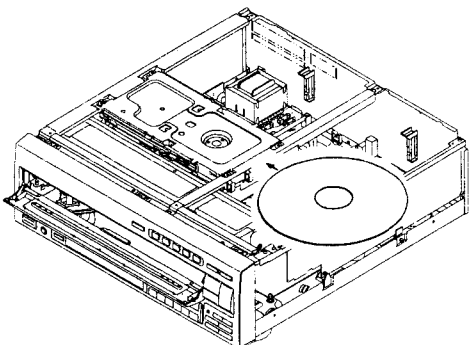

- ② Press the ◀◀ or ▶▶ key to appear "S-LD" on the TV screen display.

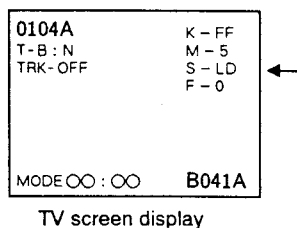

- ③ Clamp the disc by pressing the PLAY (▶) key once. Then, press the PLAY (▶) key twice, disc will be normal playbacked.

Function	Player Status	Key Operation	Remarks
Open Tray	STOP mode	▲	
Close Tray	Tray open	▲	
Stop	PLAY mode	■	
Play	Disc placement and tray closed.	▶	<ul style="list-style-type: none"> • Start play with the TRK servo open. • Start play with tilt neutral. • The disc type (LD/CD/CDV) is determined when playback starts at the SLDR position during start play.
TRK Servo Open/Close	PLAY mode	▶	<ul style="list-style-type: none"> • Each time the PLAY button (▶) is pressed, the TRK servo will open or close alternately.
Still	PLAY mode TRK servo closed.	(Remote control unit key)	<ul style="list-style-type: none"> • Each time the STILL button () is pressed, the player will switch between the PLAY and STILL modes alternately.
SLDR REV SCAN	PLAY mode	◀◀	<ul style="list-style-type: none"> • Counterclockwise • With the TRK servo open, the pickup can be damaged if the SLD moves further inward than the lead-in area on the disc. Do not allow the SLD to move further inward than the lead-in area .
SLDR FWD SCAN	PLAY mode	▶▶	<ul style="list-style-type: none"> • Clockwise • With the TRK servo open, the pickup can be damaged if the SLD moves further outward than the lead-in area on the disc. Do not allow the SLD to move further outward than the lead-in area.
TILT Neutral	POWER switch ON	(Main unit key)	
TILT Servo ON	PLAY mode	RANDOM PLAY	
TILT Minus TILT Servo OFF	PLAY mode	◀◀	<ul style="list-style-type: none"> • Press and hold down the keys.
TILT Plus TILT Servo OFF	PLAY mode	▶▶	<ul style="list-style-type: none"> • Press and hold down the keys.
Screen Display ON/OFF	POWER switch ON	PGM key	
Frame search	PLAY mode	+10 key ↓ 0-9 key ↓ ▶	<ul style="list-style-type: none"> • In the PLAY mode, press the +10 key. (The player will standby for the frame No. entry.) • Use the numeric keys(0 - 9) to enter the frame No.. Then press the player's PLAY key to search. • After the search is completed, the player will return to the previous mode before the search was performed.
Loading Motor Rotation Clockwise Counterclockwise	Tray open	▶▶ ◀◀	<ul style="list-style-type: none"> • FWD:Unloading • REV :Loading
FOCS OFFSET (CT BEST) VR606 Check	PLAY mode (TRK servo OPEN)	(Remote control unit) MULTI-SPEED FWD → F-1 REV → F-0 (Player) HILITE INTRO SCAN	<ul style="list-style-type: none"> • For checking VR604 <p>F-0 : Normal mode</p> <ul style="list-style-type: none"> •When closing the TRK servo, VR606 (CT BEST) is effectived. •When opening the TRK servo, VR605 (TE MAX) is effectived. <p>F-1 : When opening the TRK servo, VR606 (CT BEST) is also effectived.</p>

● **Special Test Mode Operation of CLD-M 90**

① **Aging mode**

[Procedure]

Press the HILITE/INTRO key with the tray opened.

[Operation]

1. The tray is closed and Disc 1 is inserted. (Refer to page 109.)
2. Clamp Disc 1.
3. Disc 1 is returned to the original position on the tray
4. Operations 2 - 3 are also performed for Discs 2 - 5. (This chain of operation is performed in one cycle.)
5. Ten cycles are performed all together.

Note :

- If the STOP key is pressed during operation, the Disc is returned and stopped.
- If the Disc is not clamped, the stand-by function will be activated and the place of the FL display will become 1.

— FL display(example) —

09 00010-----9 cycles OK. Disc 4 is not clamped during the 10 th cycle.

10 00000-----Aging is normally completed.

② **Disc replacement**

[Procedure and operation]

1. Set SLDR to CD position.
2. When pressing the Disc No. key, SPDL begins to rotate after the selected Disc has been moved to the center.
3. The Disc is returned to the disc tray when the STOP key is pressed.

8.3.5 TV SCREEN AND LED DISPLAYS IN THE TEST MODE

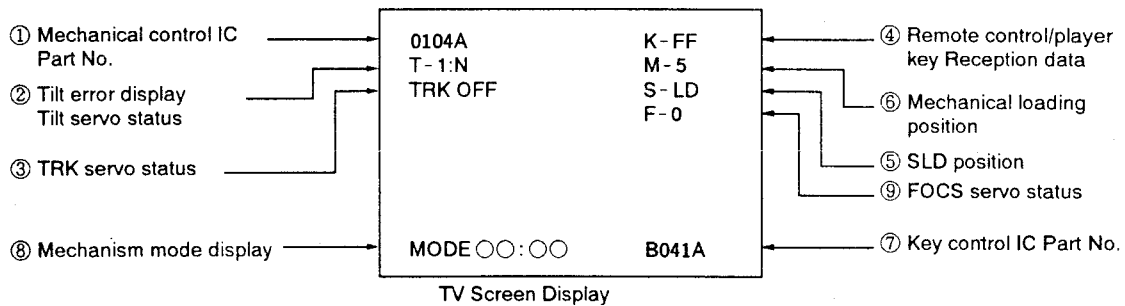

① **The Mechanical Control IC (MAIN assembly) Part No. will be Displayed.**

0104 A

② **Tilt Servo Status / Tilt Error Display**

T-○:○○

- Tilt servo status : N...Tilt neutral
- ON...Tilt servo ON
- OFF...Tilt servo OFF
- Tilt error display: 0 Tilt -
- ↓ Tilt neutral
- F Tilt +

③ TRK Servo Status

TV screen display

TRK-○○○○

- ↑ ON...TRK servo close
- OFF...TRK servo open

④ Remote Control / Player Key Reception Data

TV screen display

K-○○

↑ See table below

Code	Function	Code	Function	Code	Function	Code	Function
00	0	20		40	(CHAP / TRK)	60	
01	1	21		41	(FRAM / TIM)	61	
02	2	22		42	(SEARCH)	62	
03	3	23		43	DISPLAY	63	
04	4	24		44	REPEAT B	64	
05	5	25		45	CLEAR	65	
06	6	26		46	SPEED -	66	
07	7	27		47	SPEED +	67	
08	8	28		48	REPEAT A	68	
09	9	29		49	(2 / R)	69	
0A		2A		4A	(STEREO)	6A	
0B		2B		4B	(1 / L)	6B	
0C	DGT / ANL	2C		4C	PROGRAM	6C	
0D		2D		4D		6D	PLAY / PAUSE
0E	CX	2E		4E		6E	STOP
0F		2F		4F		6F	OPEN / CLOSE
10	(F-SCAN)	30	(DISC TGL)	50	R-STEP	70	
11	(R-SCAN)	31	DISC 1	51		71	DIRECT CD
12		32	DISC 2	52	F-SKIP	72	
13	CHAP / FRME	33	DISC 3	53	R-SKIP	73	
14		34	DISC 4	54	R-STEP	74	ADLC
15		35	DISC 5	55	R-MULT	75	
16	STOP / OPEN	36		56		76	
17	PLAY/SERCH	37		57		77	
18	PAUSE	38		58	F-MULT	78	
19		39		59		79	
1A	(POW ON)	3A		5A	HILIT / INTR	7A	
1B	(POW OFF)	3B		5B		7B	
1C	POW ON/OFF	3C		5C		7C	
1D	EDIT	3D		5D		7D	
1E	AUDIO	3E		5E	RNDM (TEST)	7E	
1F	+10	3F		5F	(ESC)	7F	

⑤ SLD Position

TV screen display

S-○○○○

- ↑ IN ... CD inside SW ON
- CD ... CD active area
- CDV ... CDV active area
- LD ... LD active area

⑥ Mechanical Loading Position

TV screen display

M-○

- ↑ 0 ... Tray open
- 1 ... Loading
- 2 ... Standby
- 3 ... Clamped
- 5 ... Tilt minus
- 6 ... Tilt neutral (one side)
- 7 ... Tilt plus
- 8 ... Tilt limit
- 9 ... B side clamped (two sides)

⑦ Focus Offset VR Status

TV screen display

F-○

- ↑ 0 ... Normal mode
 - When closing the TRK servo, VR606 (CT BEST) is effectived.
 - When opening the TRK servo, VR605 (TE MAX) is effectived.
- 1 ... When opening the TRK servo, VR606 (CT BEST) is also effectived.

2. COARSE ADJUSTMENT OF GRATING AND TRK BALANCE

Mechanical Adjustment

- Purpose: Adjustment of the grating angle to enable disc playback and trick playback.
- When not properly adjusted: The disc cannot be played back. Track skipping occurs.

- Measuring instruments and jigs:
- Measuring point:
- Test disc and player mode
- Positions to be adjusted

- TV monitor ● Small screwdriver ● Oscilloscope
- CN401 - 8 (TRK ERR) and GND
- 8-inch LD test disc (GGV1003)
- Test Mode (Disc playback, TRK servo open, Tilt servo OFF)
- Pickup assembly grating
- VR602 (TRK BAL).

Connection diagram

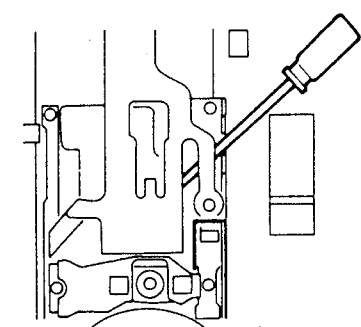

(Top view)
Screwdriver inserting direction

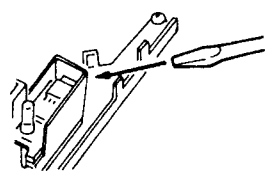

Insert the screwdriver to the slot horizontally for the base.

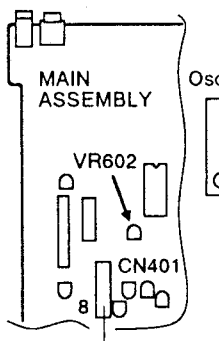
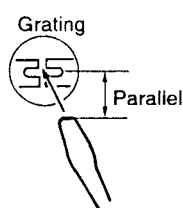

Oscilloscope range
X:50mV / div
Y:5mS / div
DC input

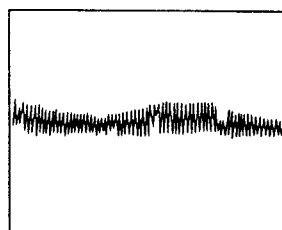

Fig.1 Null Point

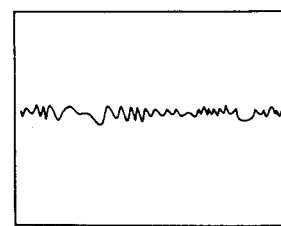

Fig.2 This is not the null point.

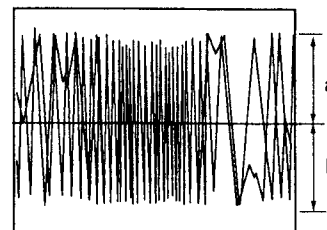

Fig.3 Maximum TRK error.

The positive and negative levels are equal.

Adjustment Procedure

Coarse grating adjustment

1. Insert the test disc and press the PLAY key.
2. Search for frame #15,000 or thereabouts.
3. Open the TRK servo.
4. Connect CN401 - 8 to the oscilloscope and observe the waveform.
5. Slide the tip of a small screwdriver through the guide and insert it horizontally into the grating adjustment slit. Adjust grating angle so that the waveform becomes small a its envelope is smooth. (This point is called null point.) (See Fig. 1 and Fig. 2.)
6. Turn the screwdriver counterclockwise until the TRK waveform's amplitude reaches the first maximum from the null point.(See Fig. 3.)

TRK balance adjustment

1. Adjust VR602 so that the TRK error waveform amplitude's positive and negative level become equal. (See Fig.3.)
2. Close the TRK servo and check if the image on the TV screen is normal.

3. SLIDER SHFT HORIZONTAL ADJUSTMENT

Mechanical Adjustment

- Purpose: Setting the slider shaft horizontally to enable the pickup to move over the disc horizontally.
- When not properly adjusted: With a warped disc, the FCS servo does not function at the inner or outer periphery.

- Measuring instruments and jigs:
- Measuring point:
- Test disc and player mode
- Positions to be adjusted

- Oscilloscope ● Low-pass filter (47k Ω + 1 μ F)
- CN401 - 2 (FCS RTN) and GND
- 8- inch LD test disc GGV1003
- Test mode (#5,200 still, TRK servo open, Tilt servo OFF)
- Player SKIP key (In the test mode)

Connection diagram

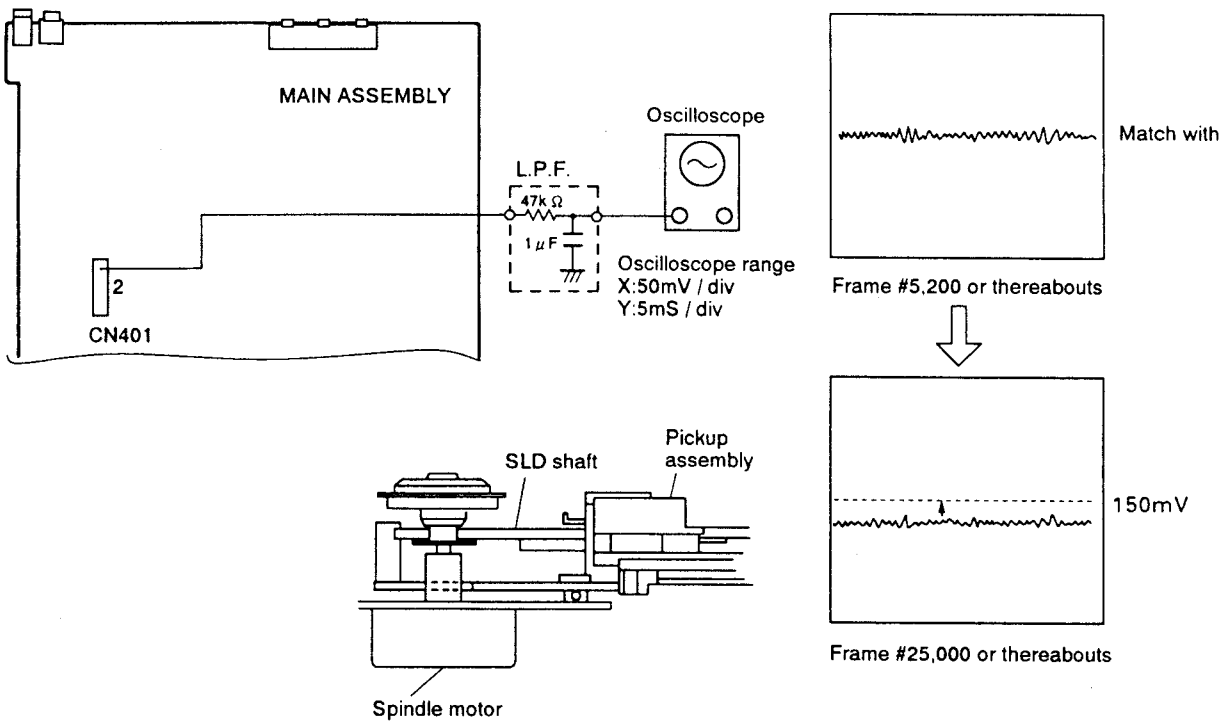

Adjustment Procedure

1. Use the SCAN key to send the slider to frame #5,200 or thereabouts (tilt fulcrum) on the test disc. Open the TRK servo.
2. Connect the oscilloscope to CN401 - 2 through L.P.F. and match the center of the waveform with the oscilloscope's GND.
3. Search for frame #25,000 and use the SKIP key to adjust the center of the waveform to 150mV \pm 20mV.

Note: This adjustment is critical in that it will affect the adjustments following.

Note: Regarding the test mode, see page 85.

7. TILT SENSOR INCLINATION / TILT BALANCE ADJUSTMENT

Mechanical Adjustment

- Purpose: Adjustment of the tilt sensor's inclination to direct the tilt sensor's LED vertically with respect to the disc. Also, compensation for the sensitivity difference between the two sensors.
- When not properly adjusted: Crosstalk will be generated.

- | | |
|--|---|
| <ul style="list-style-type: none"> ● Measuring instruments and jigs: ● Measuring point: ● Test disc and player mode ● Positions to be adjusted | <ul style="list-style-type: none"> ● TV monitor ● Small Phillips screwdriver ● Player's VIDEO OUT terminal ● 8-inch LD test disc (GGV1003) ● Test Mode (#16,200 still, TRK servo closed, Tilt servo OFF) ● Tilt sensor inclination adjustment screw ● VR607 (TILT BAL). |
|--|---|

Connection diagram

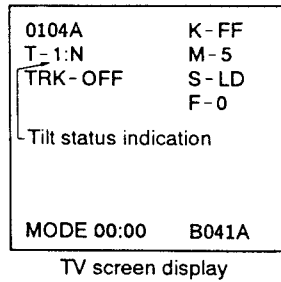
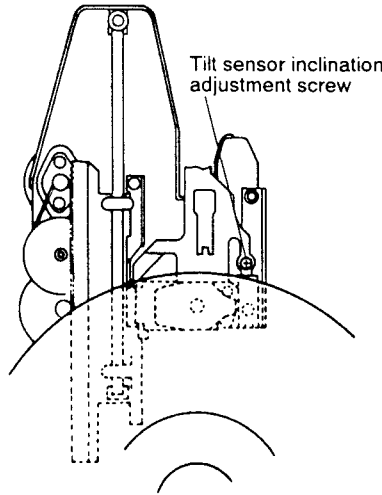
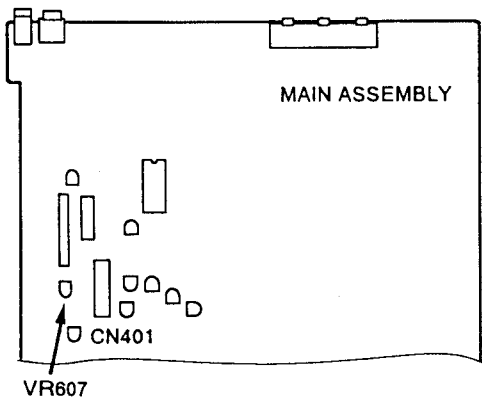

Note: This display indicates the tilt error display's location. Other displays may differ slightly from the actual.

Adjustment Procedure

1. Search for frame #16,200 on the test disc.
2. Set VR607 to the mechanical center.
3. Adjust the tilt sensor inclination adjustment screw so that the tilt status display code is 6, 7, or 8 on the TV monitor.
Note : Turn the tilt sensor inclination adjustment screw clockwise more than 1/4 turn to complete the adjustment.
4. Search for frame #115.
5. Adjust VR607 so that the tilt error display becomes 7.

6. FOCS SUM LEVEL ADJUSTMENT

Mechanical Adjustment

- Purpose: To set the sum level (FOCS A+B) of B1 – B4 to the optimum value for activating the FOCS servo.
- When not properly adjusted: Crosstalk will be generated.

- | | |
|--|--|
| <ul style="list-style-type: none"> • Measuring instruments and jigs: • Measuring point: • Test disc and player mode • Positions to be adjusted | <ul style="list-style-type: none"> • TV monitor • Oscilloscope • CN401 - 10 • 8-inch LD test disc (GGV1003) • Normal play mode • VR609 |
|--|--|

Connection diagram

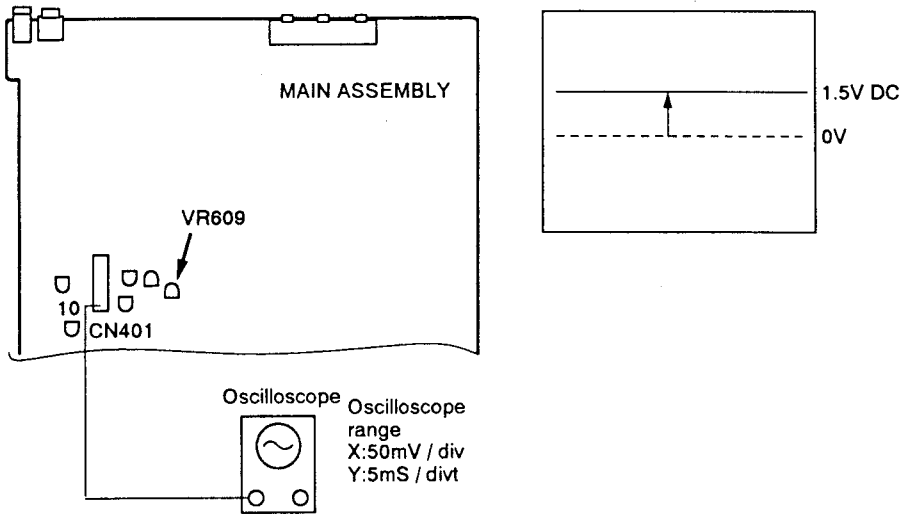

Adjustment Procedure

Note : Perform this adjustment after perform the "5. TRKG Error MAX / Crosstalk Best Adjustment".

1. Connect the oscilloscope to CN401 - 10.
2. Adjust VR609 so that the voltage becomes 1.5V DC.

5. TRKG ERROR MAX / CROSTALK BEST ADJUSTMENT

Mechanical Adjustment

- Purpose: To set the FOCS servo to the optimum state when playing the normal playback and track jump (search).
- When not properly adjusted: Crosstalk will be generated.

- Measuring instruments and jigs:
- Measuring point:
- Test disc and player mode
- Positions to be adjusted

- TV monitor ● Oscilloscope
- CN401 - 1 (RF) ● CN401 - 8 (TRK ERR) ● Player's VIDEO OUT terminal
- 8 - inch LD test disc (GGV1003)
- Test Mode (TRK servo close / open, Tilt servo OFF)
- VR605 (TE MAX) ● VR606 (CT BEST)

Connection diagram

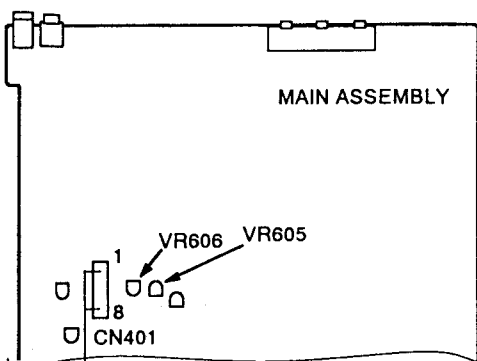

0104A K-FF
 T-B:N M-5
 TRK-OFF S-LD
 F-0 ←

MODE 00:00 B041A

Screen display of test mode

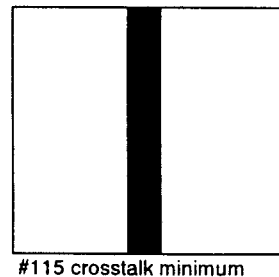
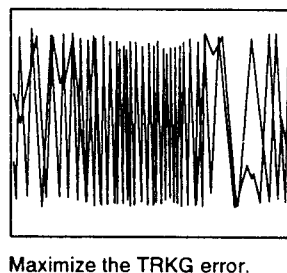
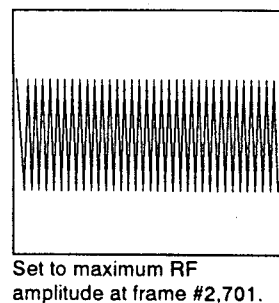

Adjustment Procedure

Note : Perform this adjustment when there is still noticeable crosstalk on the TV screen in section "4. Pickup Inclination Adjustment".

1. Connect the oscilloscope to CN401 - 8.
2. Open the TRK servo .
3. Confirm that the test mode screen display is F-0.
 If not, set the MULTI - SPEED REV button of the remote control unit to F-0.
4. Adjust VR605 so that the amplitude of the TRKG error waveform becomes maximum.
5. Close the TRKG servo.

6. Connect the oscilloscope to CN401 - 1 .
7. Press the MULTI - SPEED FWD button of the remote control unit to display "F - 1" on the TV screen.
8. Search frame #2,701 and adjust VR606 so that the amplitude of the RF waveform becomes maximum.
9. Confirm that the crosstalk on the TV screen becomes minimum at frame #115.

Note : After adjustment is complete, be sure to perform "6. FOCS SUM Level Adjustment".

4. PICKUP INCLINATION ADJUSTMENT

Mechanical Adjustment

- Purpose: Adjustment of the pickup inclination to direct the laser beam vertically with respect to the disc.
- When not properly adjusted: Crosstalk will be generated.

- | | |
|--|--|
| <ul style="list-style-type: none"> • Measuring instruments and jigs: • Measuring point: • Test disc and player mode • Positions to be adjusted | <ul style="list-style-type: none"> • TV monitor • Oscilloscope • CN401 - 1 (RF) • 8-inch LD test disc (GGV1003) • Test Mode (#2,701 still (Black screen)) • Pickup assembly TRK / Tangential direction inclination adjustment screws |
|--|--|

Connection diagram

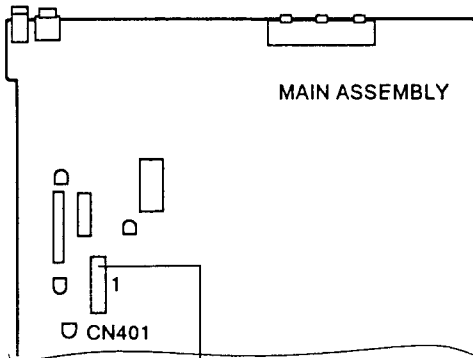

Oscilloscope
 Oscilloscope range
 X:10mV / div
 Y:5mS / div
 AC input

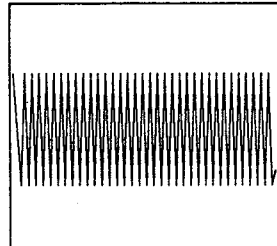

Set to maximum RF

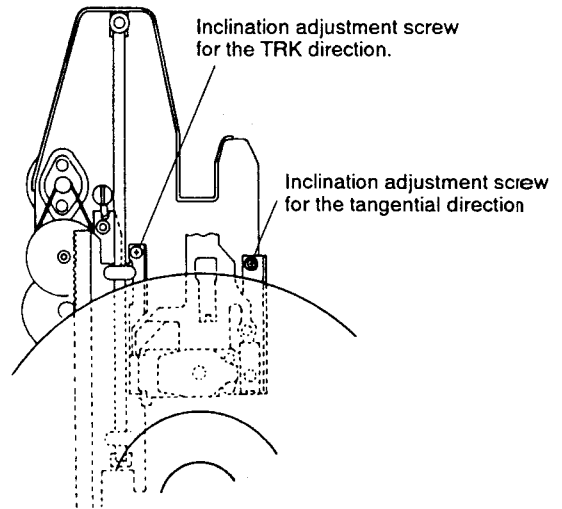

Adjustment Procedure

1. Connect the oscilloscope to CN401 - 1.
2. Search for #2,701 and observe the RF waveform.
3. Adjust the pickup's TRK / Tangential direction inclination adjustment screw to maximize the waveform's amplitude.
4. Look at the TV screen and make sure there is no crosstalk.

Note : If there is crosstalk on the TV screen even when the RF level is at the maximum, perform next steps .

8.4 ADJUSTMENTS

8.4.1 Required Instruments

- Small screwdriver (7 cm shaft)
- Small Phillips screwdriver (15 cm shaft)
- Low - pass filter (47k ohms+1 μ F / BP)
- Dual - trace oscilloscope (with delay)
- AF oscillator
- Frequency counter
- LD test disc (GGV1003)
- 8 - inch LDD disc
- CDV disc
- Short clip
- TV monitor
- Resistor (100k ohms, 330k ohms)
- Capacitor (0.01 μ F)
- Remote control unit
- 2mm hexagonal wrench

8.4.2 Adjustment Preparation and Notes

1. Player Preparation

Before perform the adjustment, remove the bonnet and the disc tray. Then place the player horizontally on a flat surface.

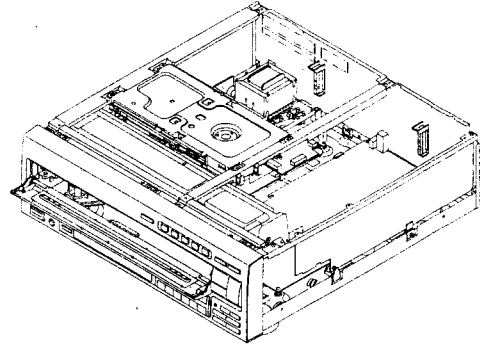

2. Disc Insertion

Insert the disc from the rear of the player. Place it securely on the turntable. When the PLAY key is pressed, the clamper will go down and secure the disc. Playback will then begin.

3. Use All the Oscilloscope's Probes at 10: 1.

4. Only the MAIN Assembly Needs to be Adjusted.

Unless noted otherwise, all adjustment items and measuring instrument connections will be for the parts in the MAIN assembly.

5. Required adjustment after Replacement of major parts.

Adjustments	Replacements				
	Pickup	Actuator	Pre-pickup	Spindle motor	Tilt sensor
1. Tilt Sensor Adjustment	⊙				⊙
2. Coarse Grating Adjustment / TRK Balance Adjustment	⊙	⊙	⊙		
3. Slider Shaft Horizontal Adjustment	⊙	⊙	⊙	○	⊙
4. Pickup Inclination Adjustment	⊙	⊙	⊙	○	○
5. TRKG Error Best / Crosstalk Best Adjustment	⊙	⊙	⊙	○	○
6. FOCUS SUM Level Adjustment	⊙	⊙	⊙	○	○
7. Tilt Sensor Inclination / Tilt Balance Adjustment	⊙	⊙	⊙	○	⊙
8. Spindle Motor Shaft Centering and Adjustment	⊙	⊙	⊙	⊙	
9. Fine Grating Adjustment / TRK Balance Adjustment	⊙	⊙	⊙		
10. FCS Servo Loop Gain Adjustment	⊙	⊙	⊙		
11. TRKG Servo Loop Gain Adjustment	⊙	⊙	⊙		
12. RF Gain Adjustment	⊙	⊙	⊙		

Note: Adjustments indicated by a ○ are made only when there is crosstalk.

8.4.3 MECHANICAL ADJUSTMENTS

1. TILT SERVO GAIN ADJUSTMENT

Mechanical Adjustment

- Purpose: Adjustment of the tilt servo's gain according to the tilt sensor's sensitivity rank.
- When not properly adjusted: Increased tilt servo hunting and increased crosstalk.

- Measuring instruments and jigs:
 - Measuring point:
 - Test disc and player mode
 - Positions to be adjusted
- Small screwdriver
 - VR608

Connection diagram

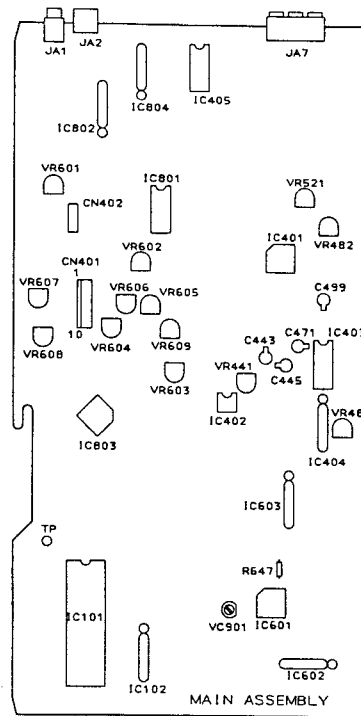
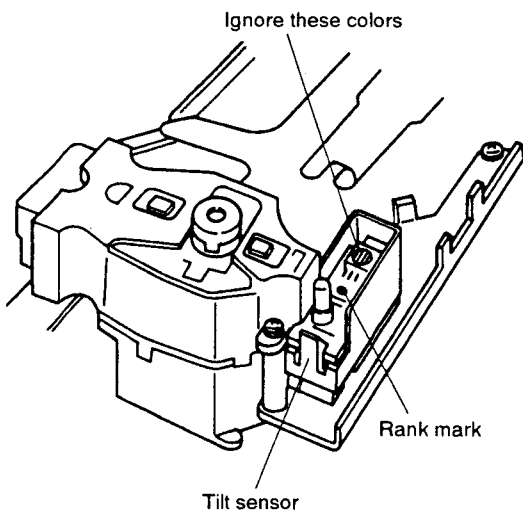

Adjustment Procedure

1. Use a screwdriver to adjust the angle of VR608 on the MAIN assembly according to the rank indicator's color.

Rank	Color	VR Angle
A	Red	Clockwise all the way
B	Clear	Mechanical center
C	Blue	Counterclockwise all the way

8. VERIFICATION AND ADJUSTMENT OF SPINDLE MOTOR CENTERING

Mechanical Adjustment

- Purpose: Adjustment of the mechanical assembly position to set the spindle motor over the center of the laser beam path when the pickup assembly moves toward the inner or outer periphery of the disc.
- When not properly adjusted: There is track skipping and the search time is long.

- | | |
|--|--|
| <ul style="list-style-type: none"> • Measuring instruments and jigs: • Measuring point: • Test disc and player mode • Positions to be adjusted | <ul style="list-style-type: none"> • Oscilloscope • Small screwdriver • L.P.F. (0.01 μF + 1k Ω), (0.0027 μF) • 2mm Hexagonal wrench • CH1 : CN401 - 8 (TRK ERR), CH2 : CN401 - 7 (TRK SUM) • 8 - inch LD test disc (GGV1003) • Test Mode (#25,000 still, #3,000 still, TRK servo open, TILT servo ON) • Spindle motor centering adjustment lever |
|--|--|

Connection diagram

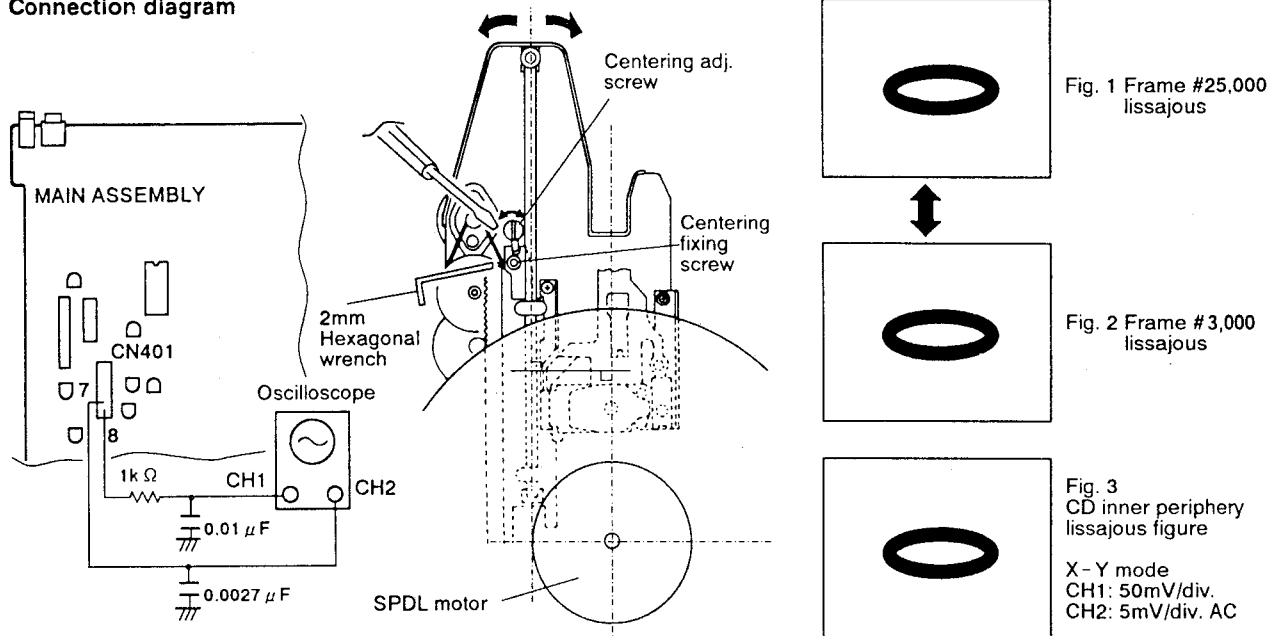

Adjustment Procedure

Note: Adjust the position of the slider shaft against the center line of the SPDL motor in this adjustment.

1. Set the oscilloscope to the X - Y mode and connect CH 1 (X input) and CH 2 (Y input) to CN401 - 8 and CN401 - 7 respectively.
2. Search for frame #25,000 on the test disc and look at the lissajous figure.
3. Search for frame #3,000 and check if the bulge of the lissajous figure is the same as that of frame #25,000's lissajous figure.
Note : If the bulge of the lissajous waveform in step 3 differs for the inner and outer peripheries, do steps 4 to 6 .
4. Search for frame #25,000 and #3,000 alternately. Loosen a centering fixing screw and adjust the spindle motor centering adjustment screw so that the bulge of the lissajous figures become identical.

5. Change to a compact disc and playback the inner periphery. Check if the lissajous figure is the same as the one shown in Fig. 3.
6. If the compact disc's inner periphery lissajous figure differs from the one shown in Fig. 3, repeat steps 4 to 5.
7. Fix the centering fixing screw.

9. FINE ADJUSTMENT OF GRATING AND TRK BALANCE ADJUSTMENT

Mechanical Adjustment

- Purpose: Fine adjustment of the grating to direct the two TRK servo laser beams at the disc at the optimum position over the track.
- When not properly adjusted: There is track skipping.

- | | |
|--|--|
| <ul style="list-style-type: none"> ● Measuring instruments and jigs: ● Measuring point: ● Test disc and player mode ● Positions to be adjusted | <ul style="list-style-type: none"> ● Oscilloscope ● Small screwdriver ● L.P.F. (0.01 μF + 1k Ω), (0.0027 μF) ● CH1 (X) : CN401 - 8 (TRK ERR), CH2 (Y) : CN401 - 7 (TRK SUM) ● 8 - inch LD test disc (GGV1003) ● Test Mode (Play mode, TRK servo loop open, TILT servo ON) ● Grating slit in the pickup assembly ● VR602 |
|--|--|

Connection diagram

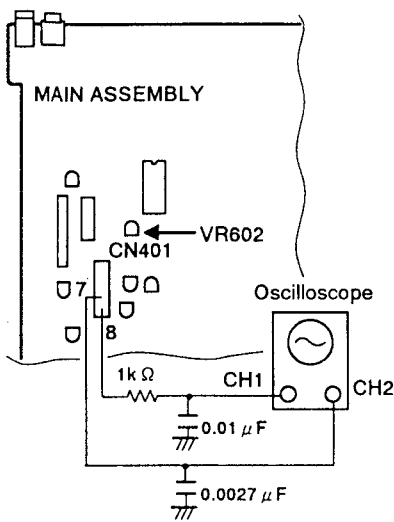

Set the probe to $\times 1$ only for Y.

- Oscilloscope range:
CH1 (X): 50mV/div.
CH2 (Y): 5mV/div. X-Y mode

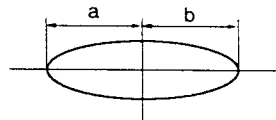

Frame #3,000
Lissajous figure
Y direction minimum, a=b.

Adjustment Procedure

1. Playback the test disc at frame #3,000 (inner periphery) or thereabouts.
2. Set the oscilloscope to the X-Y mode, and connect CN401 - 8 (TRK ERR) and CN401 - 7 (TRK SUM) to the X input and the Y input respectively. Then observe the lissajous figure.
3. Insert the small screwdriver tip into the grating adjustment slit. Fine adjust the grating to minimize the Y direction of the lissajous figure. (Refer to adjustment diagram on page 76.)
4. Check if "a" equals "b" for the lissajous figure. If "a" is not equal to "b", adjust VR602 (TRK BAL).
5. Close the TRK servo loop and check if the image on the TV screen is normal.

10. FCS SERVO LOOP GAIN ADJUSTMENT

Mechanical Adjustment

- Purpose: Setting the FCS servo's loop gain to the optimum setting.
- When not properly adjusted: Playability is poor.

- | | |
|--|---|
| <ul style="list-style-type: none"> • Measuring instruments and jigs: • Measuring point: • Test disc and player mode • Positions to be adjusted | <ul style="list-style-type: none"> • Oscilloscope • AF oscillator (1.7kHz / 10Vp-p) • Resistor (47k Ω) • CH1 (X) : CN401 - 5 (FCS IN), CH2 (Y) : CN401 - 4 (FCS ERR) • 8 - inch LD test disc (GGV1003) • Test Mode (Still mode, TRK servo loop close, TILT servo ON) • VR604 |
|--|---|

Connection diagram

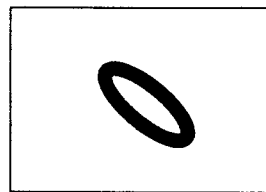
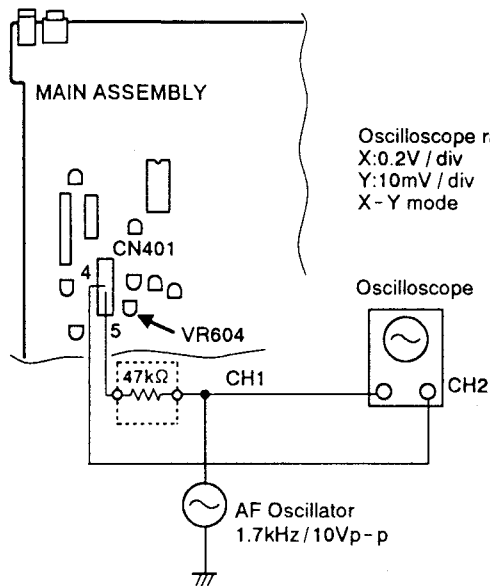

Fig. 1
Inadequate adjustment

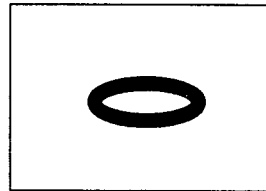

Fig. 2
After adjustment

Adjustment Procedure

1. Search for frame #15,000 on the test disc.
2. Connect the oscilloscope to CN401 - 4 and CN401 - 5 as shown above.
3. Set the oscilloscope to the X - Y mode and observe the lissajous figure.
4. Adjust VR604 so that the lissajous figure is symmetric with respect to the X and Y axes. (See Fig. 1 and 2.)

11. TRK SERVO LOOP ADJUSTMENT

Mechanical Adjustment

- Purpose: Optimum setting of the TRK servo's loop gain.
- When not properly adjusted: Playability is poor.

- Measuring instruments and jigs:
- Measuring point:
- Test disc and player mode
- Positions to be adjusted

- Oscilloscope ● AF oscillator (3.0kHz / 10Vp-p) ● Resistor (47k Ω)
- CH1 (X) : CN401-9 (TRK IN), CH2 (Y) : CN401-8 (TRK ERR)
- 8-inch LD test disc (GGV1003)
- Test Mode (Still mode at #15,000 (Black screen), TRK servo closed, TILT servo ON)
- VR603

Connection diagram

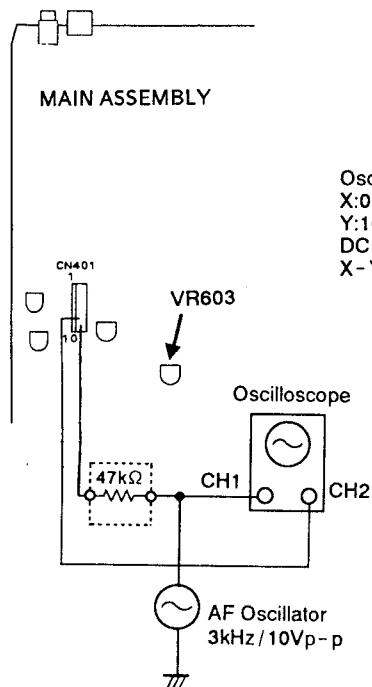

Oscilloscope range
 X:0.2V / div
 Y:10mV / div
 DC input
 X-Y mode

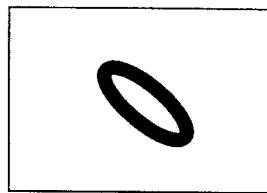

Fig. 1
Inadequate adjustment

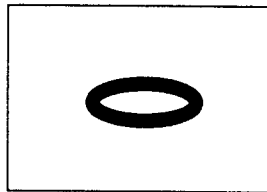

Fig. 2
After adjustment

Adjustment Procedure

1. Search for frame #15,000 on the test disc.
2. Connect the oscilloscope to CN401-9 (TRK IN) and CN401-8 (TRK ERR) as shown in the diagram below.
3. Set the oscilloscope to the X-Y mode and observe the lissajous figure.
4. Adjust VR603 to make the lissajous figure symmetrical with respect to the X and Y axes. (See Fig. 1 and 2.)

Note : If the waveform is not observable, either change the 47k Ω resistor to 33k Ω or increase the oscillator's output.

12. RF GAIN ADJUSTMENT

Mechanical Adjustment

- Purpose: Optimum of the RF signal's amplitude.
- When not properly adjusted: There is prominent dropout. Scan and search operations are unstable.

- | | |
|--|---|
| <ul style="list-style-type: none"> • Measuring instruments and jigs: • Measuring point: • Test disc and player mode • Positions to be adjusted | <ul style="list-style-type: none"> • Oscilloscope • CH1 : CN401 - 1 (RF) • 8-inch LD test disc (GGV1003) • Test Mode (Still mode, TRK servo loop close, TILT servo ON) • VR601 |
|--|---|

Connection diagram

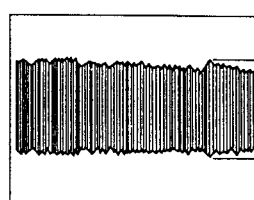
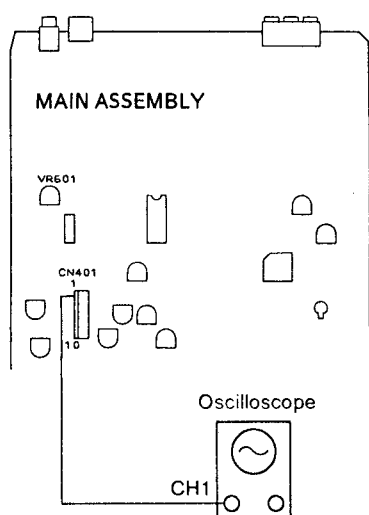

300mV ± 50mV

Fig. 1 RF signal

Oscilloscope range
5mV/div
2mS/div
AC mode

Adjustment Procedure

1. Search for frame #15,000 on the test disc.
2. Connect the oscilloscope to CN401 - 1 (RF) and observe the RF signal.
3. Adjust VR601 so that the RF signal's amplitude becomes 300mV ± 50mV. (See Fig. 1.)

8.4.5 ELECTRICAL ADJUSTMENT

13. Ref. SUB CARRIER ADJUSTMENT

Electrical Adjustment

- Purpose: Adjustment of the standard clock frequency.
- When not properly adjusted: Incorrect color tint, no TV color lock.

- | | |
|--|--|
| <ul style="list-style-type: none"> ● Measuring instruments and jigs: ● Measuring point: ● Test disc and player mode ● Positions to be adjusted | <ul style="list-style-type: none"> ● Frequency counter ● Oscilloscope 10:1 probe ● IC402 (PM0001) pin 8 ● Normal mode (Stop mode (Blueback screen)) ● VC901 |
|--|--|

Connection diagram

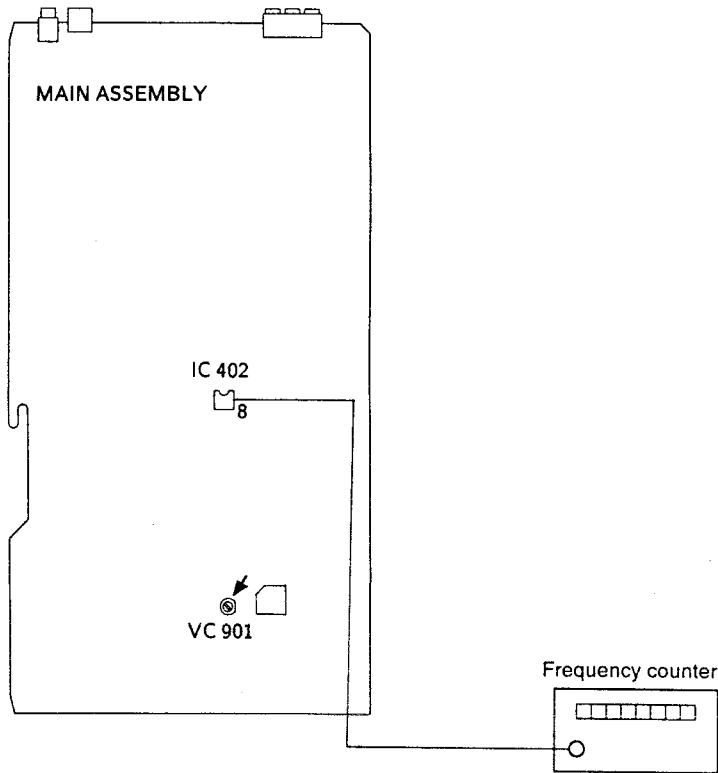

Adjustment Procedure

1. Adjust VC901 on the MAIN assembly so that the frequency of IC402 pin 8 becomes 3.579545MHz in the stop mode (blueback screen).

Note : The frequency counter probe should be an oscilloscope 10 : 1 probe.

14. VCO CENTER FREQUENCY ADJUSTMENT

Electrical Adjustment

- Purpose: Setting the optimum delay time for the time base error compensation CCD.
- When not properly adjusted: Difficult to color lock, there is color lock delay after a search, and flicker on the white screen.

- | | |
|--|---|
| <ul style="list-style-type: none"> • Measuring instruments and jigs: • Measuring point: • Test disc and player mode • Positions to be adjusted | <ul style="list-style-type: none"> • Oscilloscope • CH 1 : + side lead wire of C471. • CH 2 : + side lead wire of C499. • 8-inch LD test disc (GGV1003) • Normal mode (Still mode) • VR481 |
|--|---|

Connection diagram

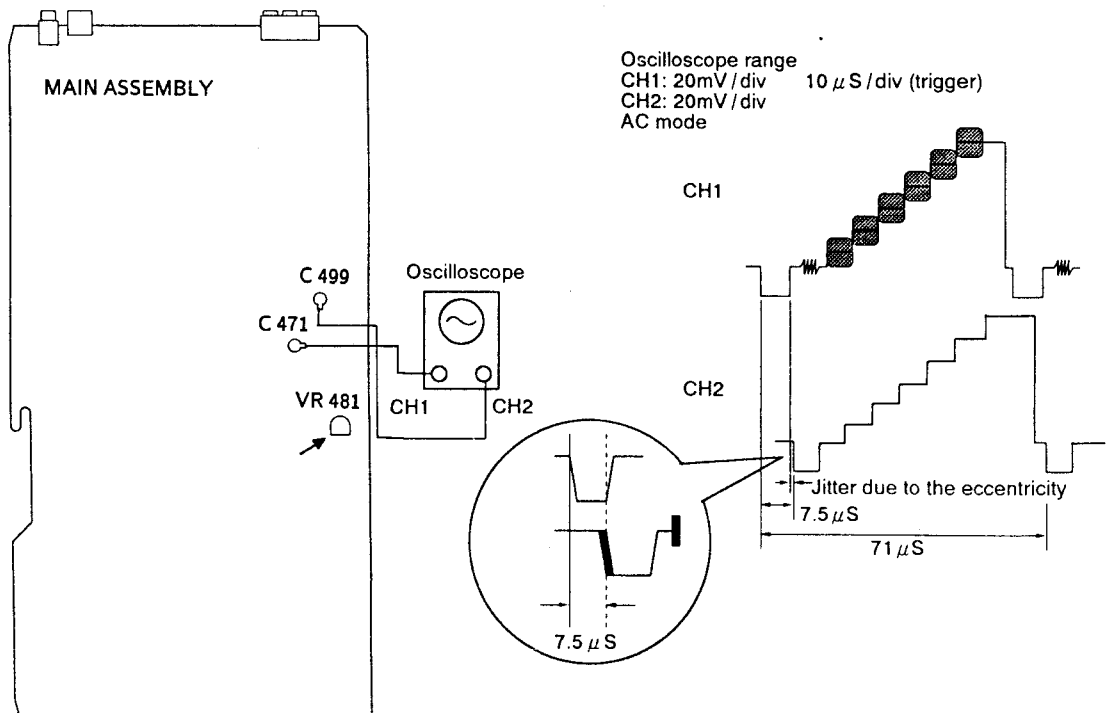

Adjustment Procedure

1. Connect the + side lead wire of C471 and the + side lead wire of C499 to CH 1 and CH 2 of the oscilloscope respectively.
 CH 1 : Video signal before time axis error compensation.
 CH 2 : Video signal after time base error compensation.
2. Search for frame #5,100 on the test disc. Adjust VR481 so that the center of CH 1's video signal jitter is delayed by 71 μs (1H + 7.5 μs) with respect to the CH 2's video signal.

Note : Do not confuse CH 1 and CH 2.

15. OUTPUT VIDEO LEVEL ADJUSTMENT

Electrical Adjustment

- Purpose: Setting the video signal level to 1Vp-p (75 Ω termination).
- When not properly adjusted: The player starts up midway without reading the data. The screen is too bright or too dark.

- | | |
|--|--|
| <ul style="list-style-type: none"> ● Measuring instruments and jigs: ● Measuring point: ● Test disc and player mode ● Positions to be adjusted | <ul style="list-style-type: none"> ● Oscilloscope ● Player's VIDEO OUT terminal ● 8-inch LD test disc (GGV1003) ● Normal mode (Still mode, #19,900) ● VR482 |
|--|--|

Connection diagram

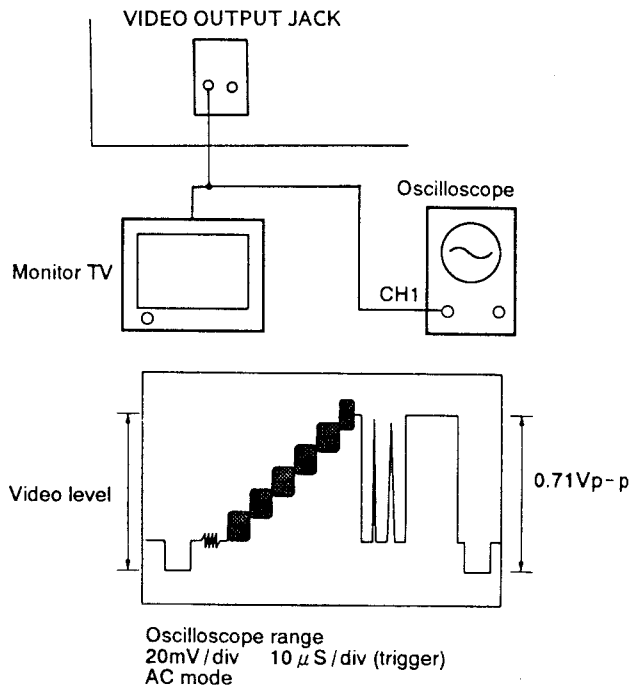
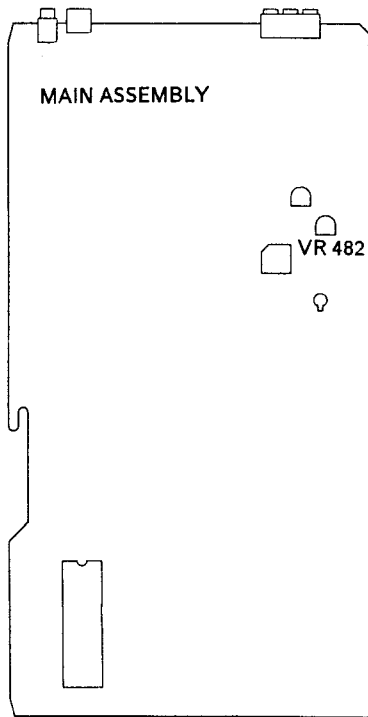

Adjustment Procedure

Note : Since the VIDEO OUT terminal is connected to a TV monitor, it is to have 75Ω termination. (If it is connected to a TV via VHF OUT, terminate the VIDEO OUT terminal with a 75Ω resistor).

1. Search for frame #19,900 on the test disc.
2. Adjust VR482 so that the white level becomes 0.71Vp-p ± 5% from the video signal's sync tip level.

16. 1H DELAY VIDEO LEVEL ADJUSTMENT

Electrical Adjustment

- Purpose: Equalization of the video levels of the 1H delay video signal and the main line video signal.
- When not properly adjusted: If the 1H delay video signal level is high, white dropout will be noticeable and there will be H shifting. (Horizontal stripes across the screen.)

- | | |
|--|--|
| <ul style="list-style-type: none"> • Measuring instruments and jigs: • Measuring point: • Test disc and player mode • Positions to be adjusted | <ul style="list-style-type: none"> • Oscilloscope • CH 1 : - side lead wire of C443 • CH 2 : - side lead wire of C445 • 8-inch LD test disc (GGV1003) • Normal mode (Still mode) • VR441 |
|--|--|

Connection diagram

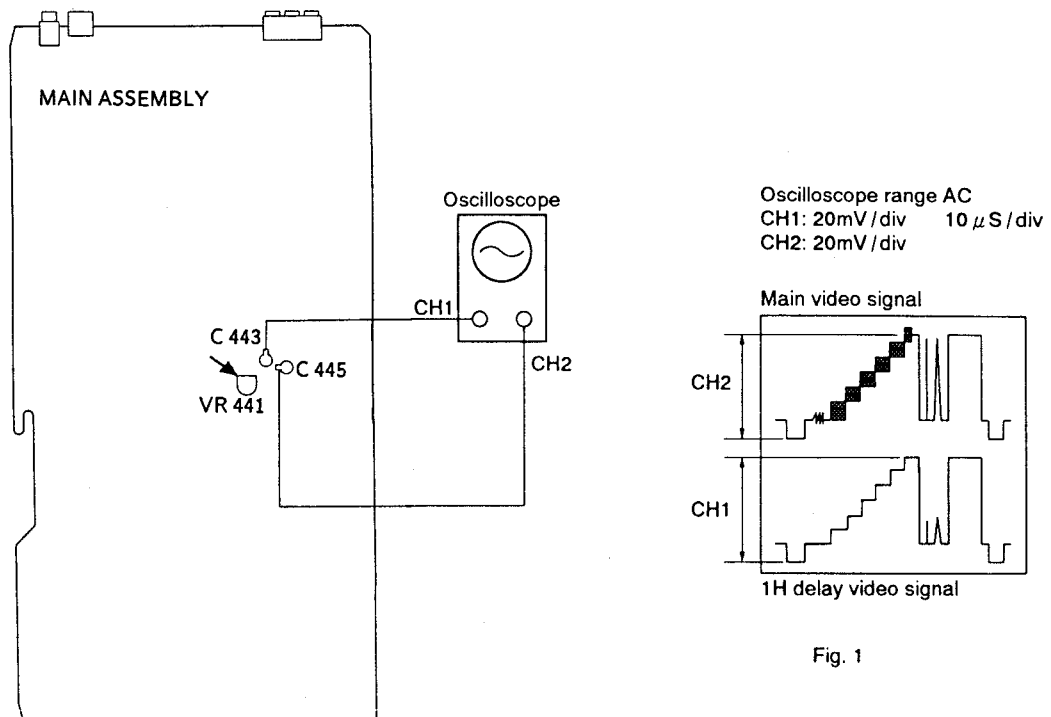

Fig. 1

Adjustment Procedure

1. Search for frame #3,800 on the test disc.
2. Connect - side lead wire of C443 to the oscilloscope's CH 1 and - side lead wire of C445 to the CH 2.
3. Adjust VR441 so that the 1H delay video level (CH 1) becomes the same as the main line video level (CH 2). (See Fig. 1)

Note : The video level is the level between the SYNC tip and the white peak.

17. VPS ERROR ADJUSTMENT

Electrical Adjustment

- Purpose: Optimization of the color tint compensation section's error signal level.
- When not properly adjusted: Substantial color irregularity. (especially on CDV.)

- | | |
|--|--|
| <ul style="list-style-type: none"> ● Measuring instruments and jigs: ● Measuring point: ● Test disc and player mode ● Positions to be adjusted | <ul style="list-style-type: none"> ● TV monitor ● 8-inch LD test disc (GGV1003) ● Normal mode (Still mode) ● VR521 |
|--|--|

Connection diagram

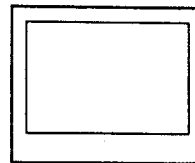
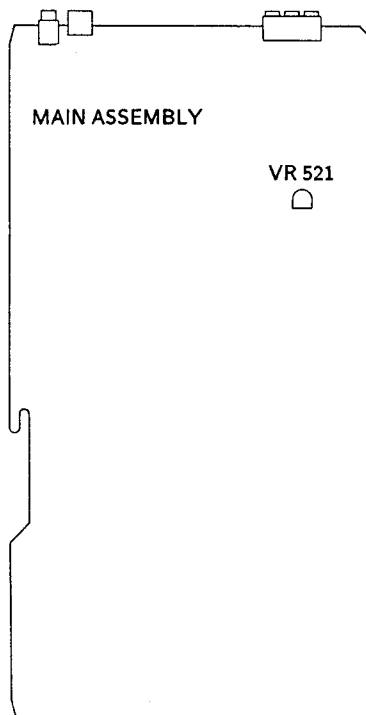

Color irregularity on the magenta screen is minimized.

Adjustment Procedure

1. Search for frame #8,000 on the test disc. (Magenta screen)
2. Adjust VR521 until the color irregularity on the magenta screen is minimized.

9. MECHANICAL DESCRIPTION

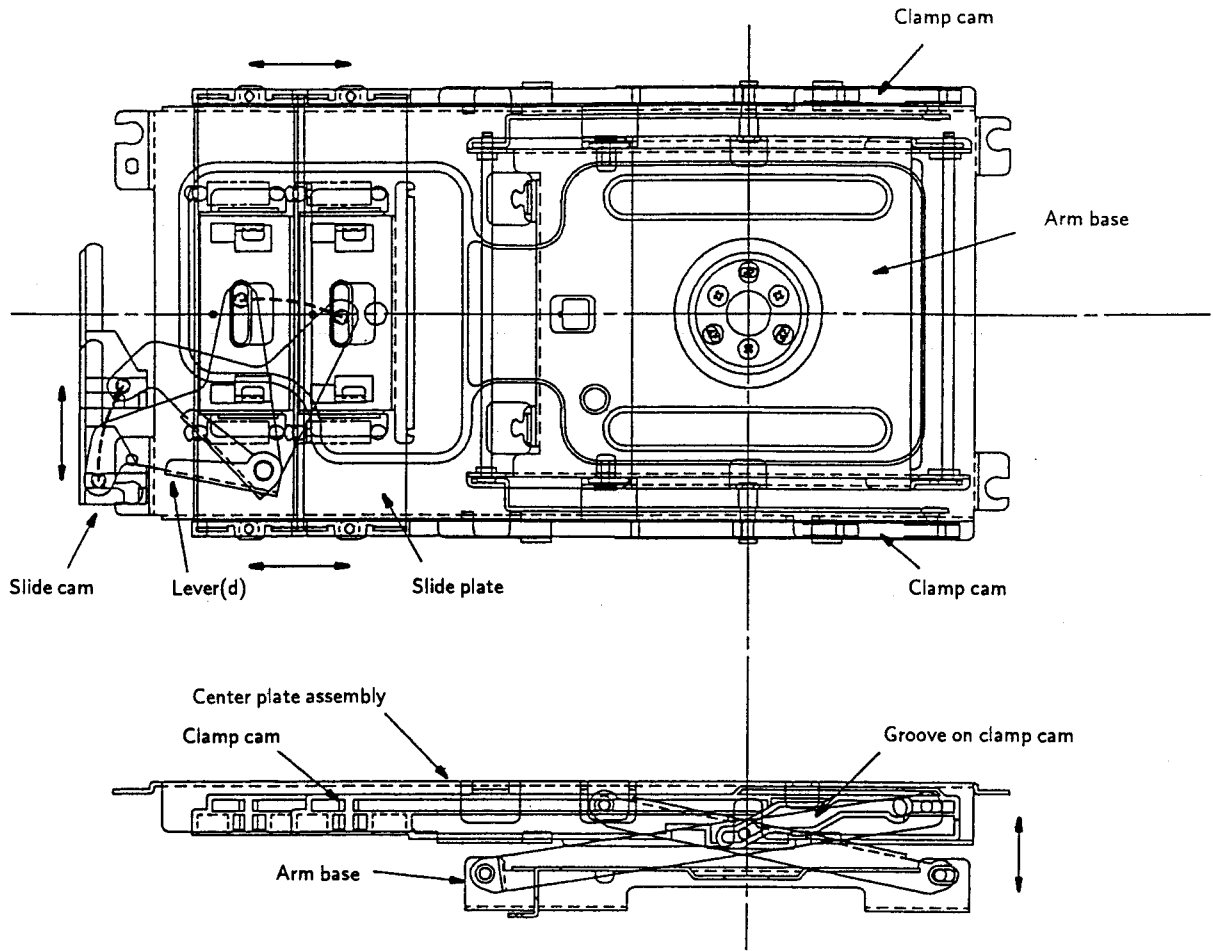

9.1 ARM HEIGHT MECHANISM

When the loading motor moves the slide cam up and down as shown in the fig. above, lever (D) begins rotating to move the slide plate horizontally. This operation then causes a pair of clamp cams to move right and left synchronously. At this point, the link starts rotating along the groove on

the clamp cam and the arm base connected to the link moves vertically. This movement causes the rotary arm (that is supported by the base gear which is fixed to the arm base for rotation) to move vertically.

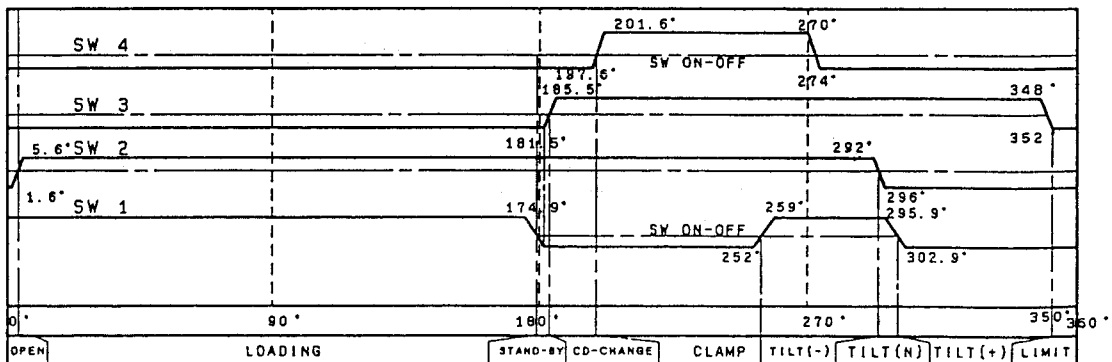

Operational Flow Chart of Loading Motor

9.2 ARM ROTARY MECHANISM

The rotary arm is supported by the ball bearing which fits it to a position that can be rotated with the base gear fixed to the arm base. The arm rotary drive section mounted on the

rotary arm rotates, then runs along the rack on the circumference of the base gear, centering on the bearing.

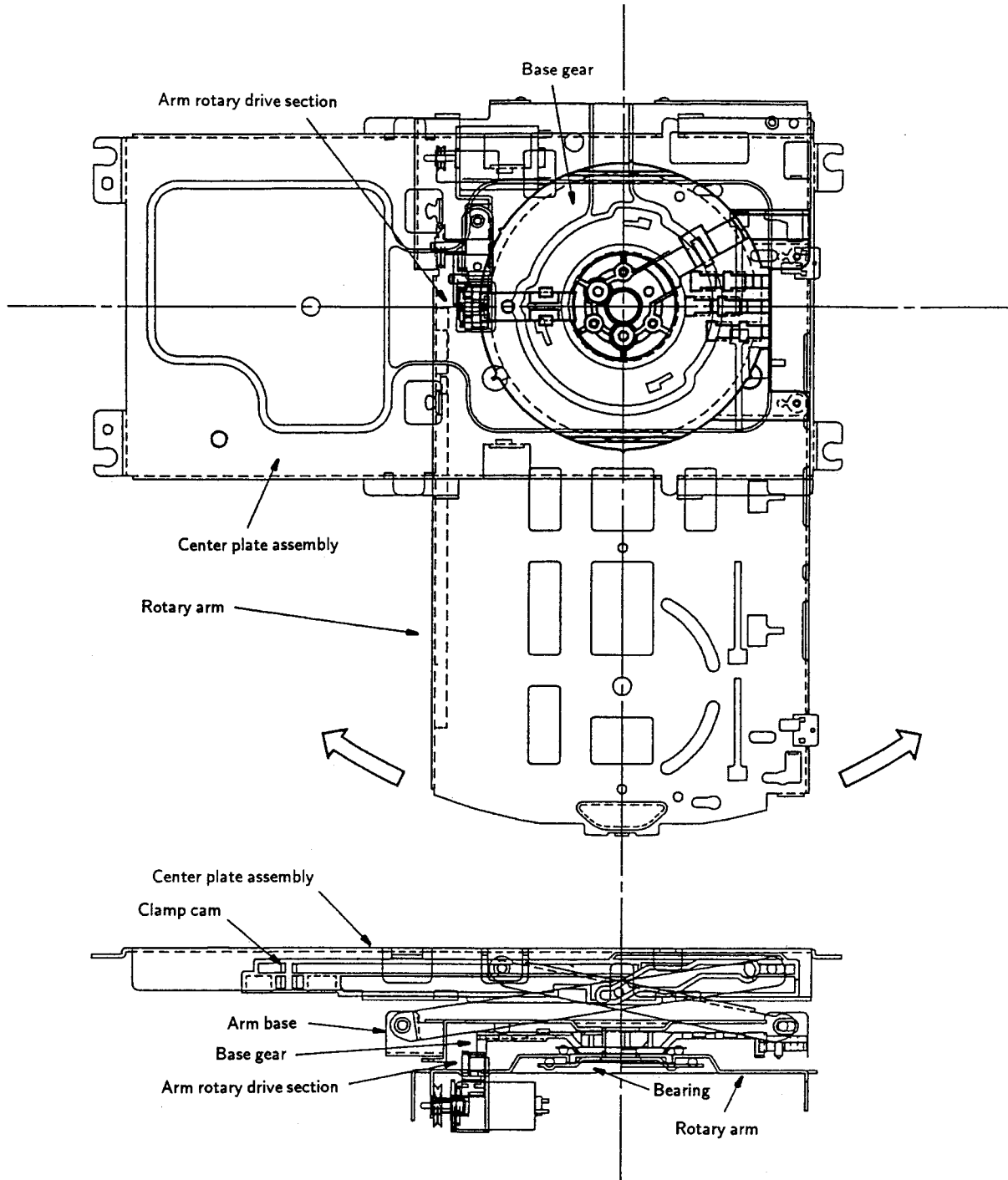

9.3 DETECTION OF ARM ROTATION POSITION

The arm rotation position is detected by combination of the codes for three switches (SW 6, SW 7 and SW 8) as shown in SW cam operation chart. When the rotary arm rotates,

the three SW levers moves horizontally along the three grooves on the SW cam, causing SW 6, SW 7 and SW 8 to turn ON and OFF.

9.4 POSITIONING OF ARM ROTATION : BALL LOCK

Approximate positioning for arm rotation are performed electrically by combination of the codes of the three switches (SW6, SW7 and SW8). Also, precise positioning is performed

by the ball mounted on the insertion hole on the base bear when this ball is fit into the dent (corresponding to the angle for the 5 CD fixed positions) on the SW cam.

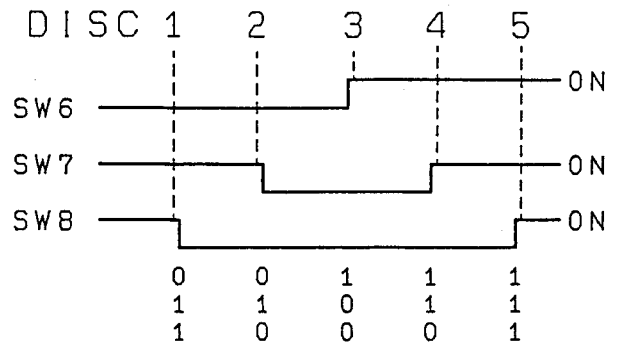
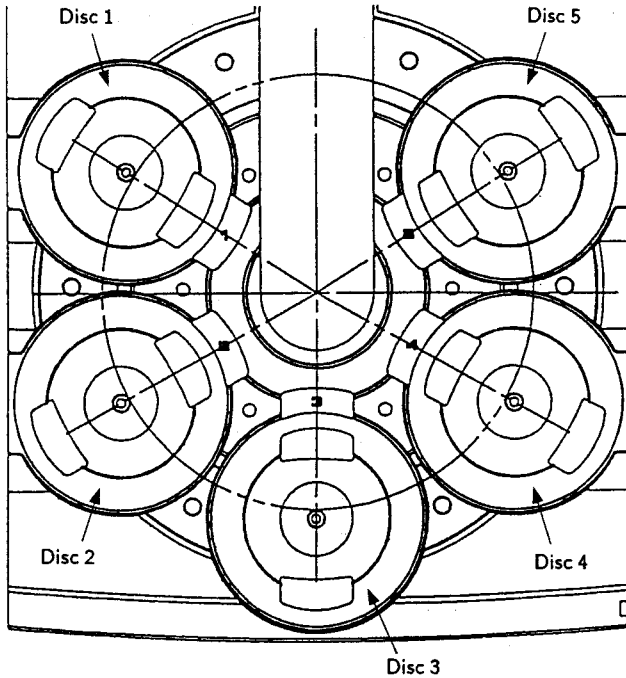

SW Cam Operation Chart

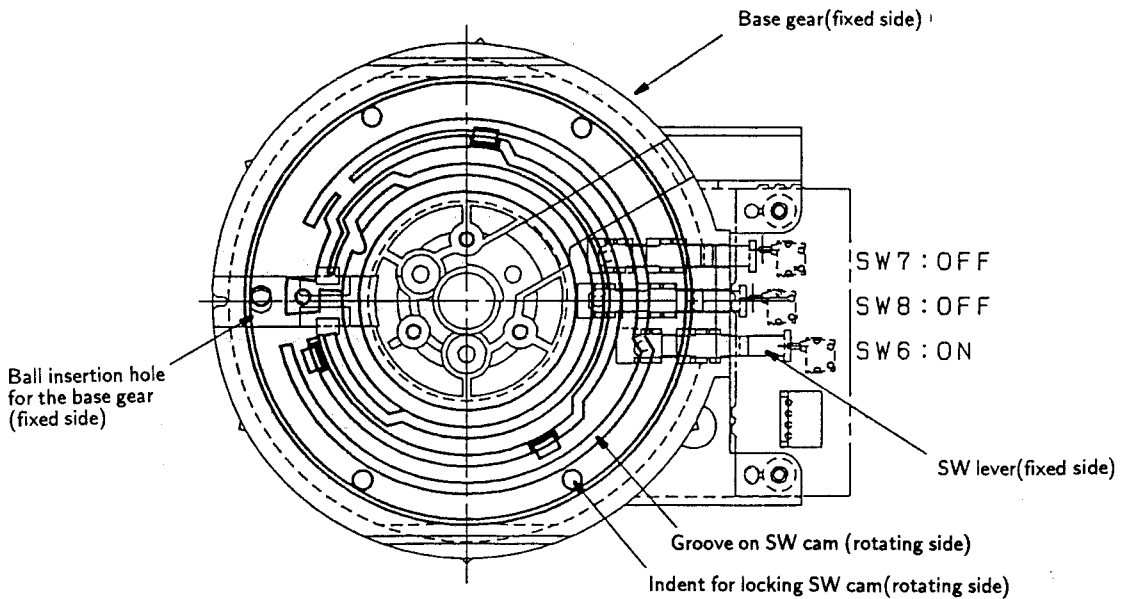

Configuration at DISC : 3 Position

9.5 CD movement mechanism (PLAY)

Five CD fixed positions on the tray

Rotary arm which supports the clamper

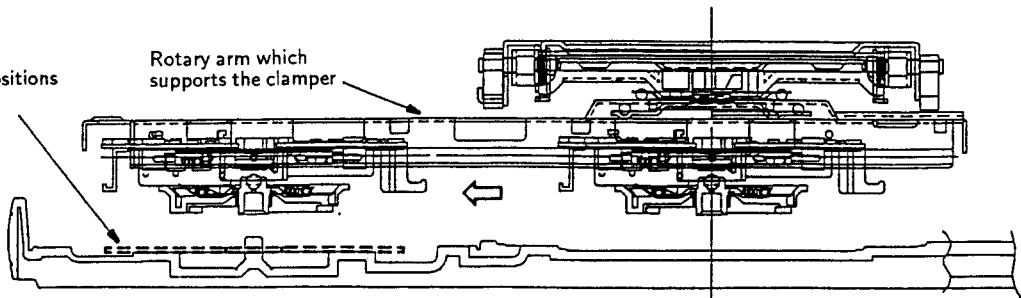

<1> Clamper : Moving outward

When the carriage motor rotates with the CD holders set in the original position, the clamper moves horizontally to the outer CD fixed position. Three CD holders are built into the clamper

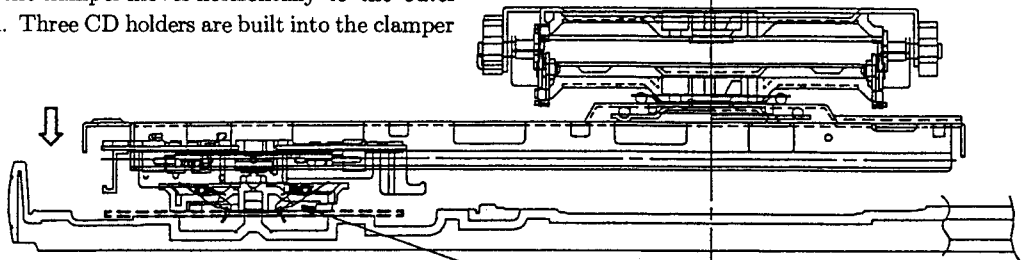

<2> Picks up the disc on the tray

When the rotary arm is lowered by the loading motor, the CD holders are opened by rotation of the carriage motor to pick up the center section of the disc.

Three CD holders are built into the clamper

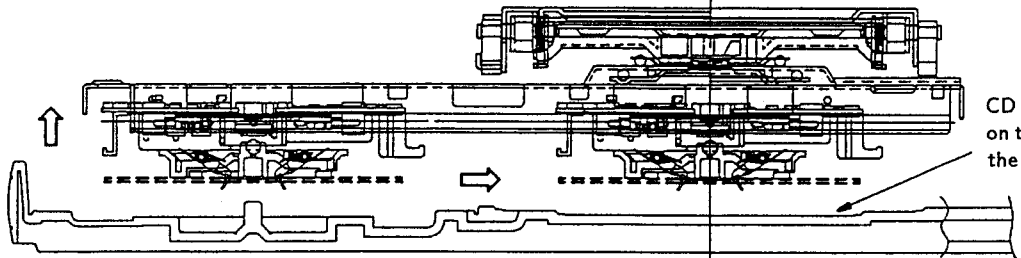

CD loading side on the center of the tray

<3> Clamper : moves inward

After the loading motor moves the rotary arm up with the disc clamped at the inter diameter, the disc is positioned in the center of the tray by rotation of the carriage motor.

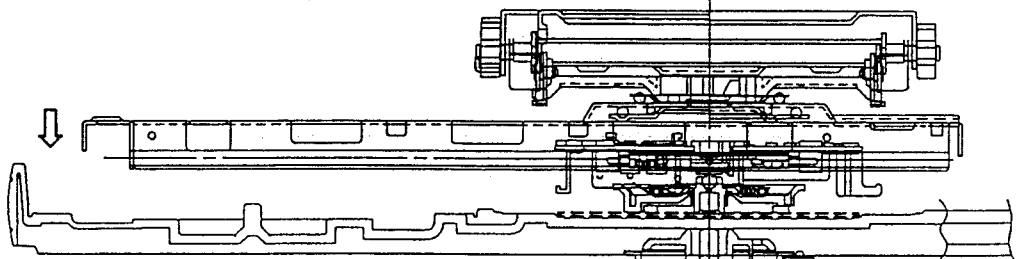

<4> Releases the disc on the tray

After the rotary arm is lowered by the loading motor, the CD holders reset to their original position and release the disc.

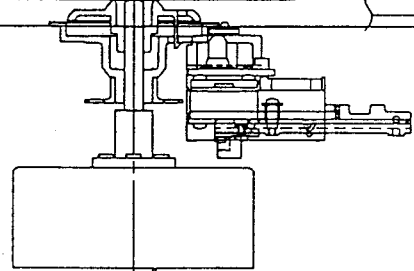

9.6 CD MOVEMENT MECHANISM (STOP)

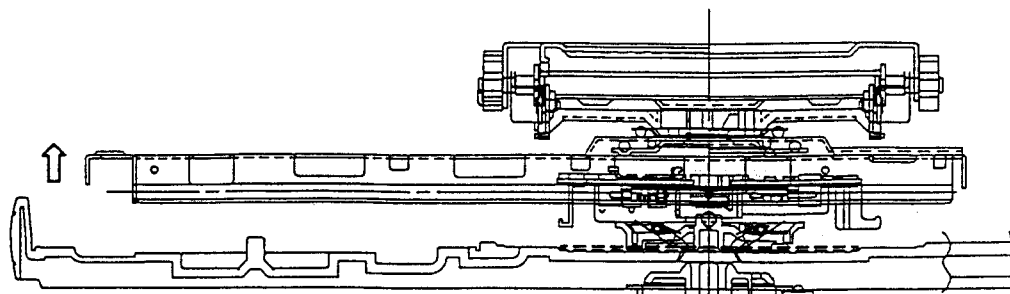

<5> Picks up the disc on the tray

After the rotary arm and the tray are moved up by the loading motor, the CD holders are opened by rotation of the carriage motor and pick up the center section of the disc.

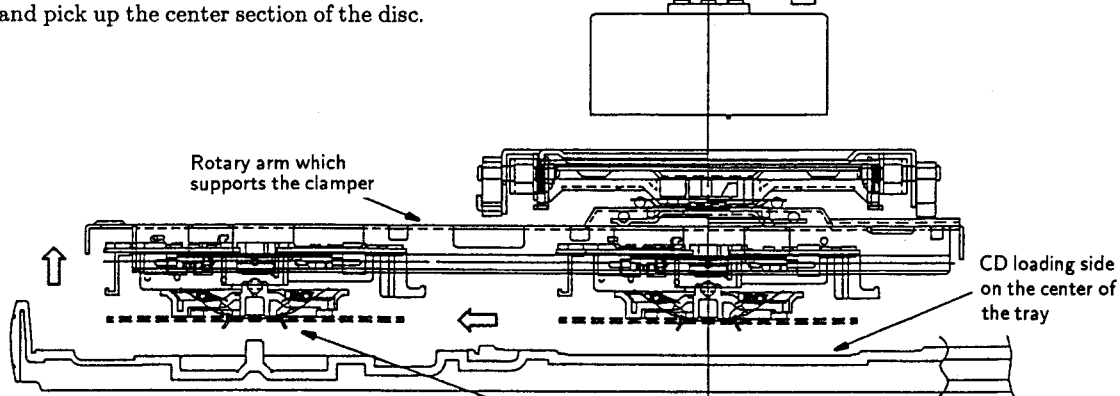

<6> Clamber : moves outward

When loading motor moves the rotary arm further up after the disc is picked up in the center section, the carriage motor turns and so that the disc holders move the outer rim of the disc.

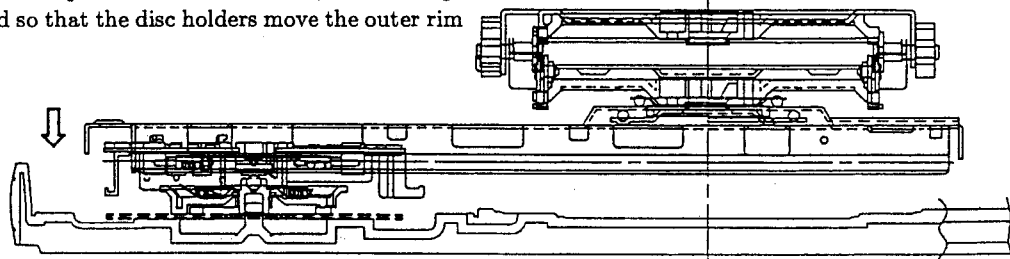

<7> Releases the disc on the tray

After the loading motor lowers the rotary arm, the CD holders reset to their original positions and release the disc.

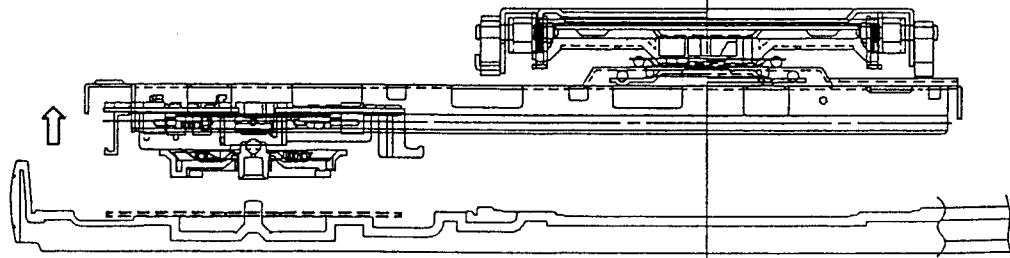

<8> Clamber: Stands by at outer section of the disc.

When the loading motor moves the rotary arm upward with the CD holder positioned at the original position, the clamber is positioned at the outer rim of the disc and set for standby.

9.7 CD DRIVE MECHANISM (PLAY)

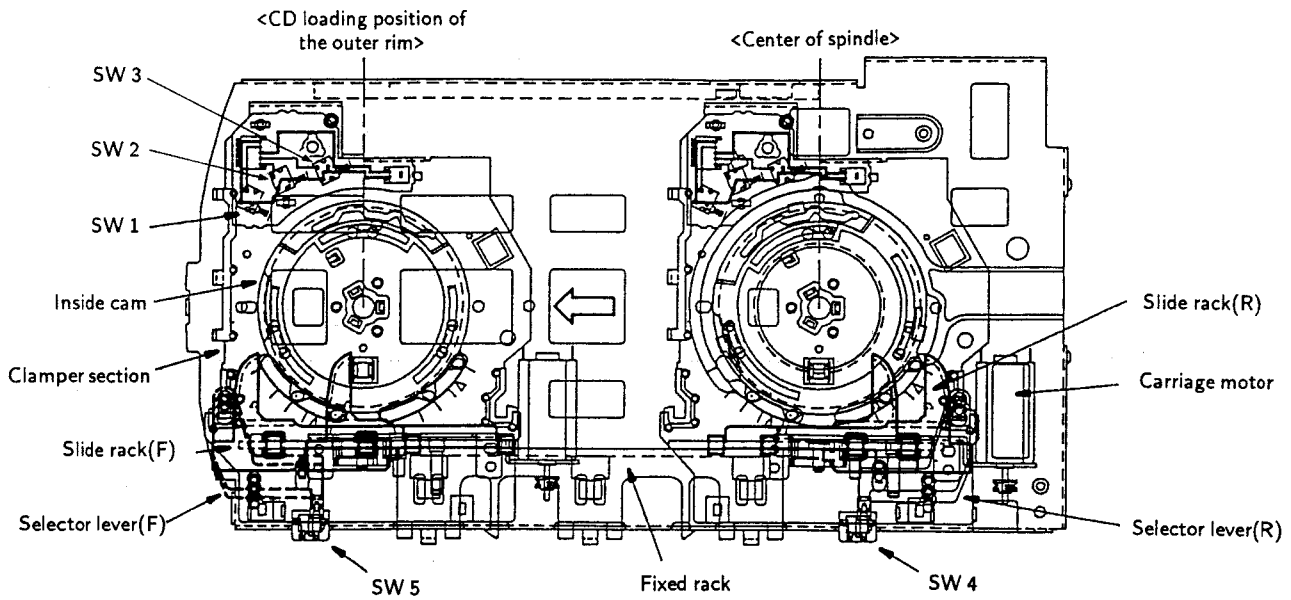

<1> Clamper moves to outer rim

The carriage motor moves the clamper on the fixed rack, then the clamper is locked by the selector lever (F). This moves the slide rack (F) to the right. When the selector lever (F) is switched, SW 5 turns ON to detect that the clamper is positioned at the outer rim.

<2> Picks up disc

When the slide rack (F) moves, the pin for the inside cam is rotated to position (2). This opens the three CD holders built into the clamper and they are open to clamp the disc.

This state is detected by turning ON/OFF of SW 1, SW 2 and SW 3 by the lever rotated by the inside cam.

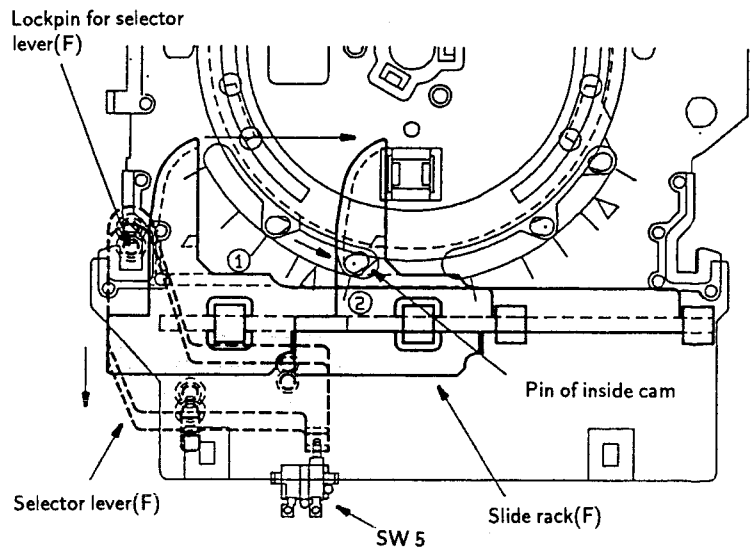

<3> Clamper moves to inner rim

After the CD holders clamp the disc, the carriage motor rotates in reverse and the slide cam (F) moves to the left. But the inside cam does not rotate and the CD holders continue to clamp the disc.

When the side rack (F) moves to the left end, the selector lever (F) locks the slide rack (F). At this time, the carriage motor moves the clamper to inner rim over the fixed rack.

<4> Releases the disc

When the clamper moves to the center, the selector lever (R) moves to lock the clamper. At this time, the slide rack (R) moves to the left. The selector (R) turns SW 4 ON to detect that the clamper is positioned at the center.

When the slide rack (R) moves to rotate the pin for the inside cam to position (1), the three CD holders built into the clamper close to release the disc.

This state is detected when the SW 1, SW 2 and SW 3 are turned ON and OFF by the lever rotated by rotation of the inside cam.

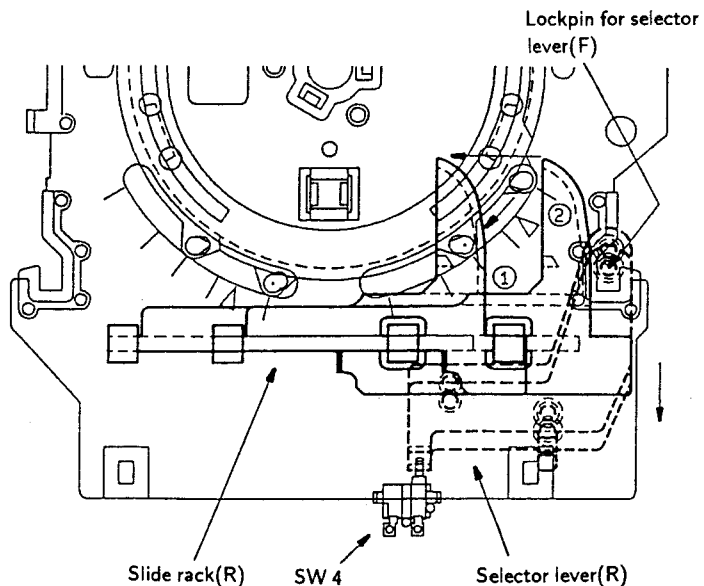

9.8 CD DRIVE MECHANISM (STOP)

<5> Clamps the disc

When clamping the disc at the inner rim, the carriage motor moves the slide rack (R) to the left, causing the pin for the inside cam to rotate to position (3). Then the three CD holders built into the clamper open to clamp the disc.

This state is detected when SW 1, SW 2 and SW 3 are turned ON and OFF by the lever rotated by rotation of the inside cam.

<6> Clamper moves to the outer rim

After the clamper picks up the CD, the carriage motor rotates in reverse to move the slide rack (R) to the right. But the inside cam does not rotate and continues to clamp the disc.

When the slide rack (R) moves to the right end, the selector lever (R) locks the slide rack (R) to releases the clamper, then the carriage motor moves the clamper over the fixed rack outward.

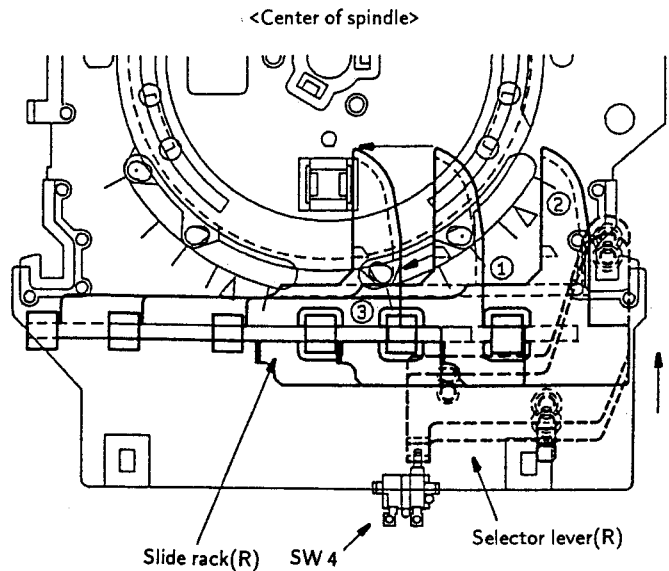

<7> Releases the disc

When the clamper reaches the center rim, the selector lever (F) moves to lock the clamper. At this time, the slide rack (F) will move to the right. The selector lever (F) turns SW 5 ON to detect that the clamper is positioned at outer rim.

When the slide rack (F) moves causing the pin for the inside cam to rotate to position (1), the three CD holders built into the clamper close to release the disc. This state is detected when SW 1, SW 2 and SW 3 are turned ON and OFF by the lever turned by the rotation of the inside cam.

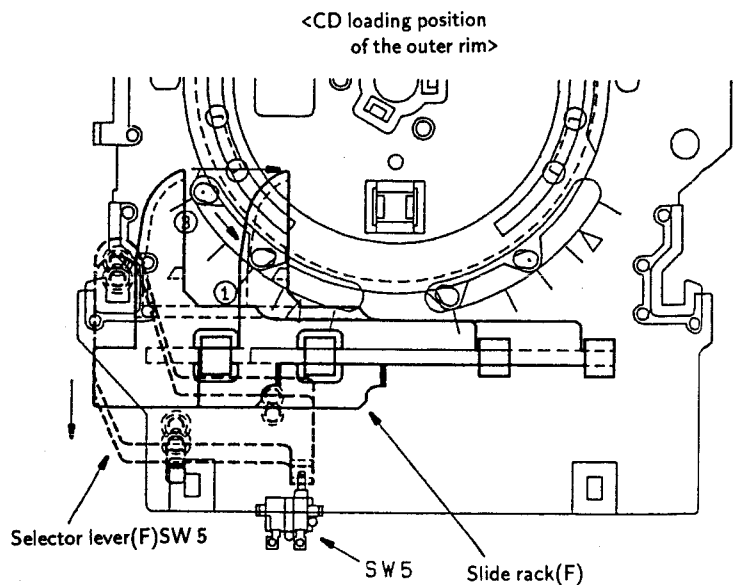

9.9 CD HOLDER OPEN/CLOSE MECHANISM

<CD holder open/close mechanism>

The three CD holders built into the clamper are usually locked to the close direction by the holder springs. The CD holders are opened and closed when the inside cam rotates to move the cam lever along the cam groove and the slider moves up and down.

<CD holder operation position detection>

The positional detection for open/close operation of the CD holders are performed by combination of the codes generated by SW 1, SW 2 and SW 3 which turn ON and OFF by the three levers rotating in the groove on the inside cam.

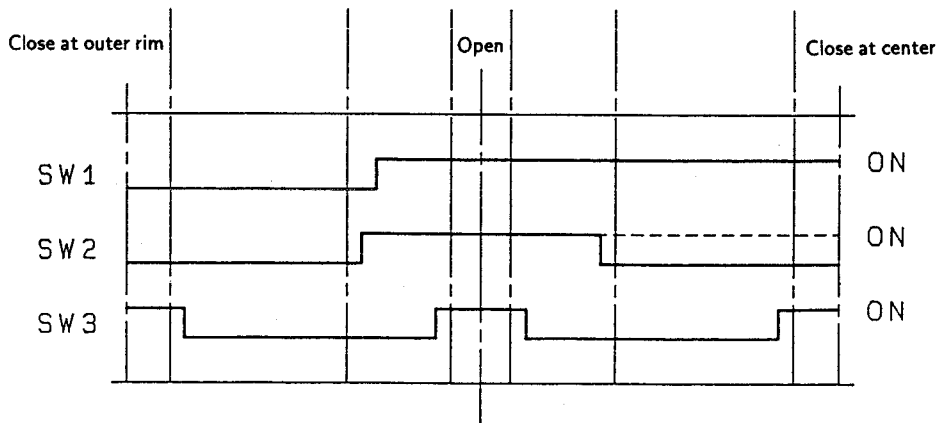
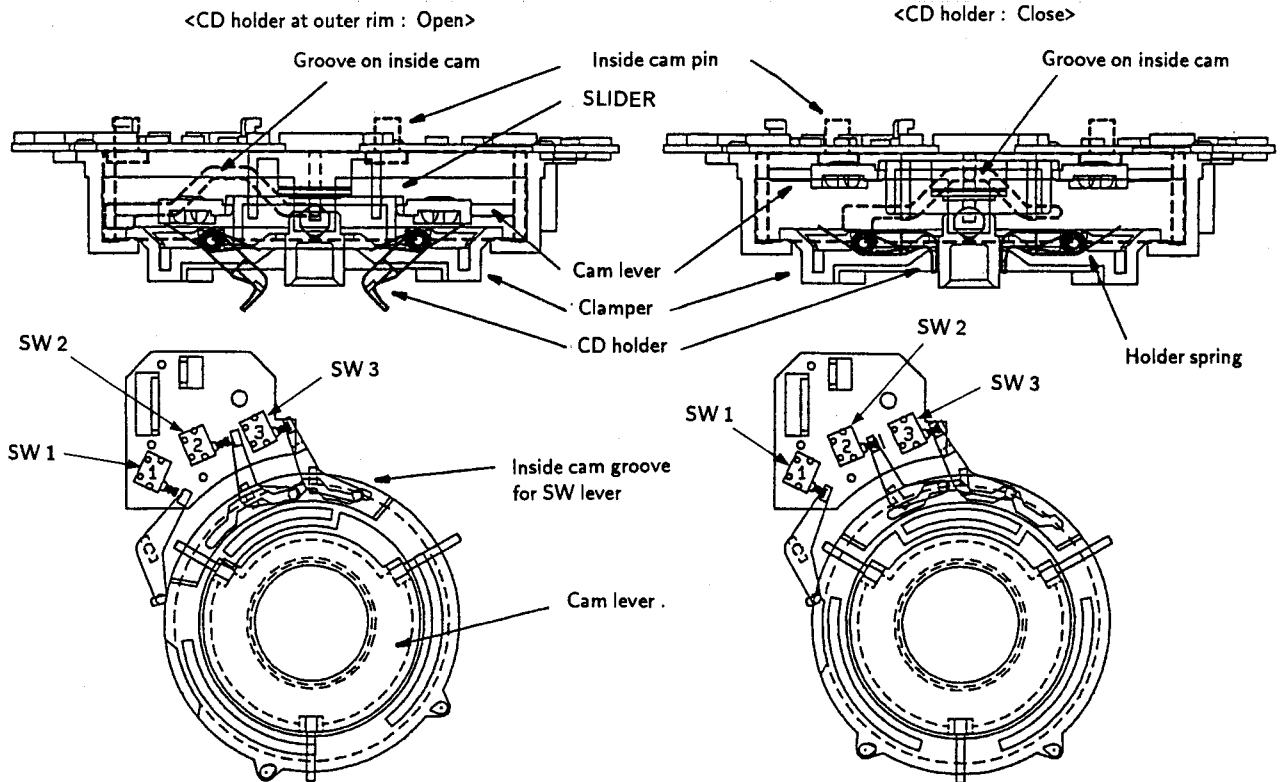

CD Holder Open/Close Flow Chart

9.10 Specification

MODEL NO.	CLD-M 90
	KUC
MP	'91/6~7
Description	MULTI CLD
Colour	Black/Gray
RCU	Normal (35 key)
Audio Characteristics	
Digital filter	8 fs, 20 bit
D/A converter	1-bit
FREQ. response 4-20 K	(±0.5 dB)
Audio S/N	(110 dB)
Dynamic range	(99 dB)
Channel separation	(100 dB)
T.H.D	(0.002%)
Wow and flutter	Unmeasurable
Video Characteristics	
Comb filter	×
Digital TBC	×
Horizontal resolution	425 lines
Video S/N	(49 dB)
Outputs	
VHF adapter output	○
# S-VIDEO output	×
# VIDEO output	2
# AUDIO output	2
Digital output	×
Control In/Out SR	○
CD-DECK synchro	○
Headphone jack	○

Main Functions	
Direct CD	VIDEO PWR OFF
CD Peak search	×
Single play	×
Last memory	○
PGM EDIT/COMPU PGM EDIT	○
Random play	○
5-CD random play	○
RCU Power on/off	○
New CD level meter	○
Shuttle for CLEAR SCAN	×
Video NR	×
Intro/Hilite scan	2-mode Hilite
Program play	24-step
Music calendar	FL/OSD
ADLC	○
Volume control	×

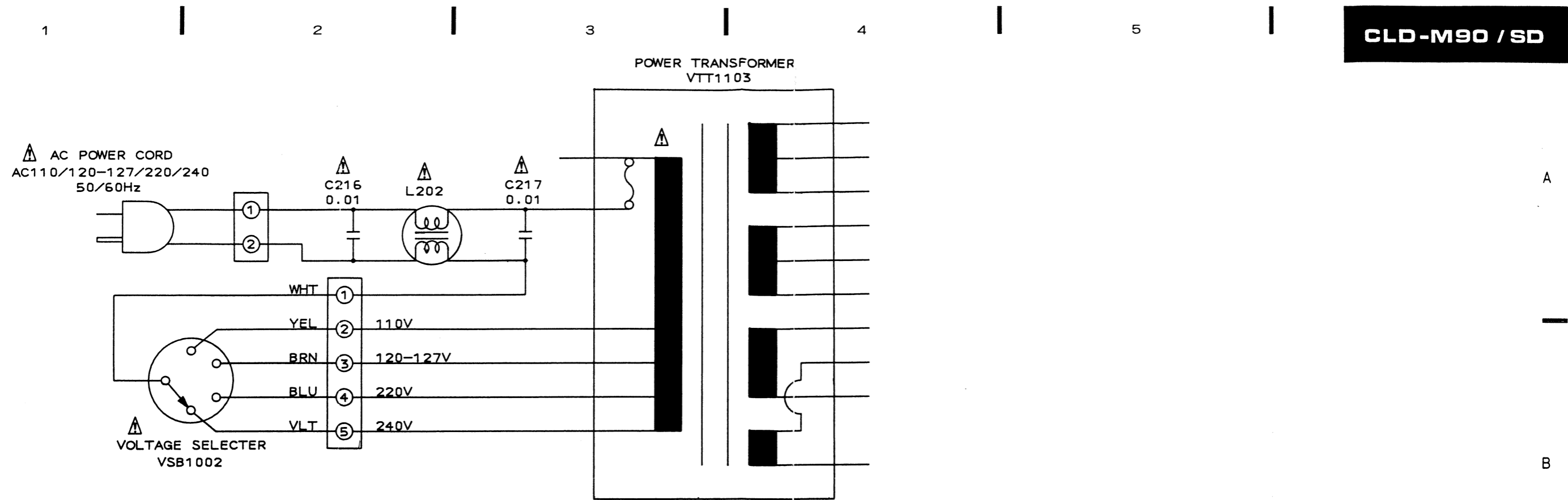

- | | | | |
|-------|-------|-------|-------|
| Q206 | Q205 | Q214 | Q201 |
| Q204 | Q203 | Q213 | Q219 |
| IC206 | IC201 | IC218 | IC202 |
| | | | Q207 |

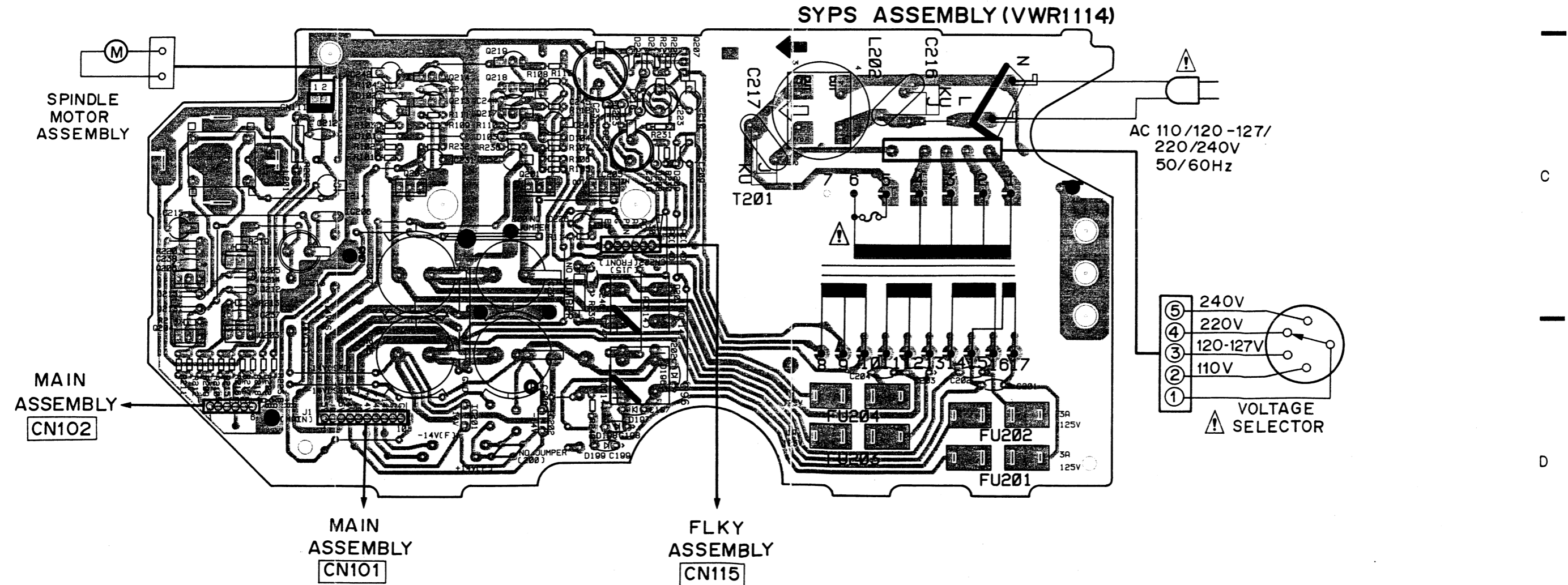

10. FOR SD TYPE

• CONTRAST OF MISCELLANEOUS PARTS

NOTES :

- Parts without part number cannot be supplied.
- Parts marked by "●" are not always kept in stock. Their delivery time may be longer than usual or they may be unavailable.
- The △ mark found on some component parts indicates the importance of the safety factor of the part. Therefore, when replacing, be sure to use parts of identical designation.

The CLD-M90/SD type is the same as the CLD-M90/KUC type with the exception of the following sections.

Mark	Symbol & Description	Part No.		Remarks
		KUC	SD	
●	SYPS assembly	VWR1108	VWR1114	
	Strain relief	CM-22C	CM-22B	
△	AC power cord	PDG1015	PDG1013	
△	Line voltage selector (AC 110/120-127/220/240 V)	VS1002	
△	Power transformer (AC 120 V)	VTT1096	
△	Power transformer (AC 110/120-127/220/240 V)	VTT1103	
	Packing case	VHG1168	VHG1191	For packing
	Operating instructions (Spanish)	VRK1002	

SYPS ASSEMBLY(VWR1114)

The SYPS assembly (VWR1114) is the same as the SYPS assembly (VWR1108) with the exception of the following sections.

Mark	Symbol & Description	Part No.		Remarks
		VWR1108	VWR1114	
	R241	RD1/2PM225J	

11. PANEL FACILITIES

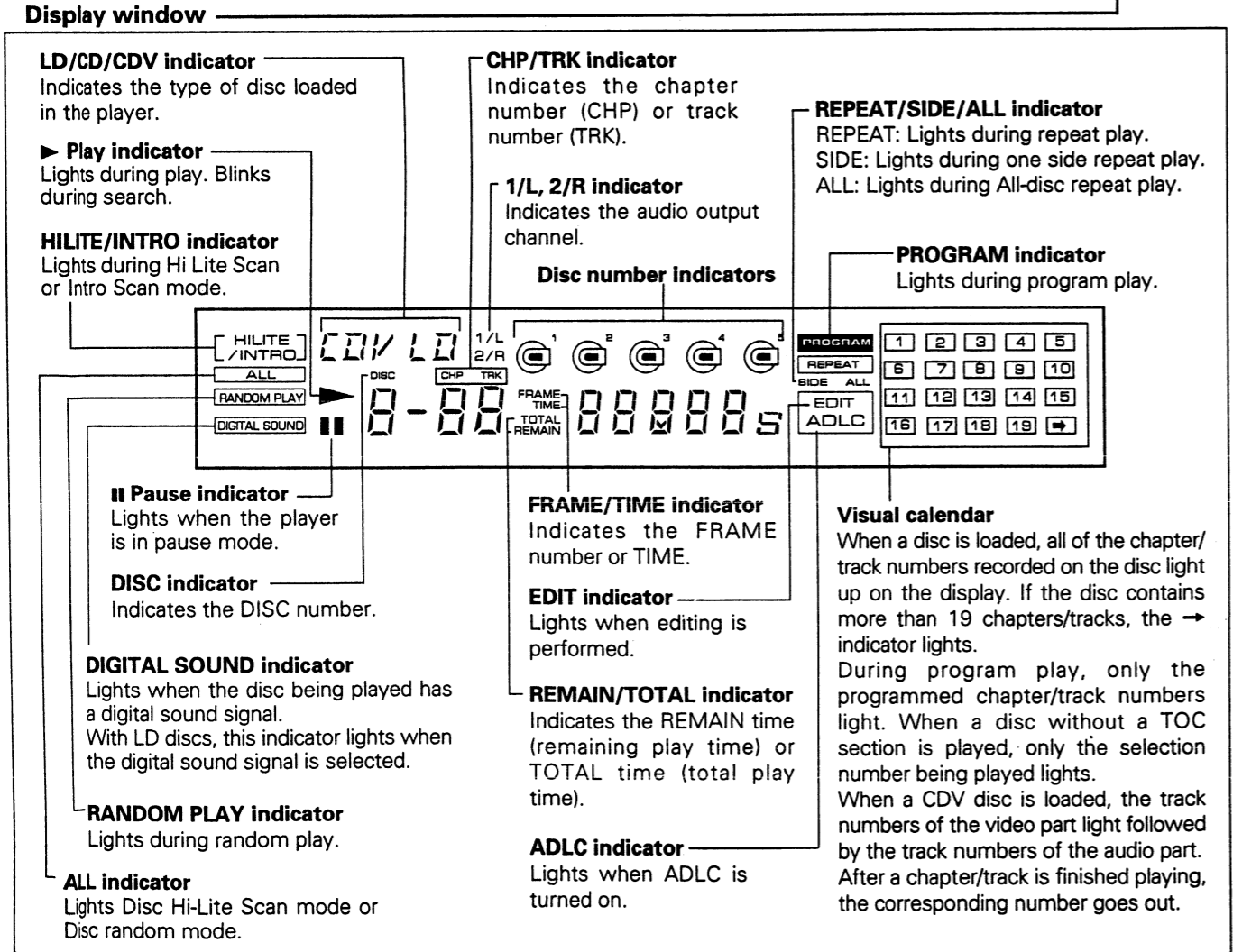
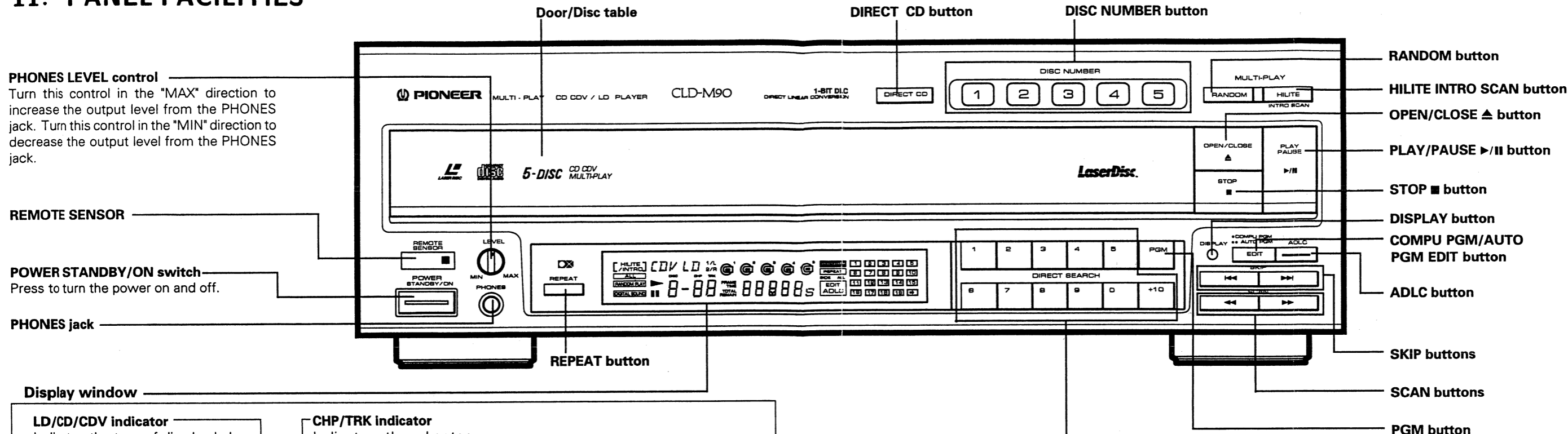

Remote control buttons with the same names or marks as buttons on the front panel of the player control the same operations as the corresponding front panel buttons.

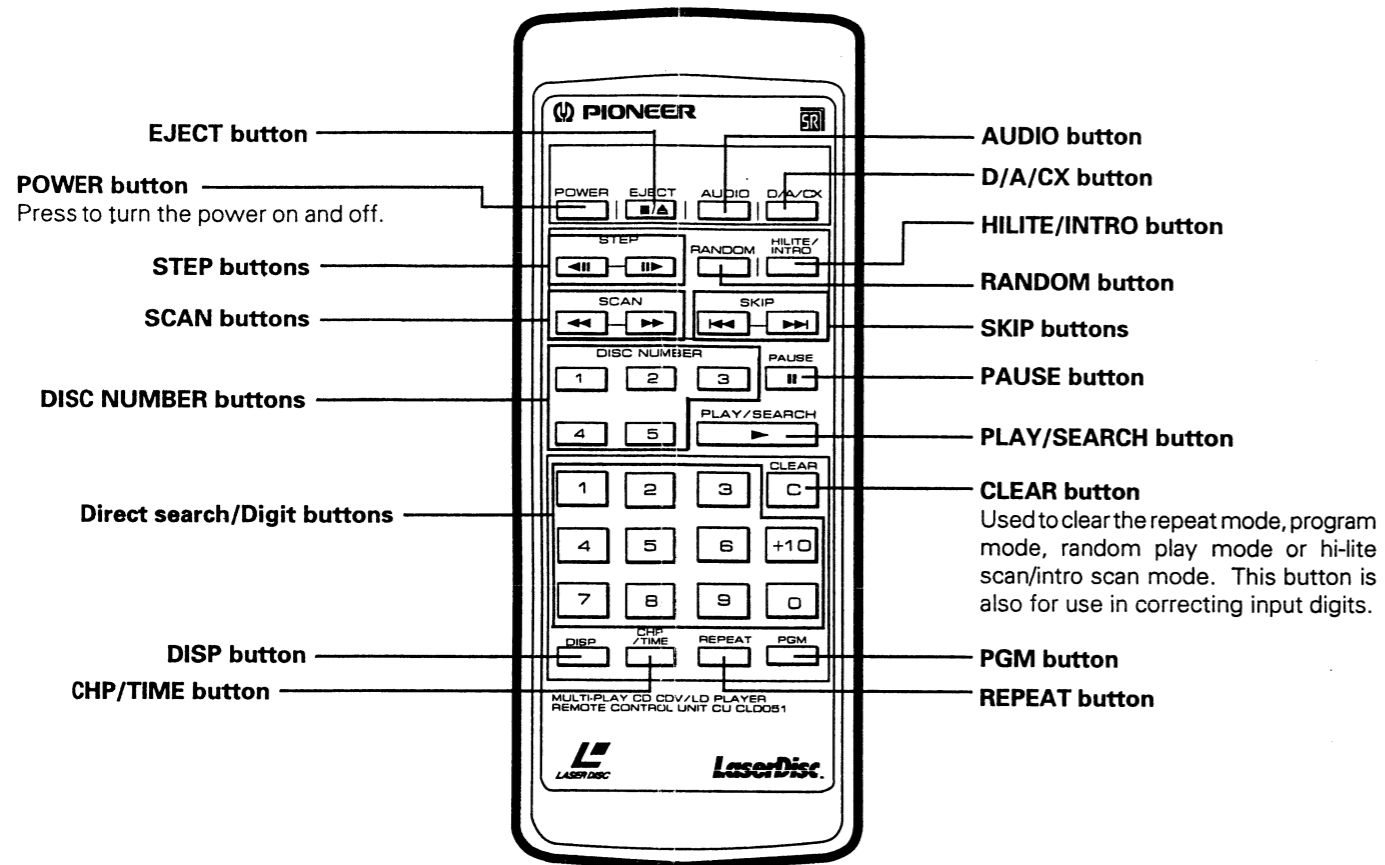

When operating the remote control unit, point the unit's infrared signal transmitter at the remote control receiver (REMOTE SENSOR) on the front panel of the player. The remote control unit can be used within a range of about 7 meters (23 feet) from the remote sensor, and within angles of up to about 30 degrees.

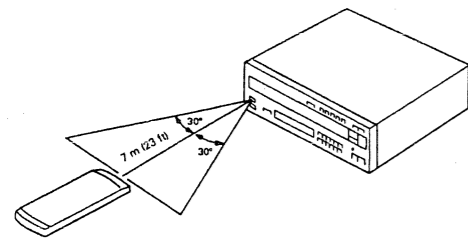

NOTE FOR USING THE REMOTE CONTROL UNIT

● If a plug is connected to the CONTROL IN terminal at the rear of the player, remote control operations cannot be done with the remote control unit aimed at the player's remote control sensor. Aim the remote control unit at the AV control center or the component display's sensor instead.

- If there is any obstacle between the remote control unit and the player, or if the unit is held at too large an angle relative to the front panel of the player, the signal from the remote control unit will fail to reach the remote sensor.
- If the player is operating in the vicinity of other appliances generating infrared rays, or if other remote control devices using infrared rays are used near the player, the player may operate improperly. Conversely, if the player's remote control unit is operated in the vicinity of other appliances which use an infrared remote control device, the other appliance may operate improperly. If this should happen, change the place of installation so that improper operation does not occur.
- If the range of operation of the remote control unit becomes too short, replace the batteries.
- When the unit is not to be used for a long period of time (more than one month), remove the batteries to prevent them from leaking inside the compartment. If leakage occurs, wipe up the liquid inside the compartment and replace the batteries with new ones.
- Do not place books or other objects on the remote control unit, since they might depress the buttons and run down the batteries.
- If the remote control sensor window is in a position where it receives strong light such as sunlight or fluorescent light, control may not be possible.

12. SPECIFICATIONS

1. General

System LaserVision Disc system and Compact Disc digital audio system
 Laser Semiconductor laser wavelength 780 nm
 Power requirements
 U.S. and Canadian models AC 120V, 60 Hz
 Multi voltage model AC 110V/120-127V/220V/240V (Switchable), 50/60 Hz
 Power consumption 39 W
 Weight 9.5 kg (20 lbs 15 oz)
 Dimensions 420 (W) x 450 (D) x 142 (H) mm
 16-9/16 (W) x 17-11/16 (D) x 5-9/16 (H) in
 Operating temperature +5°C ~ +35°C
 (41°F - 95°F)
 Operating humidity 5% ~ 90%
 (There should be no condensation of moisture.)

2. Disc

LaserVision Discs

*Maximum playing times
 12-inch standard play disc 1 hour/both sides
 12-inch extended play disc 2 hours/both sides
 8-inch standard play disc 28 min/both sides
 14 min/one side
 8-inch extended play disc 40 min/both sides
 20 min/one side
 Spindle motor speed
 Standard play disc 1,800 rpm
 Extended play disc 1,800 rpm (inner circumference)
 to 600 rpm (outer circumference)
 (For a 12-inch disc)

Compact Discs

DISC Diameter: 5-inch, 3-inch, Thickness: 1.2 mm
 Rotation direction (pickup side) Counterclockwise
 Liner speed 1.2 ~ 1.4m/sec
 *Maximum playing time
 74 min. 5-inch discs
 20 min. 3-inch discs
 (For stereo playback)

Compact Discs with Video

Disc Diameter: 5-inch, Thickness: 1.2 mm
 Rotation direction (pickup side) Counterclockwise
 Linear speed Audio portion: 1.2 ~ 1.4m/sec
 Video portion: 11 ~ 12m/sec
 *Maximum playing time Video portion: 5 min. (CLV)
 Audio portion: 20 min. (Digital)

* Actual playback time differs for each disc.

3. Video characteristics (two pairs)

Format NTSC specifications
 Video output
 Level 1 Vp-p nominal, sync. negative, terminated
 Impedance 75Ω unbalanced
 Jack RCA jack

4. Audio characteristics (two pairs)

Output level
 During analog audio output 200 mVrms
 (1 kHz, 40%)
 During digital audio output 200 mVrms
 (1 kHz, -20 dB)
 Jacks Both RCA jacks
 Number of channels 2

Digital Audio Characteristics

Frequency response	4 Hz - 20 kHz (±0.3 dB) (EIAJ)
SN ratio	112 dB (EIAJ)
Dynamic range	99 dB (EIAJ)
Channel separation	105 dB (EIAJ)
Total harmonic distortion	0.0019% (EIAJ)
Wow and flutter	Limit of measurement (EIAJ)

5. Other Terminals

Control input/output Both miniature jacks
 CD-DECK synchro Miniature jack
 VHF adapter output (Video/Audio) Both RCA jacks
 with DC jack

6. Accessories

Remote control unit (CU-CLD051) 1
 Size "AAA" (IEC R03) dry cell batteries 2
 Video cord 1
 Audio cord 1
 Operating instructions 1
 Warranty card 1

7. Functions

Remote control unit operations (CU-CLD051)

	Function	Standard play Disc (CAV)	Extended play Disc (CLV)	Compact Disc with Video	Compact Disc
Basic Functions	Single-side play Pause Stop	YES YES YES	YES YES YES	YES YES YES	YES YES YES
Search	Fast forward (forward and reverse) Chapter/Track skip Direct chapter/Track number search Frame number search Time number search Absolute time search Disc search	YES YES YES YES NO NO NO	YES YES YES NO YES NO NO	YES YES YES NO YES NO YES	YES YES YES NO YES YES YES
Program	Chapter/Track program play Program correction	YES YES	YES YES	YES YES	YES YES
Repeat	Chapter/Track repeat One-side repeat All-disc repeat Program repeat Random repeat Program random repeat	YES YES NO YES YES*1 YES	YES YES NO YES YES*1 YES	YES YES YES YES YES YES	YES YES YES YES YES YES
Trick play	Still/Step	YES	NO	NO	NO
Time display	Elapsed time display Absolute time display Remaining track time display Remaining total time display Total number of selections, total time display	NO YES*1 NO YES*1 YES*1	YES NO NO YES*1 YES*1	YES NO YES YES YES	YES YES YES YES YES
Others	Hi-Lite scan Intro scan CX system ON/OFF AUTO DIGITAL/ANALOG switch Audio channel selection (Stereo, 1/L, 2/R)	NO YES YES*2 YES*3 YES	NO YES YES*2 YES*3 YES	YES*4 YES*5 NO NO YES	YES NO NO NO YES

*1 Only discs with TOC

*2 Valid for analog sound playing a disc with the  mark.

*3 Can only be used with discs with digital sound tracks.

*4 Audio part only

*5 Video part only

NOTE:

The specifications and design of this product are subject to change without notice, due to improvement.

PLAYER FUNCTIONS

- Display, Visual Calendar Display
- Intro Scan, Hi-Lite Scan, Direct CD, ADLC, Random Playback, Disc Random Playback, Program Random Playback and Compu Program/Auto Program Edit
- Digital Sound for LaserVision Discs
- Last Memory