

Service Manual

PIONEER
The Art of Entertainment

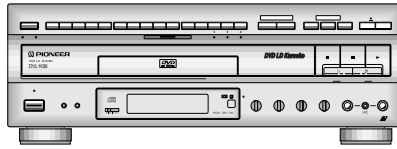

ORDER NO.
RRV1902

DVD LD PLAYER

DVL-K88

THIS MANUAL IS APPLICABLE TO THE FOLLOWING MODEL(S) AND TYPE(S).

Type	Model	Power Requirement	The voltage can be converted by the following method.	Regional restriction codes (region number)
	DVL-K88			
RL	O	AC 110 – 127V/220 – 240V	Automatic select	3

- Refer to the service guide RRV1896 for DV-505.
IC information is described in the service guide.

CONTENTS

1. SAFETY INFORMATION	2	7. GENERAL INFORMATION	78
2. EXPLODED VIEWS AND PARTS LIST	3	7.1 IC	78
3. SCHEMATIC DIAGRAM	16	7.2 DISASSEMBLY/ASSEMBLY	80
4. PCB CONNECTION DIAGRAM	40	7.3 BLOCK DIAGRAM	82
5. PCB PARTS LIST	56	8. PANEL FACILITIES AND SPECIFICATIONS	84
6. ADJUSTMENT	63		

PIONEER ELECTRONIC CORPORATION 4-1, Meguro 1-Chome, Meguro-ku, Tokyo 153-8654, Japan
PIONEER ELECTRONICS SERVICE, INC. P.O. Box 1760, Long Beach, CA 90801-1760, U.S.A.
PIONEER ELECTRONIC (EUROPE) N.V. Haven 1087, Keetberglaan 1, 9120 Melsele, Belgium
PIONEER ELECTRONICS ASIACENTRE PTE. LTD. 501 Orchard Road, #10-00 Lane Crawford Place, Singapore 0923
 © PIONEER ELECTRONIC CORPORATION 1998

1. SAFETY INFORMATION

This service manual is intended for qualified service technicians; it is not meant for the casual do-it-yourselfer. Qualified technicians have the necessary test equipment and tools, and have been trained to properly and safely repair complex products such as those covered by this manual.

Improperly performed repairs can adversely affect the safety and reliability of the product and may void the warranty. If you are not qualified to perform the repair of this product properly and safely, you should not risk trying to do so and refer the repair to a qualified service technician.

IMPORTANT
THIS PIONNER APPARATUS CONTAINS LASER OF CLASS 1. SERVICING OPERATION OF THE APPARATUS SHOULD BE DONE BY A SPECIALLY INSTRUCTED PERSON.

LASER DIODE CHARACTERISTICS

- FOR DVD
MAXIMUM OUTPUT POWER : 7 mw
WAVELENGTH : 650 nm
- FOR CD/LD
MAXIMUM OUTPUT POWER : 5 mw
WAVELENGTH : 780-785 nm

LABEL CHECK

CAUTION	: VISIBLE AND INVISIBLE LASER RADIATION WHEN OPEN. : AVOID EXPOSURE TO BEAM.
VORSICHT	: SICHTBARE UND UNSICHTBARE LASERSTRAHLUNG, WENN ABDECKUNG GEÖFFNET NICHT DEM STRAHL AUSSETZEN!
ADVARSEL	: SYNLIG OG USYNLIG LASERSTRÅLING VED ÅBNING : UNGÅ UDSÆTTELSE FOR STRÅLING.
VARNING	: SYNLIG OCH OSYNLIG LASERSTRÅLNING NÄR DENNA DEL ÄR ÖPPNAD BETRÄKTA EJ STRÅLEN.
VARO!	: AVATTAESSA ALTISTUT NÄKYVÄ JA NÄKYMÄTTÖMÄLLE : LASERSATEILYLLE. ÄLÄ KATSO SÄTEESÄN.

VRW1699

**CLASS 1
LASER PRODUCT**

(Printed on the Rear Cover)

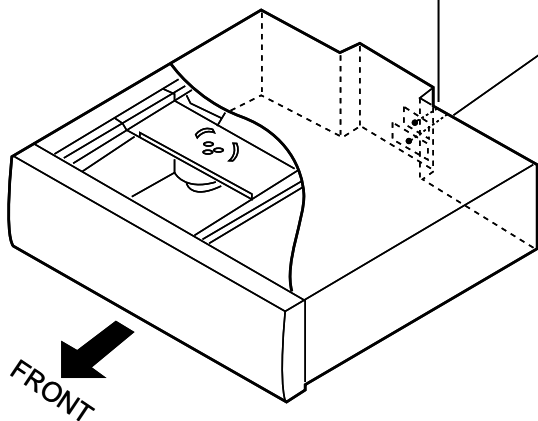

Additional Laser Caution

1. The ON/OFF statuses of the side-A/B detection switch (Lever switch connecting to the TNMB assy), slider-position detection switches (INNER and OUTER on the PKSB assy), loading-status detection switches (SW1, 2 and 3 on the LMSB assy), side B inside detection switch (S901 on the BISB assy) and CLD pickup active detection switch (S903 on the LCSB assy) are detected by the microprocessor (IC101 in the CLD MAIN assy). Also the DVD pickup active detection switch (S902 on the DCSB assy) is detected by the microprocessor (IC501 in the DVD MAIN assy).
 - To permit the laser diode of CLD pickup to oscillate, it is required to set the CLD pickup active detection switch (S903 : OFF) and the slider-position detection switches for the LD ACTIVE status (INNER : OFF, OUTER: OFF), and to set the loading-status detection switches for tilt neutral state (SW1 : ON, SW2 : OFF, SW3 : ON). As long as these requirements are not satisfied, the laser diode will not oscillate. When the requirements are met in any way, the laser diode can oscillate. The laser diode oscillation will continue if pin 13 of IC801 is shorted to GND or the emitter and collector of Q834 are shorted each other (fault condition) in the CLD MAIN assy.
 - To permit the laser diode of DVD pickup to oscillate, it is required to set the DVD pickup active detection switch (S902 :OFF) and each switch and a state of laser diode are contents same as state of CLD pickup mentioned above. The laser diode oscillation will continue if pin 13 of IC101 is shorted to +5V (fault condition) in the DVD MAIN assy. In the test mode *, the laser diode oscillates when the microprocessor detects a PLAY signal, or when the PLAY key is pressed (S107 ON in the FLKB assy), with the above requirements satisfied.
2. When the cover is open, close viewing through the objective lens with the naked eye will cause exposure to a Class 1 laser beam.

* : Refer to page 66.

2. EXPLODED VIEWS AND PARTS LIST

- NOTES: ● Parts marked by "NSP" are generally unavailable because they are not in our Master Spare Parts List.
 ● The ⚠ mark found on some component parts indicates the importance of the safety factor of the part. Therefore, when replacing, be sure to use parts of identical designation.
 ● Screws adjacent to ▼ mark on product are used for disassembly.

2.1 PACKING

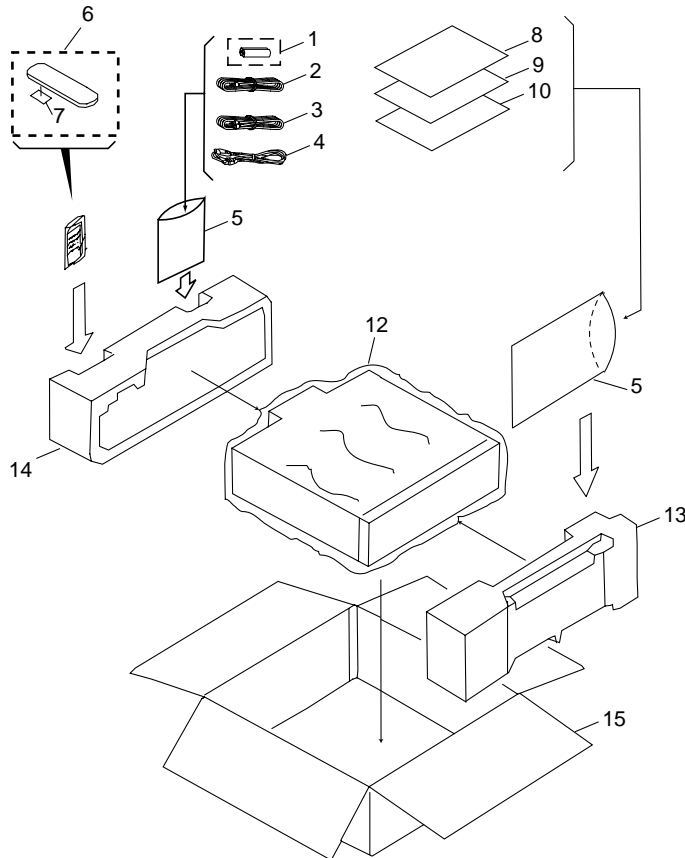

● PARTS LIST

Mark	No.	Description	Part No.
NSP	1	DRY CELL BATTERY(AA/R6P)	VEM-013
	2	VIDEO CORD(L=1.5m)	VDE1048
	3	AUDIO CORD(L=1.5m)	VDE1033
⚠	4	AC POWER CORD	ADG1127
	5	POLYETHYLENE BAG	Z21-038
	6	REMOTE CONTROL UNIT (CU-DV016)	VXX2537
	7	BATTERY COVER	VNK3703
NSP	8	CAUTION	VRM1071
	9	OPERATING INSTRUCTIONS (ENGLISH)	VRB1191
	10	OPERATING INSTRUCTIONS (TRAD-CHINESE)	VRD1079
	11	●●●●●	
	12	MIRROR MAT SHEET	VHL1018
	13	PAD F	VHA1206
	14	PAD R	VHA1207
	15	PACKING CASE	VHG1728

2.2 EXTERIOR SECTION

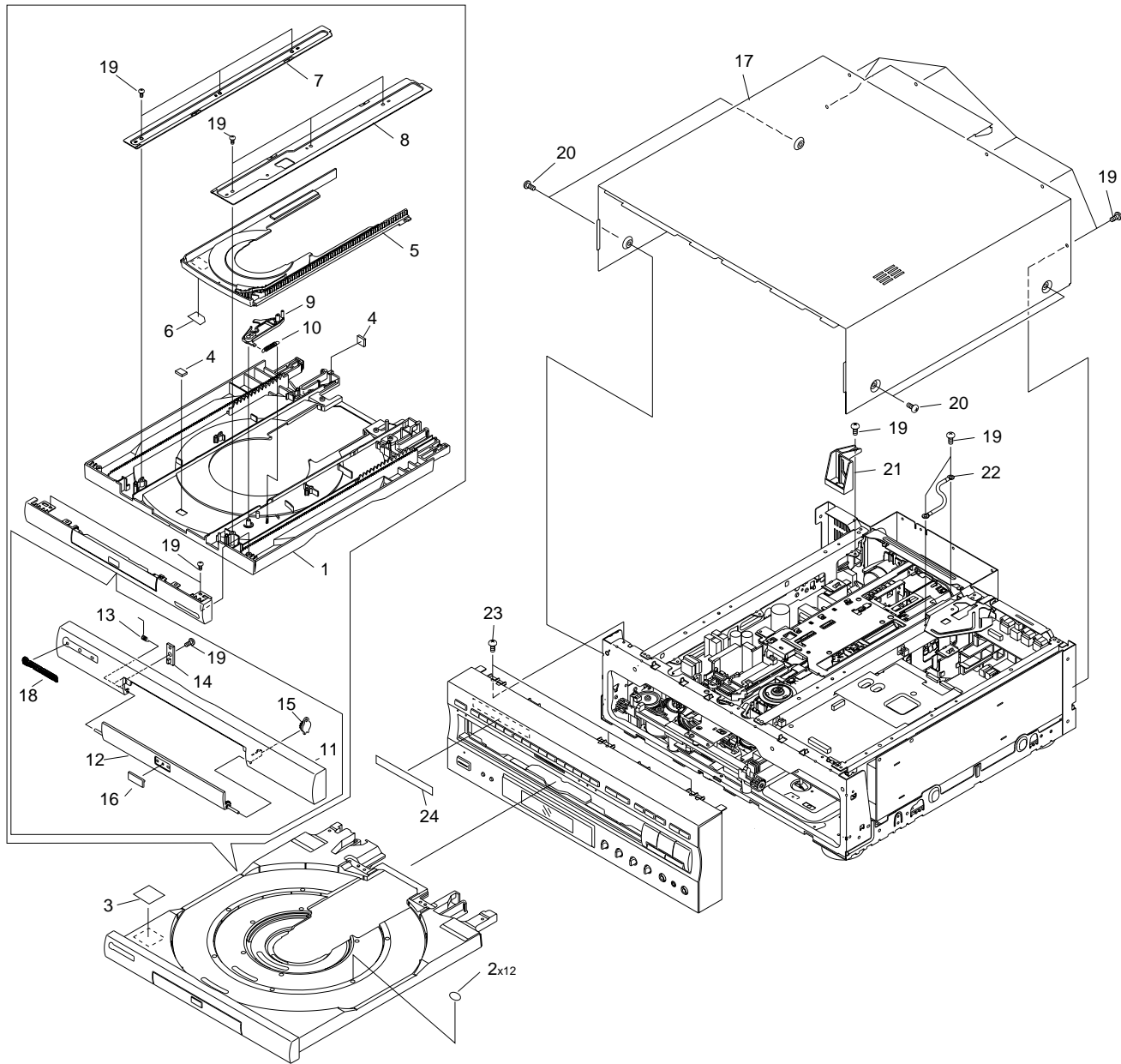

● PARTS LIST

Mark	No.	Description	Part No.	Mark	No.	Description	Part No.
	1	LD TRAY ASSY	VXA2173		11	TRAY PANEL	VNK4187
	2	CUSHION	VEC1682		12	DVD DOOR ASSY	VXA2355
NSP	3	LABEL	VRW1289		13	DOOR SPRING	VBH1248
	4	DAMP CUSHION	VEC1683		14	DOOR HOLDER	VNL1697
	5	CD TRAY	VNK3922		15	DAMPER	VXA1999
	6	LABEL	VRW1628		16	DVD PLATE	VAM1075
	7	GUIDE PLATE (R)	VNE1939		17	BONNET CASE S	VXX2561
	8	GUIDE PLATE (L)	VNE1938		18	NAME PLATE	VAM1073
	9	LOCK PLATE	VNL1703		19	SCREW	BBZ30P080FMC
	10	LOCK PLATE SPRING	VBH1188		20	SCREW	BCZ40P060FZK
					21	SHIPPING CAM	VNL1729
				NSP	22	CORD WITH PLUG	DE007VF0
					23	SCREW	IBZ30P080FMC
				NSP	24	GETTER	VRW1720

2.3 FRONT PANEL SECTION

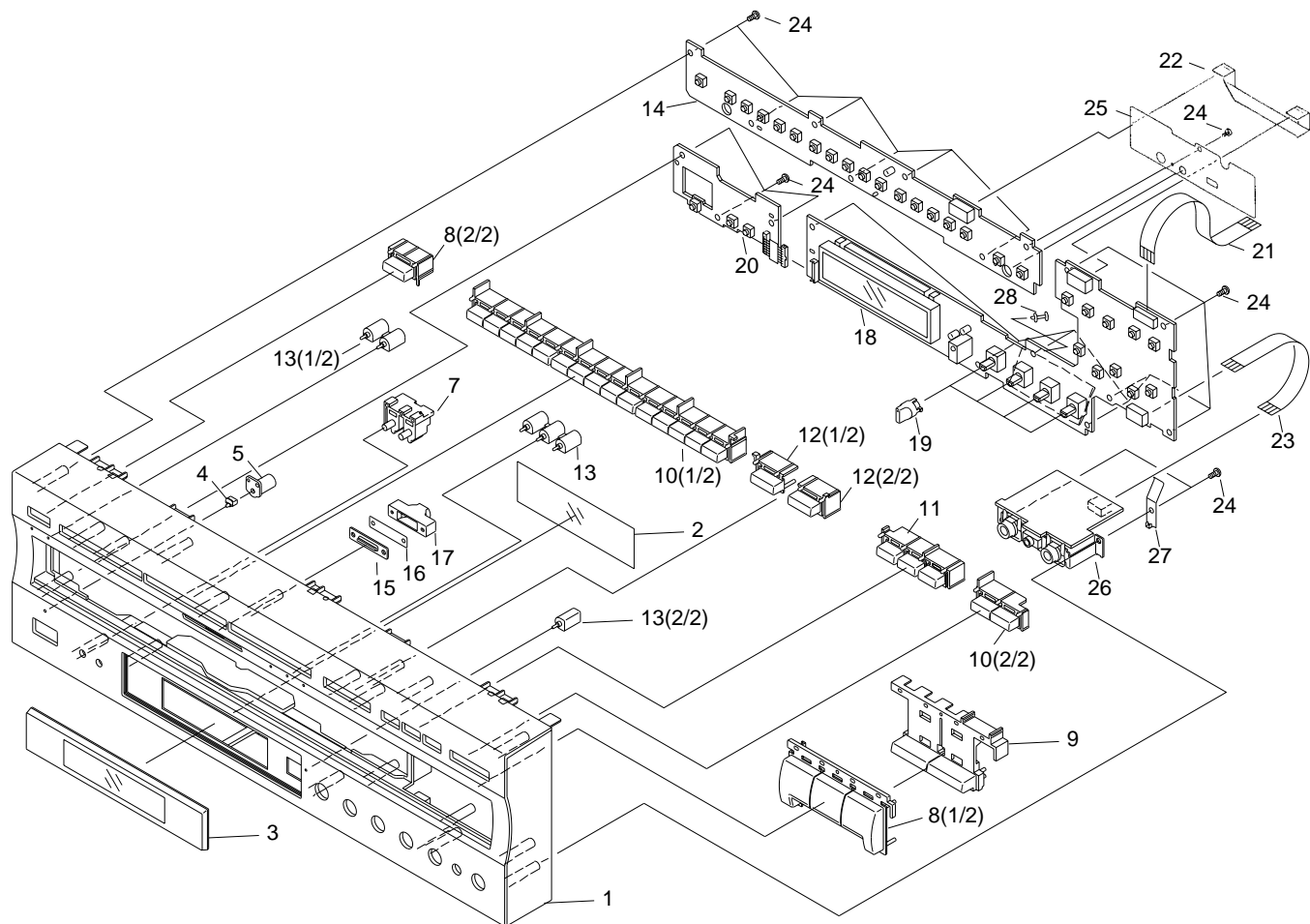

● PARTS LIST

Mark	No.	Description	Part No.	Mark	No.	Description	Part No.
	1	FRONT PANEL	VNK4196		16	ILLUMINATION FILTER	VEC1950
	2	FL FILTER	VEC1722		17	ILLUMI HOLDER	VNK4289
	3	FL LENS	VEC1954		18	FLKY ASSY	VWG1945
	4	LED LENS 1	RNK2066		19	VOLUME KNOB	VNK1733
	5	LENS HOLDER	VNK4151	NSP	20	PWSB ASSY	VWG1947
	6	•••••			21	FLEXIBLE CABLE(14P)	VDA1657
	7	L KEY C	VNK3070		22	FLEXIBLE CABLE(10P)	VDA1655
	8	MAIN KEY	VNK4199		23	FLEXIBLE CABLE(7P)	VDA1656
	9	CTL KEY	VNK4193		24	SCREW	BBZ30P080FMC
	10	17 KEY	VNK4189		25	SHEET F	VEC1972
	11	DVD KEY	VNK4198		26	MICB ASSY	VWV1602
	12	VCD KEY	VNK4197		27	EARTH PLATE	VBK1070
	13	LED LENS	VNK4195	NSP	28	PCB SPACER	AEC1371
	14	KYLB ASSY	VWG1946				
	15	ILLUMINATION LENS	VNK4194				

2.4 TOP VIEW SECTION

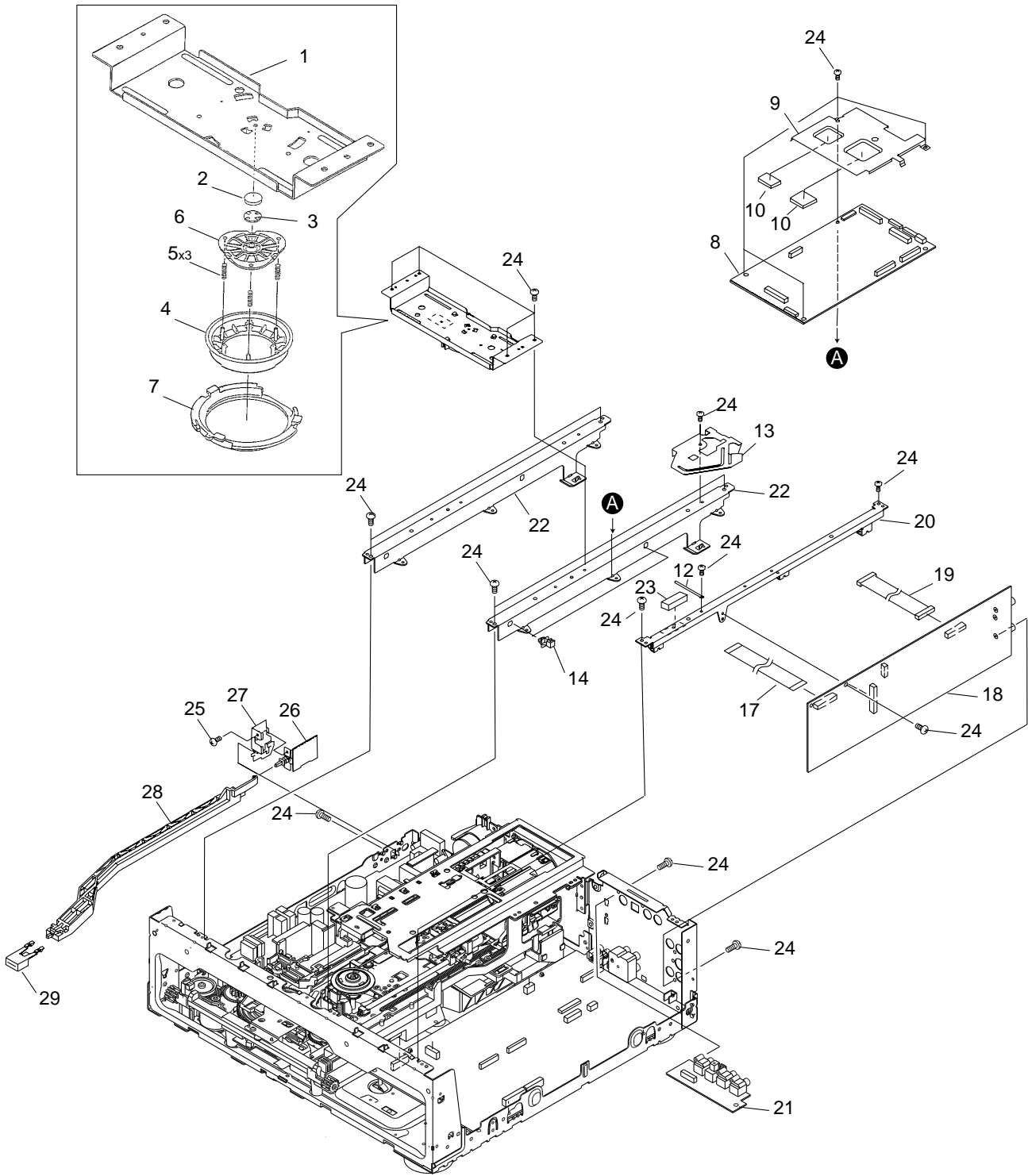

● TOP VIEW SECTION PARTS LIST

Mark	No.	Description	Part No.
	1	CENTER PLATE	VNE2127
	2	RUBBER MAT	VEB1114
	3	THRUST HOLDER	VNL1663
	4	CLAMPER	VNL1648
	5	CLAMPER SPRING	VBH1192
	6	CLAMPER HEAD	VNL1649
	7	CLAMPER HOLDER	VNL1788
	8	DVDM ASSY	VWS1329
	9	HEAT SINK	VNE2134
	10	RADIATION SEAT	VEB1282
	11	•••••	
	12	CORD CLAMPER	RNH-184
	13	CABLE HOLDER	VEC1958
NSP	14	CORNER POST	DEC1212
	15	•••••	
	16	•••••	
	17	FLEXIBLE CABLE(21P)	VDA1658
	18	KYCB ASSY	VWV1599
	19	HOUSING ASSY(13P)	VKP2154
NSP	20	PCB-HOLDER	VNE2121
	21	JCKB ASSY	VWV1580
NSP	22	CENTER ANGLE	VNE2126
	23	CUSION	VEC1982
	24	SCREW	BBZ30P080FMC
	25	SCREW	PMB30P080FZK
	26	MSWB ASSY	VWG1895
NSP	27	POWER HOLDER	VNE2123
	28	POWER JOINT	VNK4148
	29	POWER BUTTON	VNK4184

2.5 BOTTOM VIEW SECTION

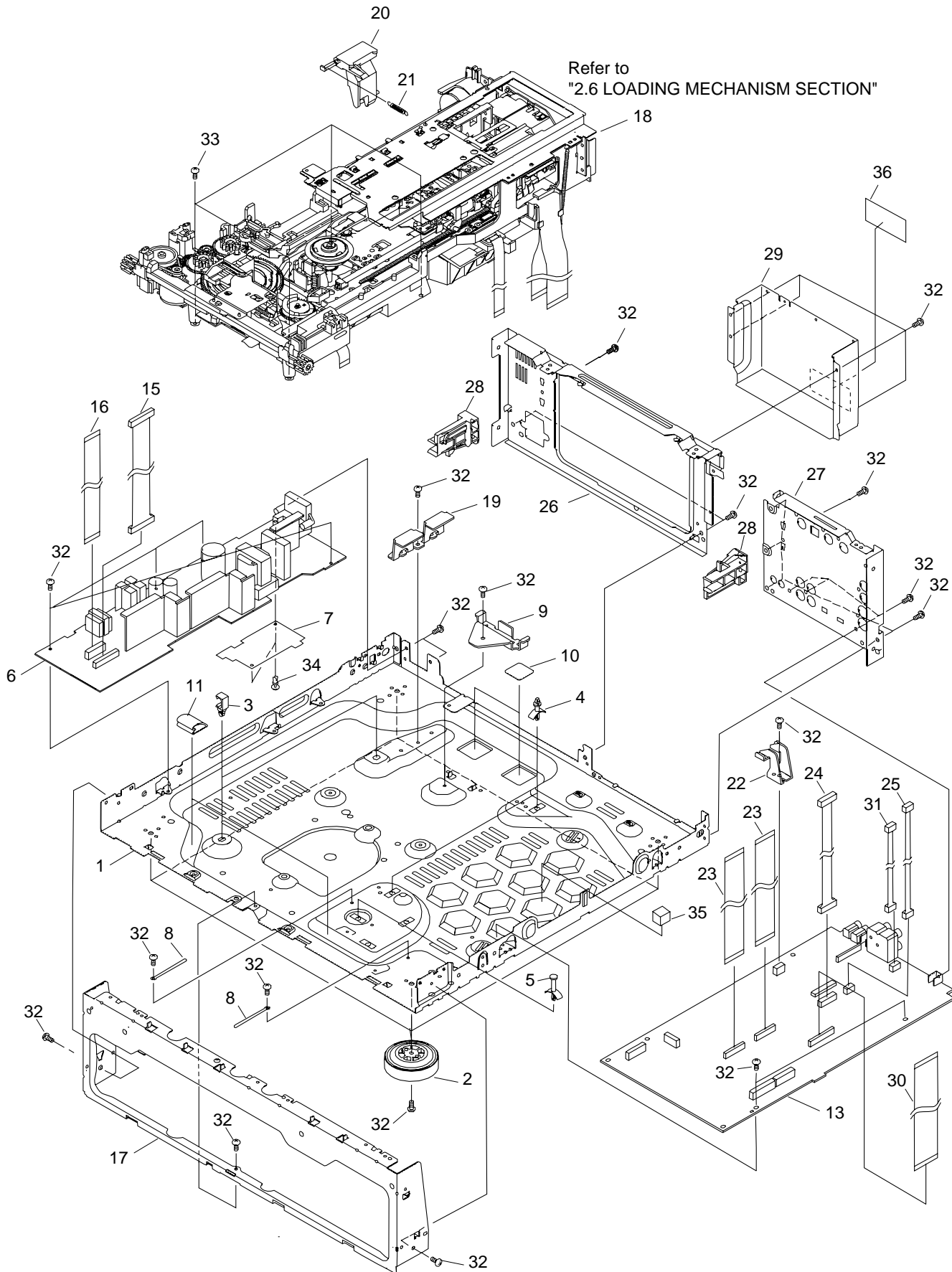

● BOTTOM VIEW SECTION PARTS LIST

Mark	No.	Description	Part No.
NSP	1	CHASSIS	VNA1887
	2	INSULATOR ASSY	VXA2356
	3	PCB HINGE	VEC1174
NSP	4	PCB SPACER	AEC1188
NSP	5	CIRCUIT BOARD SPACER	VEC1957
△	6	POWER SUPPLY ASSY	VWR1287
	7	SHEET P	VEC1874
	8	CORD CLAMPER	RNH-184
NSP	9	STOPPER	VNE2088
	10	SPACER	VEC1939
	11	SHELL CLIP	DEC1184
	12	•••••	
	13	CLDM ASSY	VWS1334
	14	•••••	
	15	HOUSING ASSY (14P)	VKP2151
	16	FLEXIBLE CABLE(15P)	VDA1644
NSP	17	PANEL HOLDER	VNA1686
NSP	18	MECHANISM ASSY	VWT1149
NSP	19	CAM HOLDER L	VNE2089
	20	SHIPPING LEVER	VNL1728
	21	SHIPPING SPRING	VBH1275
NSP	22	CAM HOLDER R	VNE2090
	23	FLEXIBLE CABLE(22P)	VDA1652
	24	HOUSING ASSY (7P)	VKP2155
	25	HOUSING ASSY (4P)	VKP2153
	26	REAR PANEL R	VNA1892
	27	REAR PANEL L	VNA1922
	28	TRAY STOPPER	VNL1707
	29	REAR COVER	VNA1933
	30	FLEXIBLE CABLE(24P)	VDA1659
	31	CONNECTOR ASSY	PF06PP4B20
	32	SCREW	BBZ30P080FMC
	33	SCREW	BBZ30P100FMC
	34	RIVET	RBM-003
NSP	35	SPACER	VEC1989
	36	LABEL(CAUTION)	VRW1699

2.6 LOADING MECHANISM SECTION

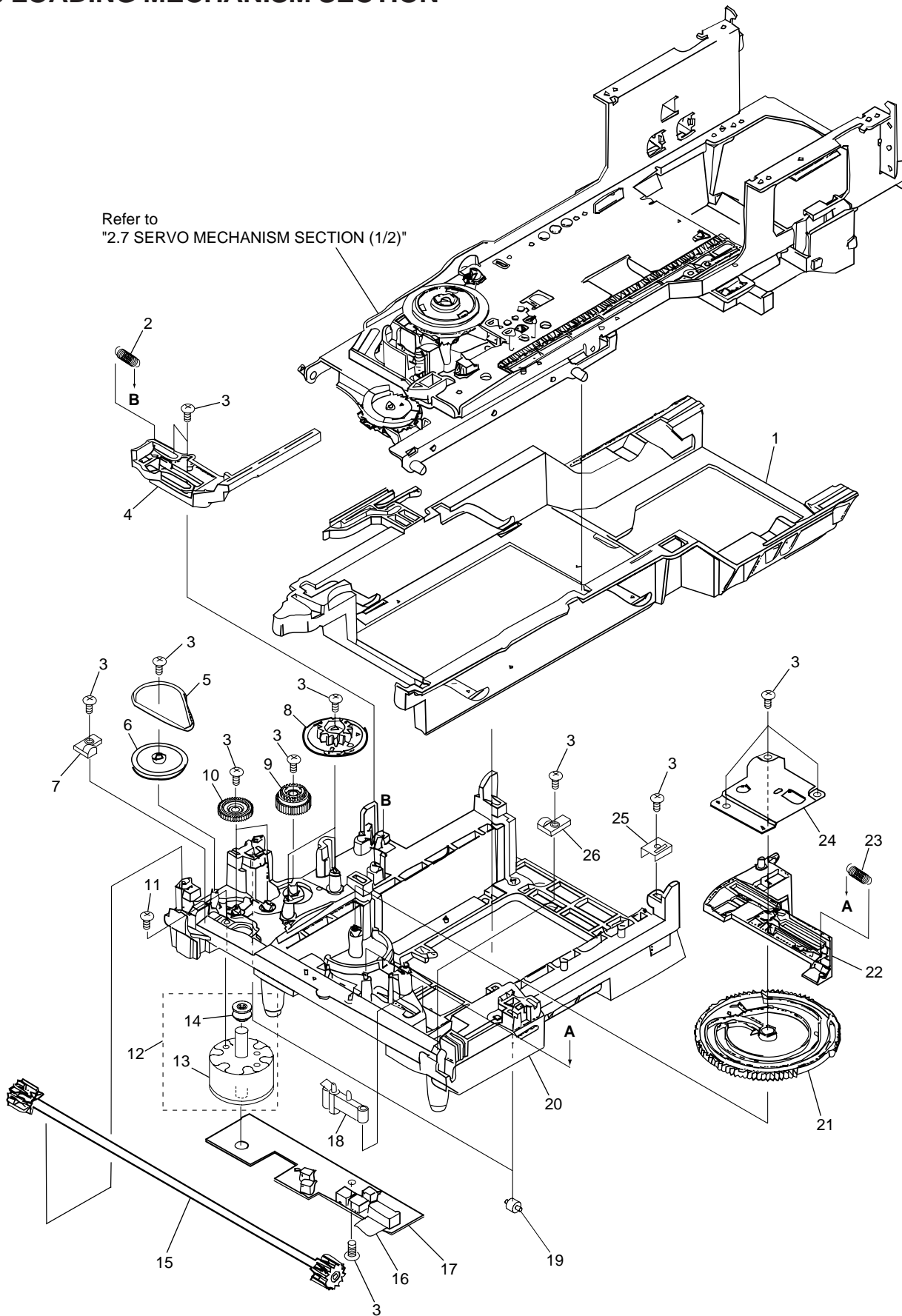

● LOADING MECHANISM SECTION PARTS LIST

Mark	No.	Description	Part No.	Mark	No.	Description	Part No.
	1	Clamp Cam B	VNL1765		16	Flexible Cable (10P)	VDA1645
	2	CDP Spring	VBH1191	NSP	17	LMSB Assy	VWG1554
	3	Screw	Z39-019		18	MB Switch Lever	VNL1664
	4	CD Plate	VNL1685		19	Roller	VNL1042
	5	Rubber Belt	VEB1184		20	Mechanism Base	VNK3239
	6	Gear Pulley	VNL1662		21	Cam Gear	VNL1625
	7	Slider (L)	VNL1665		22	Cam Plate	VNL1631
	8	Twin Gear	VNL1626		23	CAS Spring	VBH1190
	9	Center Gear	VNL1660		24	Shaft Holder	VNE1942
	10	Double Gear	VNL1661		25	CAM Holder	VNE2032
	11	Screw	BMZ26P040FMC		26	Slider (R)	VNL1666
	12	Loading Motor Assy	VXX2045				
	13	Carriage Motor	VXM1033				
NSP	14	Motor Pulley	VNL1630				
	15	Synchro Gear Assy	VXA2105				

2.7 SERVO MECHANISM SECTION (1/2)

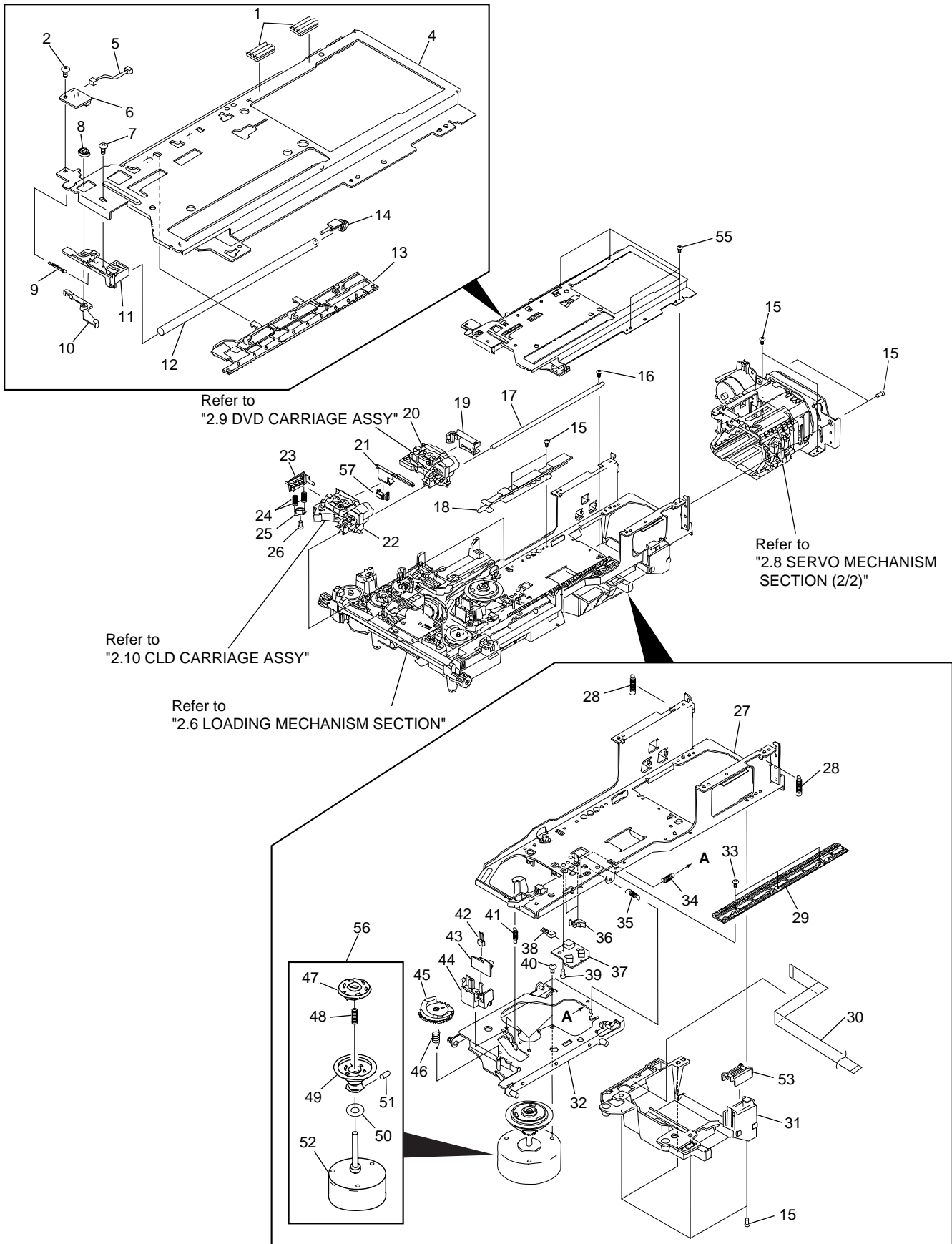

● SERVO MECHANISM SECTION (1/2) PARTS LIST

Mark	No.	Description	Part No.	Mark	No.	Description	Part No.
	1	Mini Clamp	VEC1905		26	Screw	PMZ20P060FZK
	2	Screw	BBZ26P060FMC		27	Tilt Base (Under)	VNL1711
	3	•••••			28	Tilt Rear Spring	VBH1274
	4	Tilt Base (Upper)	VNE2062		29	CA Rack (Lower)	VNL1712
	5	Housing Assy (2P)	VKP2136		30	Flexible Cable (6P)	VDA1642
NSP	6	BISB Assy	VWG1796		31	Flexible Cable Cover	VNL1727
	7	Screw	BPZ20P040FZK		32	Motor Base	VNE1941
	8	B Cam	VNL1725		33	Screw	IBZ26P060FMC
	9	Support Spring	VBH1273		34	Tilt Spring	VBH1263
	10	SW Lever B	VNL1723		35	Thrust Spring	VBH1245
	11	Shaft Holder	VNL1724		36	CA Switch Lever	VNL1644
	12	CA Shaft (Upper)	VLL1486	NSP	37	PKSB Assy	VWG1555
	13	CA Rack (Upper)	VNL1722		38	Housing Assy (3P)	VKP2045
	14	Shaft Stay	VNL1726		39	Screw	IBZ26P120FMC
	15	Screw	BBZ30P080FMC		40	Screw	PMA30P050FMC
	16	Screw	PPZ20P060FMC		41	Tilt Spring B	VBH1287
	17	CA Shaft (Lower)	VLL1496		42	Housing Assy (3P)	VKP2046
	18	TAN Guide	VNE2061	NSP	43	FG Assy	VWG1556
	19	FPC Holder A	VNL1751		44	FG Base	VNL1781
△	20	DVD Carriage Assy	VWT1146		45	Tilt Cam	VNL1643
	21	FPC Holder B	VNL1801		46	Tilt Cam Spring	VBH1243
△	22	CLD Carriage Assy	VWT1141		47	PRC Hub	VNL1684
	23	CA Guide	VNL1668		48	Centering Spring	VBH1269
	24	TAN Spring (B)	VBH1264		49	Turn Table Assy	VXA2354
	25	TAN Lever (B)	VNL1669	NSP	50	Oil Stopper	VBH1002
					51	Screw	ZMD30H030FBT
				NSP	52	Spindle Motor	VXM1057
					53	Cover S	VNL1780
					54	•••••	
					55	Screw	BBZ30P050FZK
					56	Spindle Motor Assy	VXX2521
					57	FPC Holder C	VNL1789

2.8 SERVO MECHANISM SECTION (2/2)

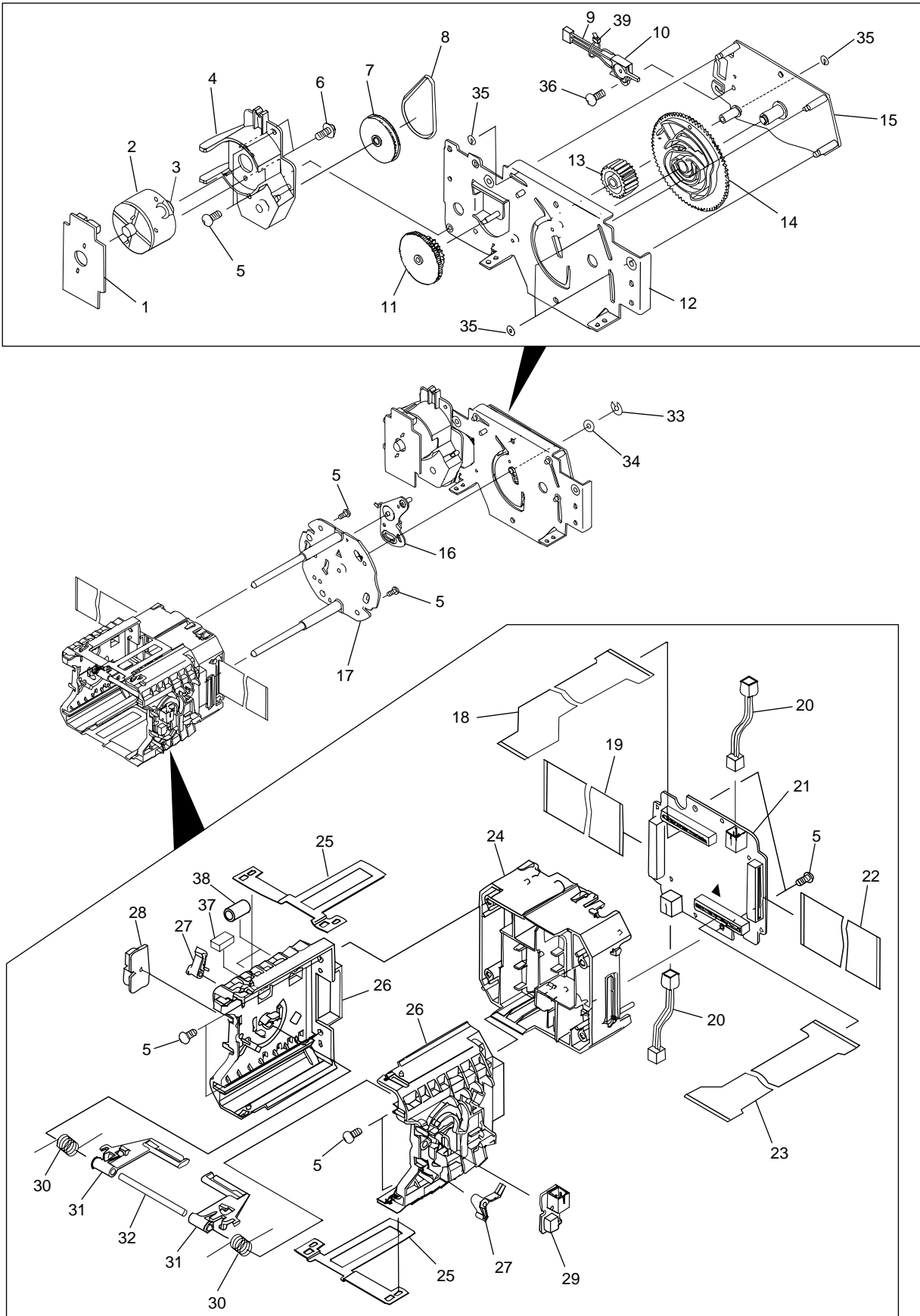

● SERVO MECHANISM SECTION (2/2) PARTS LIST

Mark	No.	Description	Part No.	Mark	No.	Description	Part No.
NSP	1	TNMB Assy	VWG1793	NSP	21	CNNB Assy	VWG1792
	2	Carriage Motor	VXM1033		22	Flexible Cable (27P)	VDA1581
NSP	3	Motor Pulley	VNL1630		23	PU FPC-A	VNP1582
	4	Motor Holder	VNL1717		24	PCB Holder	VNL1716
	5	Screw	BBZ30P080FMC		25	FC Guide	VNE2059
	6	Screw	BMZ26P040FMC		26	PU Holder	VNL1715
	7	Gear Pulley	VNL1662		27	SW Lever C	VNL1714
	8	Rubber Belt	VEB1184	NSP	28	LCSB Assy	VWG1795
	9	Housing Assy (3P)	VKP2137	NSP	29	DCSB Assy	VWG1794
	10	Lever Switch	DSK1003		30	FC Arm Spring	VBH1272
	11	Middle Gear	VNL1720		31	FC Arm	VNL1713
	12	Turn Panel Assy	VXA2337		32	Tilt Shaft	VLL1175
	13	Gear S	VNL1719		33	E Ring	YE30FUC
	14	Turn Cam Gear	VNL1718		34	Washer	WA42D080D050
	15	Swing Plate Assy	VXA2289		35	Washer	WT26D070D050
	16	Turn Lever Assy	VXA2292		36	Screw	PMA26P060FMC
	17	Turn Plate Assy	VXA2290		37	Cushion	VEC1917
	18	PU FPC-B	VNP1583		38	Tube	VEB1273
	19	Flexible Cable (26P)	VDA1653		39	Binder	Z09-056
	20	Connector Assy	PG02KK-E10				

2.9 DVD CARRIAGE ASSY

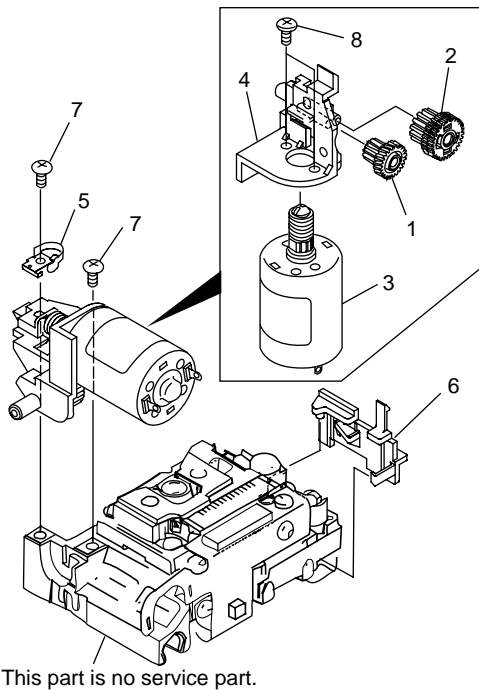

2.10 CLD CARRIAGE ASSY

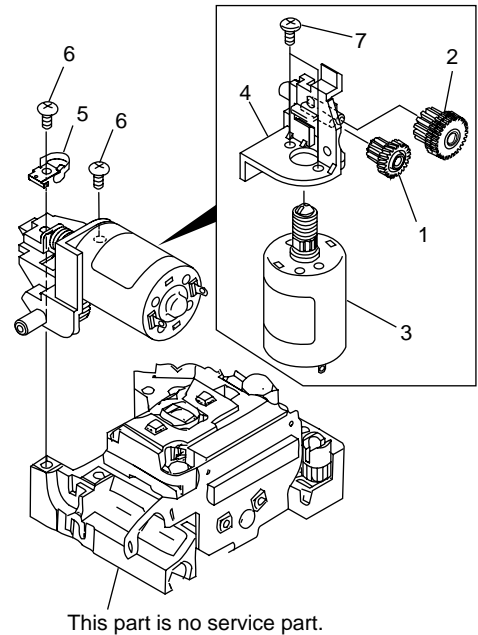

● DVD CARRIAGE ASSY PARTS LIST

Mark	No.	Description	Part No.
	1	CA Gear (A)	VNL1782
	2	CA Gear B Assy	VXX2471
	3	Slider Motor Assy	VXX2472
	4	Motor Holder	VNL1779
	5	Thrust Holder	VBK1058
	6	CA Guide B	VNL1721
	7	Screw	BBZ20P050FZK
	8	Screw	PMA20P033FMC

● CLD CARRIAGE ASSY PARTS LIST

Mark	No.	Description	Part No.
	1	CA Gear (A)	VNL1782
	2	CA Gear (B)	VNL1639
	3	Slider Motor Assy	VXX2472
	4	Motor Holder	VNL1779
	5	Thrust Holder	VBK1058
	6	Screw	PBZ20P050FMC
	7	Screw	PMZ20P030FMC

3. SCHEMATIC DIAGRAM

3.1 OVERALL WIRING DIAGRAM, LMSB, PKSB, FG, CNNB, TNMB, DCSB, LCSB AND BISB ASSEMBLIES

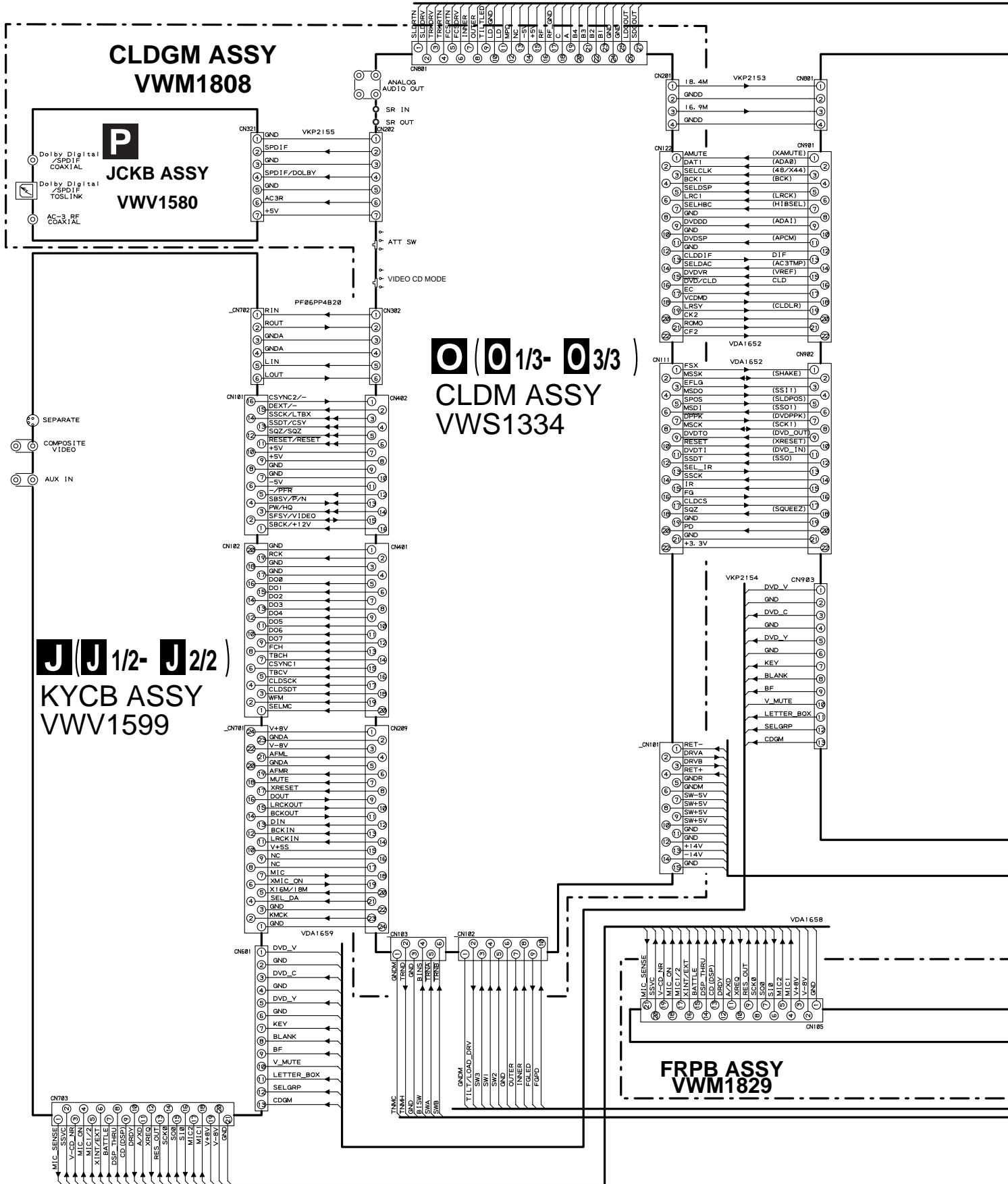

Note : When ordering service parts, be sure to refer to "EXPLODED VIEWS and PARTS LIST" or "PCB PARTS LIST".

- ➔ : RF SIGNAL ROUTE
- Ⓜ : FOCUS SERVO LOOP LINE
- Ⓝ : TRACKING SERVO LOOP LINE
- Ⓞ : SLIDER SERVO LOOP LINE

I (**I** 1/3- **I** 3/3)
DVDM ASSY
VWS1329

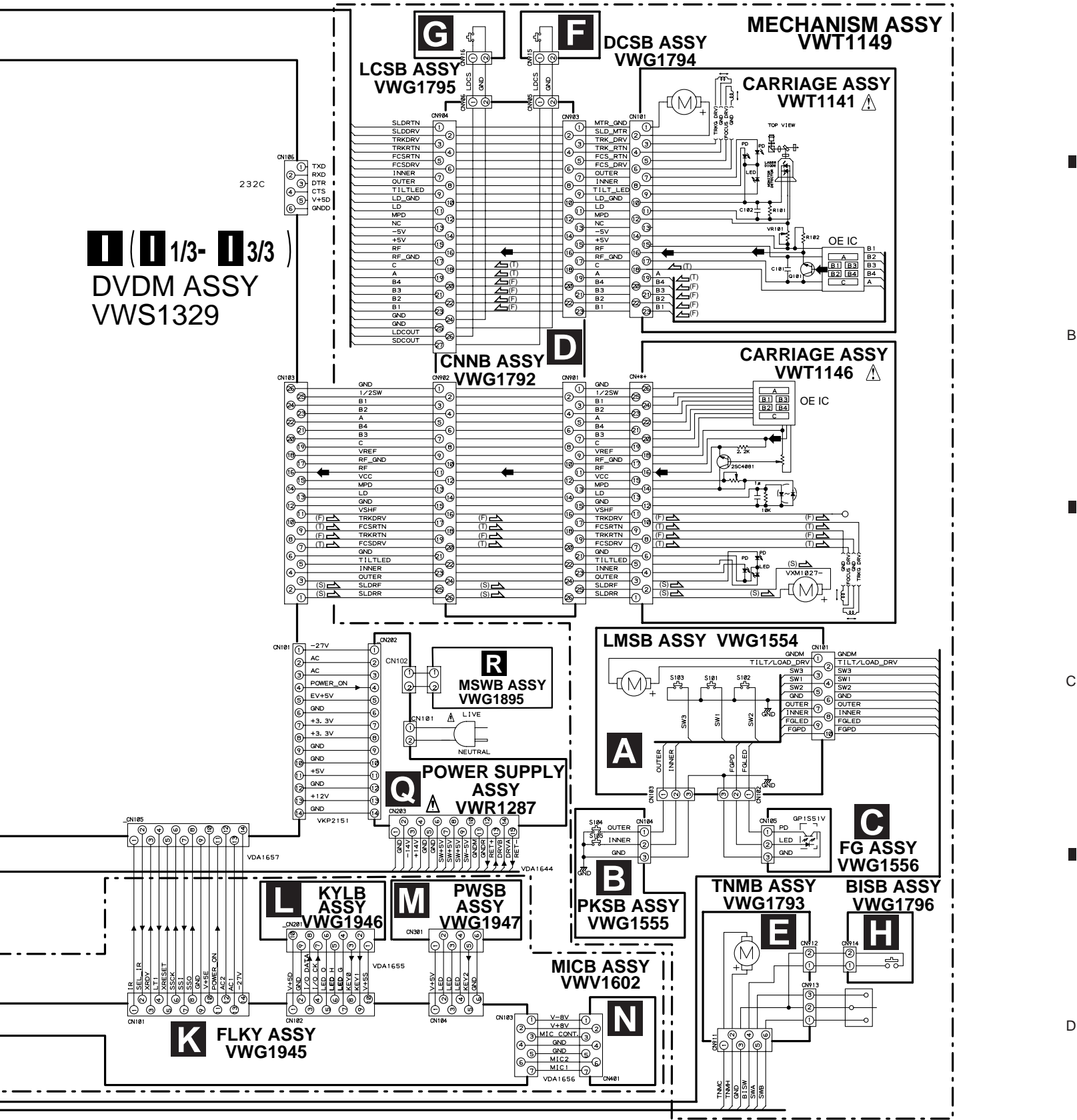

A B C D E F G H

IC501:MECHANISM CONTROL
MICROCOMPUTER for DVD

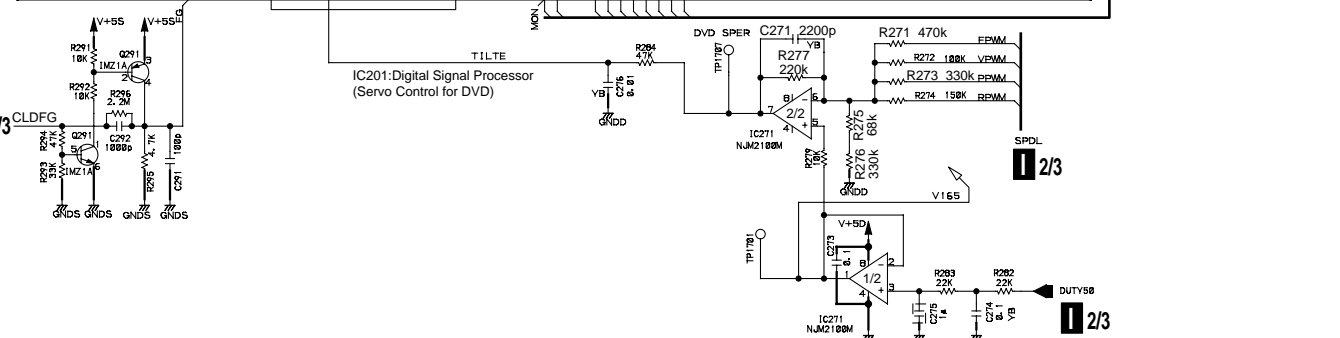
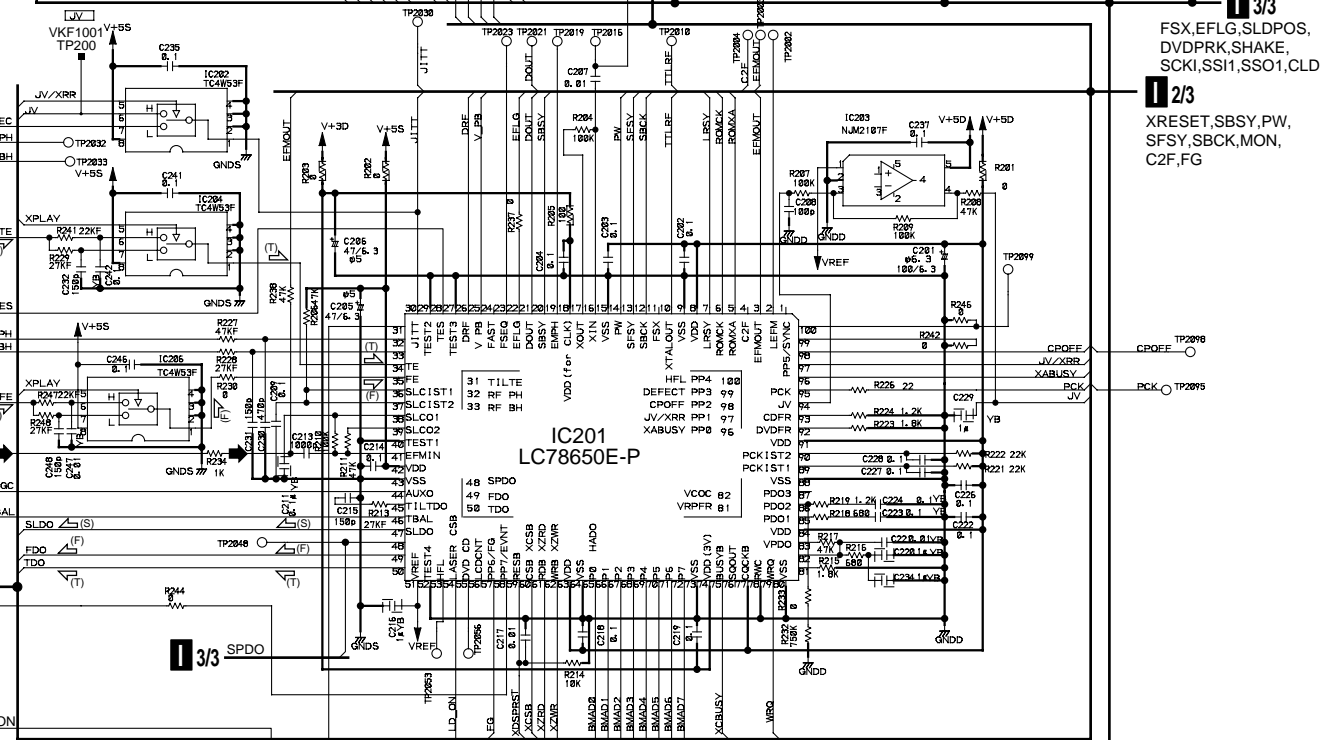
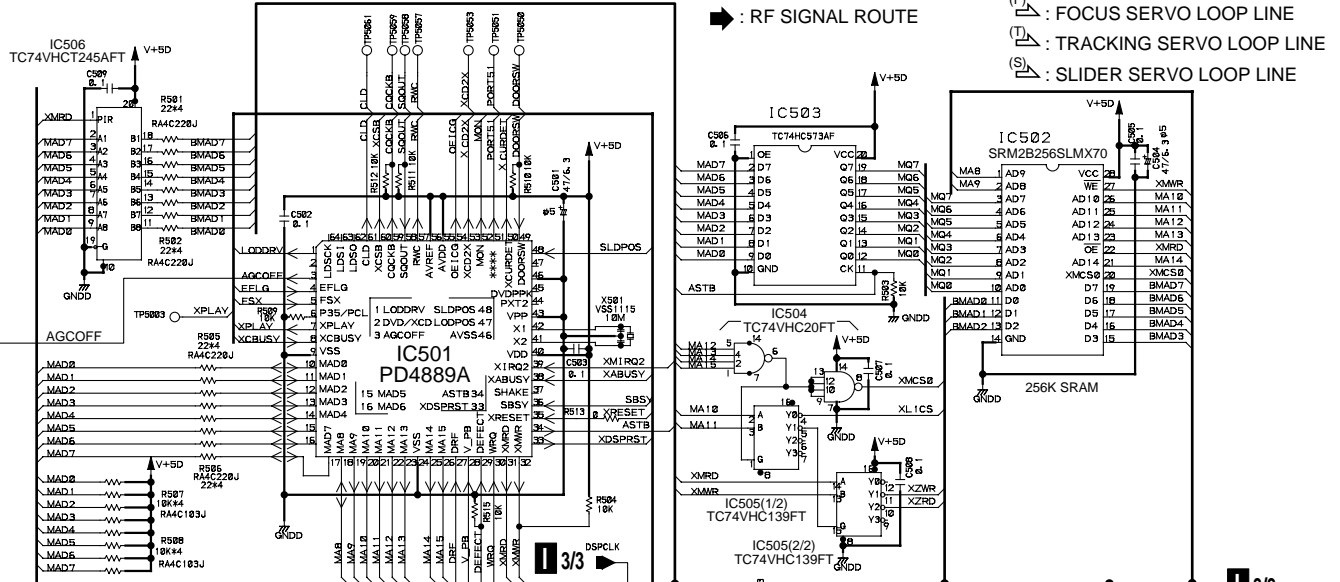

3.3 DVDM ASSY (2/3)

A

B

C

D

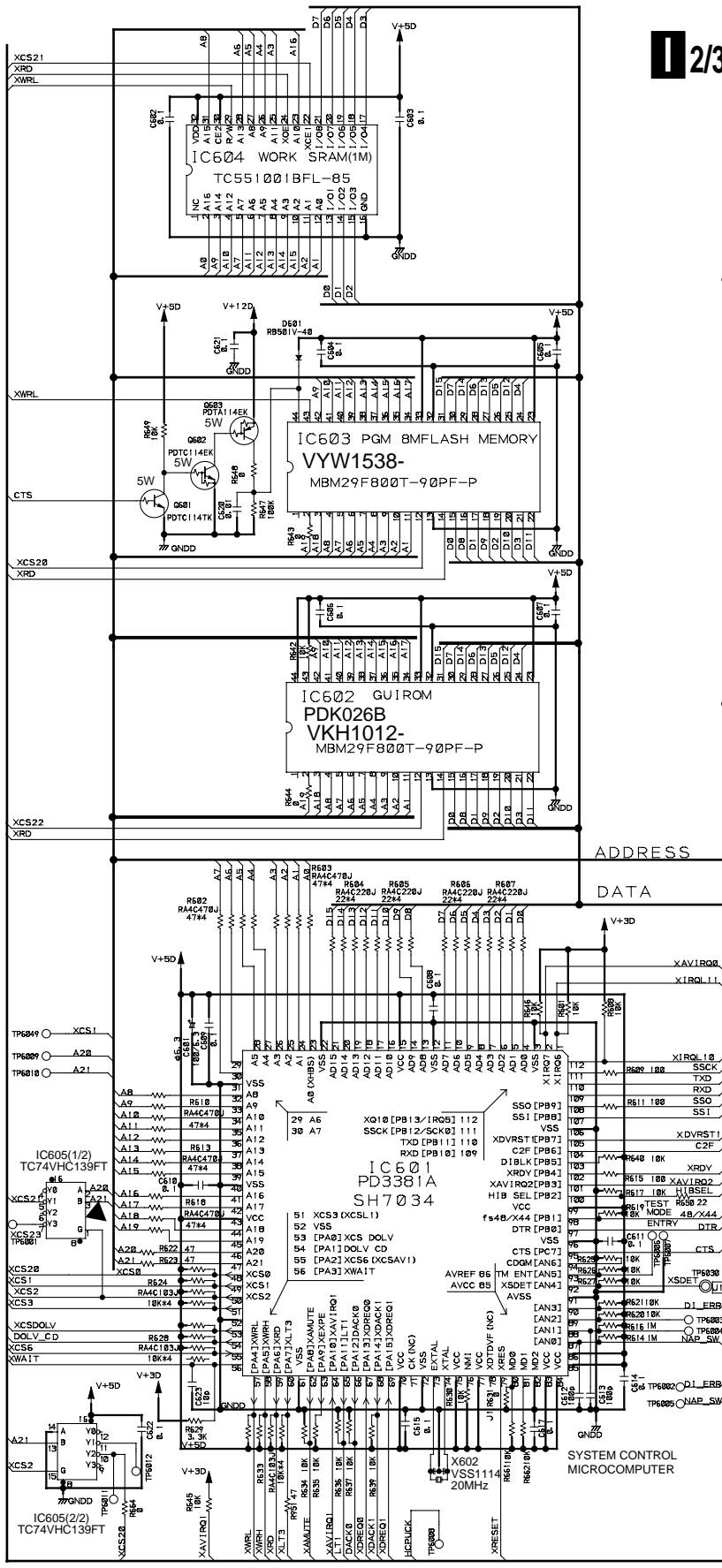

2/3 DVDM ASSY
VWS1329

1/3
C2F.XRESET

3/3
XCSDOLV,DOLV-CD,XWRL,XWRH,
XRD,XLT3,XAMUTE,XDREQ1,CDGM,
HCPUCK,IR,SEL-IR,XDVRST1,
XAVIRQ0,48/X44,HIBSEL,XCS6,
XDACK1,NAP SW,C2F

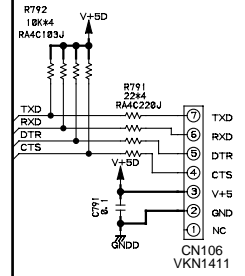

MAIN

3/3
ADDRESS
A2-A10

3/3
DATA

1/3

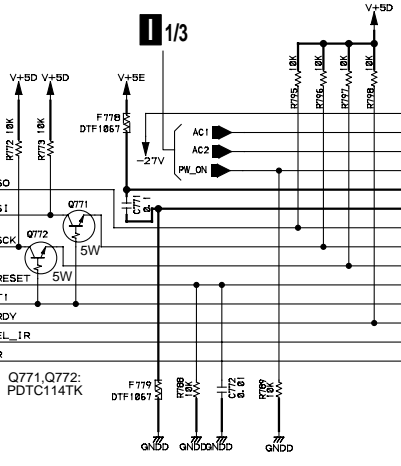

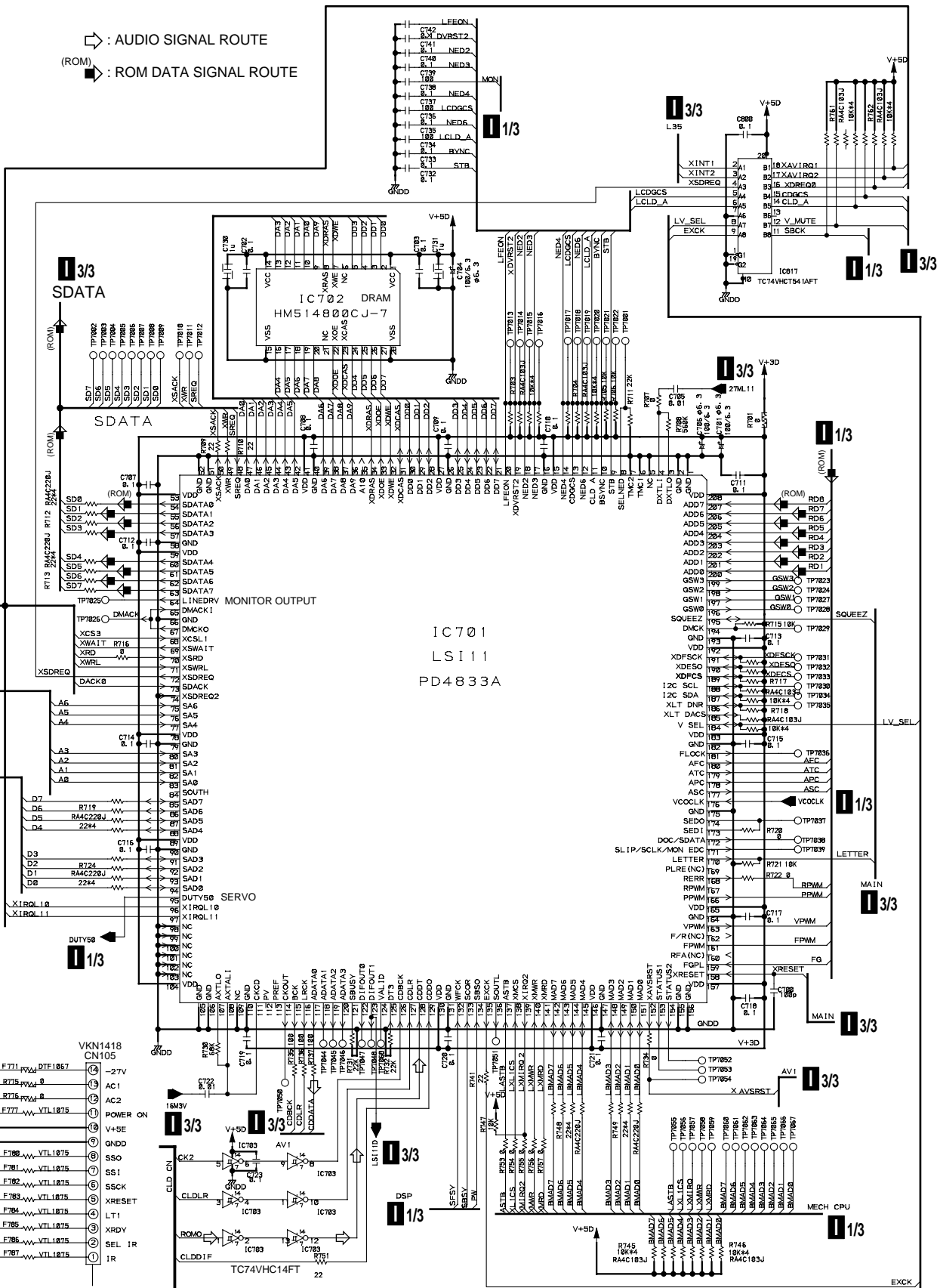

↗ : AUDIO SIGNAL ROUTE
 (ROM) ↘ : ROM DATA SIGNAL ROUTE

3/3

3/3

3/3

3/3

3/3

3/3

3/3

3/3

K
CN101

1/3

1/3

1/3

1/3

1/3

1/3

1/3

1/3

1/3

1/3

3/3

3/3

3/3

3/3

3/3

3/3

3/3

3/3

3/3

3/3

1/3

1/3

1/3

1/3

1/3

1/3

1/3

1/3

1/3

2/3

3.4 DVDM ASSY (3/3)

3/3 DVDM ASSY VWS1329

A

B

C

D

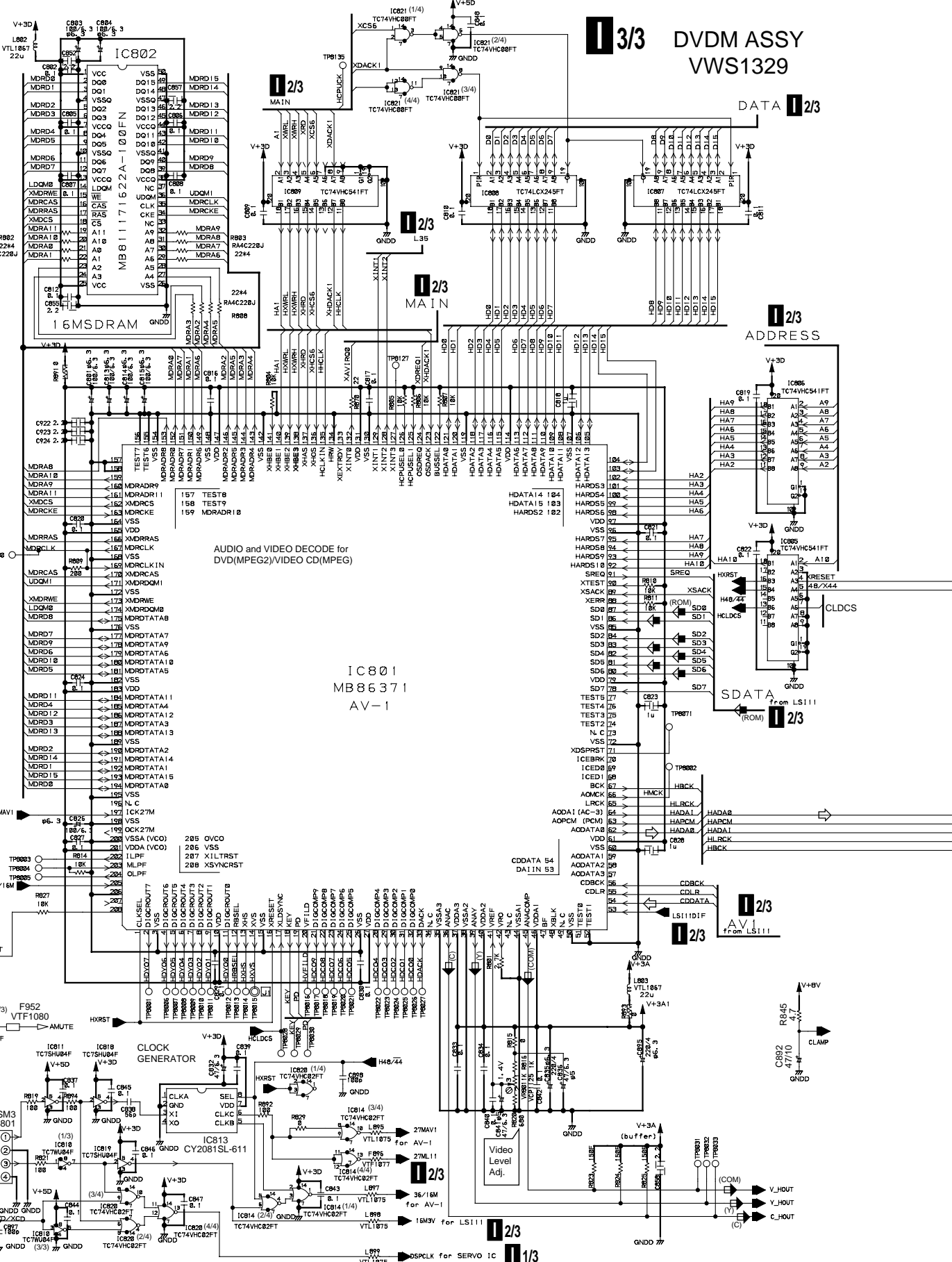

- ◁ : AUDIO SIGNAL ROUTE
- (ROM) ◁ : ROM DATA SIGNAL ROUTE
- (COM) ◁ : COMPOSITE VIDEO SIGNAL ROUTE
- (Y) ◁ : Y SIGNAL ROUTE
- (C) ◁ : C SIGNAL ROUTE

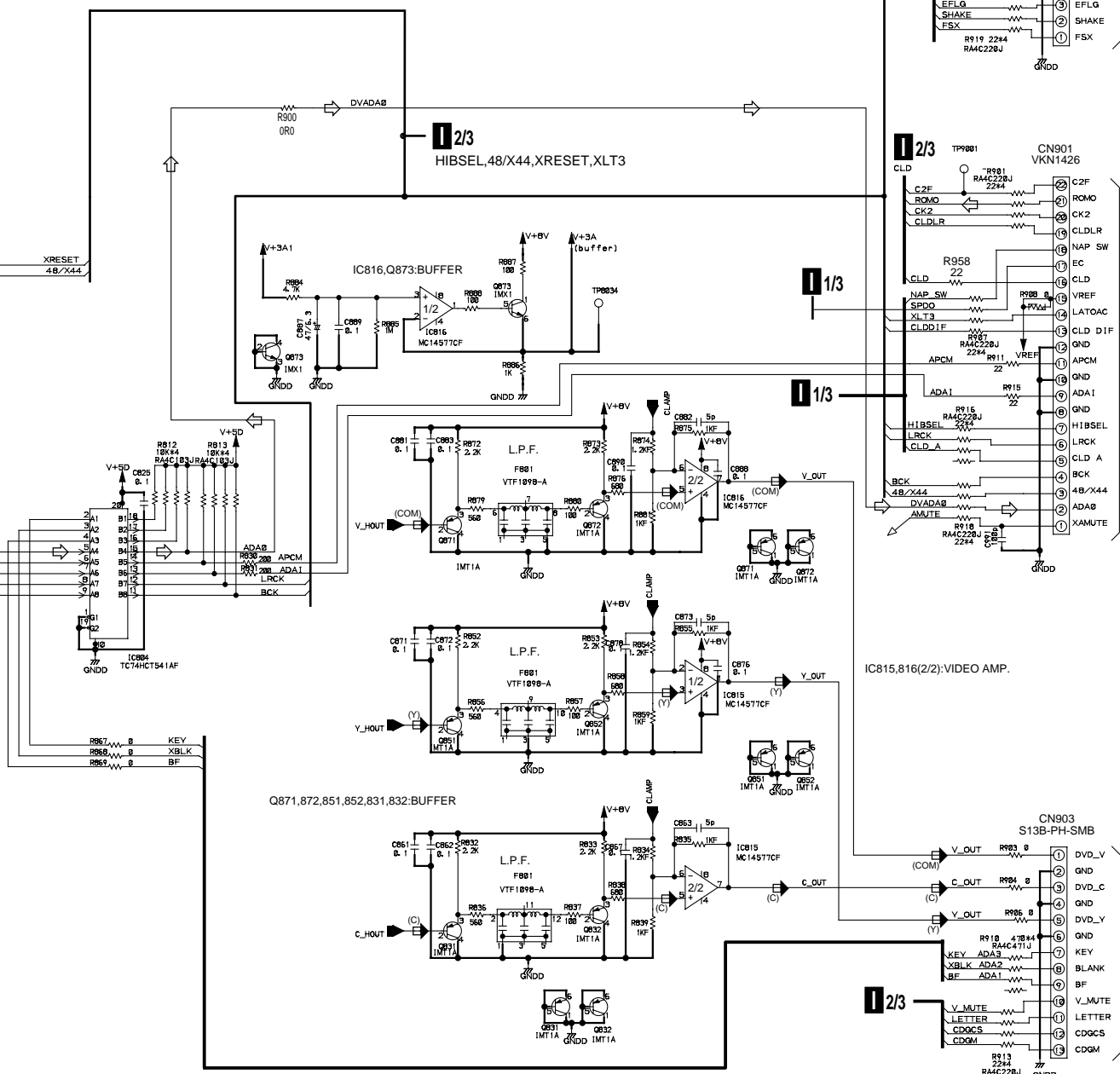
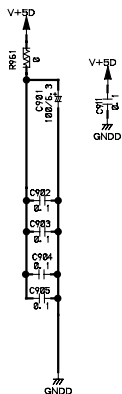

1/3 CN111

2/3 CN122

2/2 CN601

J1/2 KYCB ASSY(1/2)
VWV1599

SIGNAL ROUTE
(V) : VIDEO SIGNAL ROUTE
(Y) : Y SIGNAL ROUTE
(C) : C SIGNAL ROUTE

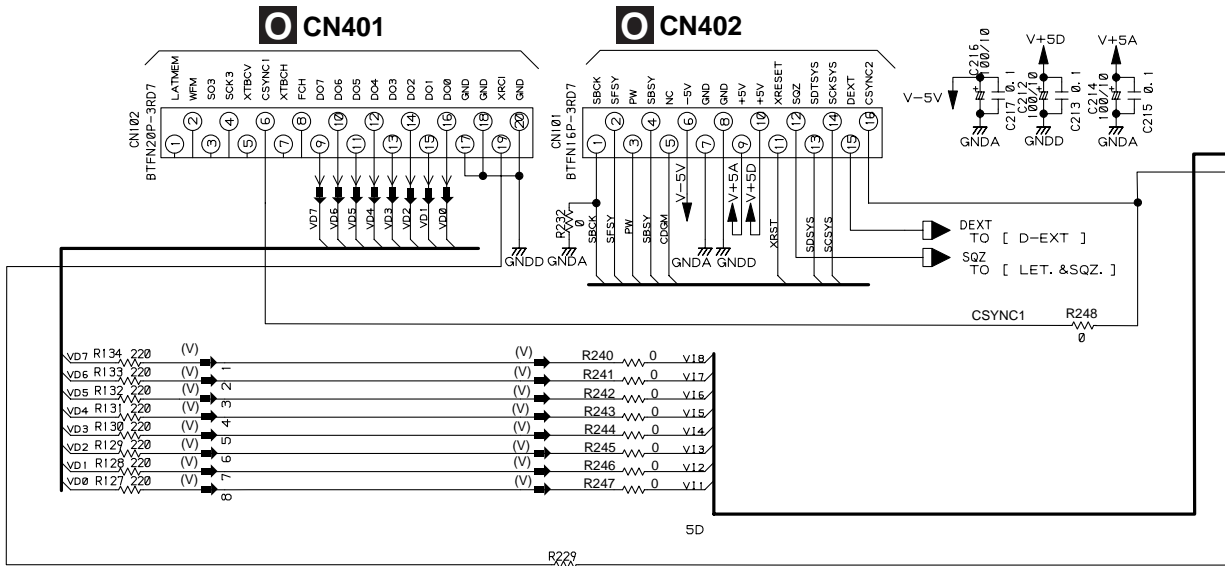

[LD-G]

[DVD/LD SELECT
V-CD NR ON/OFF]

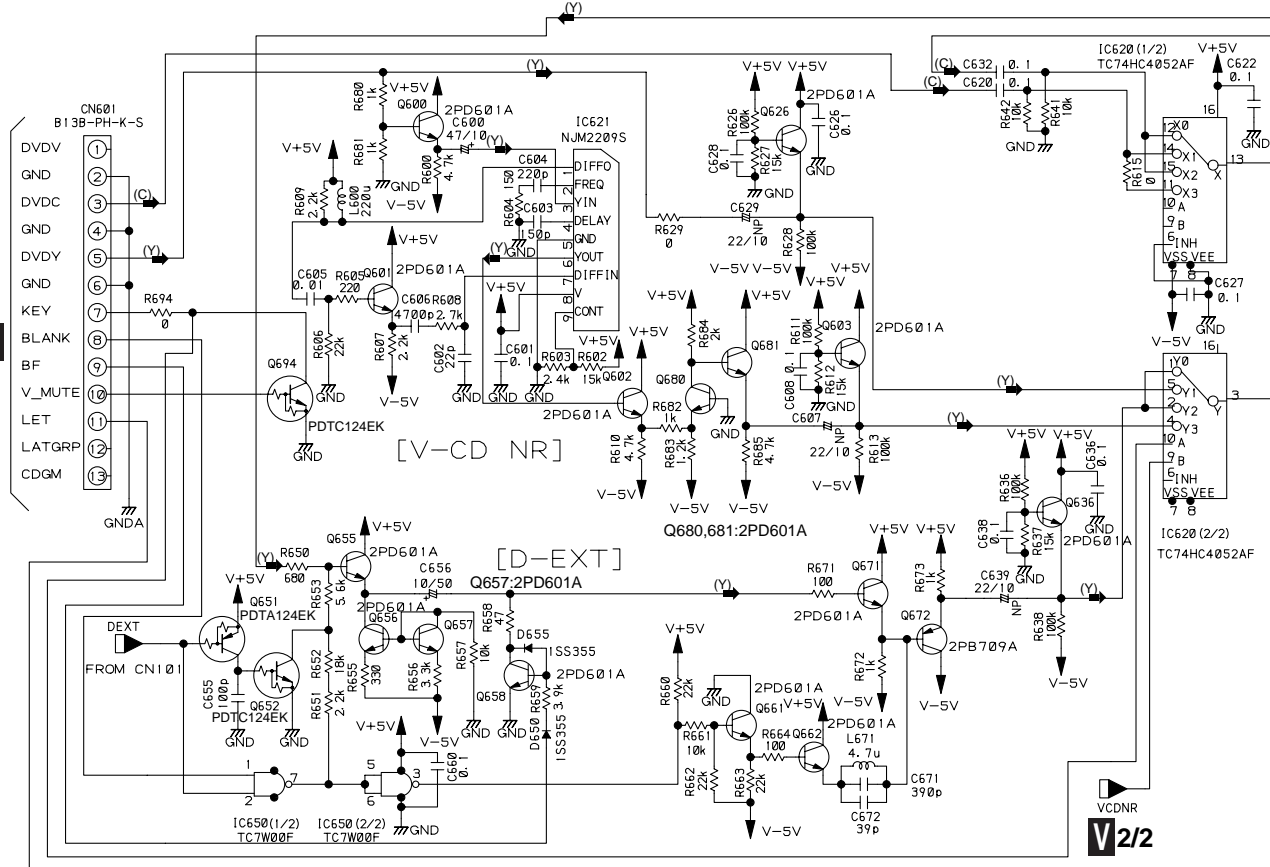

VCDNR
V2/2

3.6 KYCB ASSY (2/2)

A

B

C

D

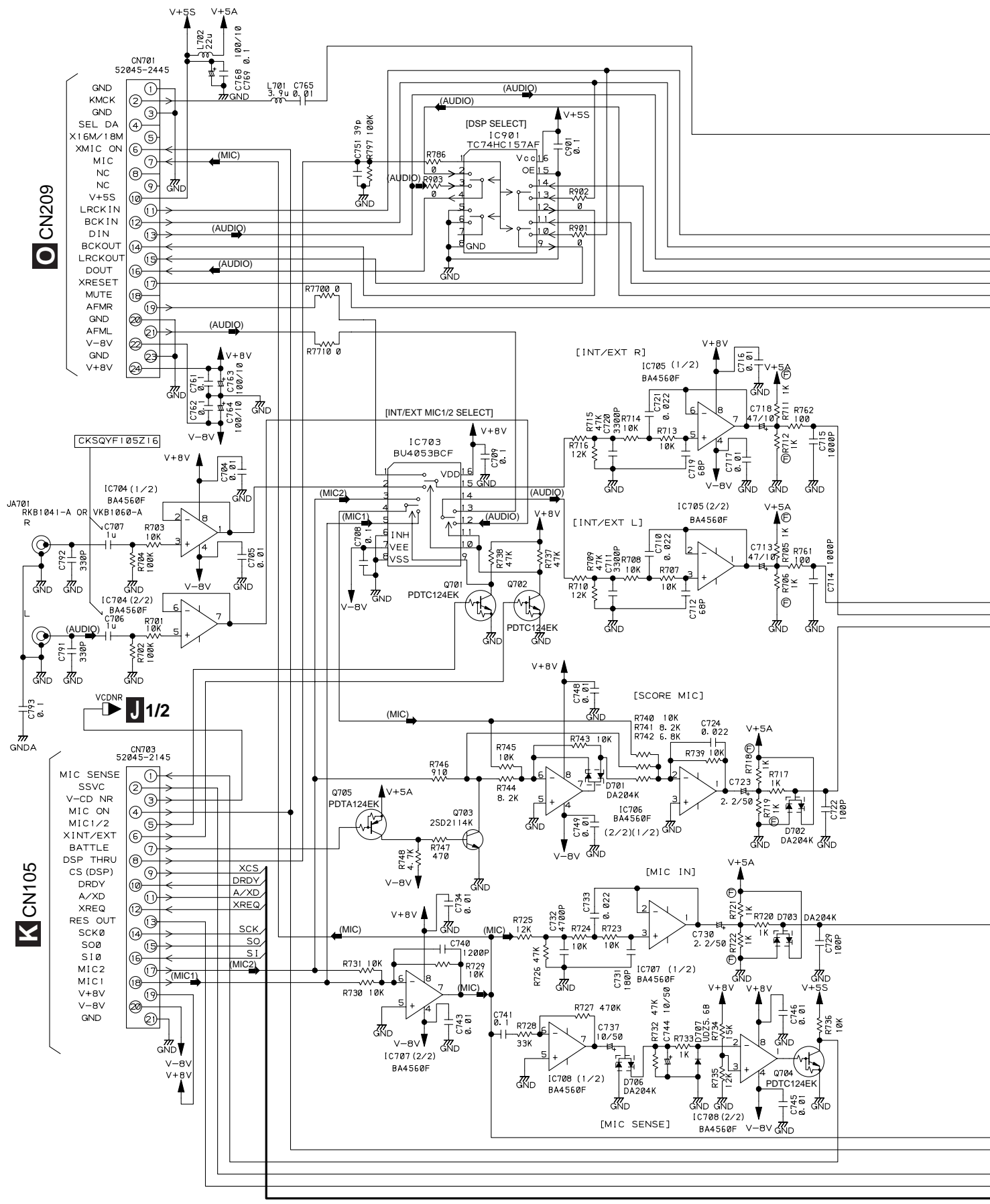

J2/2 KYCB ASSY(2/2) VWV1599

SIGNAL ROUTE
(MIC): AUDIO SIGNAL LIN(MIC)
(AUDIO): AUDIO SIGNAL LIN(AUDIO)

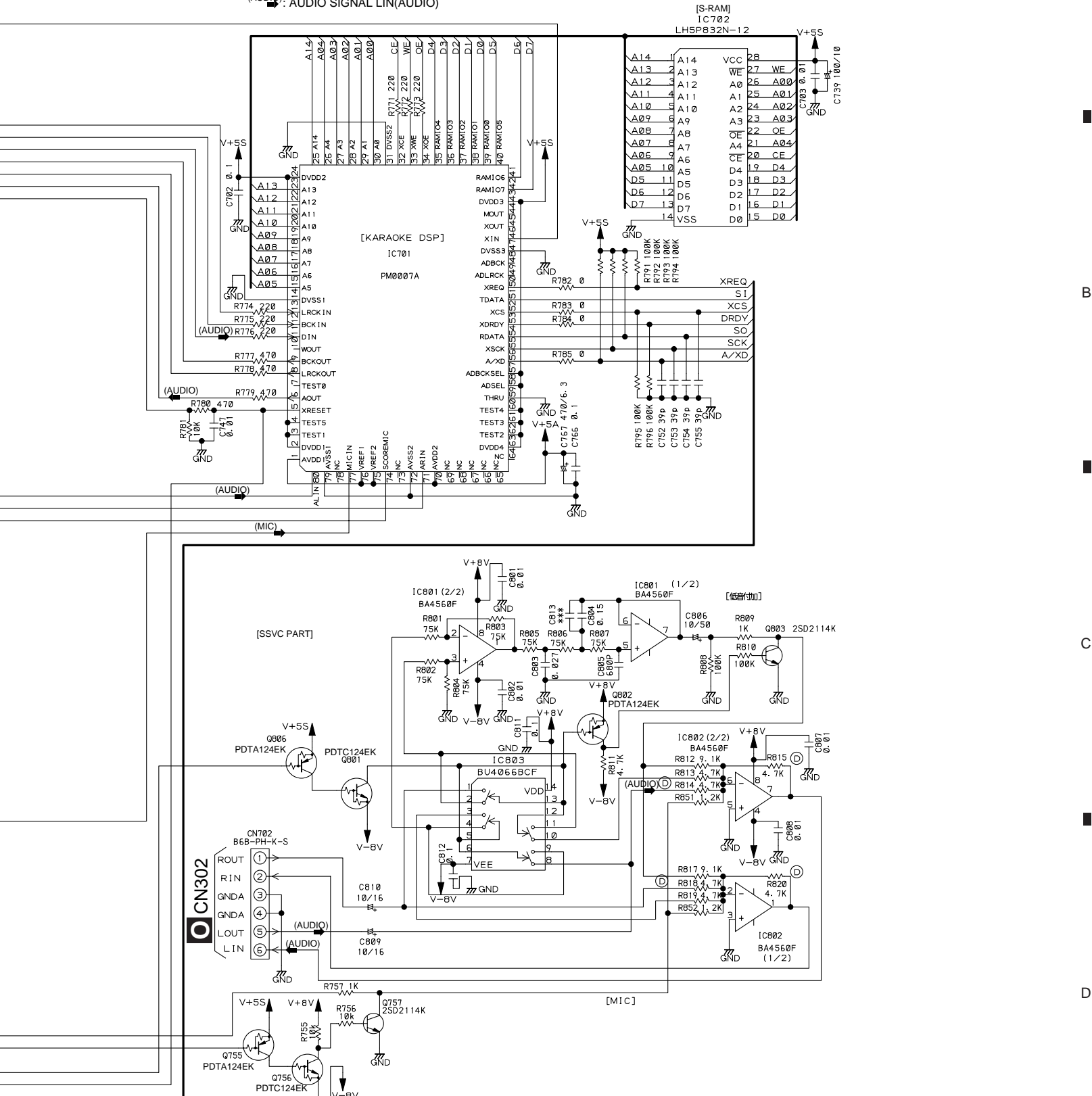

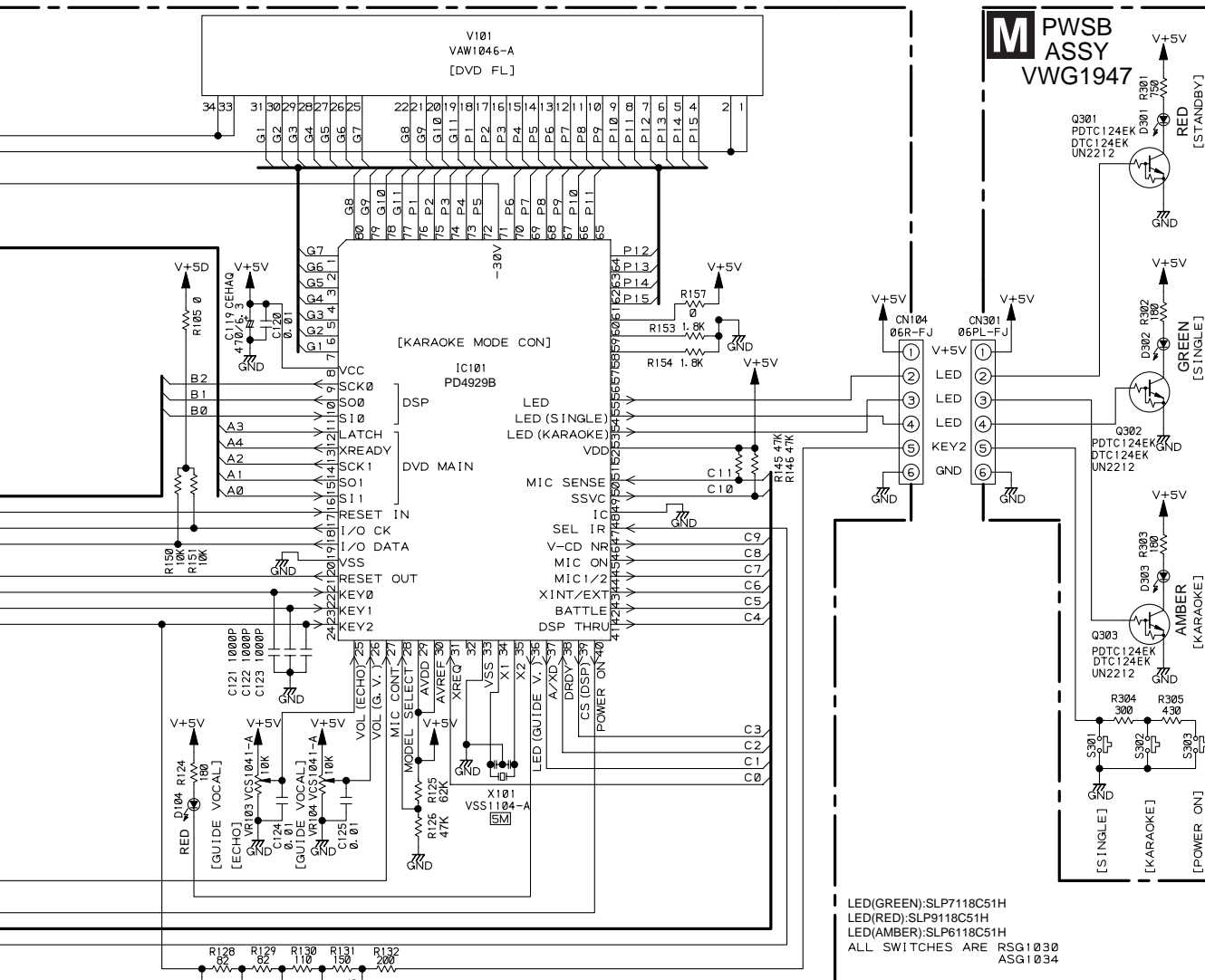
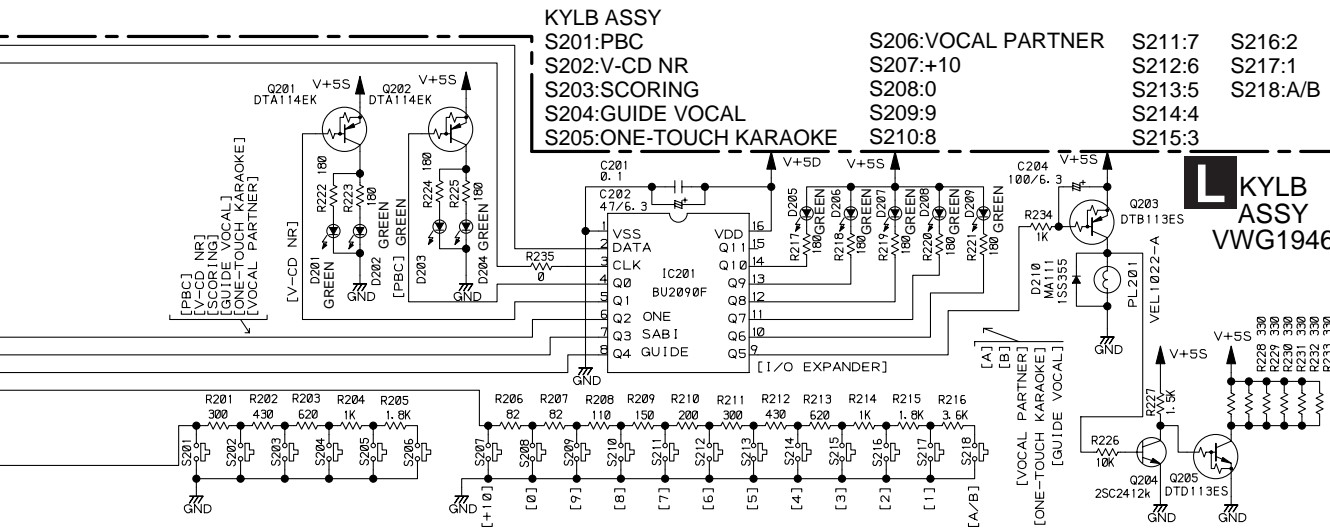

LED(GREEN):SLP7118C51H
 LED(RED):SLP9118C51H
 LED(AMBER):SLP6118C51H
 ALL SWITCHES ARE RSG1030
 ASG1034



3.8 CLDM ASSY (1/3)

A

B

C

D

02/3

03/3

AUDIO CIRCUIT

VIDEO CIRCUIT

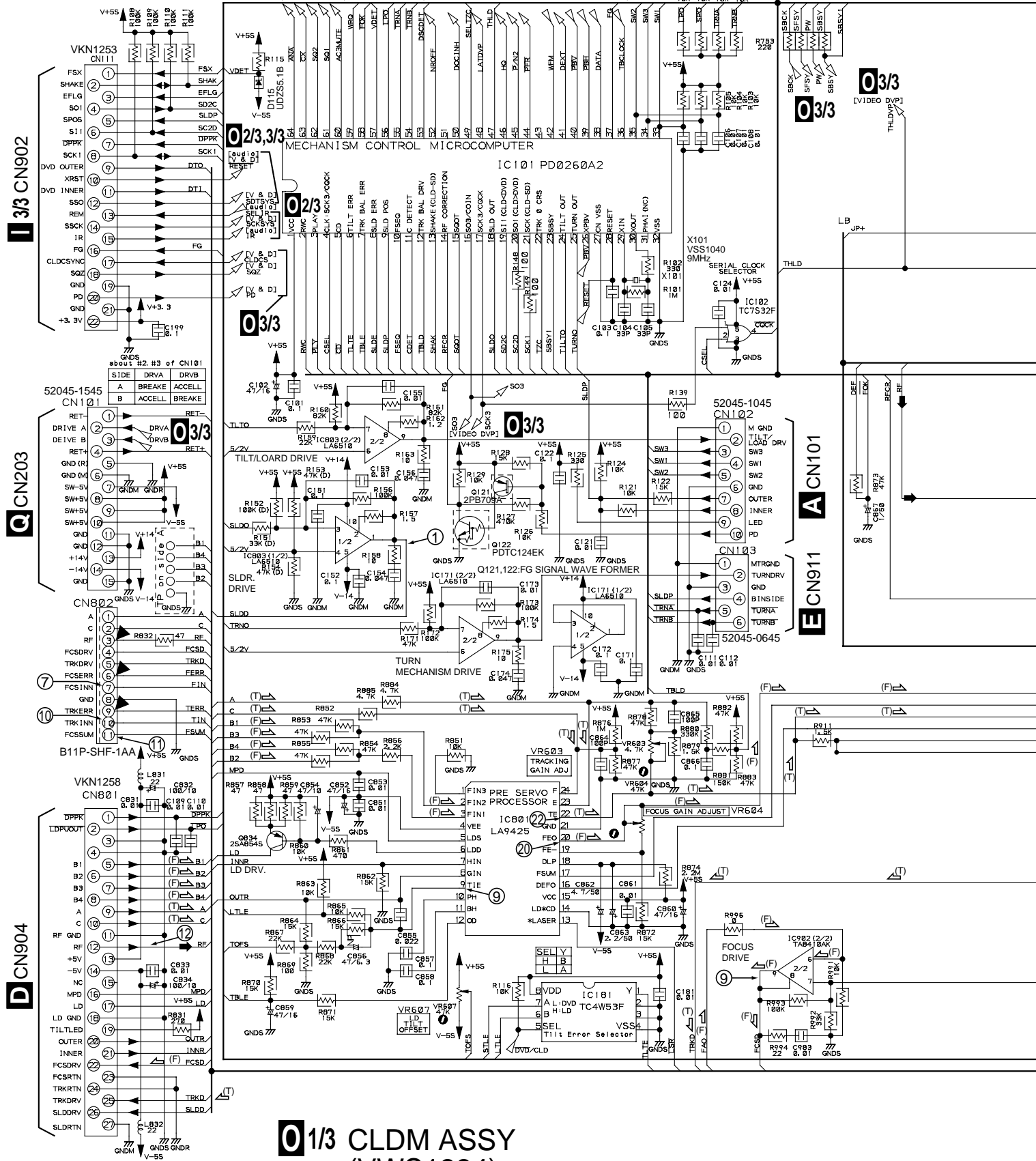

01/3 CLDM ASSY (VWS1334)

01/3

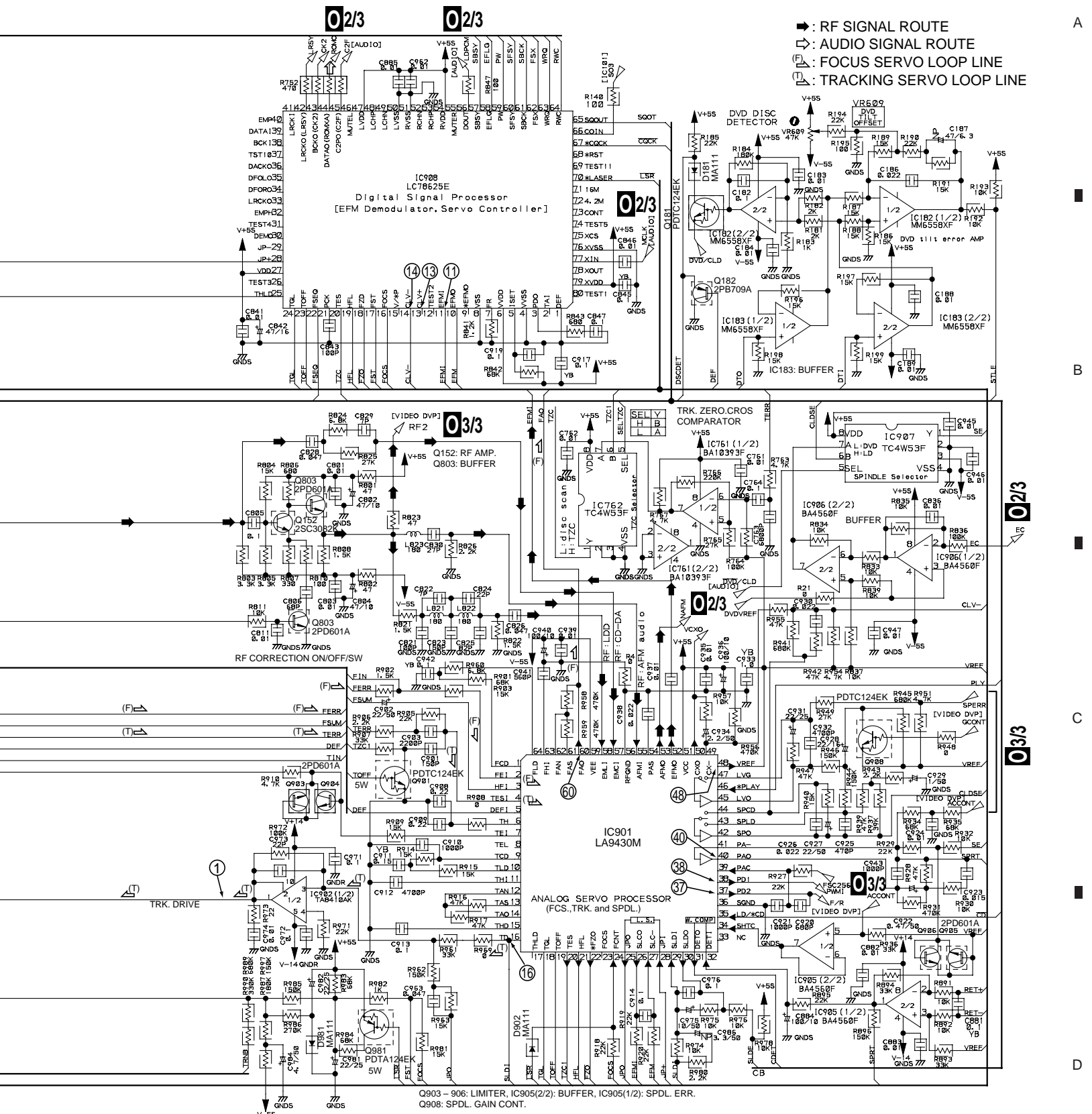

● WAVEFORMS AND VOLTAGES

Note : (No.) in the table correspond to the pin number.

Measurement condition : In case when (D.audio) is written, at time when disc that has digital audio recording is played.

📌 CLDM ASSY

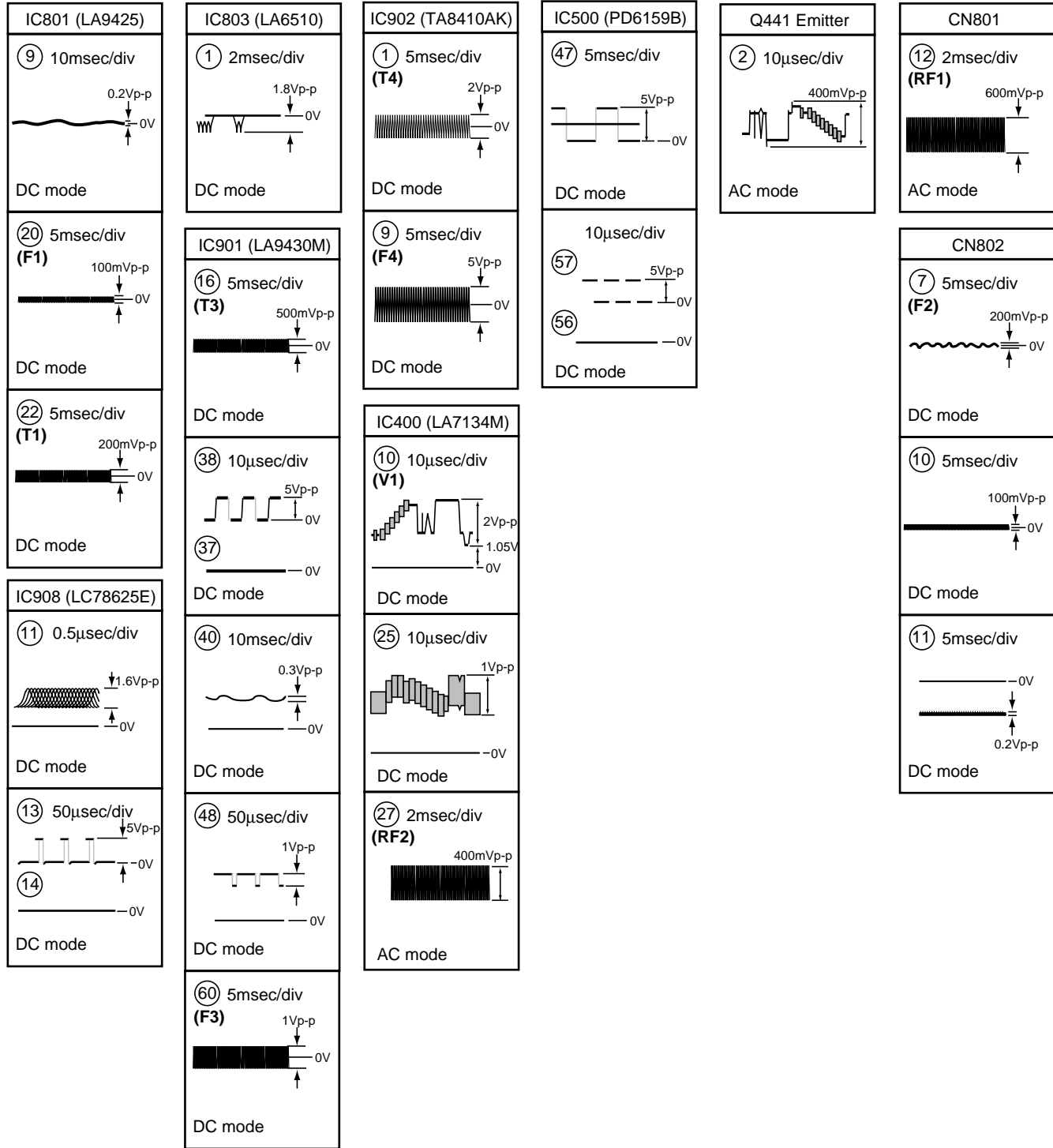

3.9 CLDM ASSY (2/3) AND JCKB ASSY

A

B

C

D

0 1/3

0 1/3

0 3/3

0 1/3

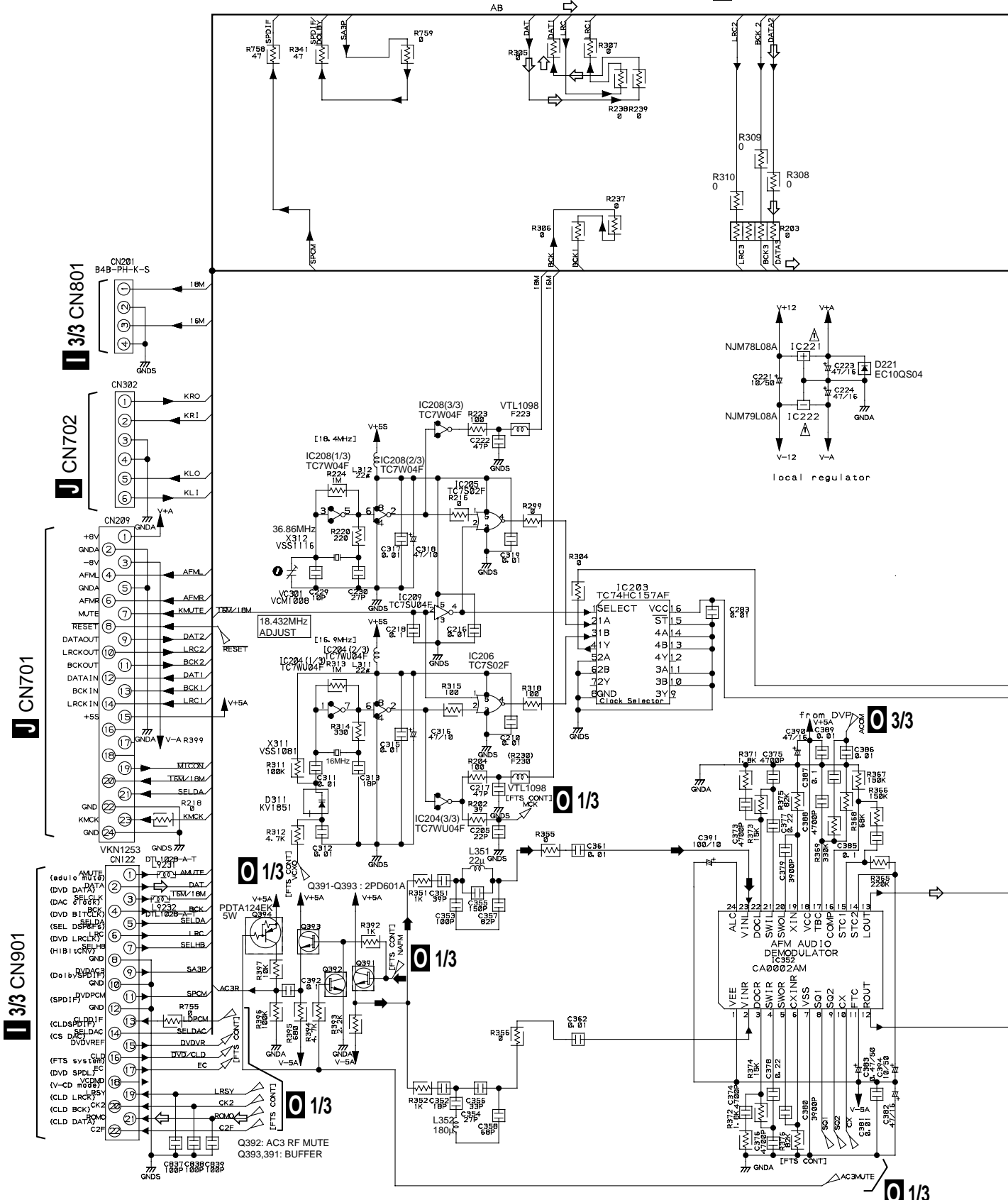

3.11 POWER SUPPLY ASSY

A

B

C

D

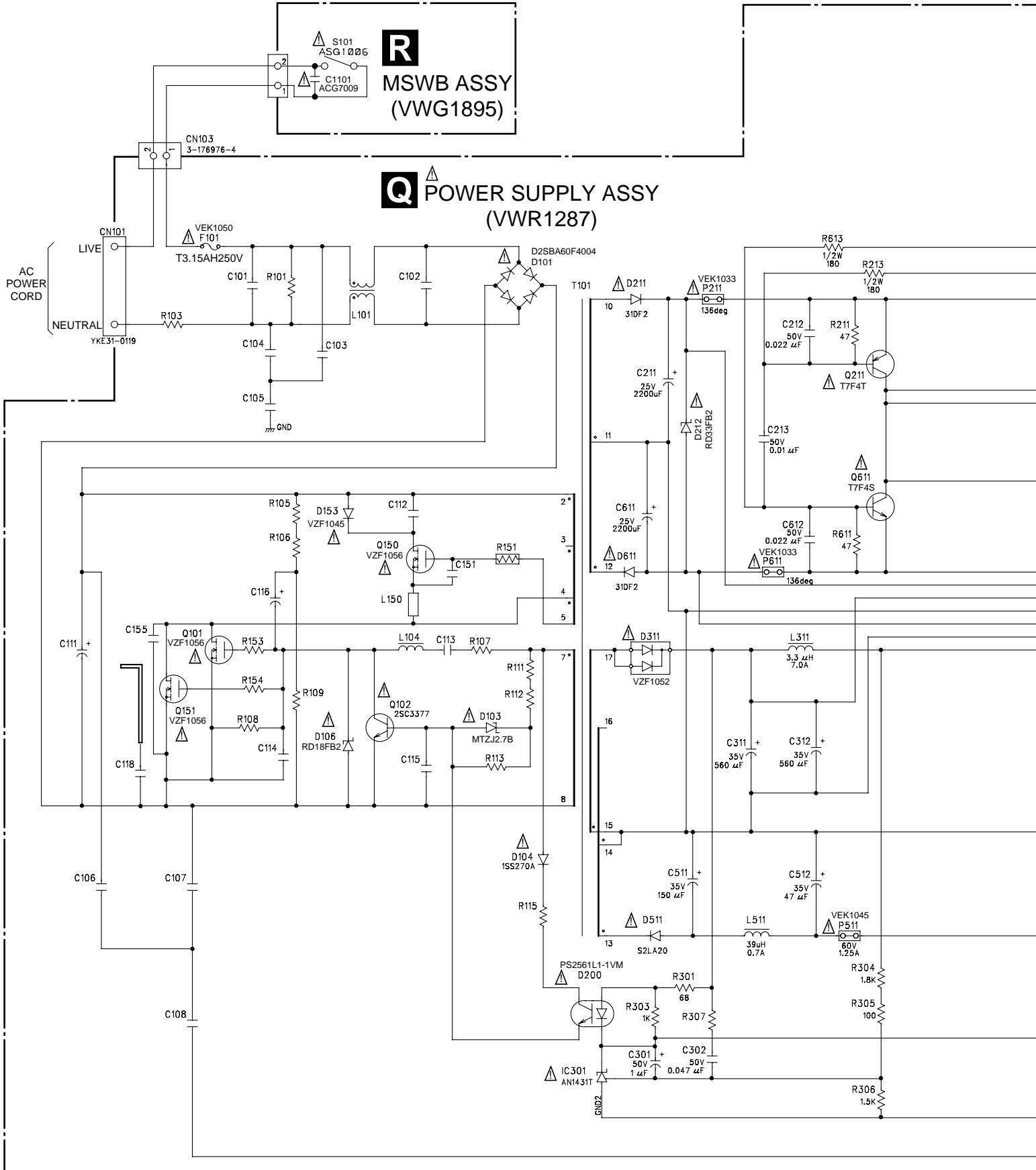

« NOTE OF SPARE PARTS IN POWER SUPPLY ASSY »

- In case of repairing, use the described parts only to prevent an accident.
- Please write the red ✓ mark on the board when the primary section of POWER SUPPLY Assy is repaired.
- Please take care to keep the space, not touching other parts when replacing the parts.

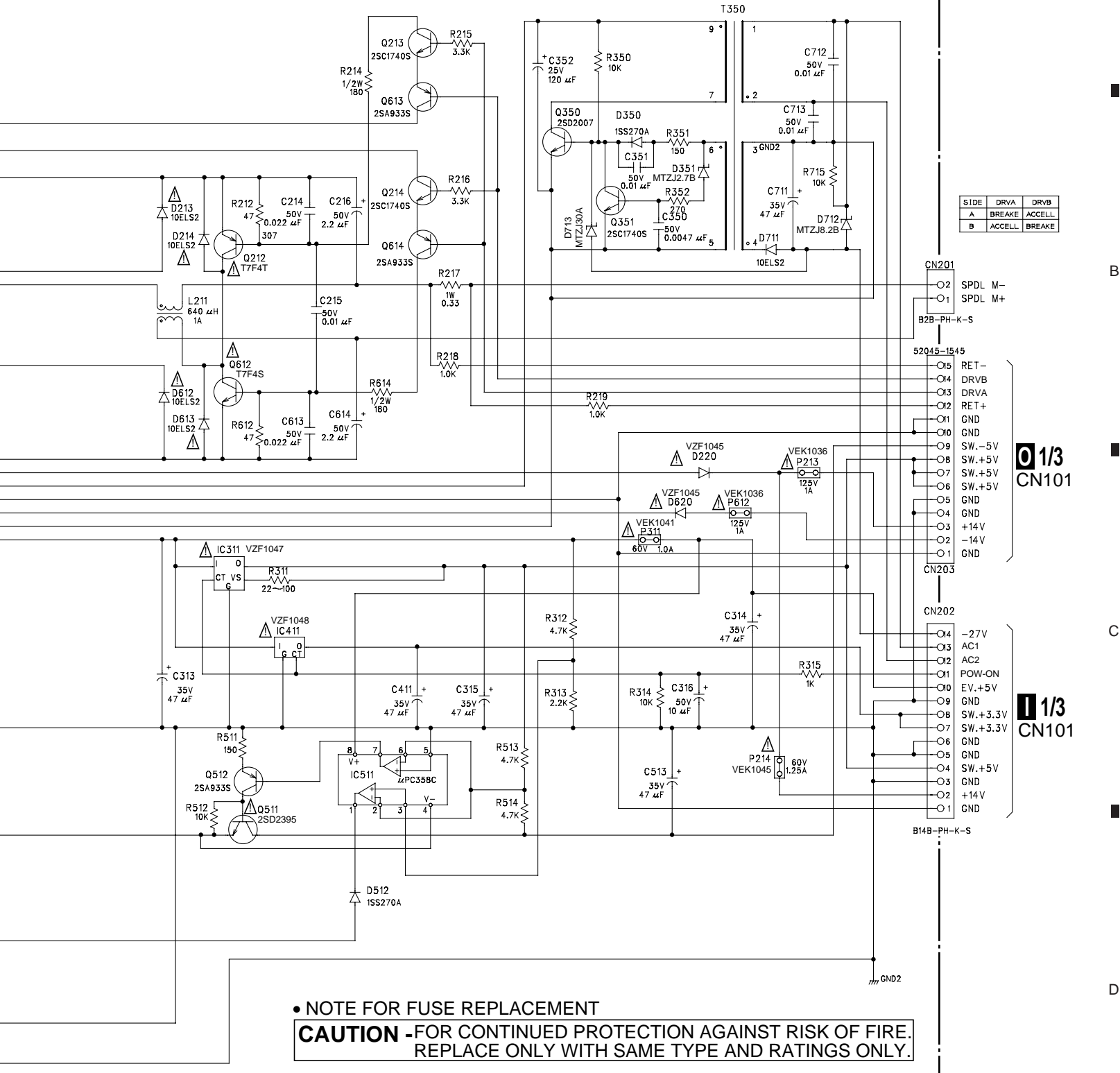

• NOTE FOR FUSE REPLACEMENT
CAUTION -FOR CONTINUED PROTECTION AGAINST RISK OF FIRE,
 REPLACE ONLY WITH SAME TYPE AND RATINGS ONLY.

1/3 CN101

1/3 CN101



4. PCB CONNECTION DIAGRAM

NOTE FOR PCB DIAGRAMS :

1. Part numbers in PCB diagrams match those in the schematic diagrams.
2. A comparison between the main parts of PCB and schematic diagrams is shown below.

Symbol In PCB Diagrams	Symbol In Schematic Diagrams	Part Name
		Transistor
		Transistor with resistor
		Field effect transistor
		Resistor array
		3-terminal regulator

3. The parts mounted on this PCB include all necessary parts for several destinations.
- For further information for respective destinations, be sure to check with the schematic diagram.
4. View point of PCB diagrams.

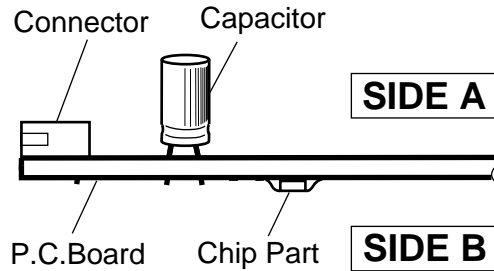

4.1 LMSB, PKSB AND FG ASSEMBLIES

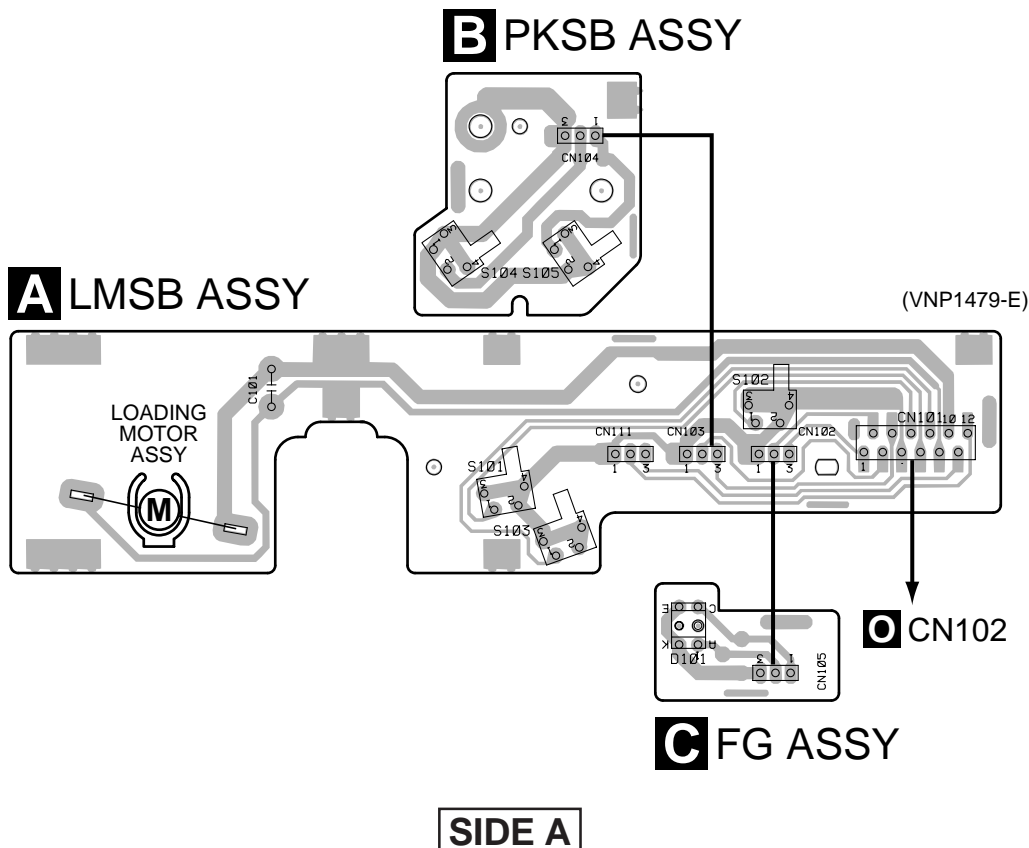

4.2 CNNB, TNMB, DCSB, LCSB AND BISB ASSEMBLIES

D CNNB ASSY

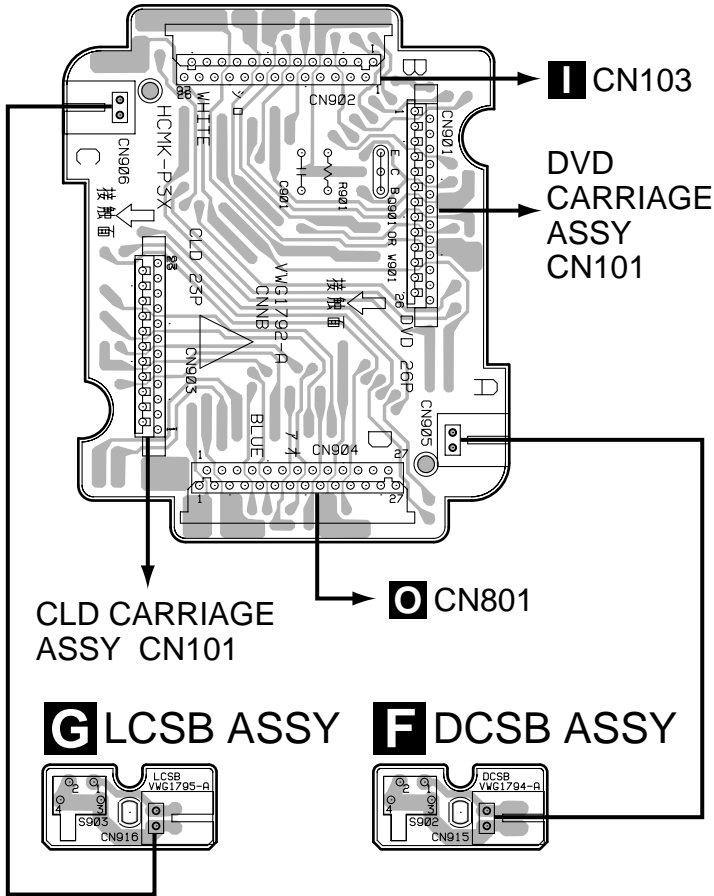

D CNNB ASSY

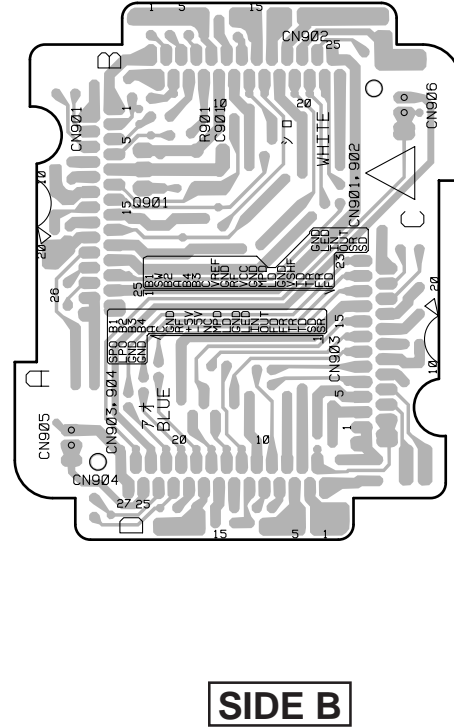

G LCSB ASSY

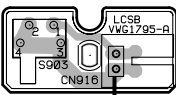

F DCSB ASSY

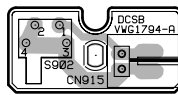

E TNMB ASSY

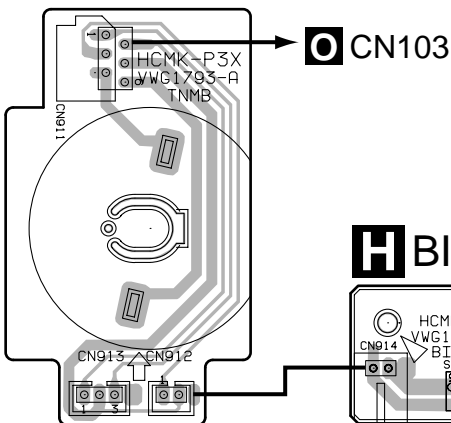

H BISB ASSY

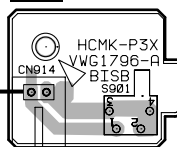

(VNP1599-B)

SIDE A

DVDM ASSY

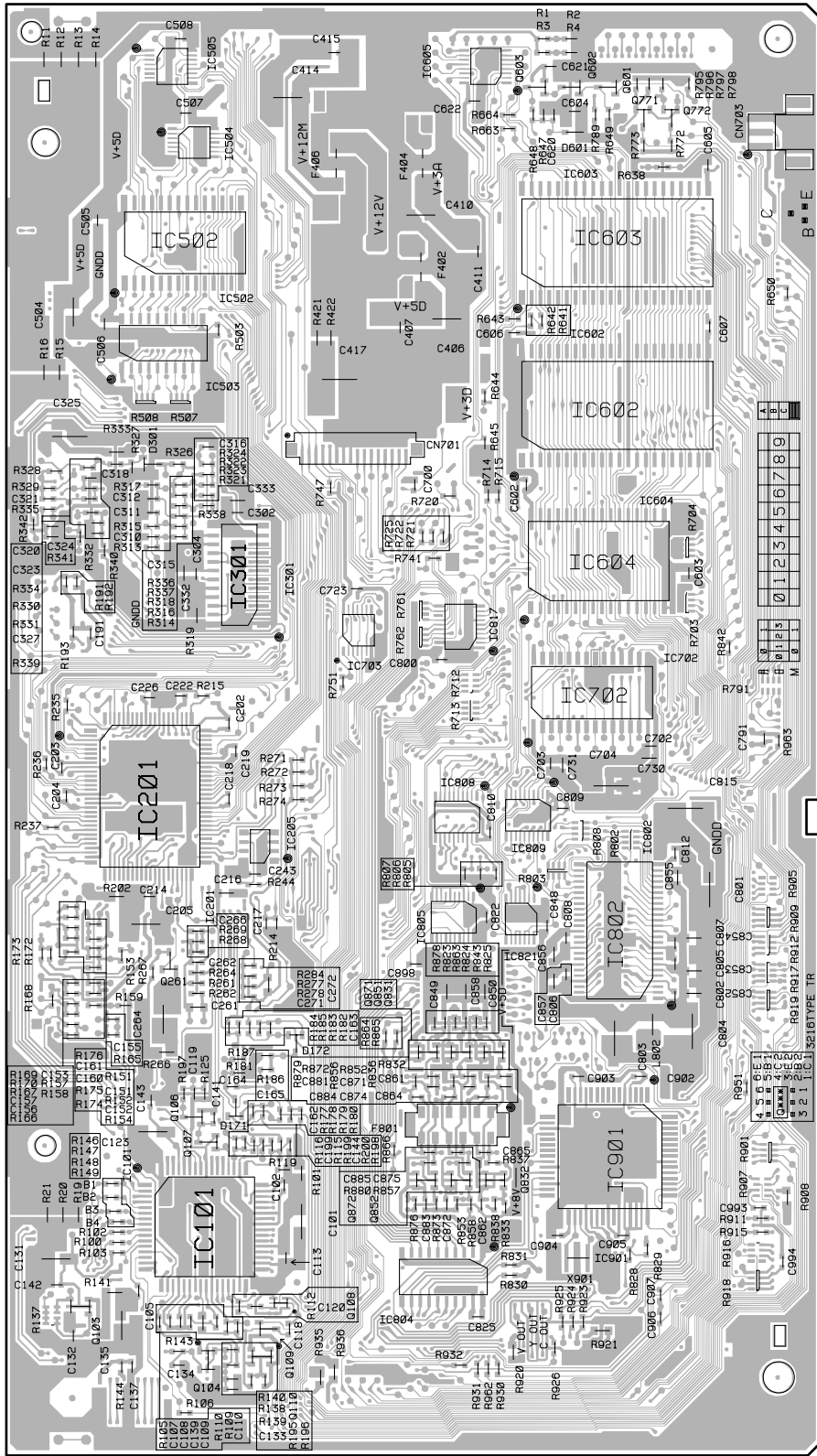

IC505	Q601	A
IC605	Q603	
IC504	Q771	
	Q772	
	Q773	
IC502	IC603	
IC503	IC602	
IC301	IC604	B
IC703	IC817	
IC702	IC808	
IC201	IC809	
IC205	IC805	
Q261	IC821	
	IC802	
Q871	Q851	C
Q831	Q832	
Q106	Q833	
Q107	IC901	
IC101	Q872	
	Q852	
	Q832	
Q103	IC804	
Q108	Q110	
Q110	Q104	D

(VNP1624-C)

SIDE B

4.4 KYCB ASSY

SIDE A

J KYCB ASSY

I CN903

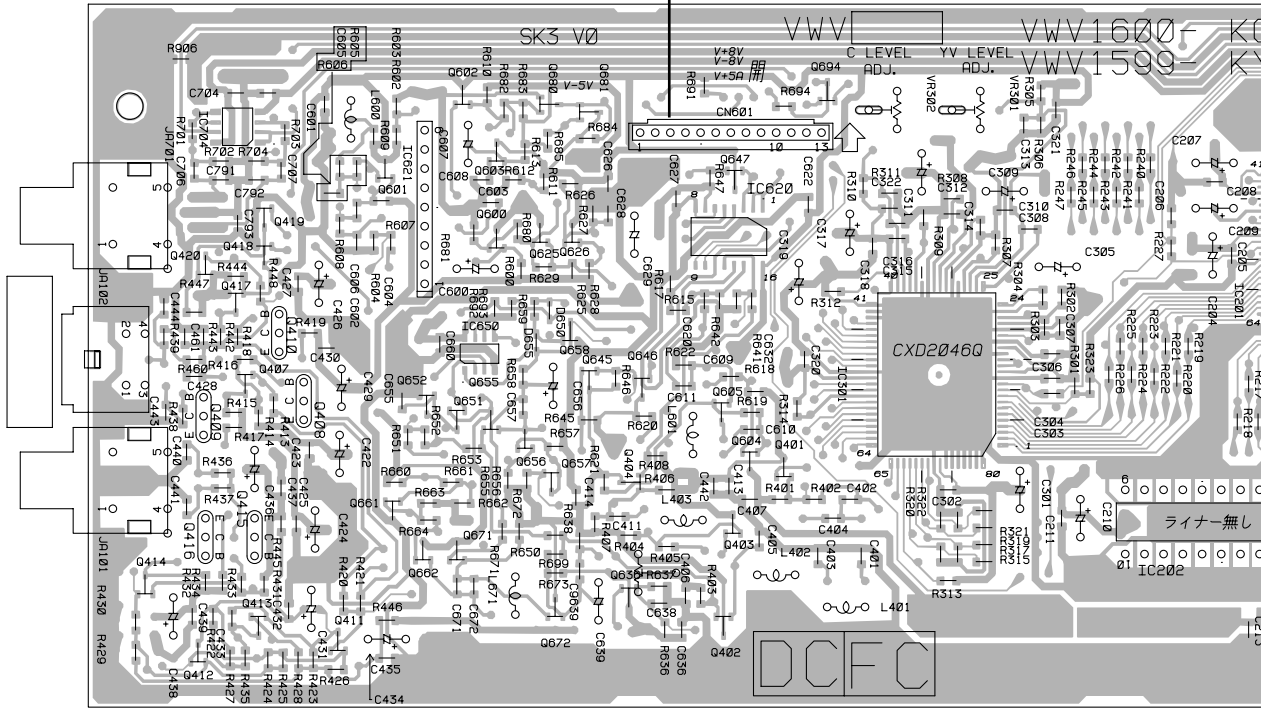

VR301

Q414	Q420	IC704	Q419	Q601	Q680	Q681	Q646	Q604	Q647	Q694	IC301	IC202
Q409	Q417	Q418	IC621	Q602	Q603	Q626	Q403	IC620				
Q416	Q407	Q410	Q652	Q600	Q625	Q658	Q402	Q401				
Q412	Q415	Q408	Q651	Q655	Q645	Q657	Q404					
	Q413	Q411	Q661	IC650	Q656	Q672	Q636					
				Q662	Q671							

SIDE B

J KYCB ASSY

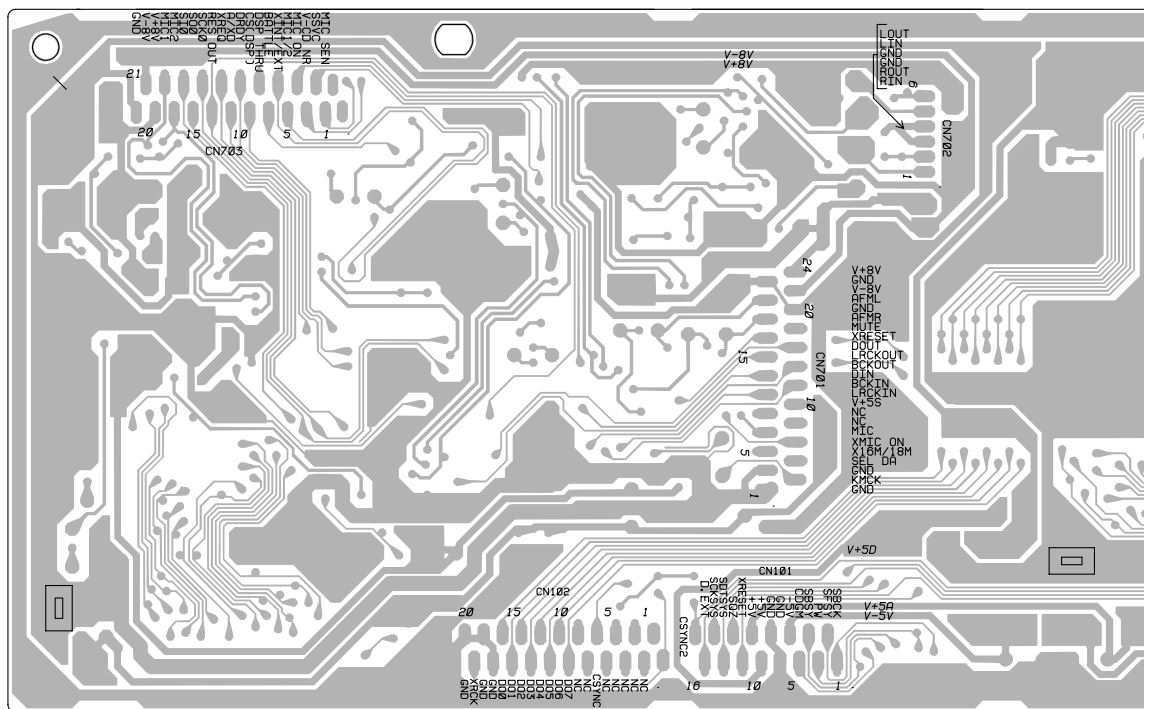

J

SIDE A

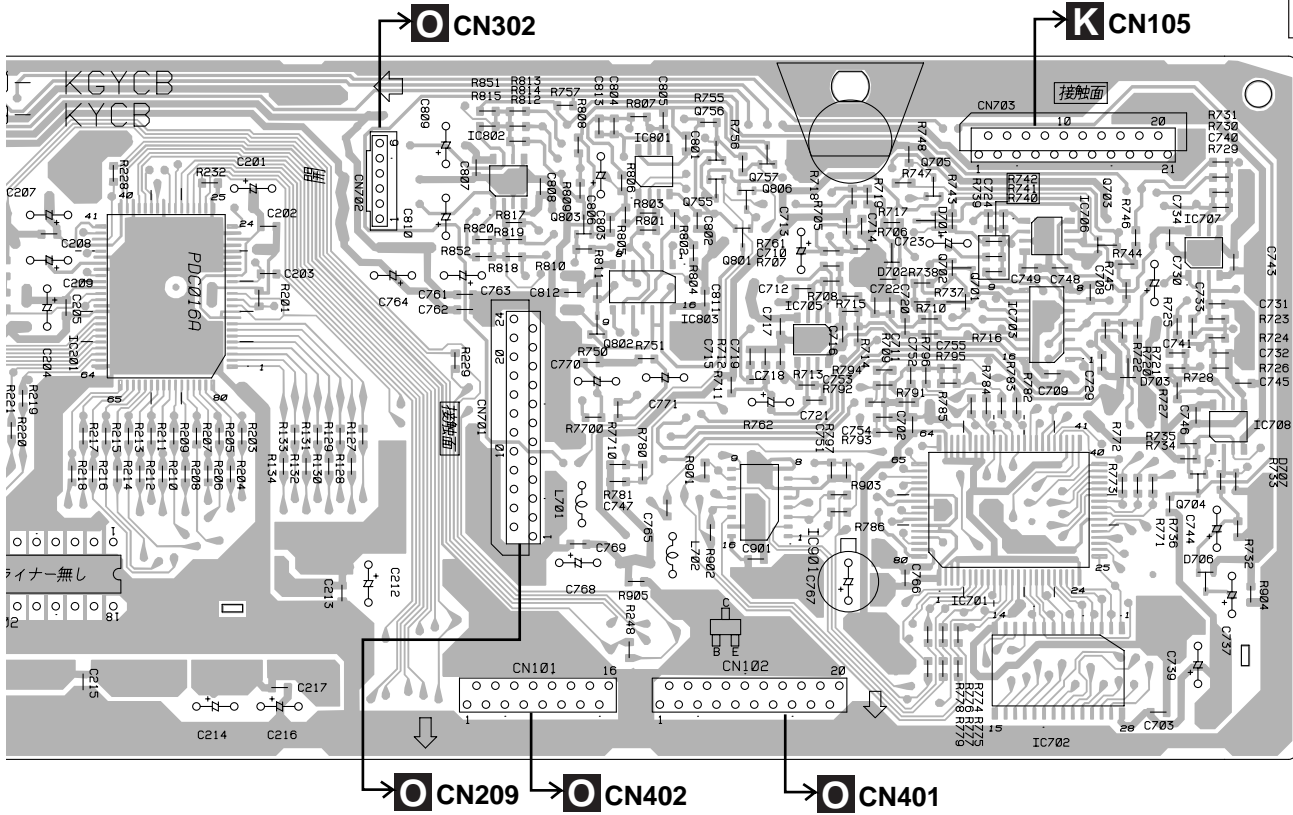

IC201	IC802	Q803	Q756	Q806	Q705	Q702	IC706	Q703	IC707
		Q802	Q755	Q801		Q701	IC703		Q704
		IC801	Q757	IC705		IC701	IC702		IC708
		IC803	IC705	IC901					

SIDE B

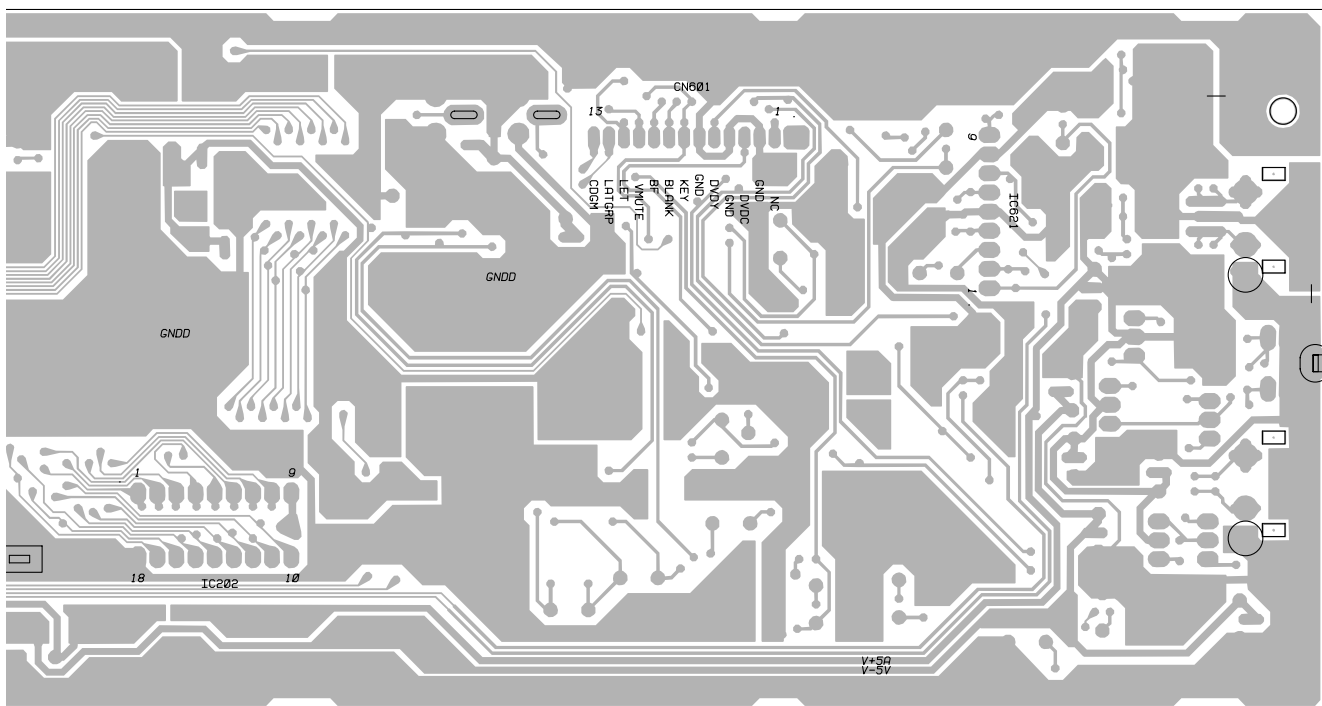

(VNP1641-C)



4.5 FLKY, KYLB, PWSB AND MICB ASSEMBLIES

SIDE A

L KYLB ASSY

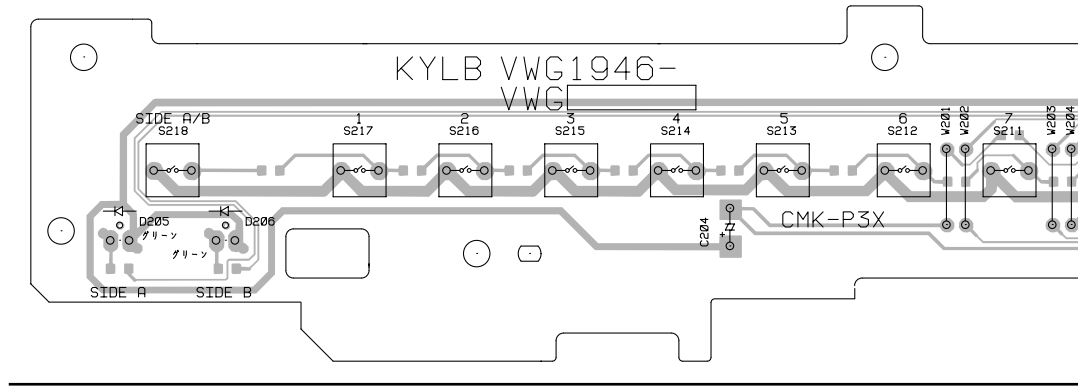

M PWSB ASSY

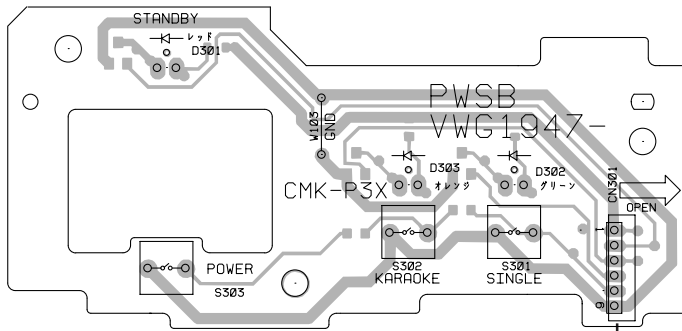

K FLKY ASSY

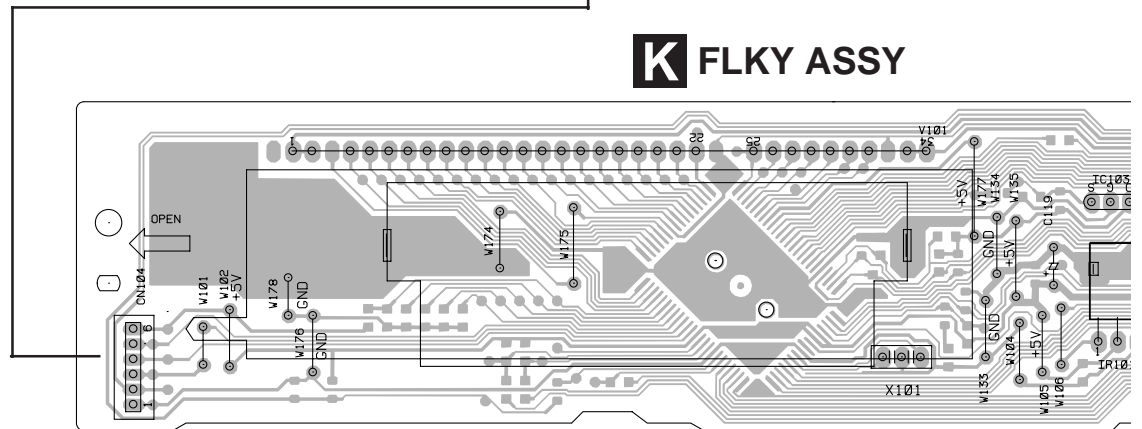

SIDE A

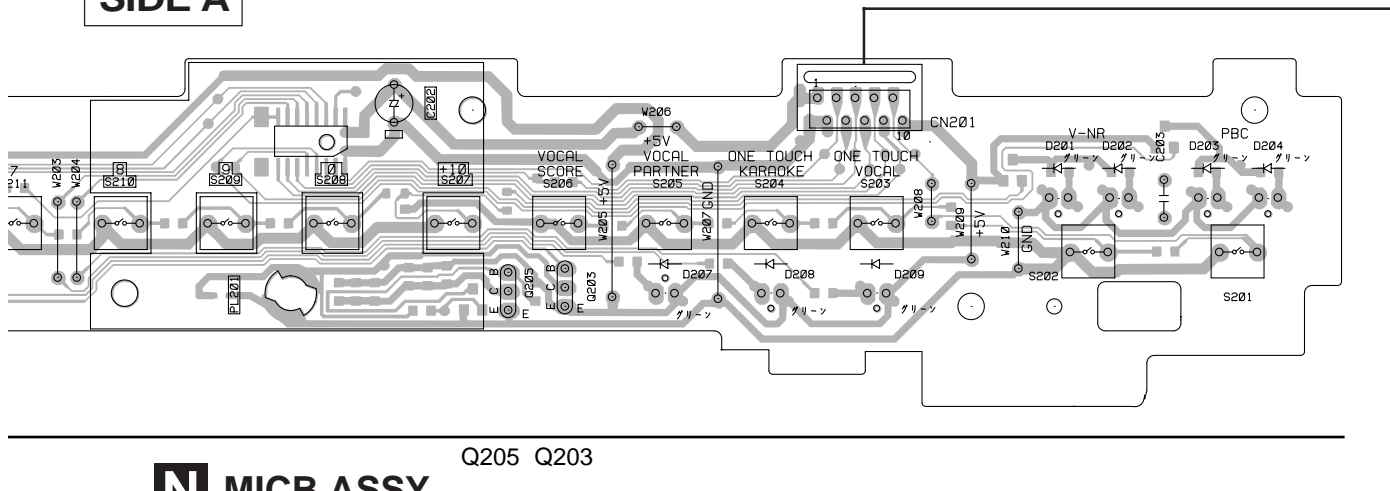

MICB ASSY

Q205 Q203

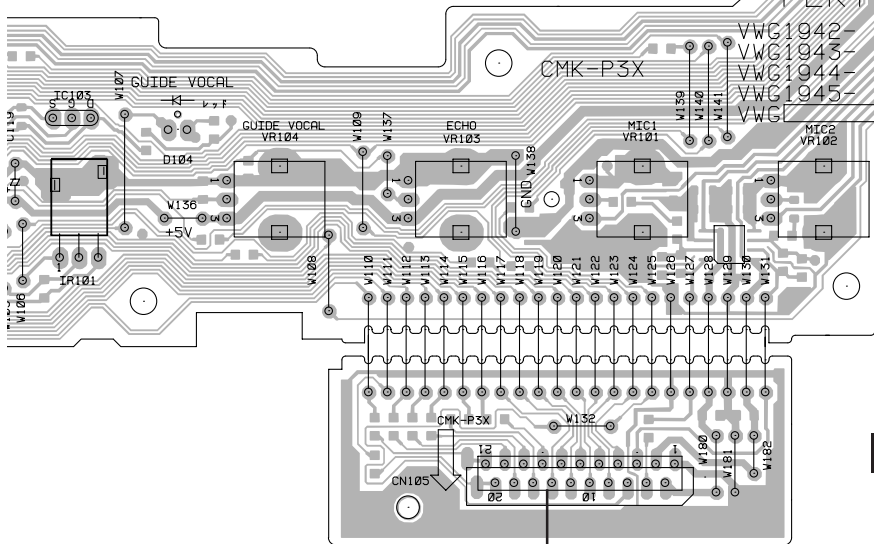
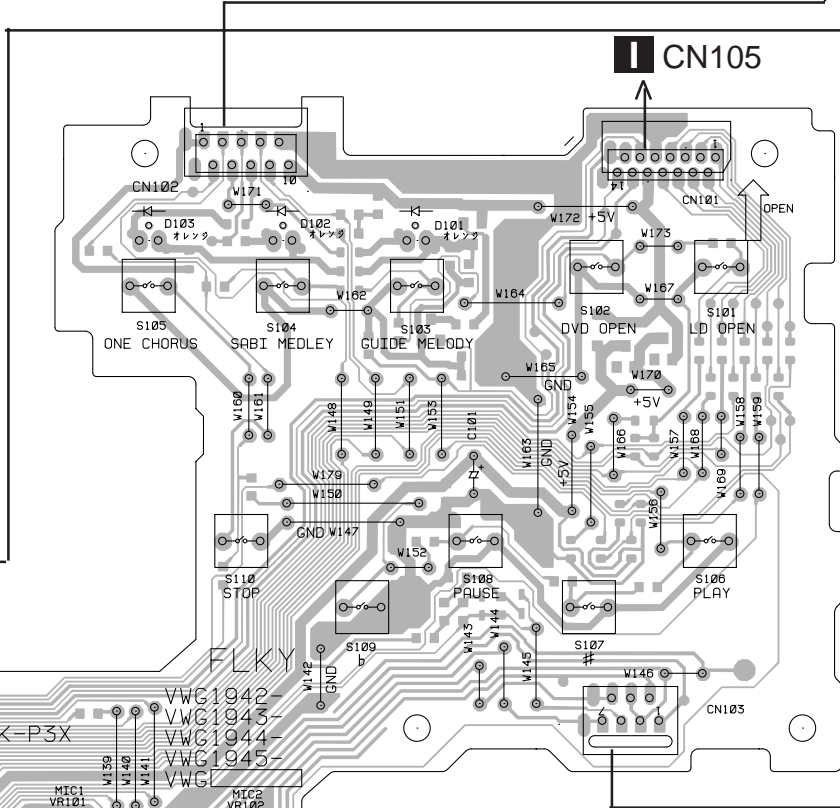
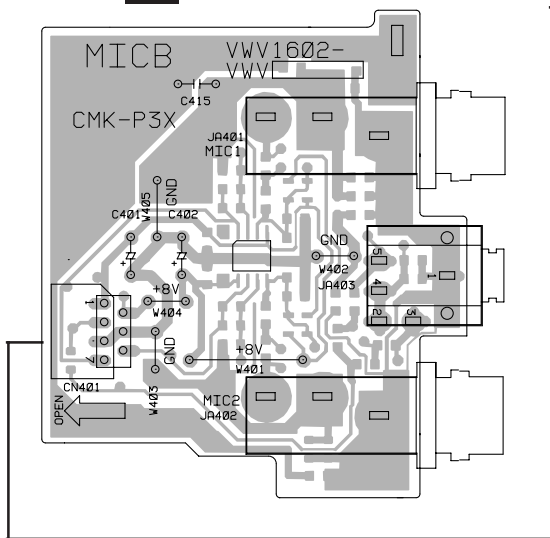

J CN703

IC103

(VNP1640-B)



SIDE B

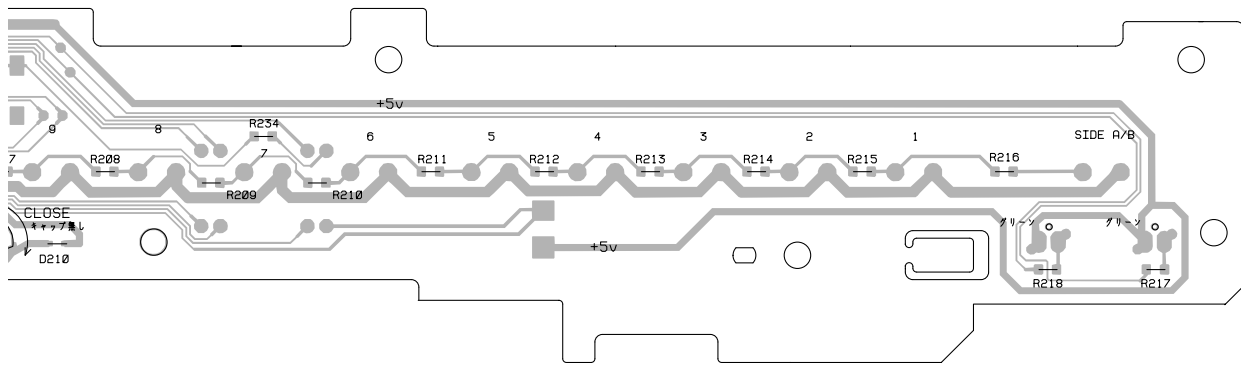

M PWSB ASSY

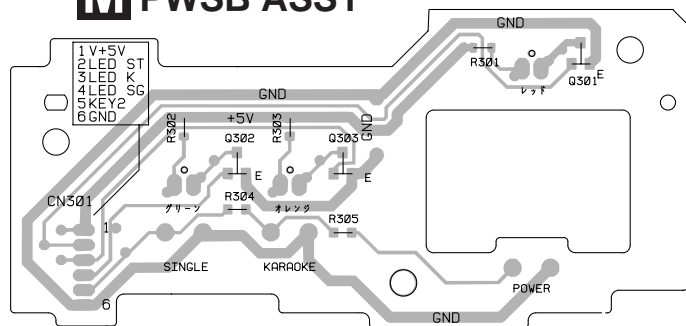

Q302 Q303 Q301

K FLKY ASSY

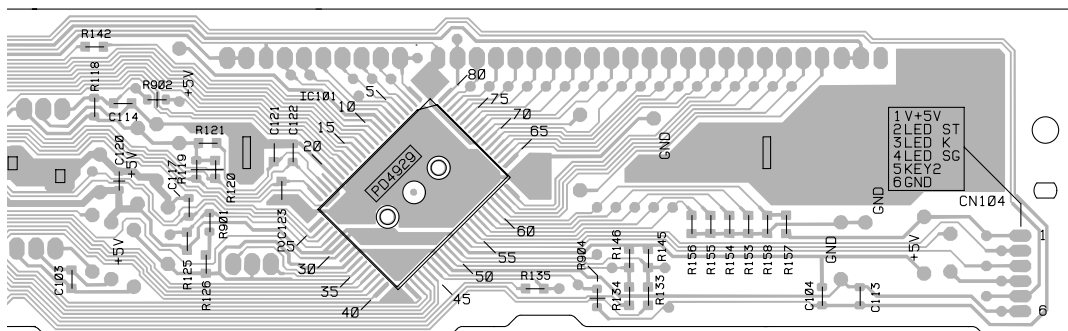

IC101

(VNP1640-B)

4.6 CLDM AND JCKB ASSEMBLIES

P JCKB ASSY

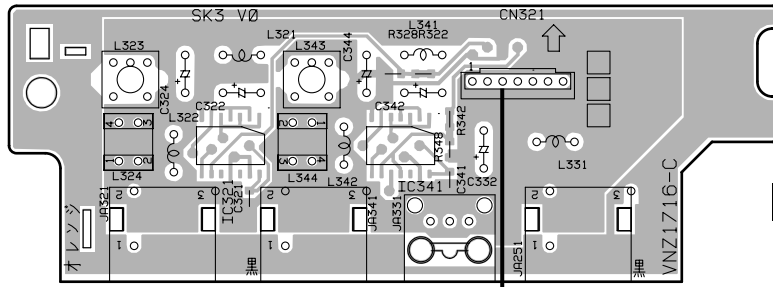

J CN701

I CN801

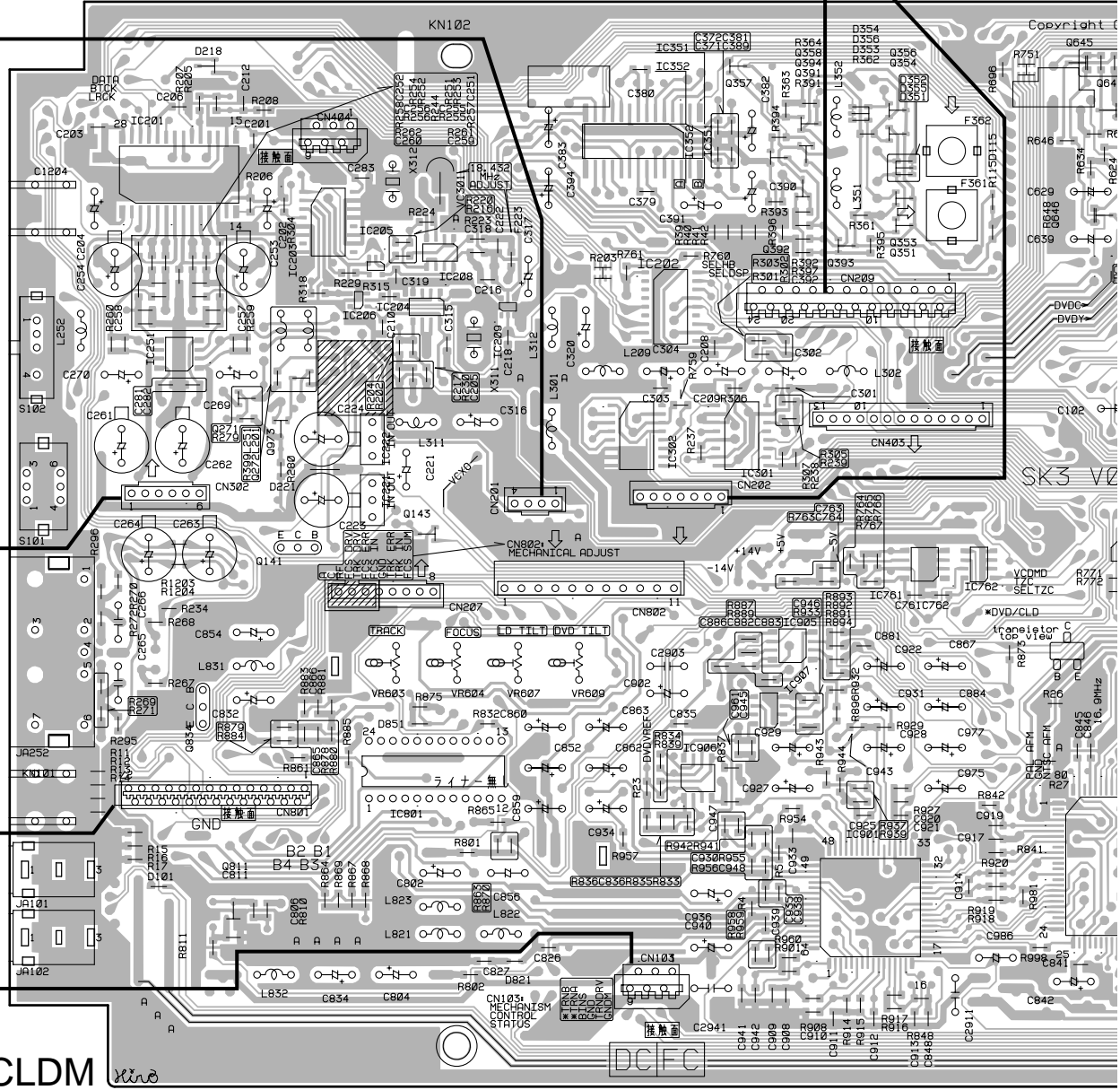

J CN702

D CN904

E CN911

O CLDM ASSY

VC301
VR603 VR604 VR607VR609

IC201	IC251	IC203—IC206	IC208	IC209	IC352	IC351	Q357	Q358	Q356	Q353	Q645—
Q834	Q271	Q973	Q272		IC202				Q354	Q351	
	Q811	Q141	IC222	Q143	IC302	IC301	Q391	Q394	IC761	IC762	
		IC221	IC801			IC905—IC907	IC901				IC9

SIDE A



A

B

C

D

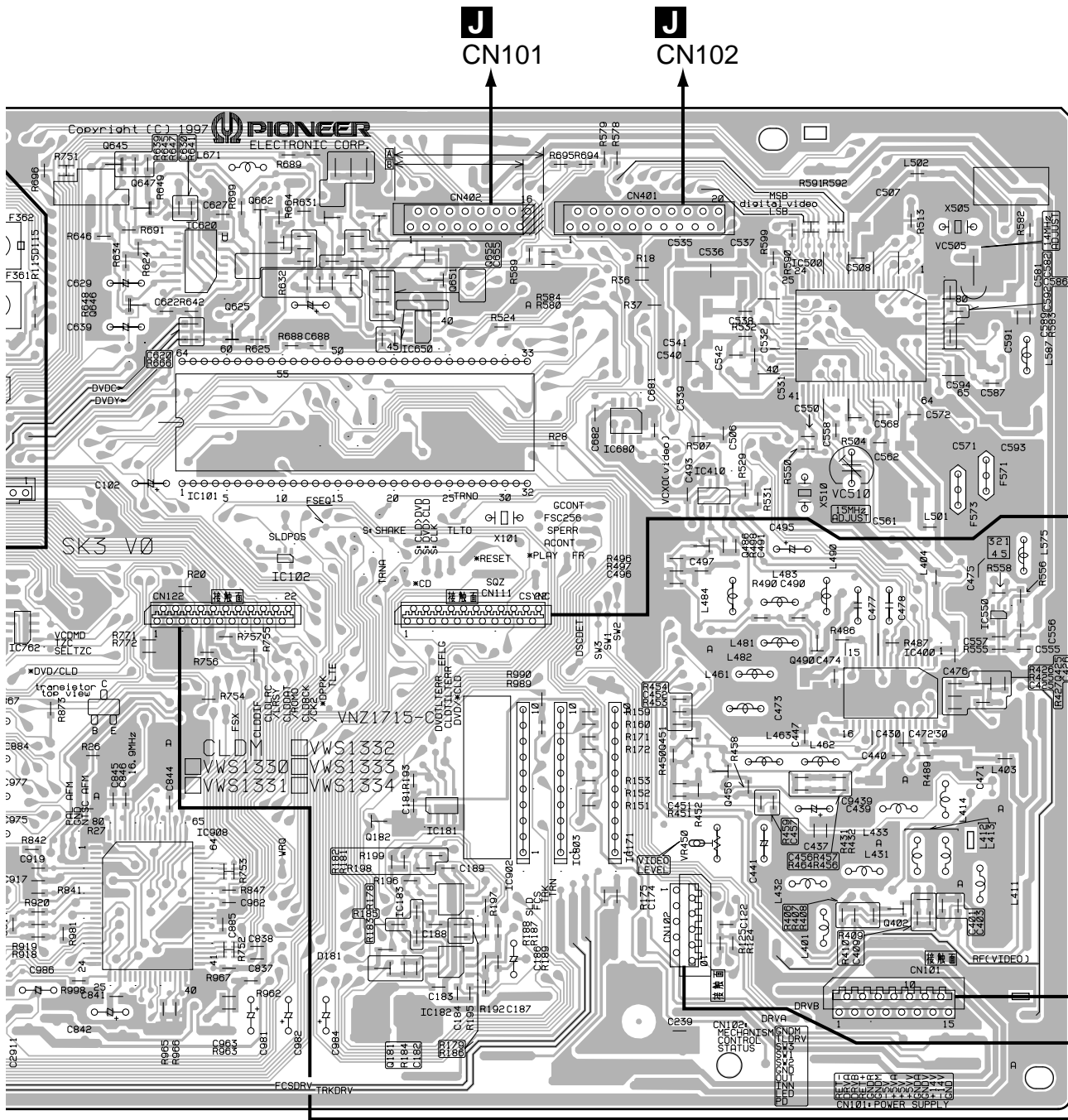

- Q645-Q647 Q662 Q652 Q651 IC680 IC410 IC500 IC550
- IC762 IC620 Q625 IC101 IC102 Q182 IC181-IC183 Q181 IC908 IC902 IC903 IC171 Q486 Q490 IC400 Q425

(VNP1630-C)

SIDE A



CLDM ASSY

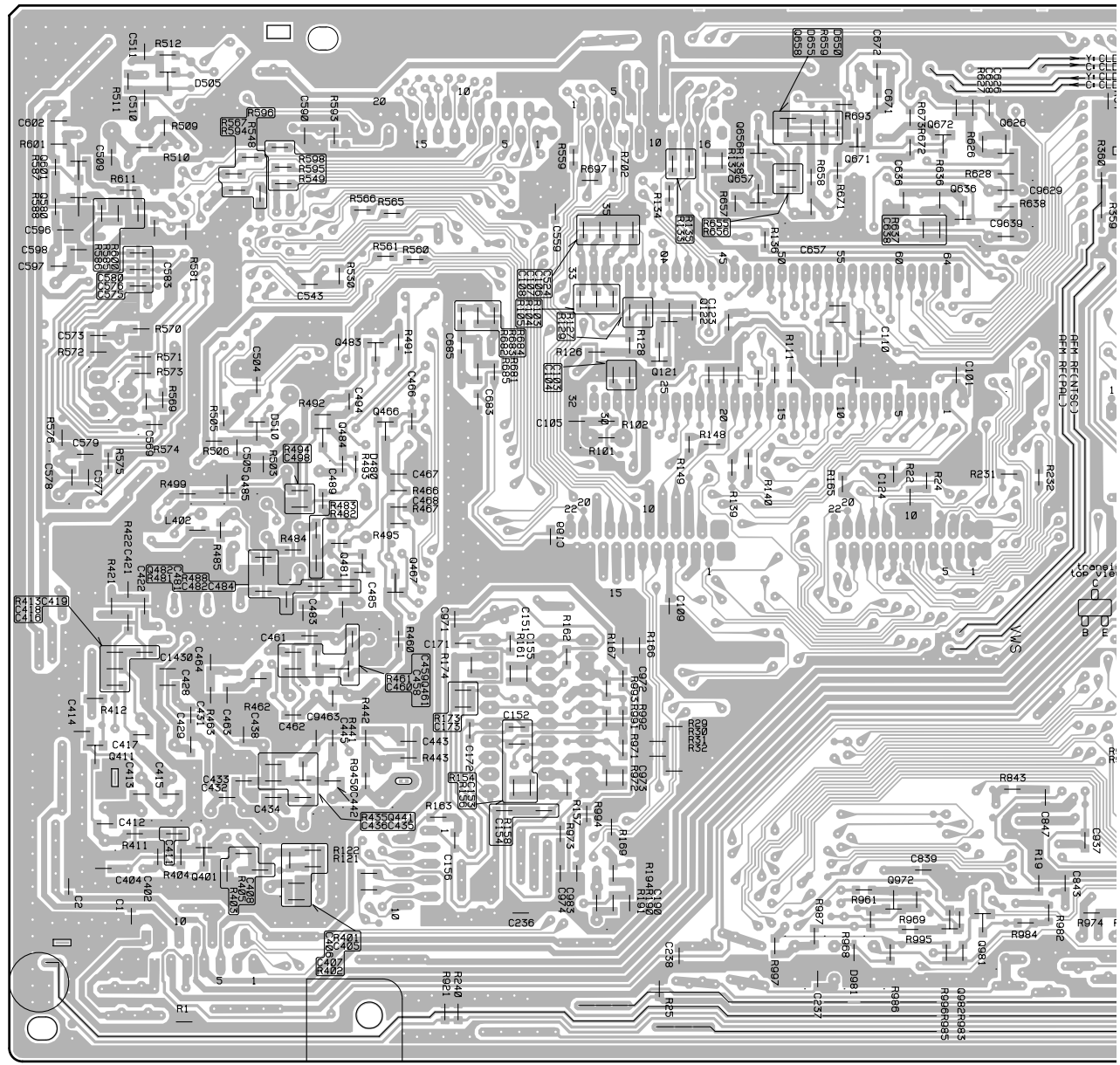

Q601 Q485 Q484 Q483 Q122 Q656-Q658 Q671 Q672 Q626
 Q580 Q482 Q481 Q466 Q121 Q636
 Q411 Q401 Q461 Q467 Q972 Q982 Q981
 Q441

SIDE B

P JCKB ASSY

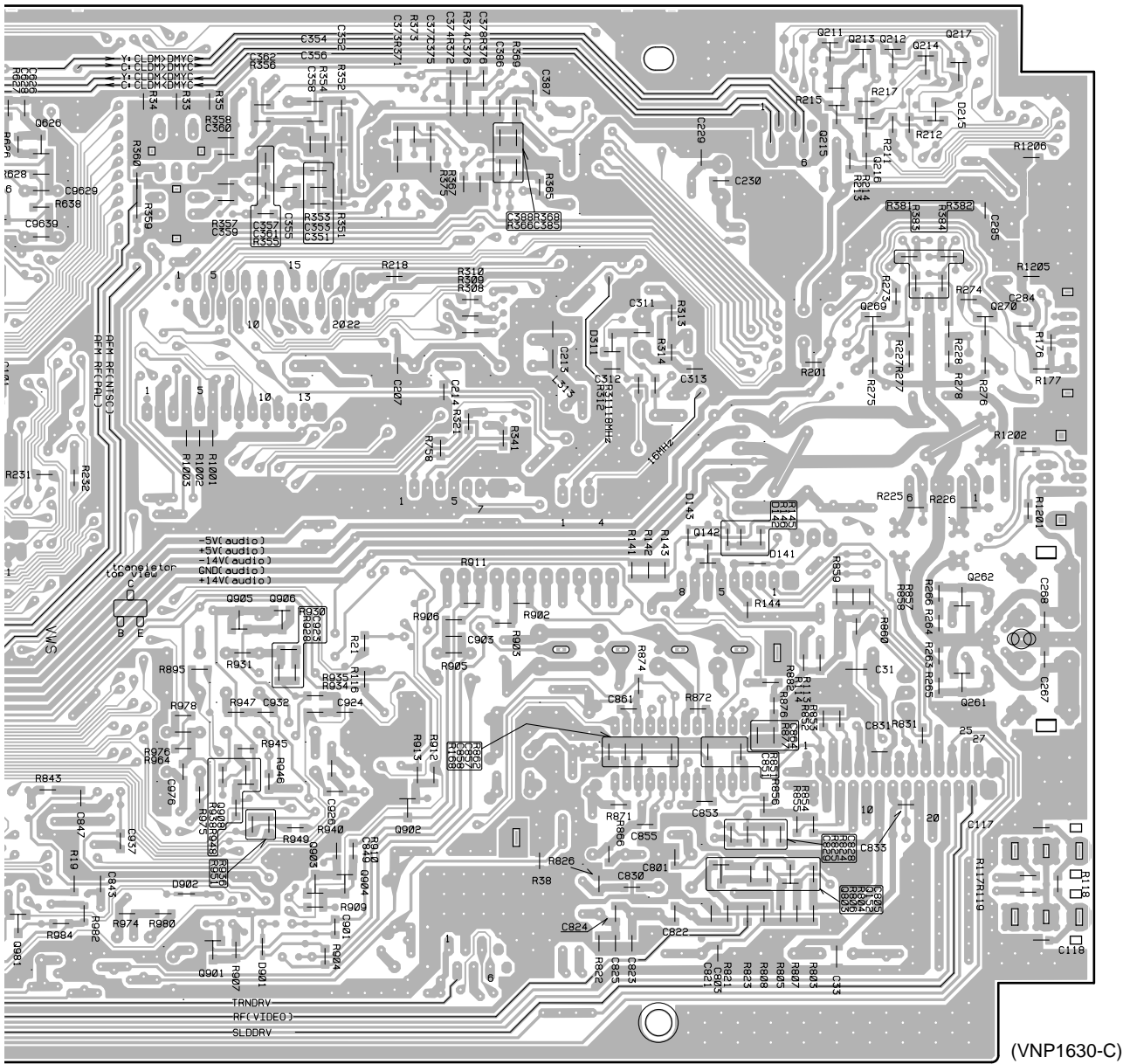
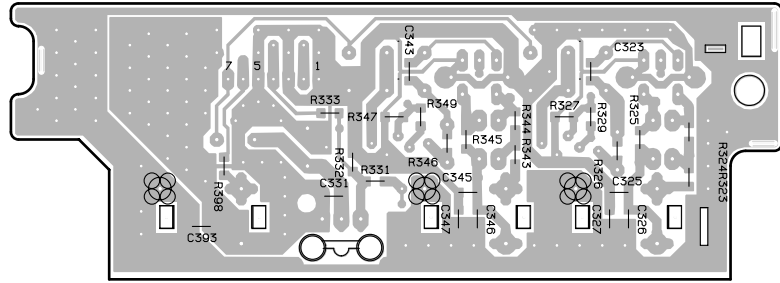

- Q626
636
Q981
- Q908
Q901 - Q906
- Q142
Q803
- Q211 - Q217
Q152 Q269
- Q270
Q262
Q261

SIDE B



4.7 POWER SUPPLY ASSY

Q POWER SUPPLY ASSY

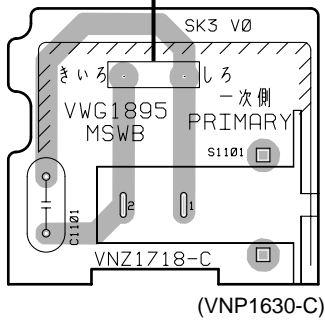
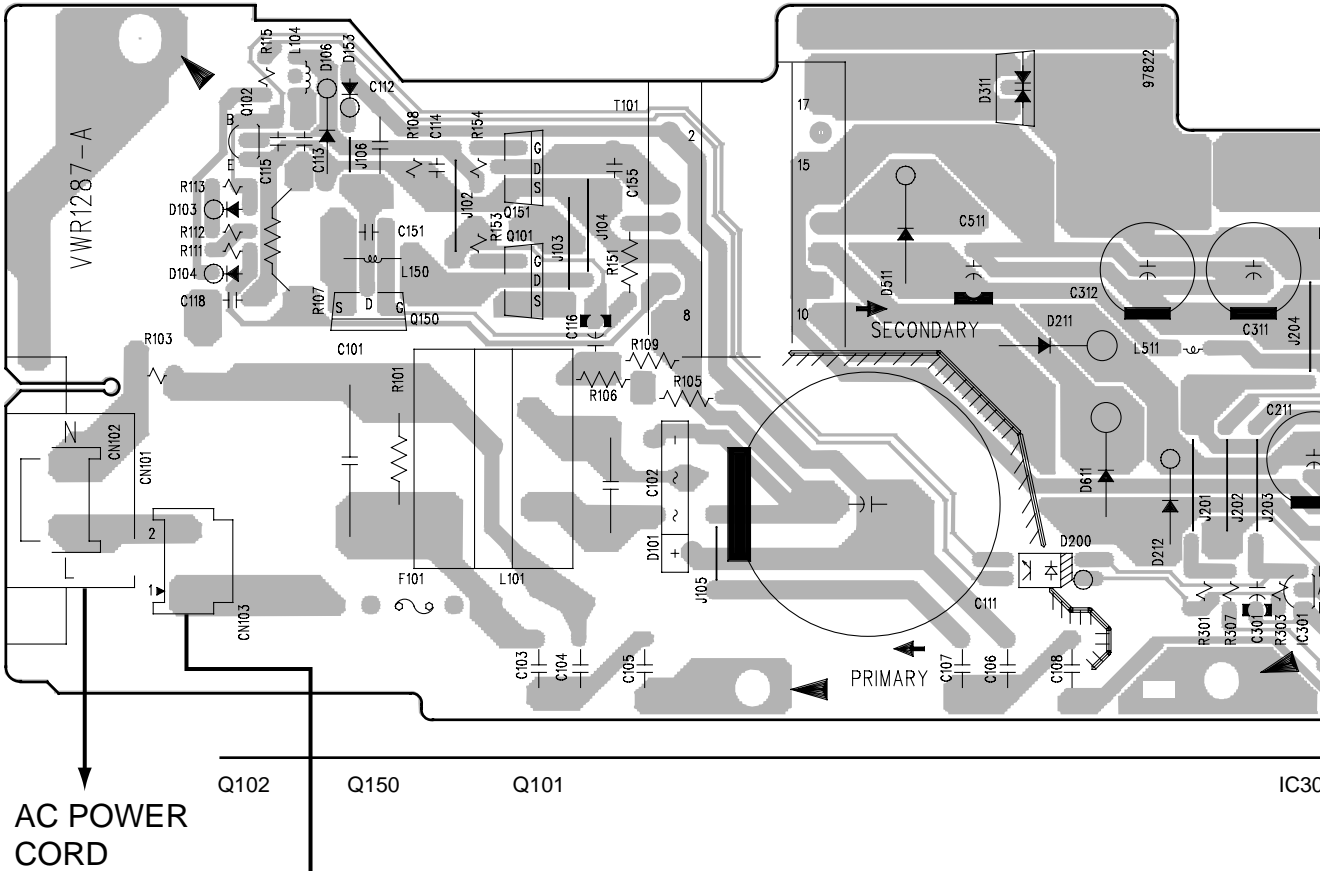

R MSWB ASSY

SIDE A

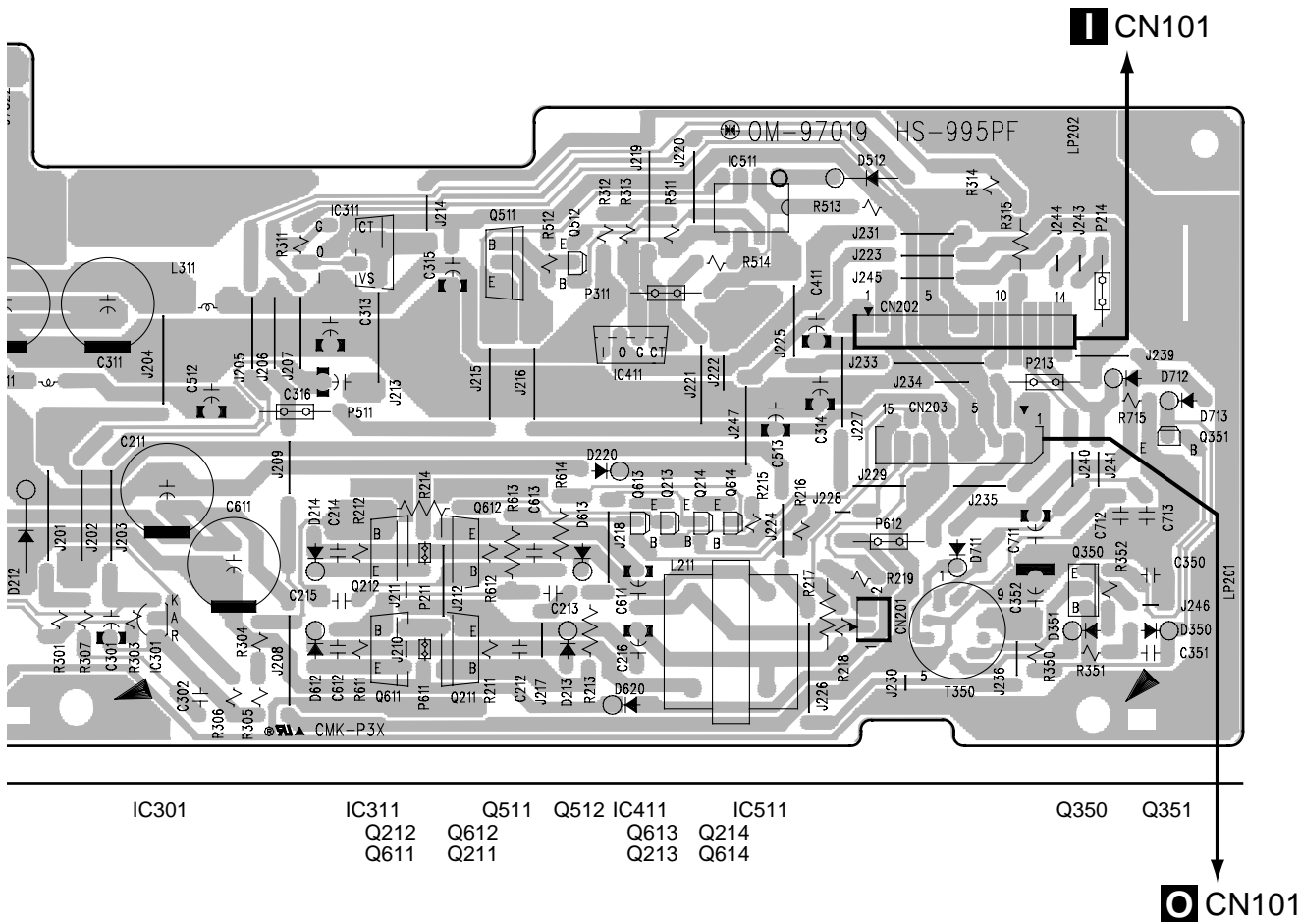

SIDE A

5. PCB PARTS LIST

NOTES: ● Parts marked by "NSP" are generally unavailable because they are not in our Master Spare Parts List.

● The Δ mark found on some component parts indicates the importance of the safety factor of the part. Therefore, when replacing, be sure to use parts of identical designation.

● When ordering resistors, first convert resistance values into code form as shown in the following examples.

Ex.1 When there are 2 effective digits (any digit apart from 0), such as 560 ohm and 47k ohm (tolerance is shown by J=5%, and K=10%).

560 → 56 x 10¹ → 561 RD1/4PU 561J

47k → 47 x 10³ → 473 RD1/4PU 473J

0.5 → R50 RN2H R50K

1 → 1R0 RS1P 1R0K

Ex.2 When there are 3 effective digits (such as in high precision metal film resistors).

5.62k → 562 x 10¹ → 5621 RN1/4PC 5621F

Mark	No.	Description	Part No.
------	-----	-------------	----------

LIST OF ASSEMBLIES

NSP	MACB ASSY	VWM1507
NSP	└LMSB ASSY	VWG1554
NSP	└PKSB ASSY	VWG1555
NSP	└FG ASSY	VWG1556
NSP	MECHB ASSY	VWM1721
NSP	└CNNB ASSY	VWG1792
NSP	└TNMB ASSY	VWG1793
NSP	└DCSB ASSY	VWG1794
NSP	└LCSB ASSY	VWG1795
NSP	└BISB ASSY	VWG1796
	DVDM ASSY	VWS1329
	KYCB ASSY	VWV1599
NSP	FRPB ASSY	VWM1829
	└FLKY ASSY	VWG1945
	└KYL B ASSY	VWG1946
NSP	└PWSB ASSY	VWG1947
	└MICB ASSY	VWV1602
NSP	CLDGM ASSY	VWM1808
	└CLDM ASSY	VWS1334
	└JCKB ASSY	VWV1580
	└MSWB ASSY	VWG1895
Δ	POWER SUPPLY ASSY	VWR1287

MACB ASSY

OTHERS

PC BOARD (MACB) VNP1479

A LMSB ASSY

SWITCHES

S101-S103 DSG1017

OTHERS

CN101 10P CONNECTOR 52044-1045

Mark	No.	Description	Part No.
------	-----	-------------	----------

B PKSB ASSY

SWITCHES

S104,S105 DSG1017

C FG ASSY

SEMICONDUCTOR

D101 GP1S24

MECHB ASSY

OTHERS

PC BOARD (MECHB) VNP1599

D CNNB ASSY

OTHERS

CN903	23P FFC CONNECTOR	52030-2310
CN901	26P FFC CONNECTOR	52030-2610
CN905,CN906	KR CONNECTOR	S2B-PH-K-S
CN902	26P FFC CONNECTOR	SLW26R-1C7
CN904	27P FFC CONNECTOR	SLW27R-1C7

E TNMB ASSY

OTHERS

CN911	6P FFC CONNECTOR	52044-0645
CN912	KR CONNECTOR	B2B-PH-K-S
CN913	KR CONNECTOR	B3B-PH-K-S

F DCSB ASSY

SWITCH

S902 DSG1017

Mark No. Description Part No.

OTHERS

CN915 KR CONNECTOR S2B-PH-K-S

G LCSB ASSY

SWITCH

S903 DSG1017

OTHERS

CN916 KR CONNECTOR S2B-PH-K-S

H BISB ASSY

SWITCH

S901 DSG1017

OTHERS

CN914 KR CONNECTOR S2B-PH-K-S

FRPB ASSY

OTHERS

PC BOARD (FRPB) VNP1640

K FLKY ASSY

SEMICONDUCTORS

IC102 BA4560F
IC101 PD4929B
IC103 S-806D
Q170 2SB1197K
Q171 PDTC124EK

D108 EP05Q04
D109,D110 RB411D
D101-D103 SLP6118C51H
D104 SLP9118C51H
D105,D106 UDZS5.6B

SWITCHES

S101-S110 RSG1030

CAPACITORS

C107,C109 CCSQSL271J50
C119 CEHAQ471M6R3
C108,C110 CKSQYB104K25
C114,C117 CKSQYF102Z50
C102,C103,C105,C106 CKSQYF103Z50

C115,C116,C120-C125 CKSQYF103Z50
C111,C112,C170 CKSQYF225Z16

RESISTORS

R119-R121 RN1/10SE1001D
VR101-VR104 10kΩ(B) VCS1041
Other Resistors RS1/10S□□□J

Mark No. Description Part No.

OTHERS

CN104 FJ CONNECTOR 6P 06R-FJ
CN105 21P FFC CONNECTOR 52045-2145
CN103 7P FFC CONNECTOR 52492-0720
CN102 10P FFC CONNECTOR 52492-1020
REMOTE RECEIVER UNIT GP1U28X

V101 FL TUBE VAW1046
SPACER VEC1599

CN101 14P CONNECTOR VKN1274
HOLDER VNF1087

X101 CERAMIC RESONATOR(5MHz) VSS1104

L KYLB ASSY

SEMICONDUCTORS

IC201 BU2090F
Q204 2SC2412K
Q203 DTB113ES
Q205 DTD113ES
Q201,Q202 PDTA124EK

D210 MA111
D201-D209 SLP7118C51H

SWITCHES

S201-S218 RSG1030

CAPACITORS

C204 CEAL101M6R3
C202 CEJA470M6R3
C201 CKSQYF103Z50

RESISTORS

All Resistors RS1/10S□□□J

OTHERS

CN201 10P FFC CONNECTOR 52492-1020
PL201 LAMP VEL1022

M PWSB ASSY

SEMICONDUCTORS

Q301-Q303 PDTC124EK
D303 SLP6118C51H
D302 SLP7118C51H
D301 SLP9118C51H

SWITCHES

S301-S303 RSG1030

RESISTORS

All Resistors RS1/10S□□□J

OTHER

CN301 FJ CONNECTOR 6P 06PL-FJ

N MICB ASSY

SEMICONDUCTORS

IC401 NJM2068M
D401-D404 UDZS10B

DVL-K88

Mark	No.	Description	Part No.
FILTER			
	F405		VTF1096

CAPACITORS

C401,C402	CEAT101M10
C405,C408	CKSQYB122K50
C406,C409	CKSQYB152K50
C403,C404	CKSQYF103Z50
C412,C413	CKSQYF104Z50

RESISTORS

All Resistors	RS1/10S□□□J
---------------	-------------

OTHERS

CN401	7P FFC CONNECTOR	52044-0745
JA403	JACK	RKN1006
JA401,JA402	JACK	VKN1147
	SNAP PLATE	VNE1102
	JACK HOLDER	VNE2118

Q POWER SUPPLY ASSY

SEMICONDUCTORS

△	IC301		AN1431T
△	IC311	(SI-3050CA)	VZF1047
△	IC411	(PQ3RD13)	VZF1048
	IC511		UPC358C
△	Q101,Q150,Q151	FET(2SK2333)	VZF1056
△	Q102		2SC3377
△	Q211,Q212		T7F4T
	Q213,Q214,Q351		2SC1740S
	Q512,Q613,Q614		2SA933S
△	Q611,Q612		T7F4S
	Q350		2SD2007
△	Q511		2SD2395
△	D101		D2SB60F4004
△	D103		MTZJ2.7B
	D351		MTZJ2.7B
△	D104		1SS270A
	D350,D512		1SS270A
△	D106		RD18FB2
△	D153,D220,D620	DIODE(D1N60)	VZF1045
△	D200		PS2561L1-1VM
△	D211,D611		31DF2
△	D212		RD33FB2
△	D213,D214,D612,D613		10ELS2
	D711		10ELS2
△	D311	DIODE(F10P04Q)	VZF1052
△	D511		S2LA20
	D713		MTZJ30A
	D712		MTZJ8.2B

OTHERS

△	F101	FUSE(3.15A/250V)	VEK1050
△	P211,P611	FUSE(136°C)	VEK1033
△	P213,P612	FUSE(1A/125V)	VEK1036

Mark	No.	Description	Part No.
△	P214,P511	FUSE(1.25A/60V)	VEK1045
△	P311	FUSE(1A/60V)	VEK1041

I DVDM ASSY

SEMICONDUCTORS

IC171	BA10393F
IC151	BA6797FP
IC813	CY2081SL-611
IC702	HM514800CJ-7
IC101	LA9700M
IC201	LC78650E-P
IC802	MB811171622A-100FN
IC801	MB86371
IC815,IC816	MC14577CF
IC271,IC302	NJM2100M
IC203	NJM2107F
IC601	PD3381A
IC701	PD4833A
IC501	PD4889A
IC602	PDK026B
IC502	SRM2B256SLMX70
IC401	TA78M08F
IC202,IC204,IC206	TC4W53F
IC604	TC551001BFL-85
IC503	TC74HC573AF
IC804	TC74HCT541AF
IC303	TC74HCU04AF
IC807,IC808	TC74LCX245FT
IC821	TC74VHC00FT
IC814,IC820	TC74VHC02FT
IC505,IC605	TC74VHC139FT
IC703	TC74VHC14FT
IC504	TC74VHC20FT
IC805,IC806,IC809	TC74VHC541FT
IC506	TC74VHCT245AFT
IC817	TC74VHCT541AFT
IC811,IC818,IC819	TC7SHU04F
IC810	TC7WU04F
IC301	TLC5540INS
IC603	VKH1012
IC6003	VYW1538
Q401	2SB1260
Q108	HN1K03FU
Q455,Q831,Q832,Q851,Q852	IMT1A
Q871,Q872	IMT1A
Q103,Q402,Q403,Q873	IMX1
Q102,Q104,Q291,Q301	IMZ1A
Q106,Q603	PDTA114EK
Q107,Q109,Q602	PDTC114EK
Q601,Q771,Q772	PDTC114TK
D301	KV1410
D171,D172	MA152WK
D601	RB501V-40

COILS AND FILTERS

F771,F778,F779	CHIP BEADS	DTF1067
F896	FERRITE CORE	VTF1077

DVL-K88

Mark	No.	Description	Part No.
	CN901,CN902	22P FFC CONNECTOR	VKN1426
	CN103	26P FFC CONNECTOR	VKN1430
	KN1-KN3	EARTH METAL FITTING LABEL	VNF1109 VRW1634
	X602	CERAMIC RESONATOR(20MHz)	VSS1114
	X501	CERAMIC RESONATOR(10MHz)	VSS1115

CLDGM ASSY

OTHERS

PC BOARD (CLDGM)	VNP1630
------------------	---------

CLDM ASSY

CEMICONDUCTORS

IC761	BA10393F
IC251,IC680,IC905,IC906	BA4560F
IC352	CA0002AM
IC171,IC803	LA6510
IC400	LA7134M
IC801	LA9425
IC901	LA9430M
IC908	LC78625E
IC182,IC183	MM6558XF
△ IC221	NJM78L08A
△ IC222	NJM79L08A
IC101	PD0260A2
IC201	PD2029AM(L)
IC500	PD6159B
IC902	TA8410AK
IC181,IC762,IC907	TC4W53F
IC203	TC74HC157AF
IC205,IC206	TC7S02F
IC102	TC7S32F
IC209,IC550	TC7SU04F
IC204,IC208	TC7WU04F
Q121,Q182,Q482,Q580	2PB709A
Q269,Q270,Q391-Q393,Q401	2PD601A
Q441,Q481,Q803,Q811	2PD601A
Q903-Q906	2PD601A
Q834	2SA854S
Q152	2SC3082K
Q261,Q262	2SD2114K
Q211-Q214,Q217,Q394,Q981	PDTA124EK
Q122,Q181,Q215,Q216,Q901	PDTC124EK
Q908	PDTC124EK
D215	DAN202K
D221	EC10QS04
D311,D505	KV1851
D101,D181,D902,D981	MA111
D218	MA152WK
D115	UDZS5.1B

COILS AND FILTERS

F590	CHIP BEADS	DTF1067
L9231,L9232	CHIP INPEDER	DTL1028
L413		LAU100J
L401		LAU101J

Mark	No.	Description	Part No.
	L352,L821-L823		LAU181J
	L201,L251,L252,L311,L312		LAU220J
	L351,L412,L461,L482		LAU220J
	L831,L832		LAU220J
	L411,L587		LAU270J
	L431,L432,L575		LAU430J
	L462		LAU560J
	L414		LAU8R2J
	L463		LFA561J
	F573	14.3MHz FILTER	VTF1099
	L403,L404	(22μH)	VTL1058
	L223,L230	CHIP BEADS	VTL1098

CAPACITORS

C229,C417,C418,C421,C434	CCSQCH100D50
C543,C577	CCSQCH100D50
C353,C821,C837-C839,C843	CCSQCH101J50
C864,C865	CCSQCH101J50
C921,C943	CCSQCH102J50
C432,C436,C483	CCSQCH120J50
C412	CCSQCH121J50
C408,C414,C484,C569	CCSQCH150J50
C355,C823,C901	CCSQCH151J50
C313,C352	CCSQCH180J50
C205,C212,C509,C824,C973	CCSQCH220J50
C413,C555	CCSQCH221J50
C550	CCSQCH240J50
C230,C354,C411,C416,C431	CCSQCH270J50
C830	CCSQCH270J50
C104,C105,C356,C433,C451	CCSQCH330J50
C579,C596	CCSQCH330J50
C351,C407,C485	CCSQCH390J50
C9244	CCSQCH391J50
C217,C222,C257-C260,C405	CCSQCH470J50
C461,C590	CCSQCH470J50
C925	CCSQCH471J50
C941	CCSQCH561J50
C597	CCSQCH5R0C50
C358,C598,C806	CCSQCH680J50
C920	CCSQCH681J50
C435,C822,C829	CCSQCH7R0D50
C255,C256,C357,C825	CCSQCH820J50
C459,C462	CCSQCH910J50
C123	CCSLSL102J50
C261-C264	CEAL470M10
C986	CEANP3R3M50
C187,C441,C856	CEANP470M6R3
C221,C394,C975	CEAT100M50
C391,C437,C832,C834,C884	CEAT101M10
C269,C270,C867,C929	CEAT1R0M50
C927,C928,C931,C981,C982	CEAT220M50
C102,C202,C223,C224	CEAT470M16
C316,C317,C382,C390,C802	CEAT470M16
C804,C842,C852,C854	CEAT470M16
C859,C860	CEAT470M16
C253,C254	CEAT471M6R3
C984	CEAT4R7M50
C383,C922	CEATR47M50
C936,C940	CEJA101M6R3

DVL-K88

Mark	No.	Description	Part No.
------	-----	-------------	----------

J KYCB ASSY

SEMICONDUCTORS

IC704-IC708,IC801,IC802	BA4560F
IC703	BU4053BCF
IC803	BU4066BCF
IC301	CXD2046Q
IC702	LH5P832N-12
IC621	NJM2209S
IC701	PM0007A
IC901	TC74HC157AF
IC620	TC74HC4052AF
IC650	TC7W00F
Q402,Q404,Q407,Q411,Q414	2PB709A
Q645,Q672	2PB709A
Q401,Q403,Q412,Q413	2PD601A
Q600-Q603,Q626,Q636	2PD601A
Q646,Q647,Q655-Q658	2PD601A
Q661,Q662,Q671,Q680,Q681	2PD601A
Q408-Q410,Q415,Q416	2SC1740S
Q703,Q757,Q803	2SD2114K
Q417,Q420,Q651,Q705,Q755	PDTA124EK
Q802,Q806	PDTA124EK
Q418,Q419,Q652,Q694	PDTC124EK
Q701,Q702,Q704,Q756,Q801	PDTC124EK
D650,D655	1SS355
D701-D703,D706	DA204K
D707	UDZS5.6B

COILS

L401-L403	LAU220J
L671	LAU4R7J
L702	LFA220J
L600	LFA221J
L701	LFA3R9J

CAPACITORS

C433	CCSQCH100D50
C655,C722,C729	CCSQCH101J50
C714,C715	CCSQCH102J50
C603	CCSQCH151J50
C731	CCSQCH181J50
C206,C401,C404,C602	CCSQCH220J50
C604	CCSQCH221J50
C791,C792	CCSQCH331J50
C672,C751-C755	CCSQCH390J50
C671	CCSQCH391J50
C405	CCSQCH470J50
C403	CCSQCH560J50
C712,C719	CCSQCH680J50
C805	CCSQCH681J50
C402	CCSQCH6R0D50
C411	CCSQCH910J50
C809,C810	CEAL100M16
C607,C629,C639	CEANP220M10
C656,C737,C744,C806	CEAT100M50
C212,C214,C216,C301,C305	CEAT101M10
C309,C311,C317,C319,C422	CEAT101M10
C424,C426,C429,C436,C438	CEAT101M10
C739,C763,C764,C768	CEAT101M10
C431,C434	CEAT221M10

Mark	No.	Description	Part No.
------	-----	-------------	----------

C723,C730	CEAT2R2M50
C600,C713,C718	CEAT470M10
C767	CEAT471M6R3
C303	CKSQYB102K50
C605	CKSQYB103K50
C620,C632	CKSQYB104K25
C740	CKSQYB122K50
C804	CKSQYB154K16
C710,C721,C724,C733	CKSQYB223K50
C803	CKSQYB273K50
C711,C720	CKSQYB332K50
C606,C732	CKSQYB472K50
C703-C705,C716,C717,C734	CKSQYF103Z50
C743,C745-C749,C765	CKSQYF103Z50
C801,C802,C807,C808	CKSQYF103Z50
C213,C215,C217,C302,C304	CKSQYF104Z25
C306-C308,C310,C312-C316	CKSQYF104Z25
C318,C320-C322,C406,C407	CKSQYF104Z25
C413,C414,C423,C425	CKSQYF104Z25
C427,C428,C430,C432,C435	CKSQYF104Z25
C437,C439,C442,C601,C608	CKSQYF104Z25
C622,C626-C628,C636,C638	CKSQYF104Z25
C660,C702,C708,C709,C741	CKSQYF104Z25
C761,C762,C766,C769,C793	CKSQYF104Z25
C811,C812,C901	CKSQYF104Z25
C706,C707	CKSQYF105Z16

RESISTORS

R424	RN1/10SE1801D
R422	RN1/10SE2201D
R309	RN1/10SE2700D
R425	RN1/10SE2702D
R310,R420,R421	RN1/10SE3301D
R312,R426,R814,R815,R818	RN1/10SE4701D
R820	RN1/10SE4701D
R311	RN1/10SE5601D
R705,R706,R711,R712	RS1/10S1001F
R718,R719,R721,R722	RS1/10S1001F
VR301 (22kΩ)	PCP1030
Other Resistors	RS1/10S□□□□

OTHERS

CN703	21P FFC CONNECTOR	52045-2145
CN701	24P FFC CONNECTOR	52045-2445
CN601	KR CONNECTOR	B13B-PH-K-S
CN702	KR CONNECTOR	B6B-PH-K-S
CN101	CONNECTOR 16P	BTFN16P-3RD7
CN102	CONNECTOR 20P	BTFN20P-3RD7
JA701	AUDIO 2P PIN JACK	RKB1041
JA101	2P PIN JACK	VKB1064
JA102	4P DIN SOCKET	VKN1072

R MSWB ASSY

CAPACITORS

△ C1101 (4700pF/AC250V)	ACG7009
-------------------------	---------

OTHERS

△ S1101 PUSH SWITCH	ASG1006
---------------------	---------

6. ADJUSTMENT

6.1 ADJUSTMENT ITEMS AND LOCATION

■ Adjustment Items

[Mechanical Part]

CLD

- ① Tilt Offset Adjustment
- ② Tangential Direction Angle Adjustment for Side A
- ③ Spindle Motor Centering Adjustment for Side A
- ④ Crosstalk Check and Fine Tilt Offset Adjustment for Side A
- ⑤ Focus Servo Loop Gain Adjustment
- ⑥ Tracking Servo Loop Gain Adjustment
- ⑦ Tangential Direction Angle Adjustment for Side B
- ⑧ Spindle Motor Centering Adjustment for Side B
- ⑨ Crosstalk Check and Fine Tilt Offset Adjustment for Side B

DVD

- ⑩ RF MAX Adjustment
- ⑪ DVD Jitter Best Adjustment

[Electrical Part]

CLDM ASSY

- ① Video Level Adjustment
- ② 18MHz Master Clock Adjustment

DVDM ASSY

- ① VCO Offset Adjustment
- ② Video Output Level Adjustment

KYCB ASSY

- ① Y Output Level Adjustment

■ Adjustment Points (PCB Part)

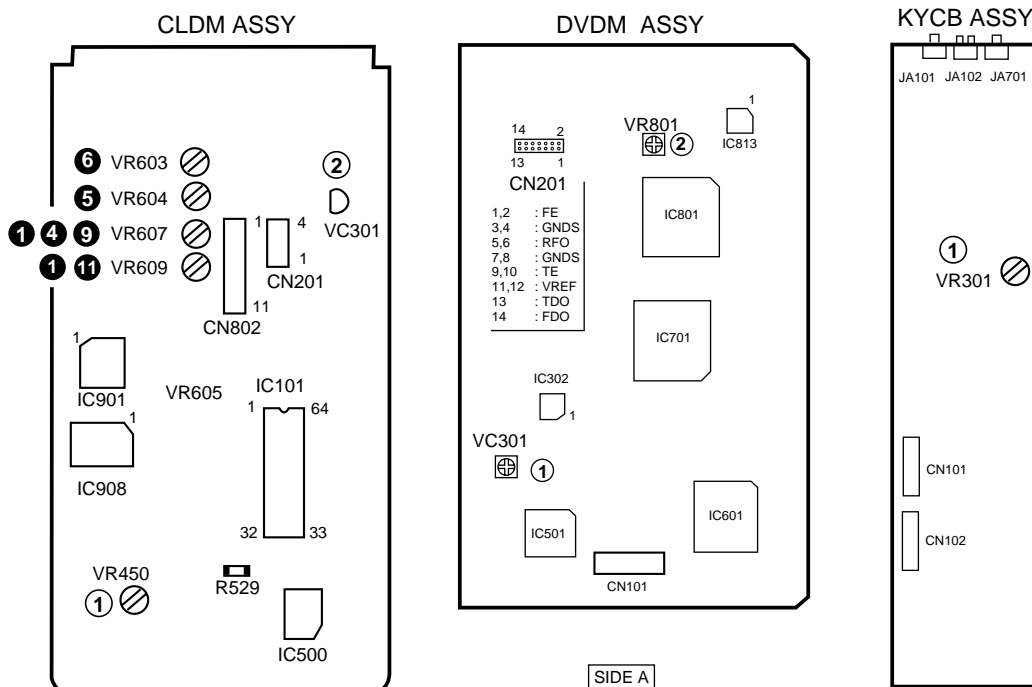

■ Adjustment Points (Mechanism Part)

CLD

[Side A]

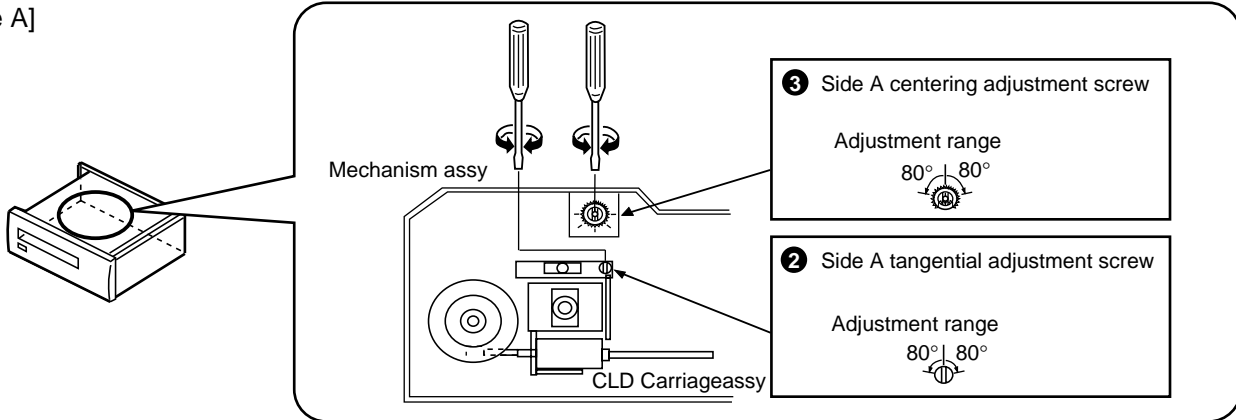

[Side B]

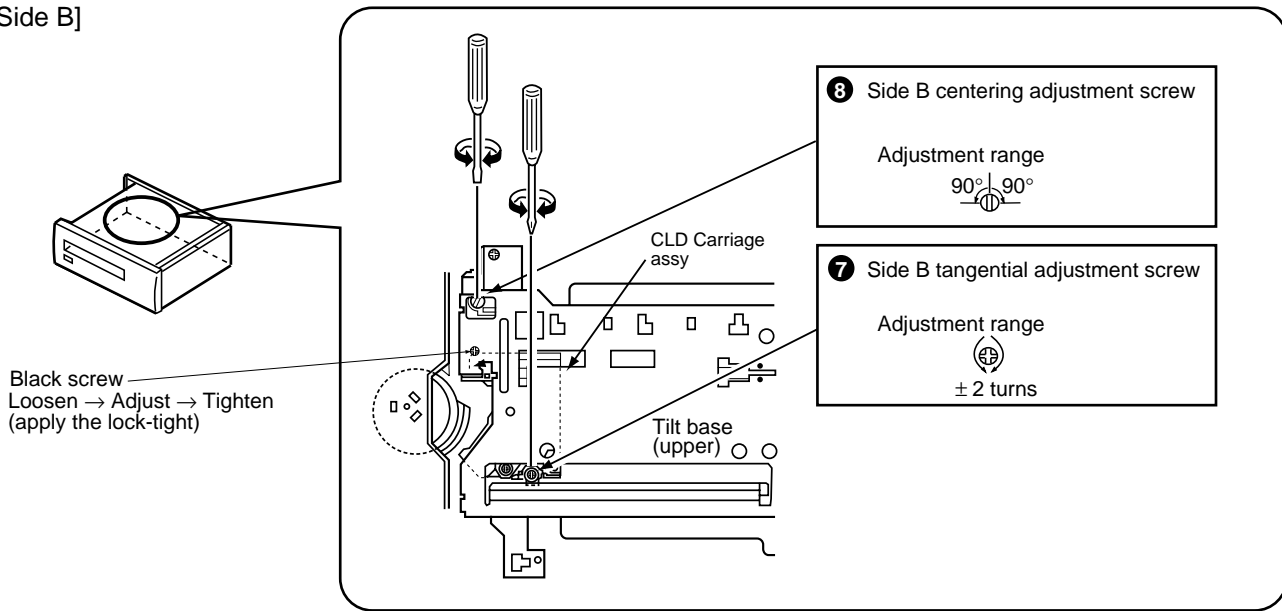



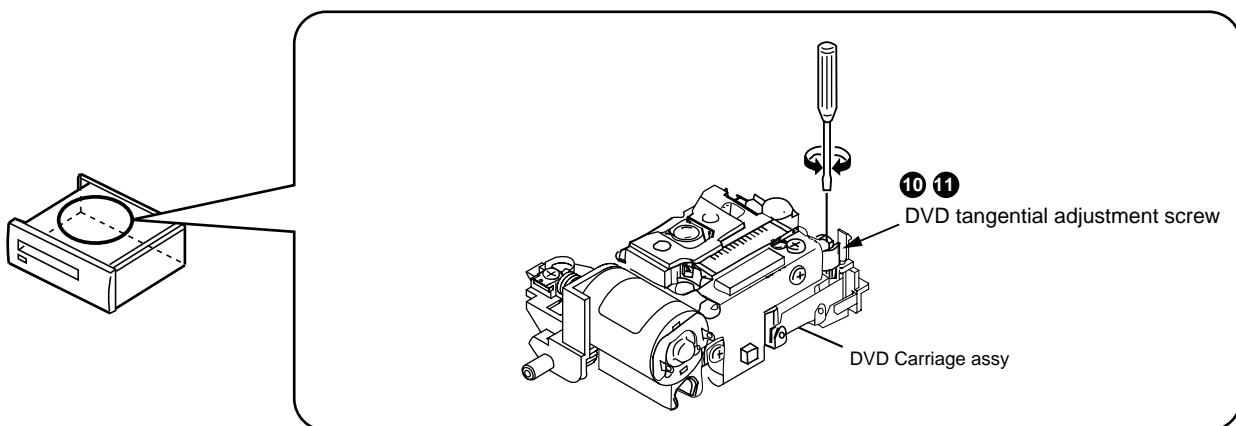





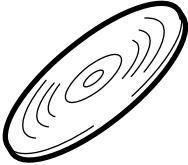

DVD

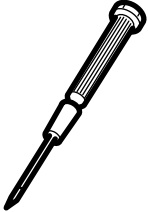
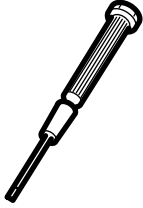

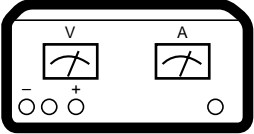
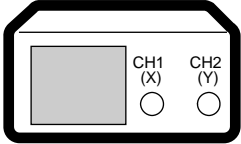
Note : Apply the lock-tight.

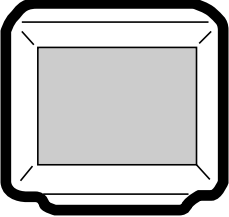
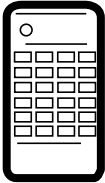
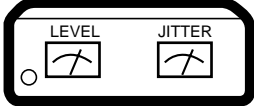
6.2 JIGS AND MEASURING INSTRUMENTS

 <p>CD test disc (YEDS-7)</p>	 <p>LD test disc (GGV1012)</p>	 <p>DVD test disc (DVD-MJK1)</p>	 <p>⊖ Screwdriver (medium)</p>
 <p>⊖ Screwdriver (small)</p>	 <p>⊕ Precise screwdriver</p>	 <p>⊖ Precise screwdriver</p>	 <p>⊕ Screwdriver (large)</p>
 <p>⊕ Screwdriver (medium)</p>	 <p>DC power supply</p>	 <p>Dual-trace oscilloscope (with delay) Frequency band $\geq 40\text{MHz}$</p>	 <p>Frequency counter Display digit $\geq 8\text{-digit}$</p>
 <p>TV monitor</p>	 <p>Test mode remote control unit (GGF1067)</p>	 <p>Jitter meter</p>	 <p>Equalizer unit</p>

6.3 TEST MODE

TEST MODE: ON

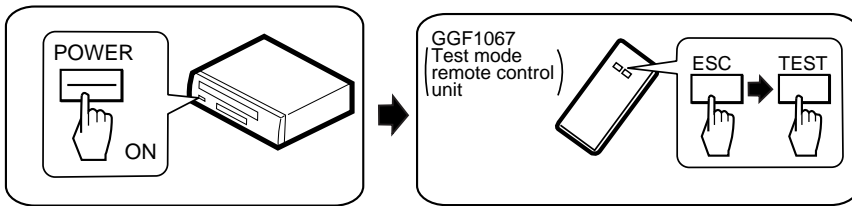

TEST MODE: DISC SET

• With TRAY

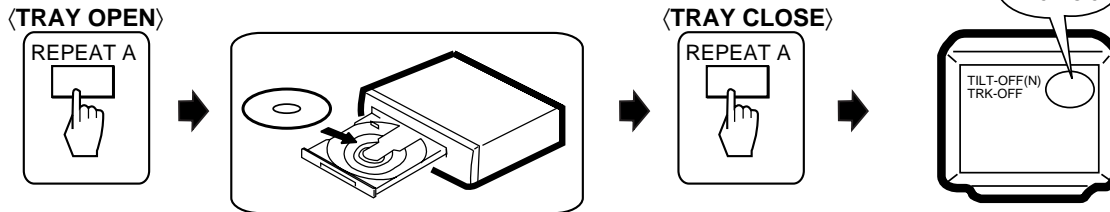

• No TRAY

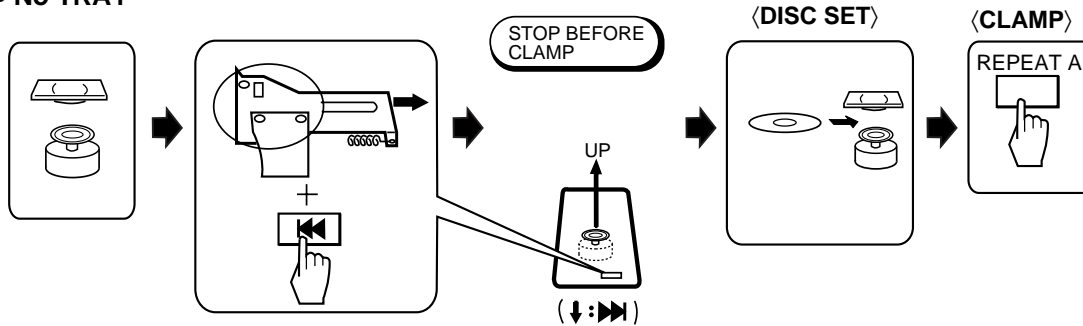

TEST MODE: PLAY

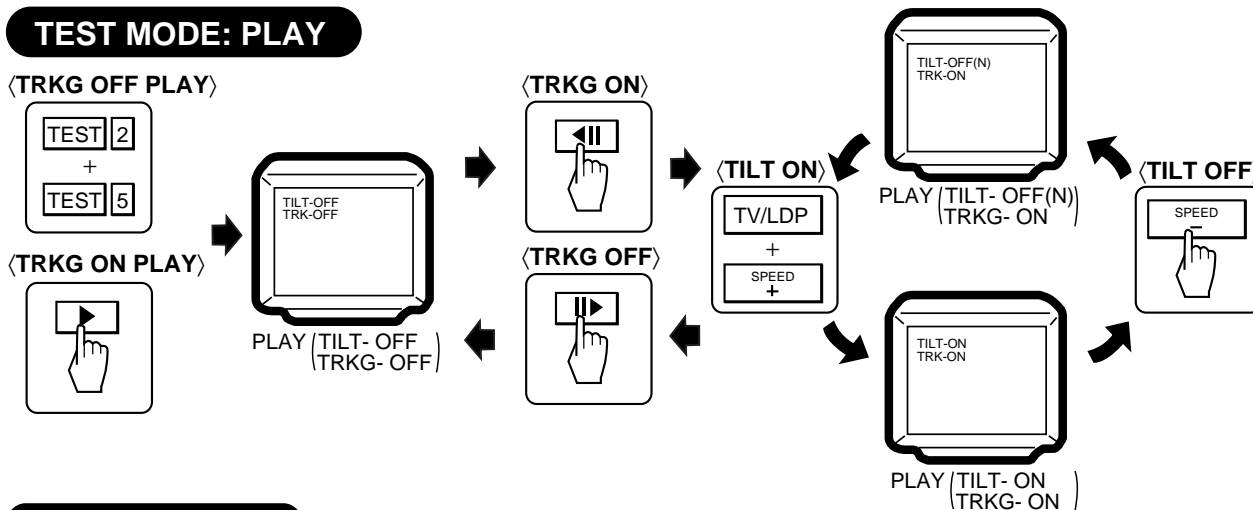

TEST MODE: OFF

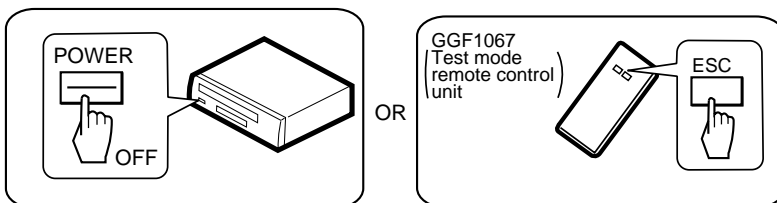

6.4 NECESSARY ADJUSTMENT POINTS

When	Adjustment Points				
■ EXCHANGE MECHANISM ASSY PARTS					
Exchange pickup (CLD)	<table border="1" style="width: 100%;"> <tr> <td style="width: 30%;">Mechanical point</td> <td>①, ②, ③, ④, ⑤, ⑥, ⑦, ⑧, ⑨</td> </tr> <tr> <td>Electric point</td> <td>_____</td> </tr> </table>	Mechanical point	①, ②, ③, ④, ⑤, ⑥, ⑦, ⑧, ⑨	Electric point	_____
Mechanical point	①, ②, ③, ④, ⑤, ⑥, ⑦, ⑧, ⑨				
Electric point	_____				
Exchange pickup (DVD)	<table border="1" style="width: 100%;"> <tr> <td style="width: 30%;">Mechanical point</td> <td>⑩, ⑪</td> </tr> <tr> <td>Electric point</td> <td>_____</td> </tr> </table>	Mechanical point	⑩, ⑪	Electric point	_____
Mechanical point	⑩, ⑪				
Electric point	_____				
Exchange spindle motor	<table border="1" style="width: 100%;"> <tr> <td style="width: 30%;">Mechanical point</td> <td>③, ⑧</td> </tr> <tr> <td>Electric point</td> <td>_____</td> </tr> </table>	Mechanical point	③, ⑧	Electric point	_____
Mechanical point	③, ⑧				
Electric point	_____				
■ EXCHANGE PCB ASSY					
Exchange board CLDM ASSY	<table border="1" style="width: 100%;"> <tr> <td style="width: 30%;">Mechanical point</td> <td>①, ④, ⑤, ⑥, ⑨</td> </tr> <tr> <td>Electric point</td> <td>_____</td> </tr> </table> <p style="text-align: center;">Note : ① and ② are adjusted already.</p>	Mechanical point	①, ④, ⑤, ⑥, ⑨	Electric point	_____
Mechanical point	①, ④, ⑤, ⑥, ⑨				
Electric point	_____				
Exchange board DVDM ASSY	<table border="1" style="width: 100%;"> <tr> <td style="width: 30%;">Mechanical point</td> <td>_____</td> </tr> <tr> <td>Electric point</td> <td>_____</td> </tr> </table> <p style="text-align: center;">Note : ① and ② are adjusted already.</p>	Mechanical point	_____	Electric point	_____
Mechanical point	_____				
Electric point	_____				
Exchange board KYCB ASSY	<table border="1" style="width: 100%;"> <tr> <td style="width: 30%;">Mechanical point</td> <td>_____</td> </tr> <tr> <td>Electric point</td> <td>_____</td> </tr> </table> <p style="text-align: center;">Note : ① is adjusted already.</p>	Mechanical point	_____	Electric point	_____
Mechanical point	_____				
Electric point	_____				

6.5 MECHANICAL ADJUSTMENT

1 Tilt Offset Adjustment

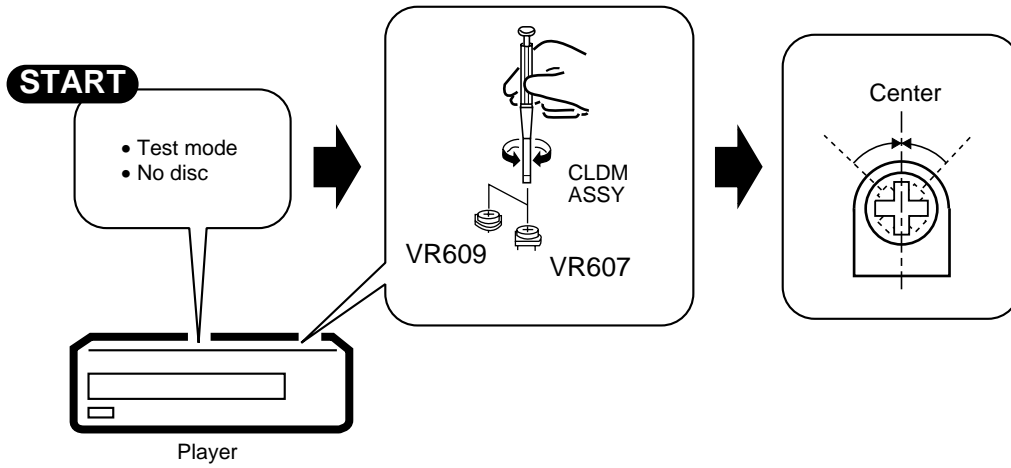

2 Tangential Direction Angle Adjustment for Side A

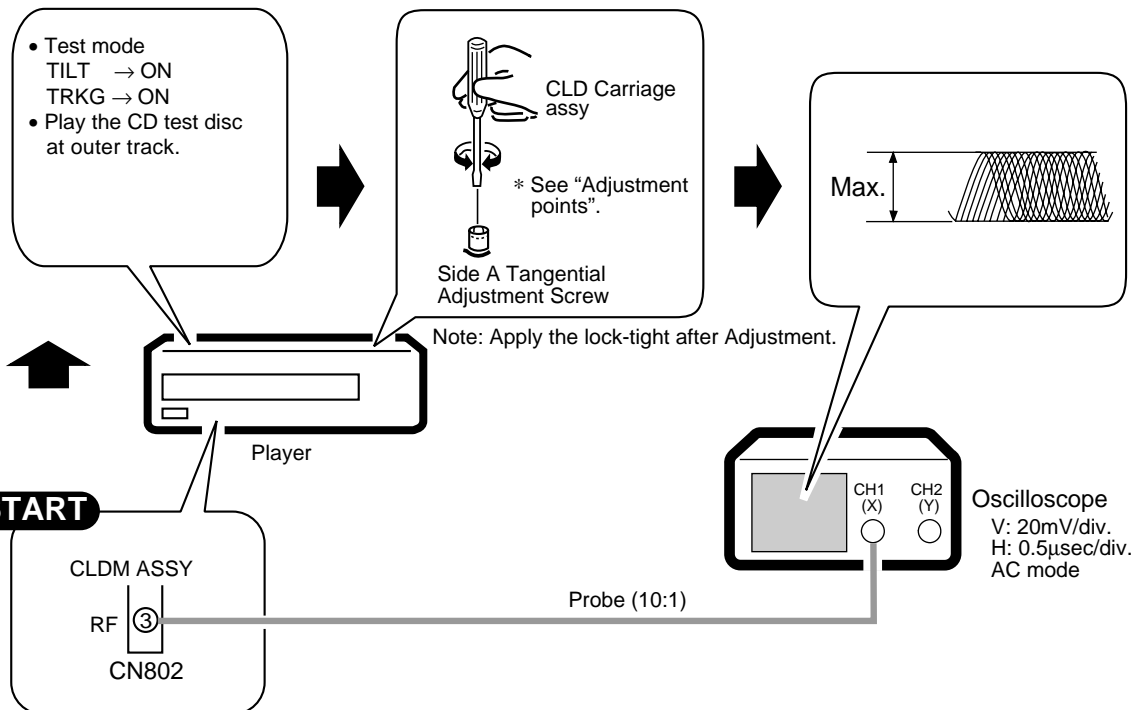

3 Spindle Motor Centering Adjustment for Side A

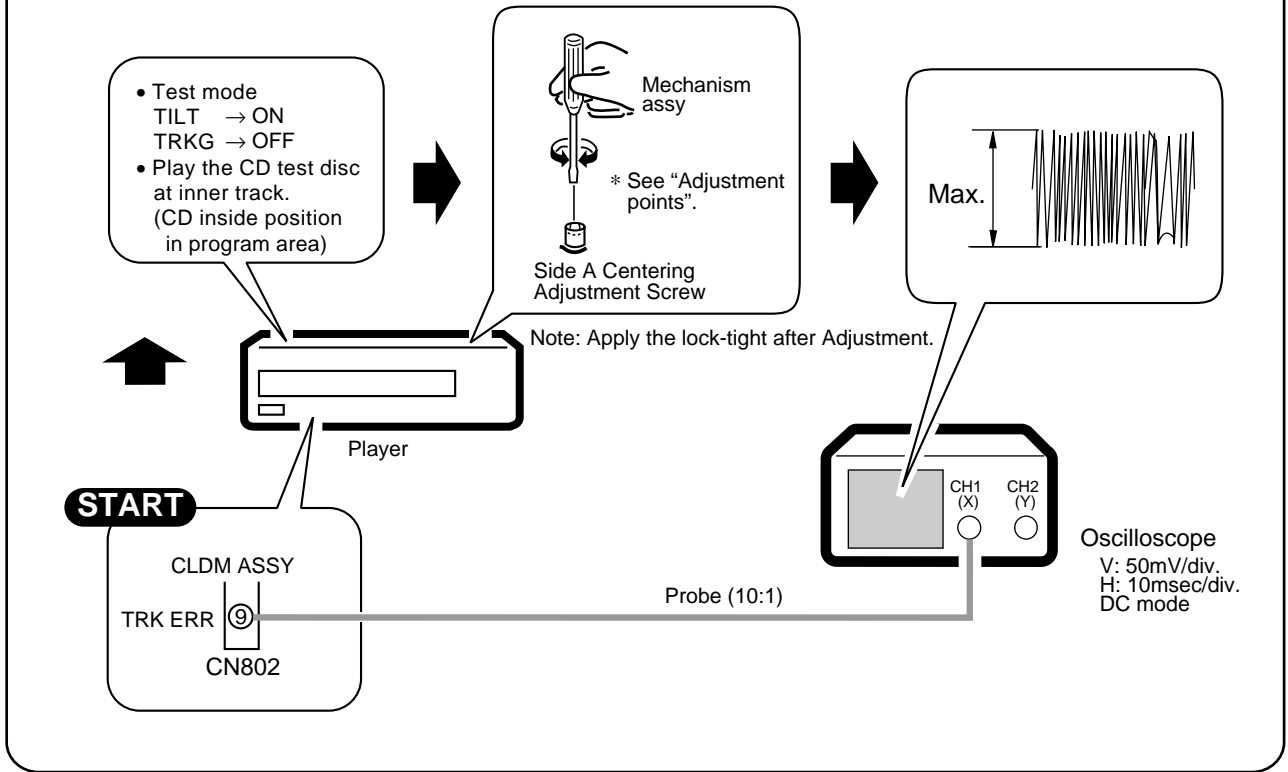

4 Crosstalk Check and Fine Tilt Offset Adjustment for Side A

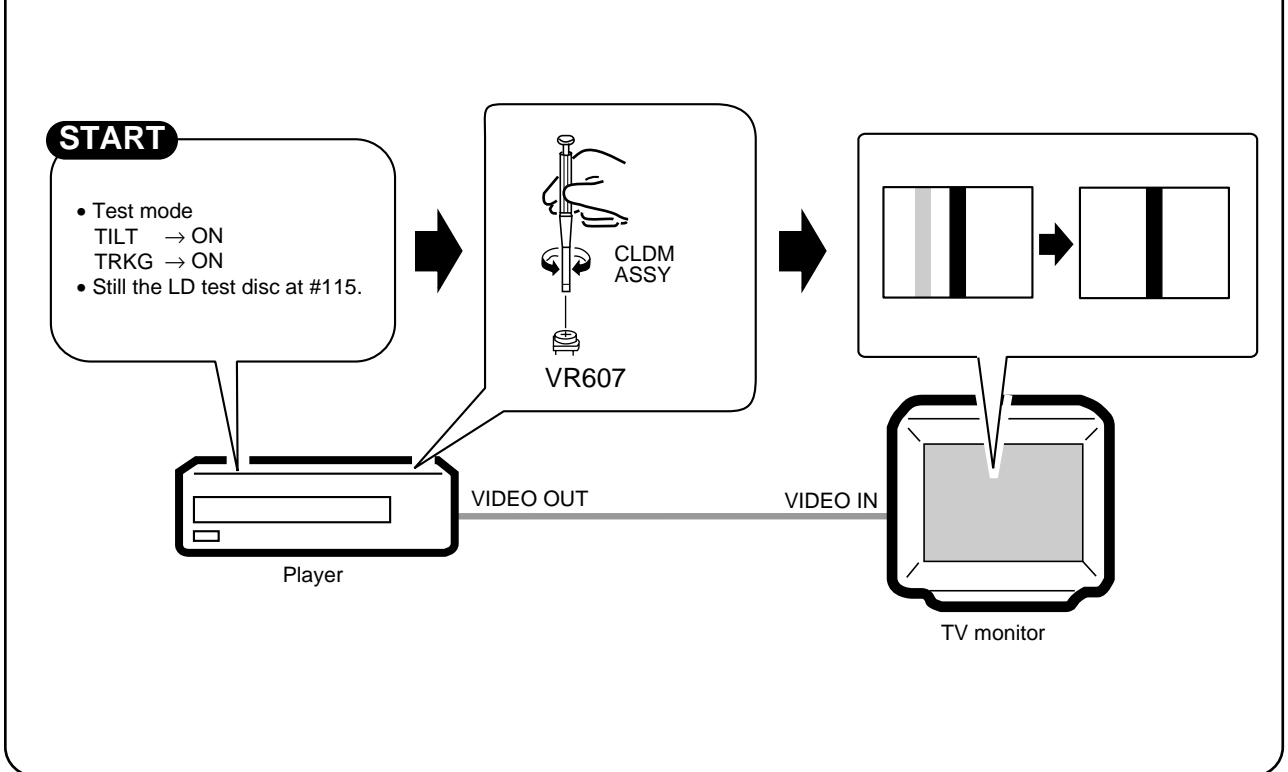

5 Focus Servo Loop Gain Adjustment

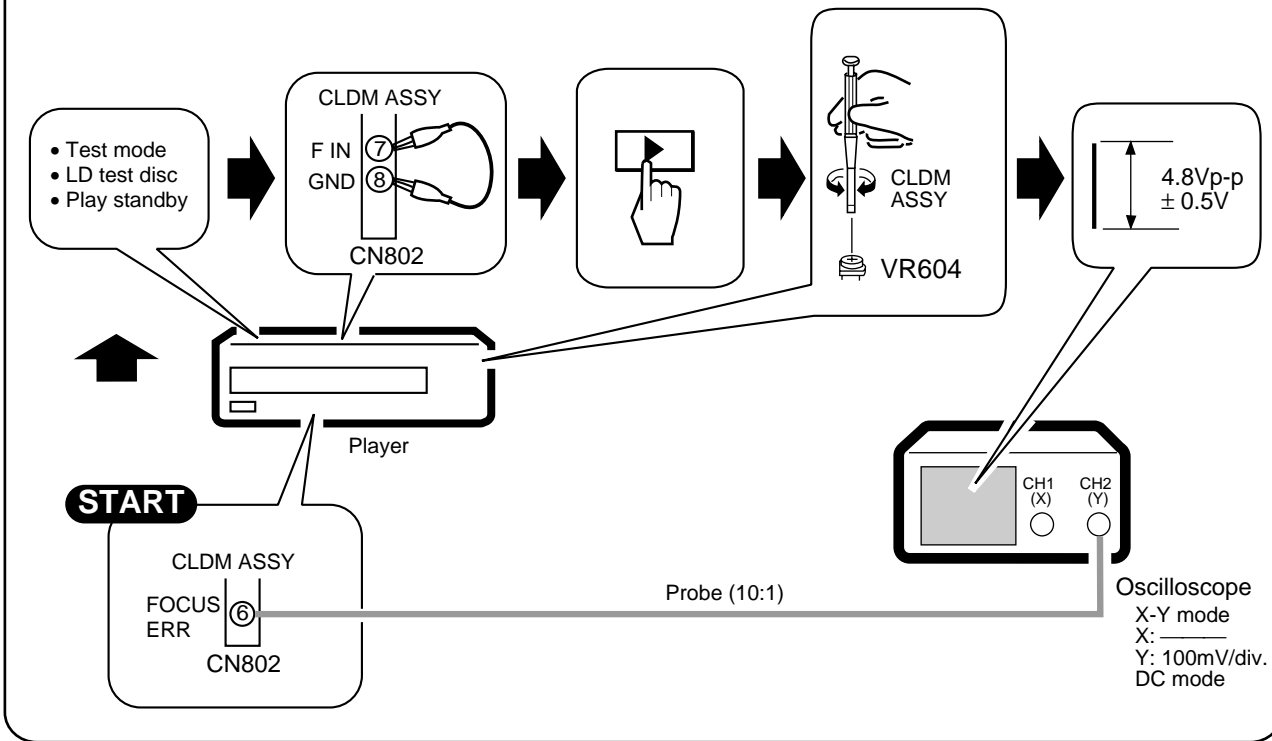

6 Tracking Servo Loop Gain Adjustment

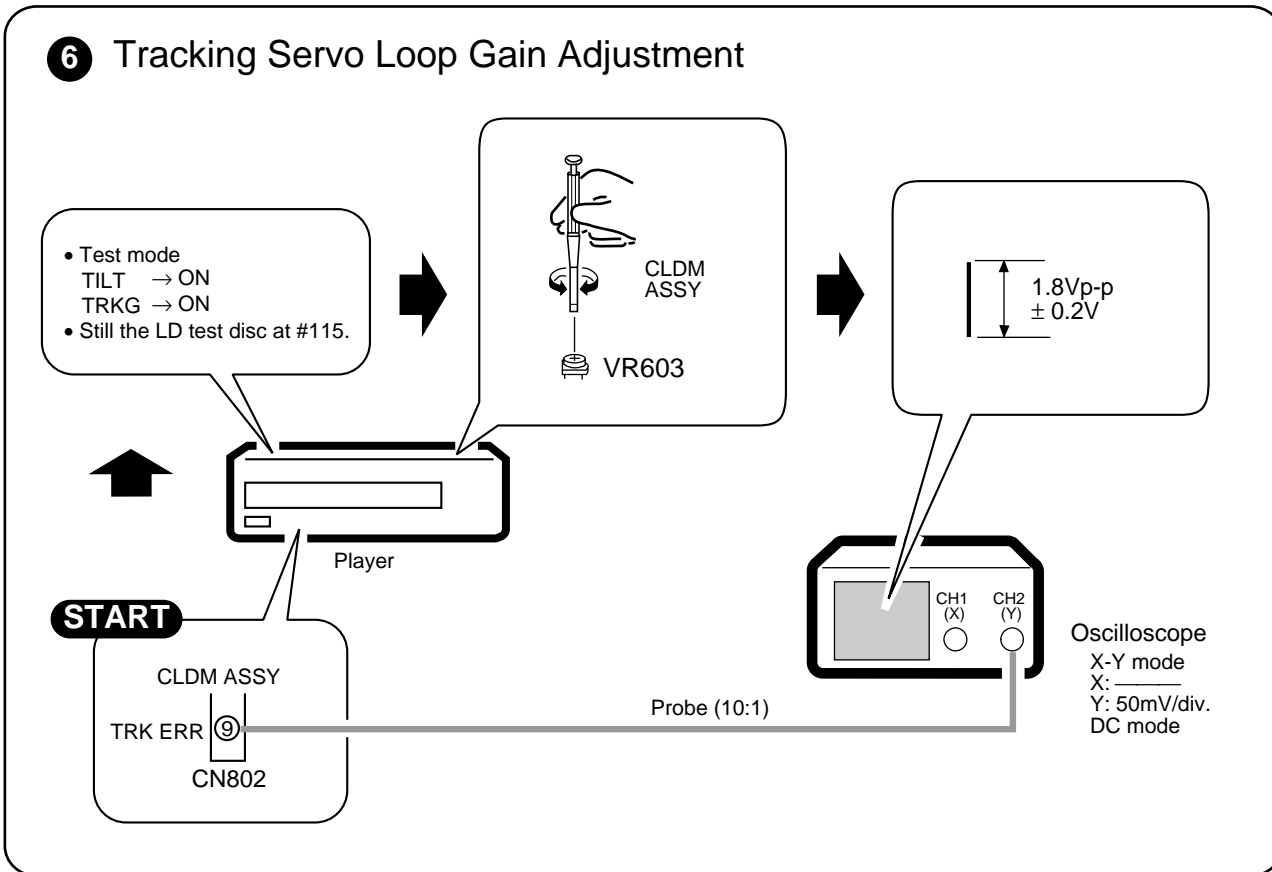

7 Tangential Direction Angle Adjustment for Side B

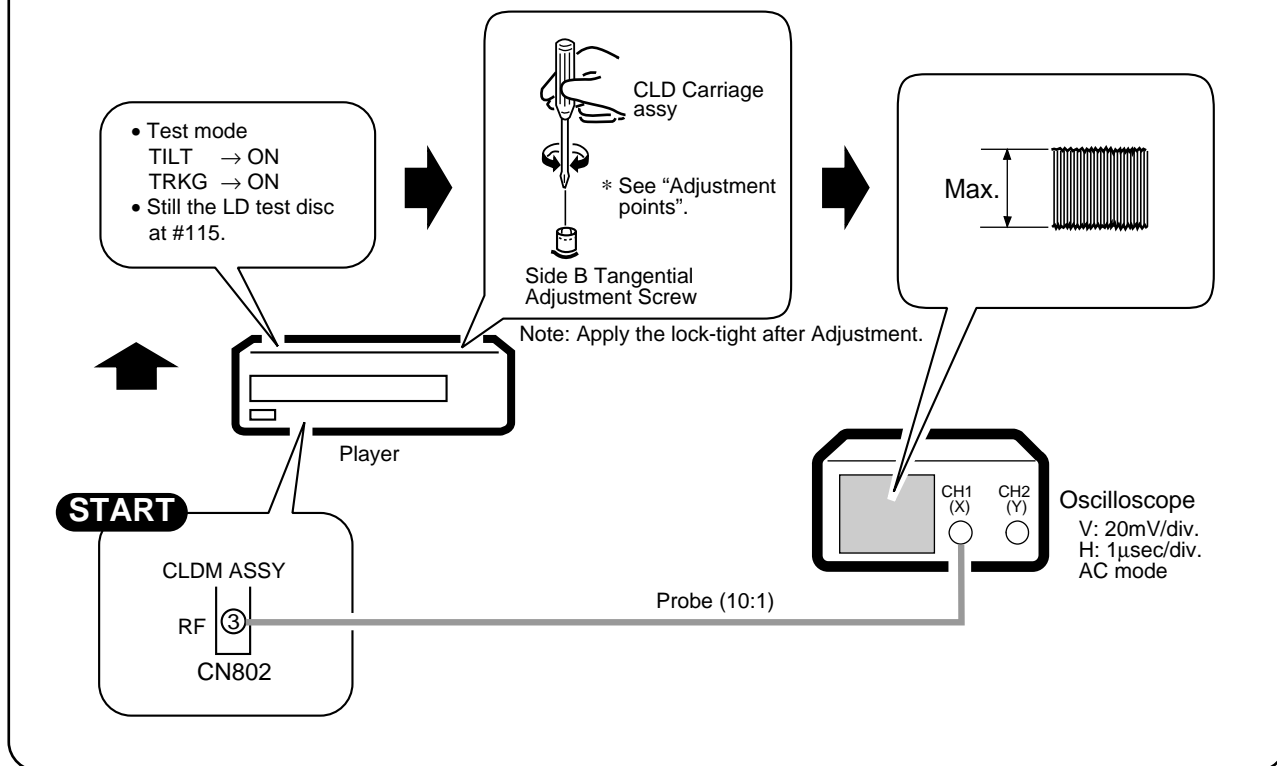

8 Spindle Motor Centering Adjustment for Side B

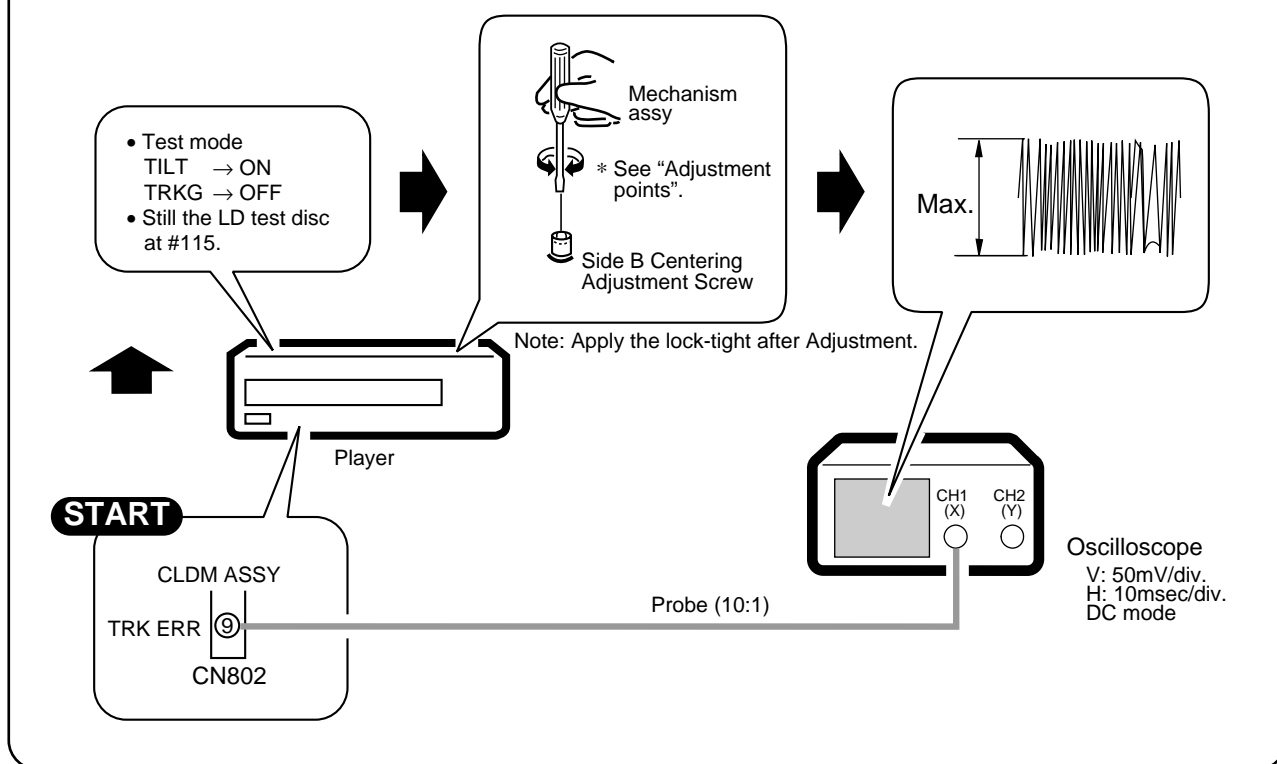

9 Crosstalk Check and Fine Tilt Offset Adjustment for Side B

START

- Test mode
TILT → ON
TRKG → ON
- Still the LD test disc at #115.

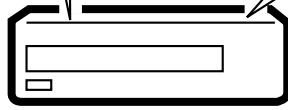
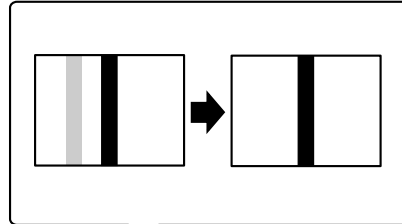
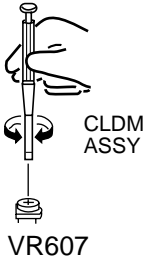

Player

VIDEO OUT

VIDEO IN

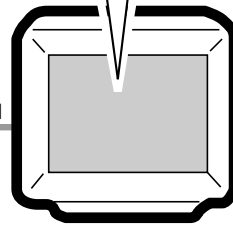

10 RF Max Adjustment

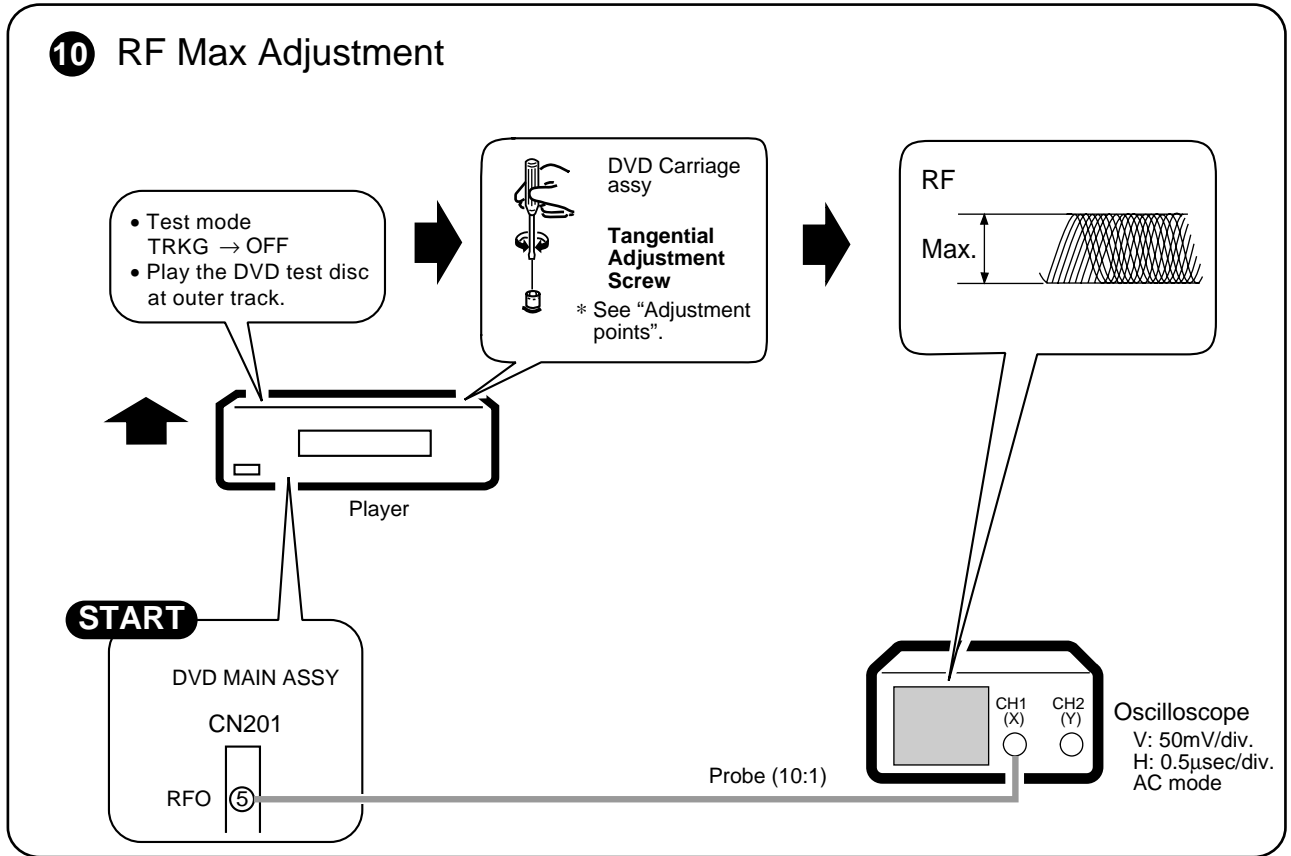

11 DVD Jitter Best Adjustment

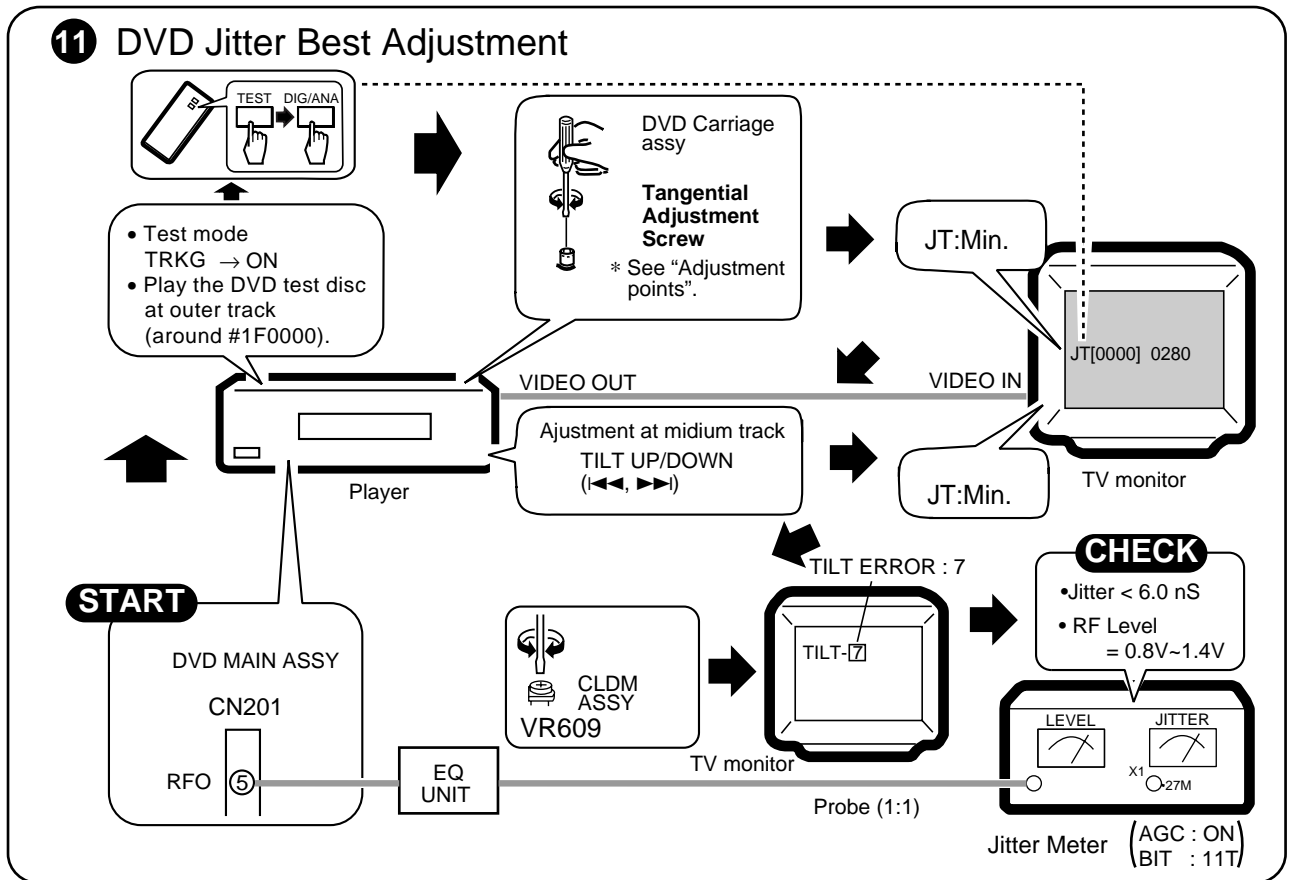

6.6 ELECTRICAL ADJUSTMENT FOR CLDM ASSY

① Video Level Adjustment

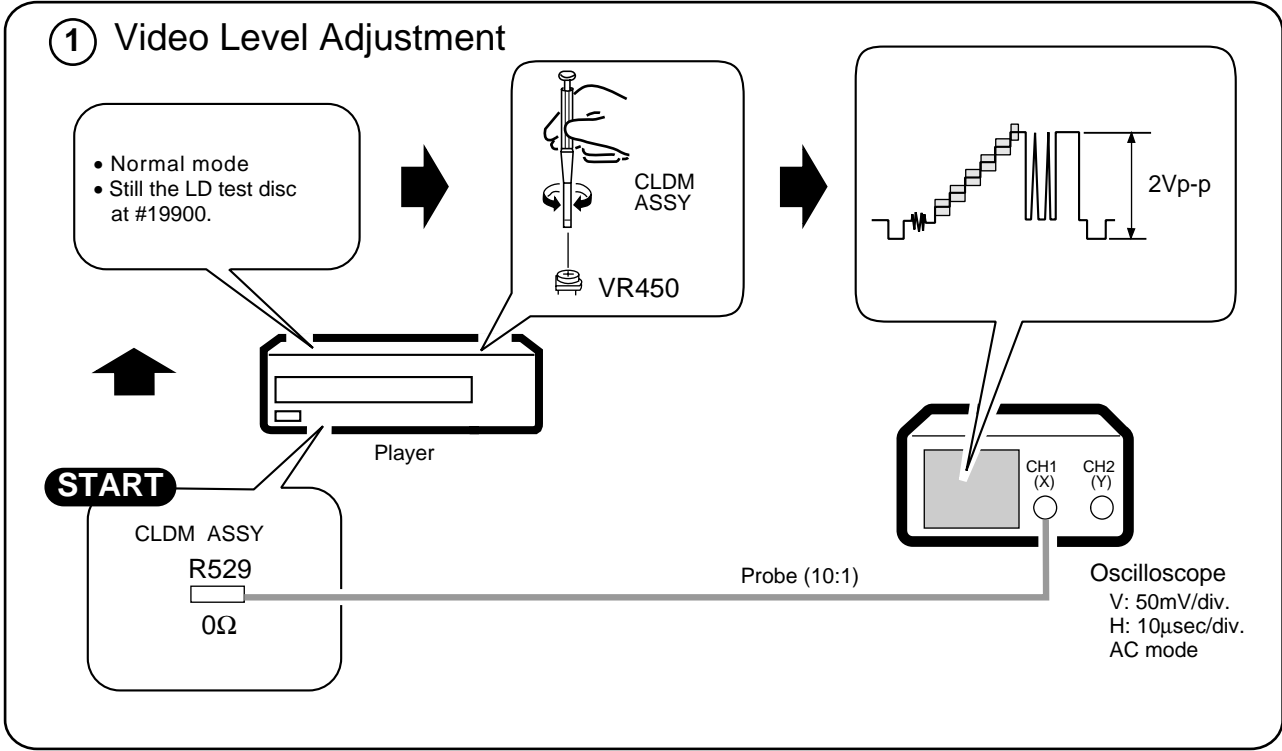

② 18MHz Master Clock Adjustment

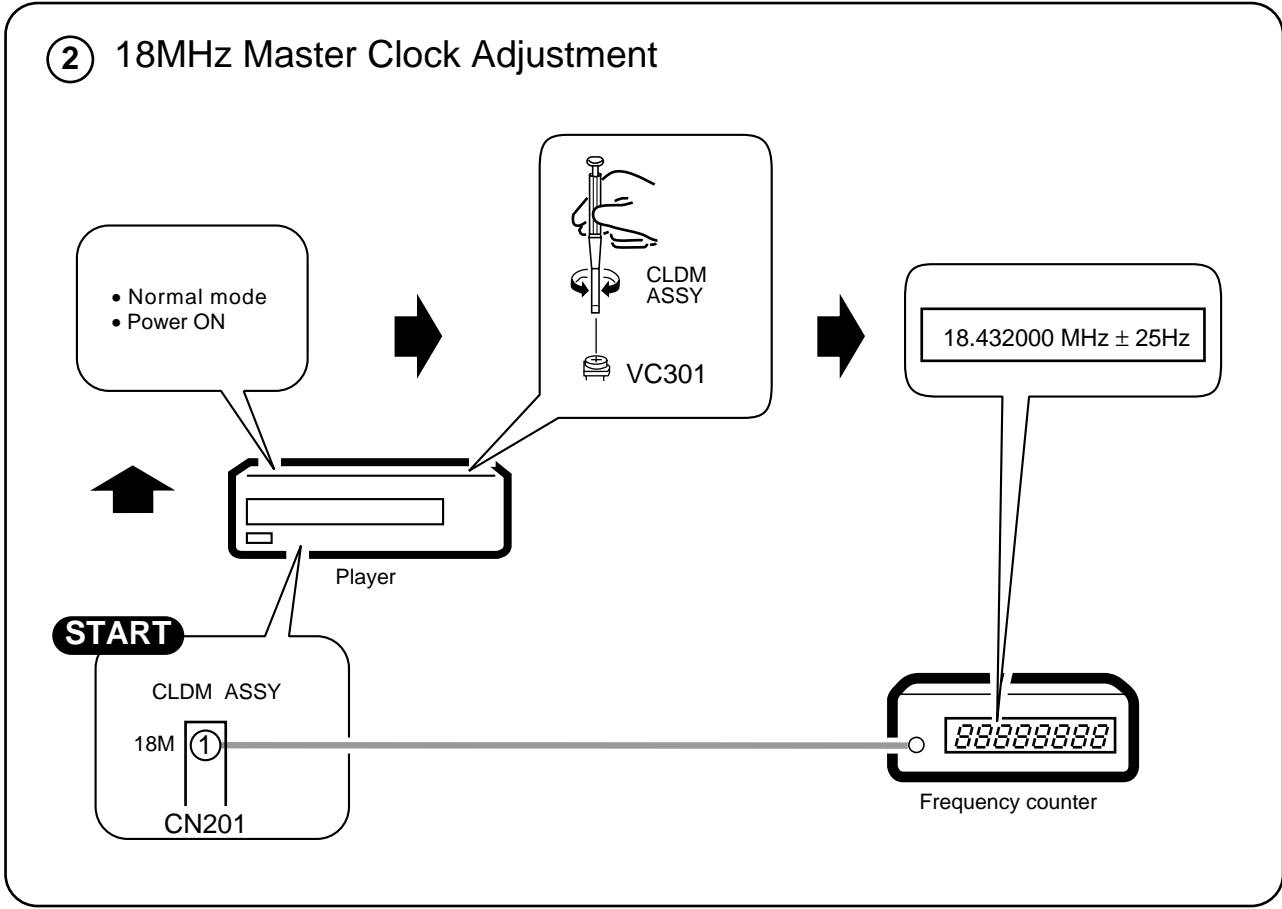

6.7 ELECTRICAL ADJUSTMENT FOR DVDM ASSY

① VCO Offset Adjustment

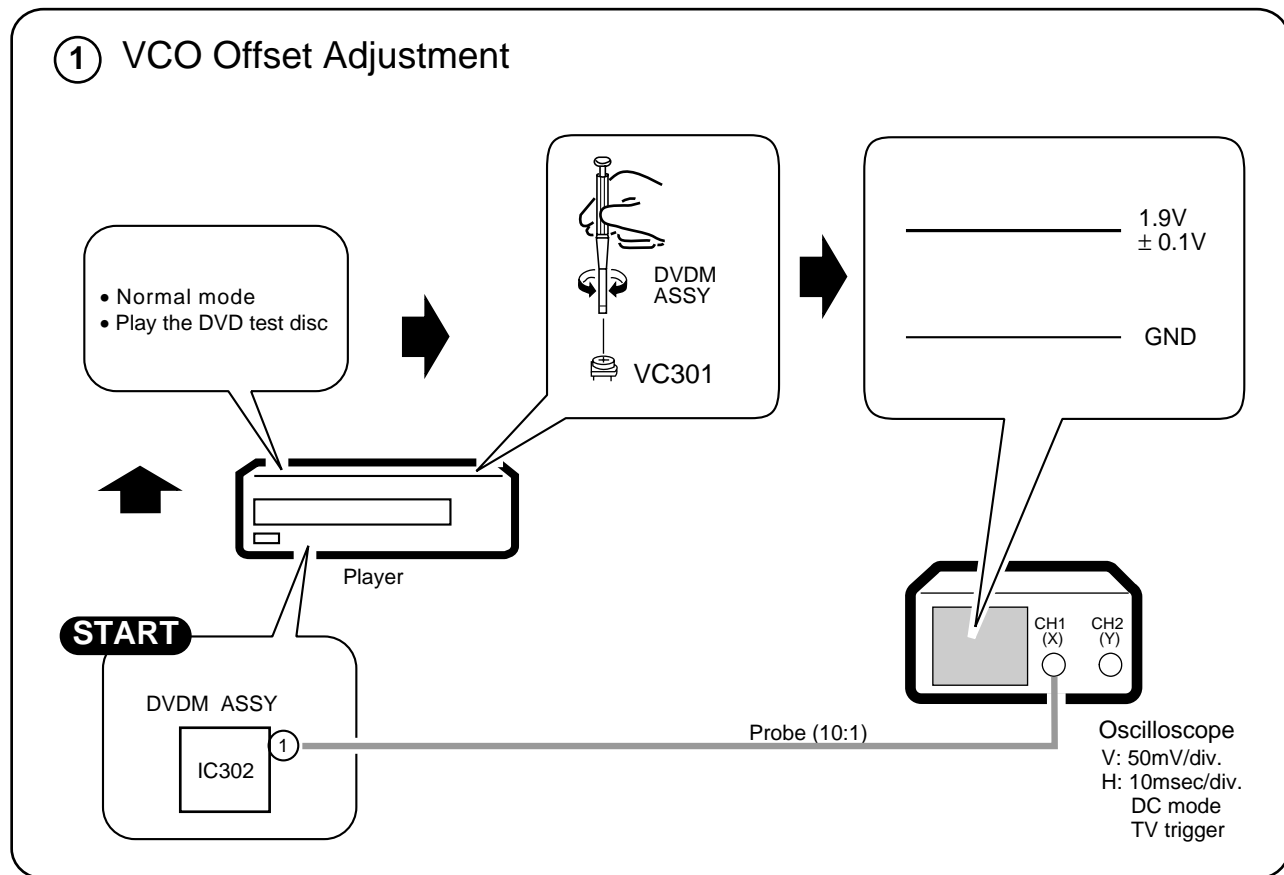

② Video Output Level Adjustment

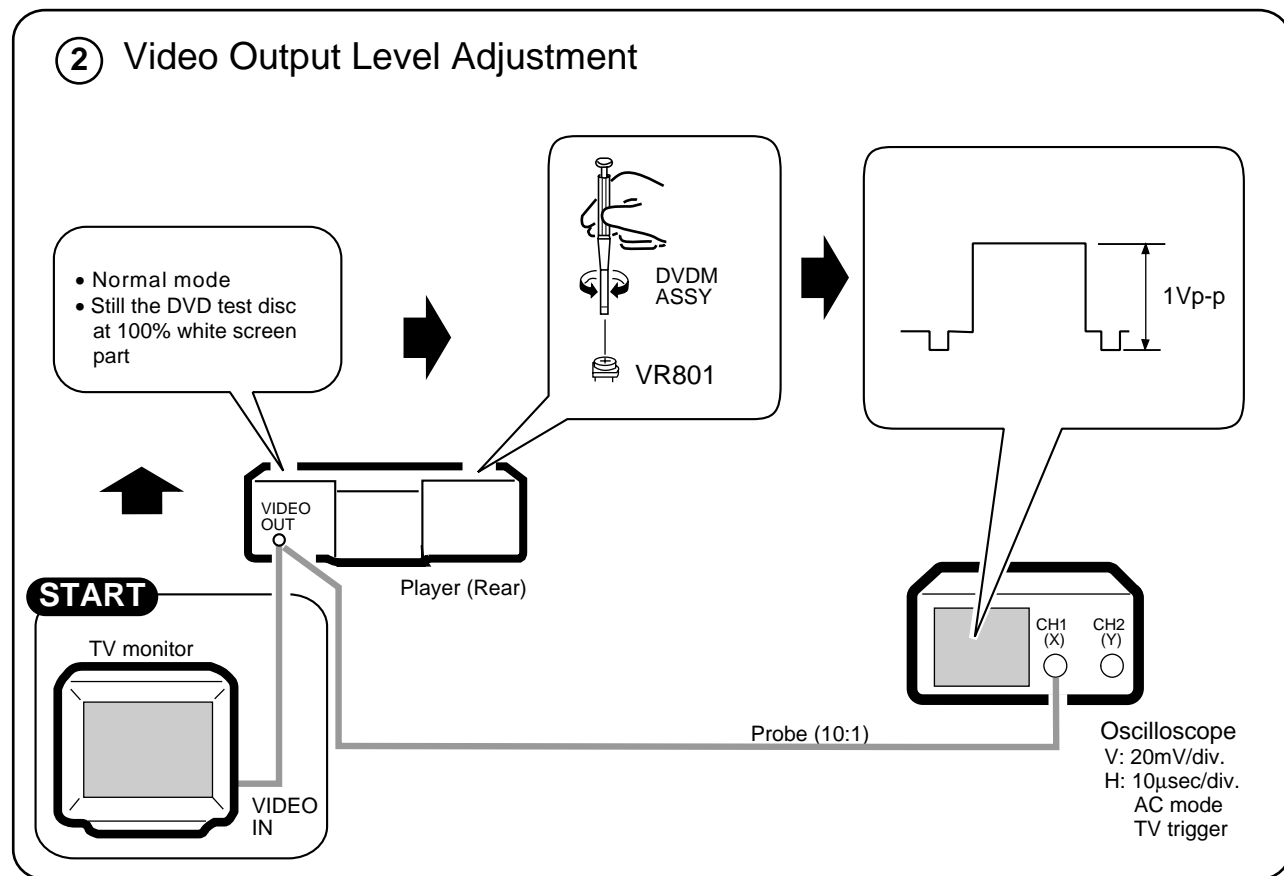

6.8 ELECTRICAL ADJUSTMENT FOR KYCB ASSY

① Y Output Level Adjustment

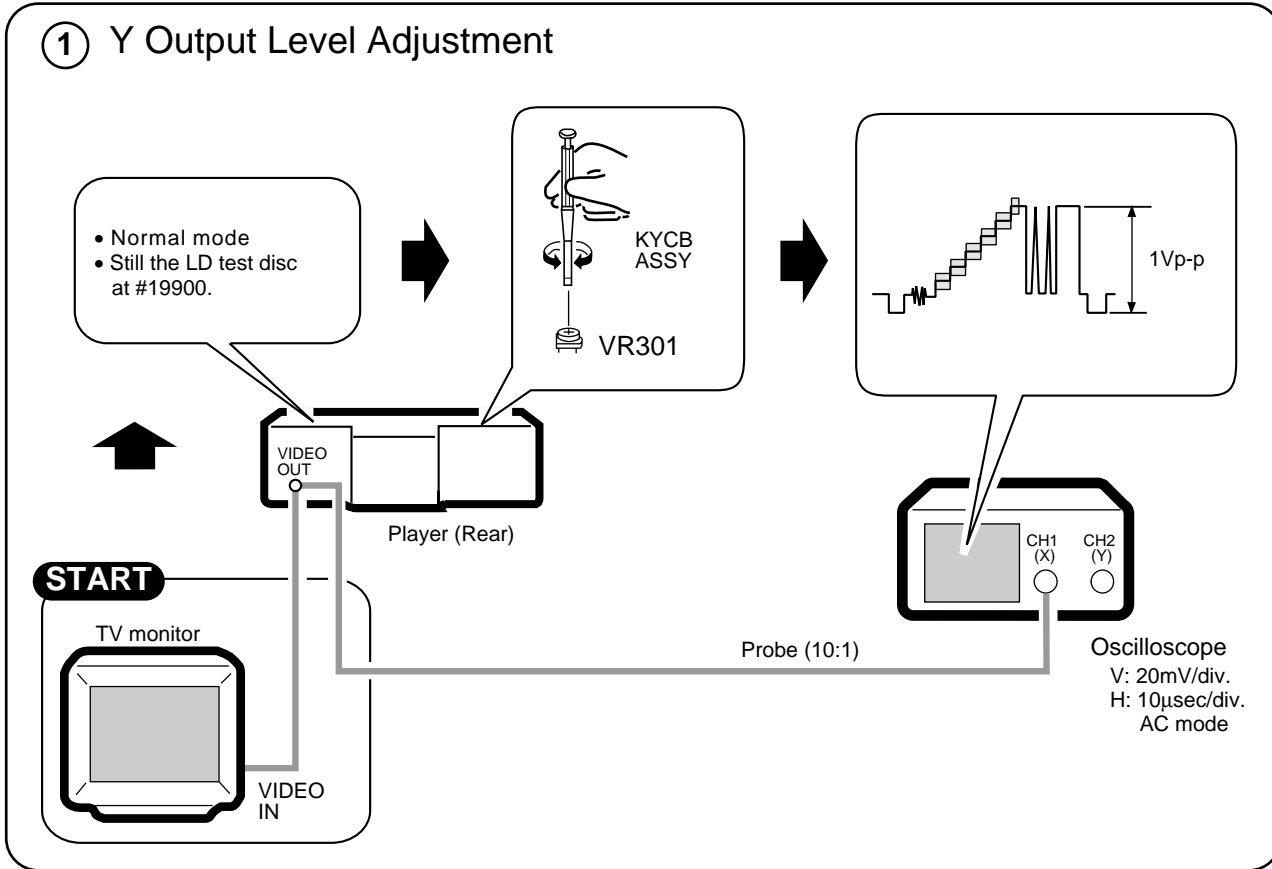

6.9 OPERATIONS IN THE TEST MODE

■ Test Mode Remote Control Unit (GGF1067)

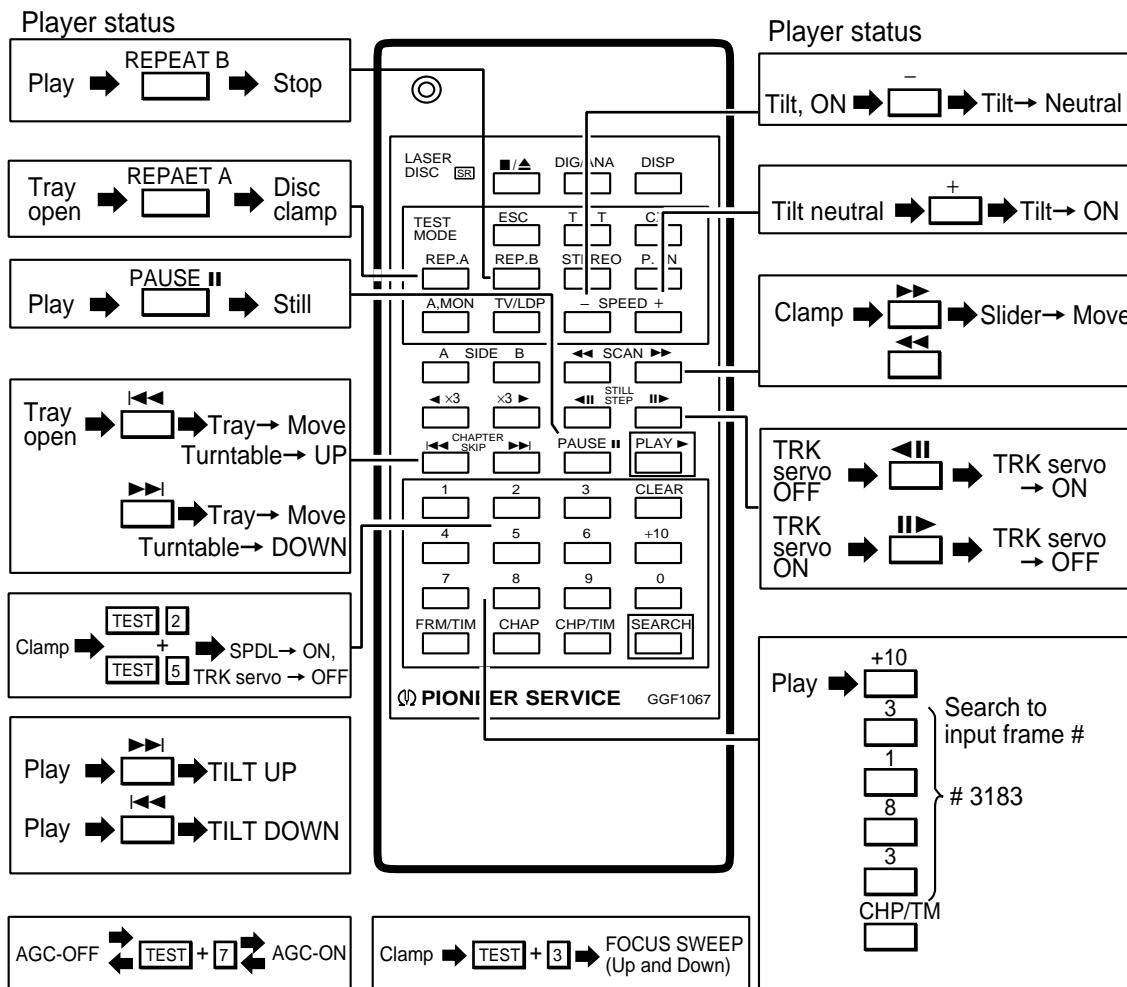

■ TV Monitor Display

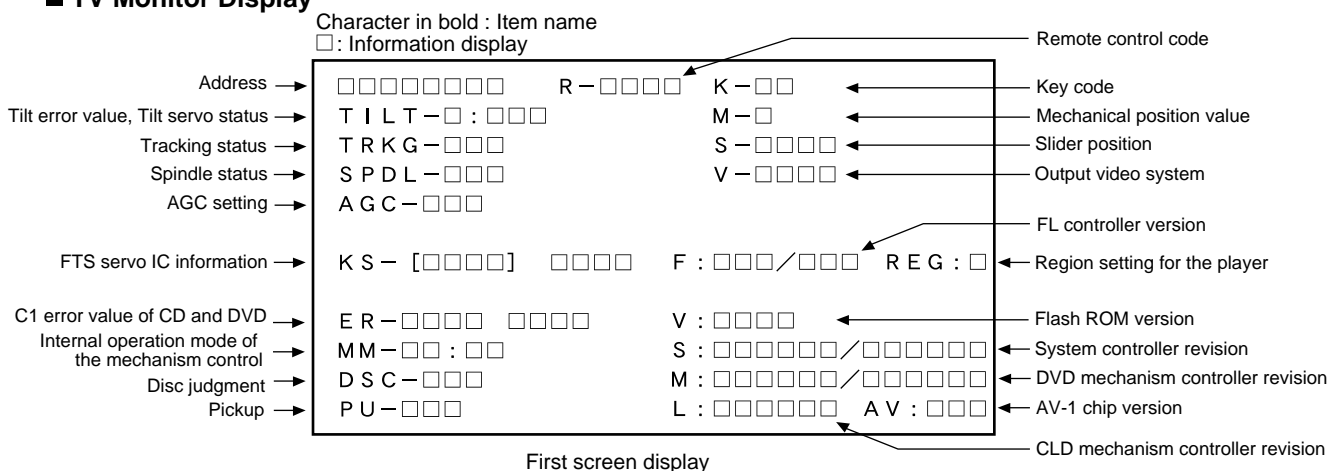

Note : Switch the first and second screen by pressing the [DISPLAY] key on the remote control unit.

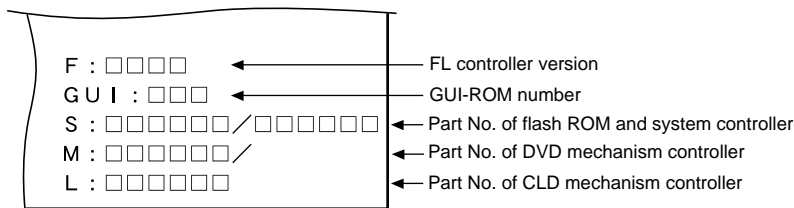

Second screen display (at lower right portion of the screen)

7. GENERAL INFORMATION

7.1 IC

• The information shown in the list is basic information and may not correspond exactly to that shown in the schematic diagrams.

■ PD4929B (FLKY ASSY: IC101)

● Syetem microcomputer for DVD karaoke and Syetem microcomputer for FL

● Pin Function

No.	Pin Name	I/O	Function
1	T6	O	FL grid output
2	T5	O	FL grid output
3	T4	O	FL grid output
4	T3	O	FL grid output
5	T2	O	FL grid output
6	T1	O	FL grid output
7	T0	O	FL grid output
8	Vcc	-	Positive power supply
9	XSCK0	O	Serial communication clock for DSP
10	SO0	O	Serial communication data output for DSP
11	SI0	I	Serial communication data input for DSP
12	LATCH	I	Communication permission input from system microcomputer
13	XREADY	O	Communication request output to system microcomputer
14	XSCK1	(*1)	Serial communication clock for system microcomputer
15	SO1	(*1)	Serial communication data output to system microcomputer
16	SI1	I	Serial communication data input from System microcomputer
17	XRESET IN	I	Reset input
18	I/O CLK	O	Clock output for I/O expander
19	I/O DATA	O	Data output for I/O expander
20	Vss	-	Ground voltage for A/D converter
21	XREXET OUT	O	System reset signal output
22	KEY0	I	Key input (A/D input)
23	KEY1	I	Key input (A/D input)
24	KEY2	I	Key input (A/D input)
25	ECHO VOL	I	Digital echo volume input (A/D input)
26	G.V. VOL	I	Guide vocal sound volume input (A/D input)
27	MIC CONT	I	MIC control input (A/D input)
28	MODEL SELECT	I	Version selector (A/D input)
29	AVDD	-	Analog power supply for A/D converter
30	AVREF	I	Reference voltage input for A/D converter
31	XREQ	I	Data transfer request input from DSP
32	NC	O	Not used
33	Vss	-	Ground voltage
34	X1	I	System clock oscillation connection
35	X2	-	System clock oscillation connection
36	LED(GUIDE V.)	O	Guide vocal sound volume LED (L:lit)
37	A/XD	O	Address/data selector for DSP
38	XDRDY	I	Signal reception ready status input from DSP
39	DSP XCS	O	Chip select output for DSP
40	POWER ON	O	System power ON signal output

No.	Pin Name	I/O	Function
41	DSP THRU	O	DSP thru mode output
42	XBATLLE	O	Karaoke battle output
43	TINT/EXT	O	External/internal voice selection output
44	MIC X1/2	O	Karaoke battle MIC selector
45	XMIC ON	O	MIC ON/OFF selection output
46	V-CD NR	O	Video CD NR selector
47	SEL IR	I	Remote control input
48	IC	-	Internal connection (directly connected to Vcc)
49	SSVC	O	Stereo Scoring voice cancel output
50	MIC SENSE	I	MIC sense input
51	NC	O	Not used
52	VDD	-	Positive power supply
53	LED(KARAOKE)	O	Karaoke LED output
54	LED(SINGLE)	O	Single track stop LED output
55	LED(STANDBY)	O	Standby LED output
56	NC	O	Not used
57	NC	O	Not used
58	NORES	I	H: Reset prohibition L: Reset with communication error
59	CHEKER	I	H: Checker mode
60	MECHA SW	I	H: Power ON with power supply
61	S14	O	FL segment output
62	S13	O	FL segment output
63	S12	O	FL segment output
64	S11	O	FL segment output
65	S10	O	FL segment output
66	S9	O	FL segment output
67	S8	O	FL segment output
68	S7	O	FL segment output
69	S6	O	FL segment output
70	S5	O	FL segment output
71	-30V	-	FL drive power supply
72	S4	O	FL segment output
73	S3	O	FL segment output
74	S2	O	FL segment output
75	S1	O	FL segment output
76	S0	O	FL segment output
77	T10	O	FL grid output
78	T9	O	FL grid output
79	T8	O	FL grid output
80	T7	O	FL grid output

(*1) For communication mode: O, For normal mode: I

7. GENERAL INFORMATION

7.1 DISASSEMBLY/ASSEMBLY

(1) DISC TRAY

- Disassembly : ① → ② → ③ → ④ → ⑤
- Assembly : ⑤ → ①

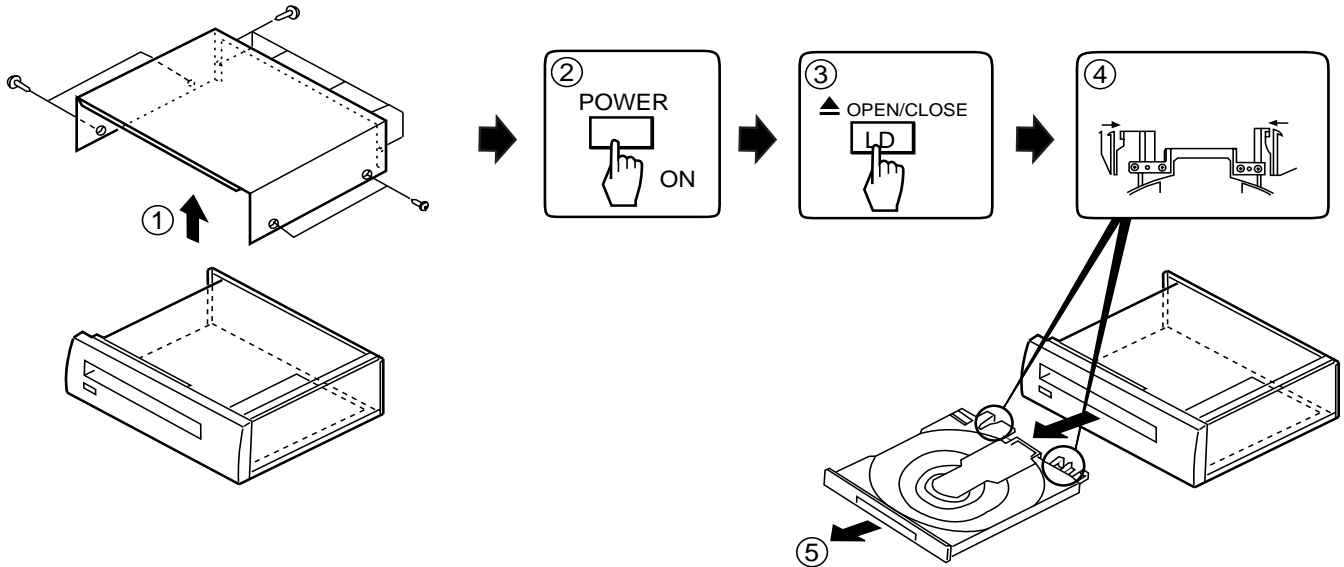

(2) DVDM ASSY

- Disassembly : ① → ② → ③ → ④
- Assembly : ④ → ③ → ② → ①

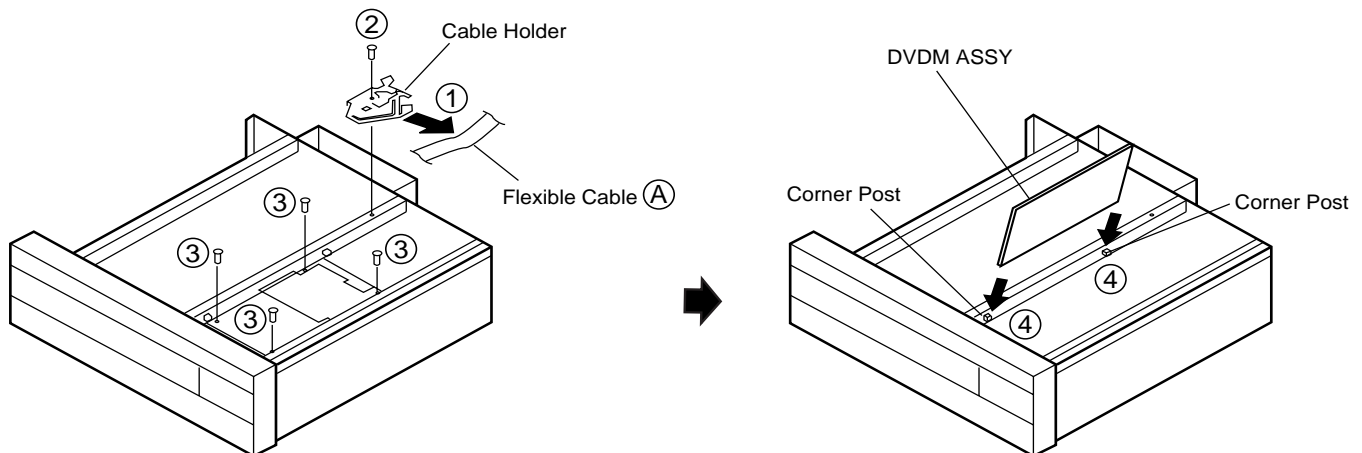

(3) CLDM ASSY

- Disassembly : ① → ② → ③ → ④ → ⑤ → ⑥ → ⑦ → ⑧
- Assembly : ⑧ → ⑦ → ⑥ → ⑤ → ④ → ③ → ② → ①

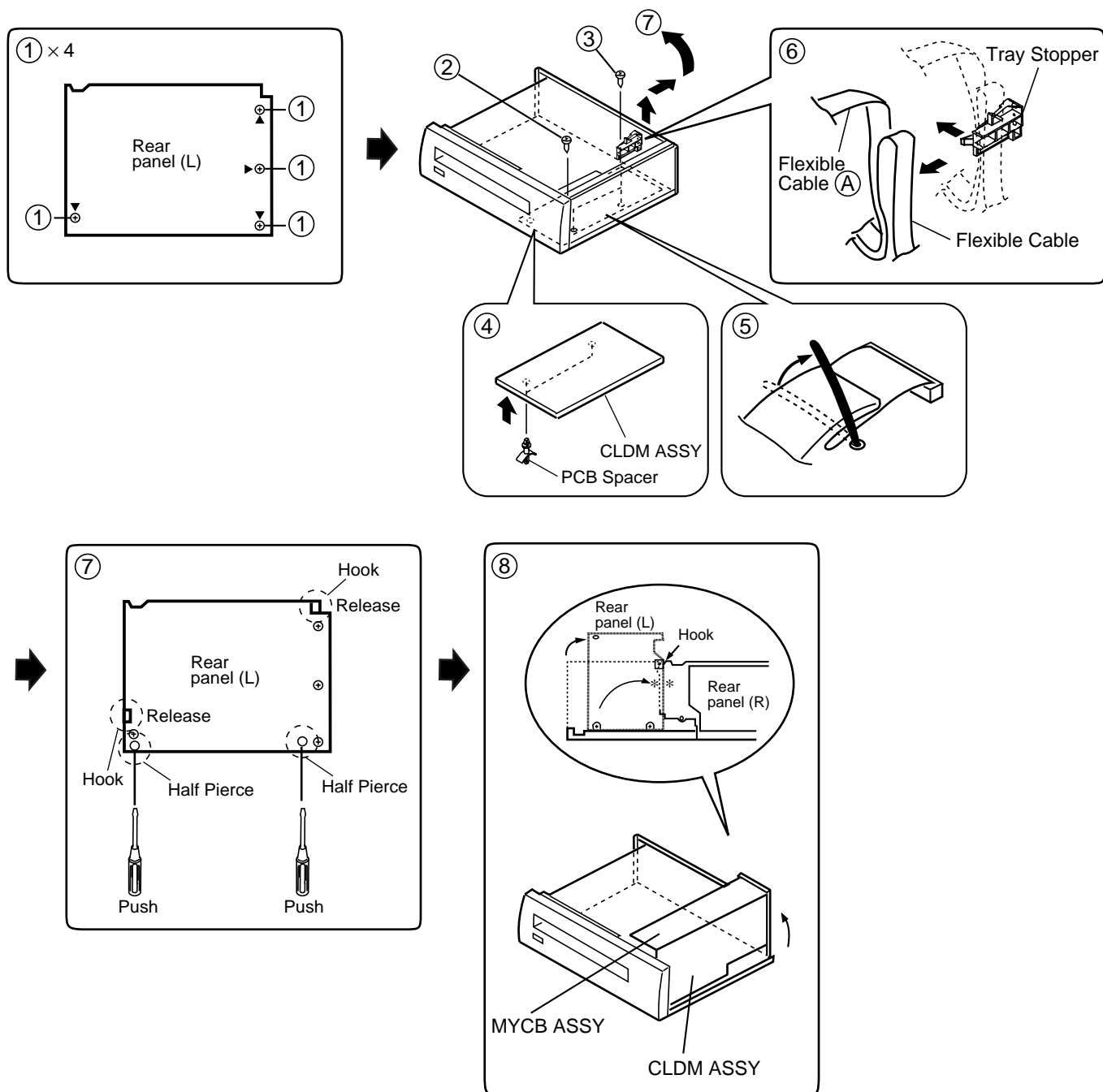

7.3 BLOCK DIAGRAM

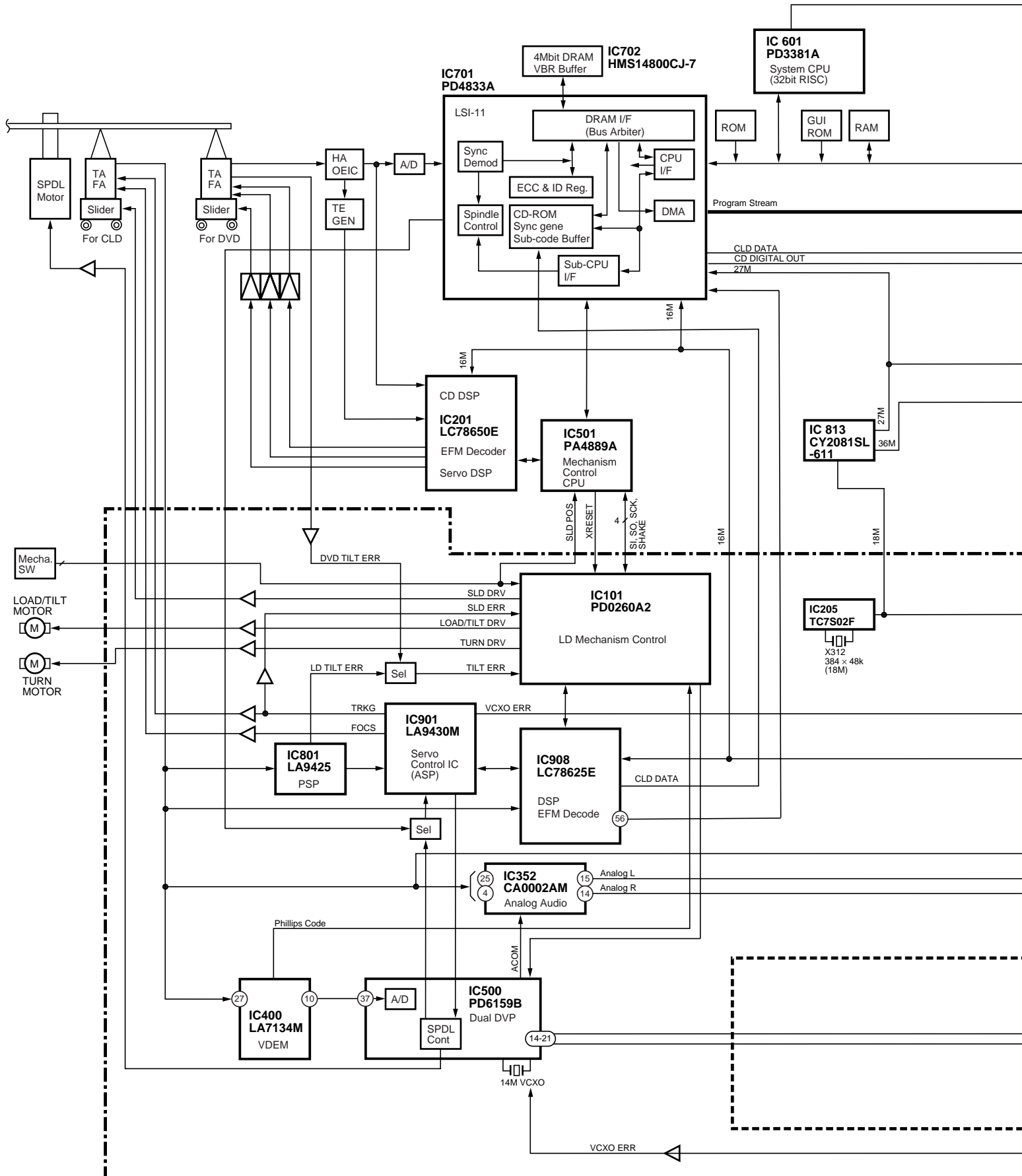

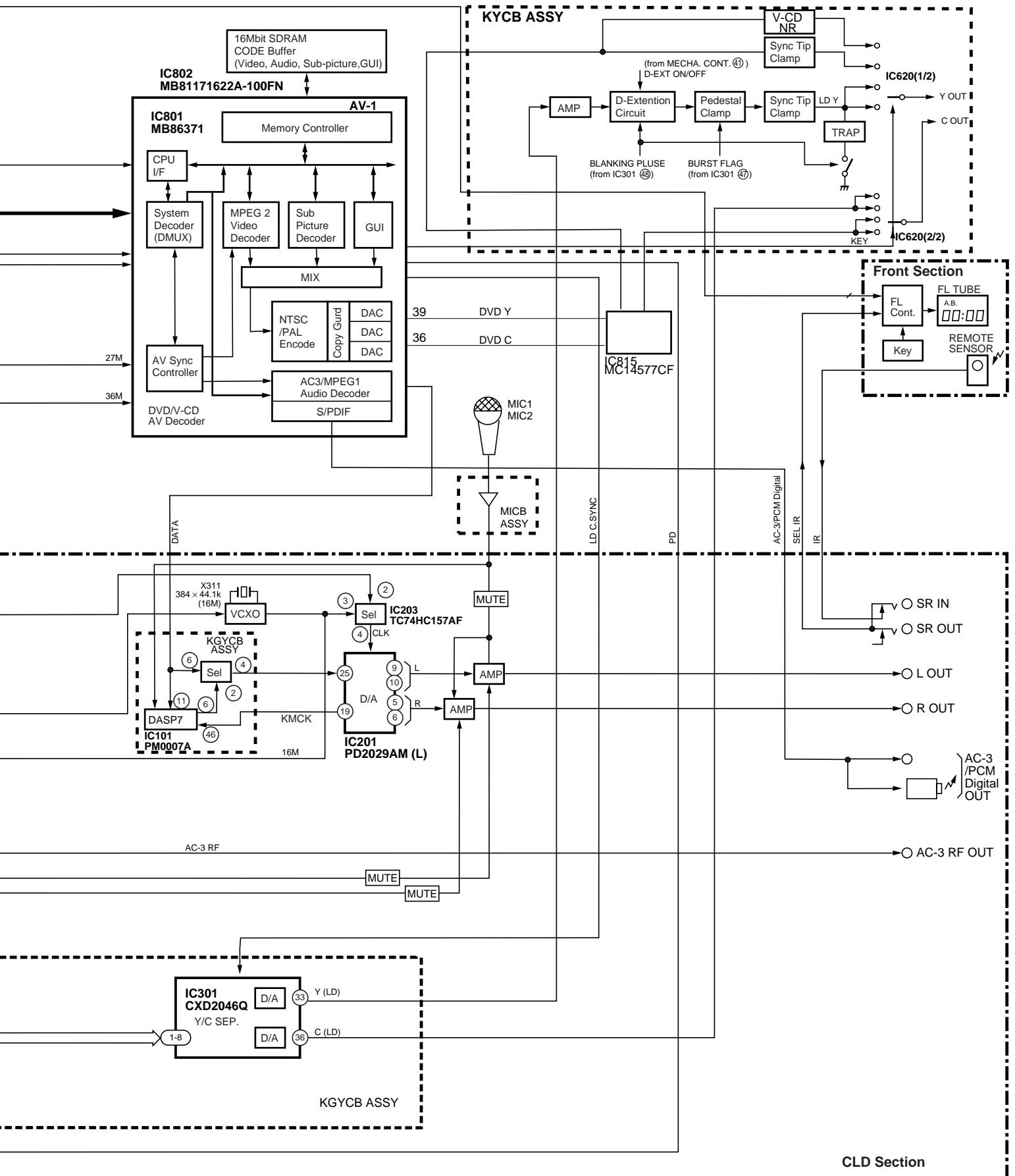

CLD Section

8. PANEL FACILITIES AND SPECIFICATIONS

■ FRONT PANEL

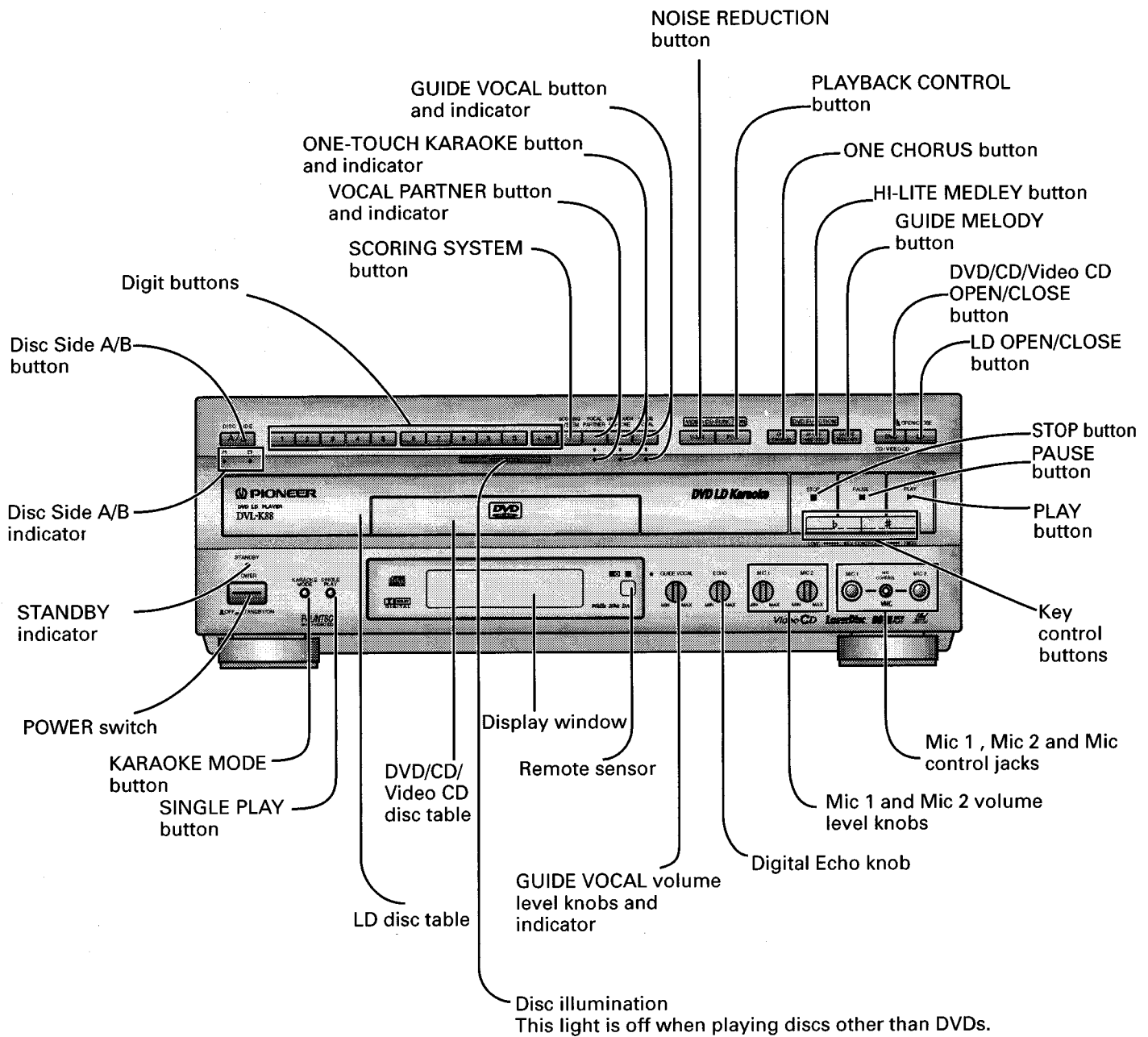

■ DISPLAY WINDOW

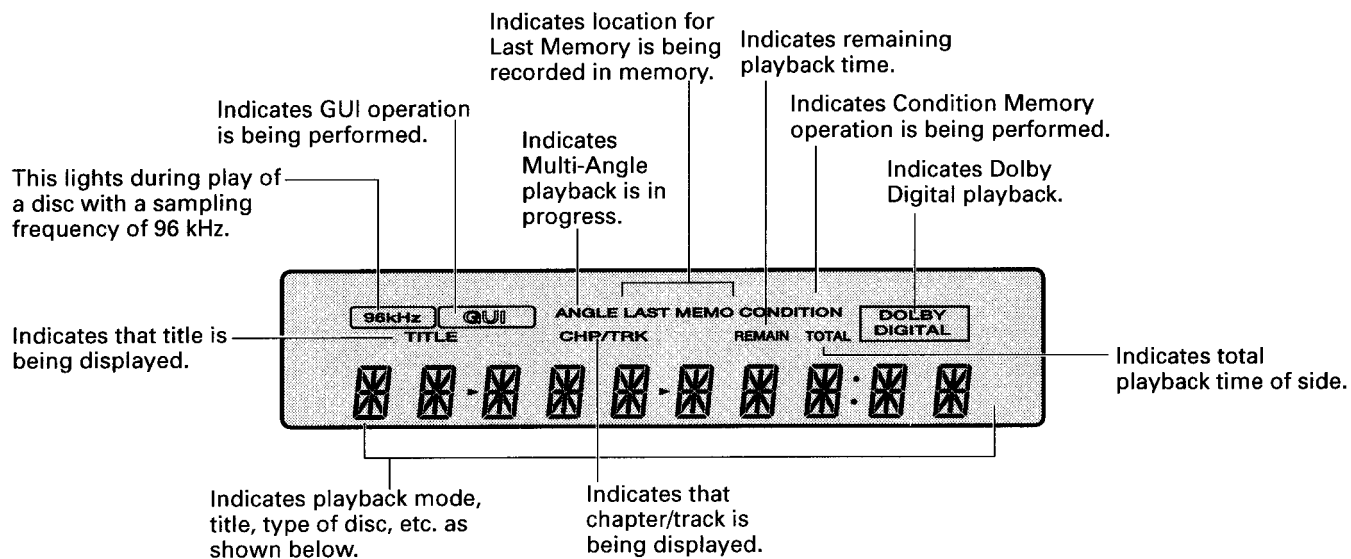

L D	:Laser Disc	PLAY	:Playback
C D	:Compact disc	STOP	:Stop
C D V	:CD video	PAUSE	:Pause
D V D	:DVD	NO DISC	:No disc
V C D	:Video CD	-- OFF --	:Power is turned off (Only when you switched POWER off using the remote control)
OPEN	:Disc table is opening or is open	MENU	:Menu mode
CLOSE	:Disc table is closing	TITLE	:Title menu
PGM	:Program playback	CHAPTER	:Chapter menu
R - TRK	:Repeat playback of the track	SUB - TITLE	:Subtitle menu
R - A	:Start point of 2 point repeat playback	SETUP	:Set-up menu
R - A D	:2 point repeat playback	AUDIO	:Audio menu
R - TTL	:Repeat playback of the title	ANGLE	:Angle menu
R - CHP	:Repeat playback of the chapter	AUX	:AUX function
R - SID	:Both sides of LD repeat playback	COND - MEM	:Condition Memory
STEREO	:Stereo	LAST - MEM	:Last Memory
PBC PLAY	:During Video CD PBC play		

■ REMOTE CONTROL

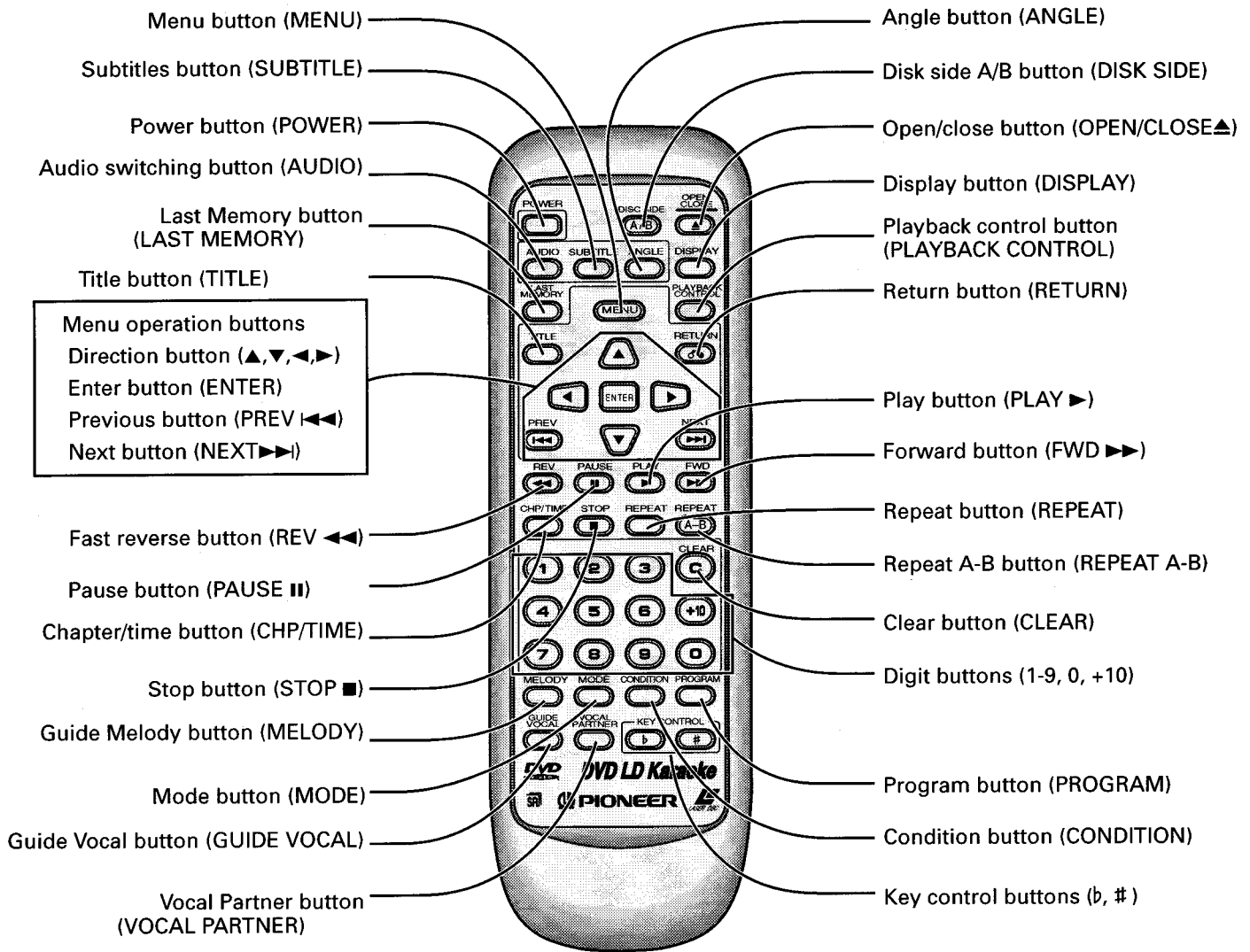

■ SPECIFICATIONS

General

System DVD system, LaserVision Disc system and Compact Disc digital audio system
 Laser Semiconductor laser: wavelength 650 nm, 780 nm
 Power requirements: 110 – 127V / 220 – 240V, 50 / 60Hz
 Power consumption 57 W
 Weight 8.7 kg
 Dimensions 420 (W) x 466 (D) x 146 (H) mm
 (Not including protruding cables, etc.)
 Operating temperature +5°C to +35°C
 Operating humidity 5% to 85% (no condensation)

S2-Video Output level

Y (luminance) - Output level 1 Vp-p (75 Ω)
 C (color) - Output level 286 mVp-p (75 Ω)
 Jacks S-VIDEO jacks

Video Output (2 pairs)

Output level 1 Vp-p (75Ω when loaded, synchronous negative)
 Jacks RCA jacks

Audio Output (2 pairs)

Output level
 During analog audio output 200 mVrms (1 kHz, 40%)
 During digital audio output 200 mVrms (1 kHz, -20 dB)
 Number of channels 2
 Jacks RCA jacks

Digital audio characteristics

Frequency response	4 Hz to 22 kHz (DVD fs: 48 kHz) 4 Hz to 20 kHz (LD, CD)
S/N ratio	115 dB (EIAJ)
Dynamic range	97 dB (EIAJ)
Wow and flutter	Limit of measurement (±0.001% W. PEAK) or lower (EIAJ)

Other Terminals

Optical digital output (PCM/□□(optical)) Optical digital jack
 Coaxial digital output (PCM/□□) RCA jack
 AC-3 RF output (for LD) RCA jack
 CONTROL IN Minijack (3.5ø)
 CONTROL OUT Minijack (3.5ø)
 AUX Input RCA jack

Accessories

Remote control unit 1
 AA/R6P dry cell batteries 2
 Audio cord 1
 Video cord 1
 Power cord 1
 Operating Instructions 1

NOTE:

The specifications and design of this product are subject to change without notice, due to improvement.

"Dolby, Digital (AC-3)" and the double-D symbol are trademarks of Dolby Laboratories Licensing Corporation.

■ ACCESSORIES

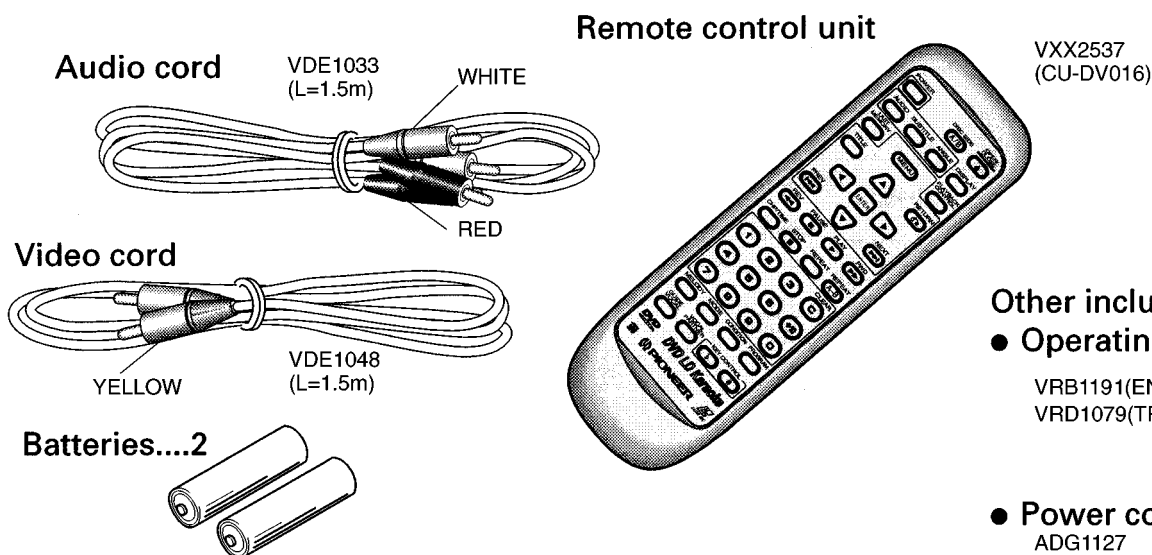

Other included items

● Operating Instructions

VRB1191(ENGLISH)
 VRD1079(TRAD-CHINESE)

● Power cord

ADG1127

Service Manual

SERVICE GUIDE

ORDER NO.
RRV1896

DVD PLAYER

DV-505

DV-S9

DVD LD PLAYER

DVL-909

CONTENTS

1. CIRCUIT DESCRIPTION	2
2. CIRCUIT DESCRIPTIONS	
FOR DV-S9 AND DV-09	10
3. TEST MODE	13
4. IC INFORMATION	22
5. FL INFORMATION	47

1. CIRCUIT DESCRIPTION

1.1 OVERALL BLOCK DIAGRAM

■ DV-505

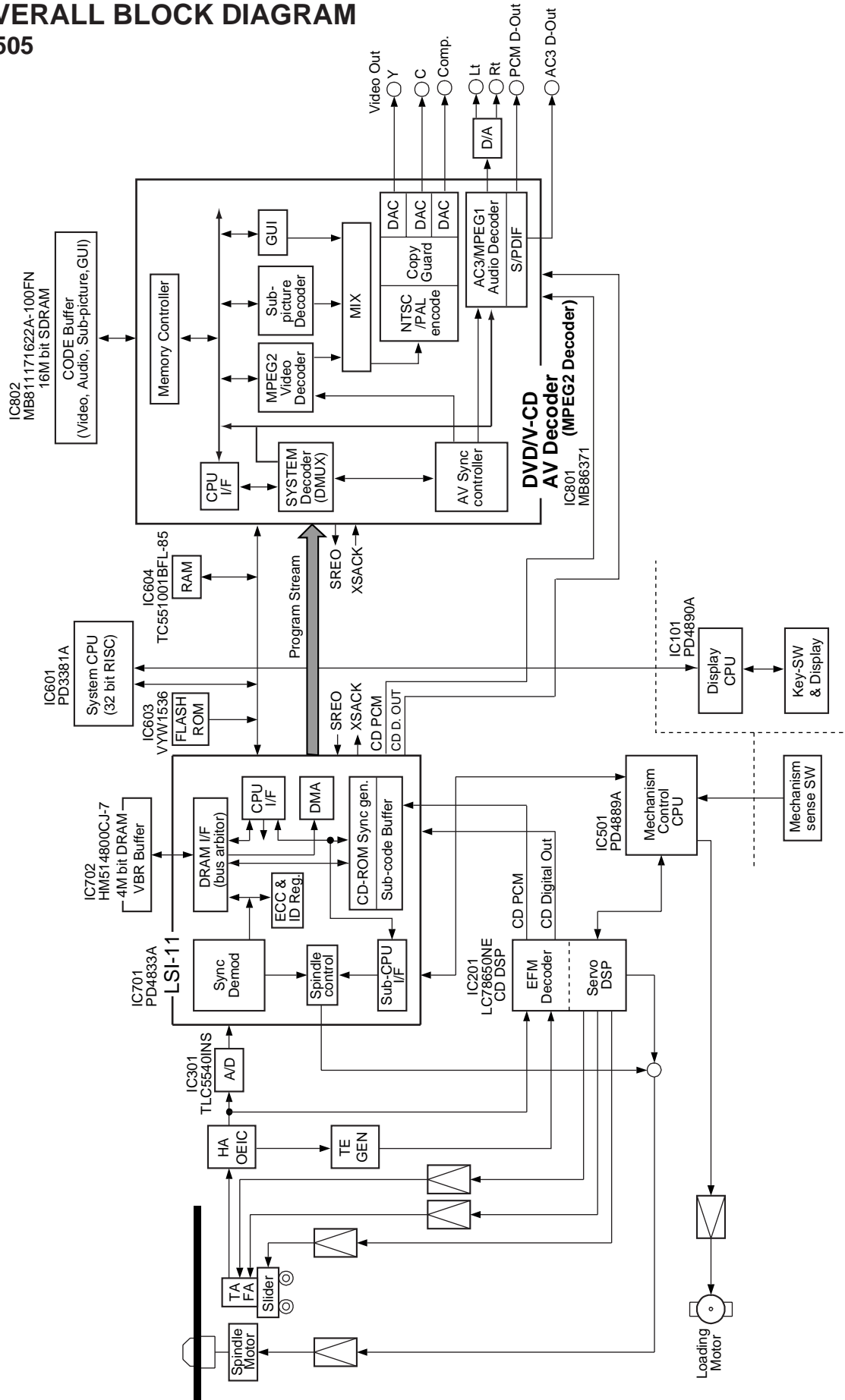

DV-S9 and DV-09

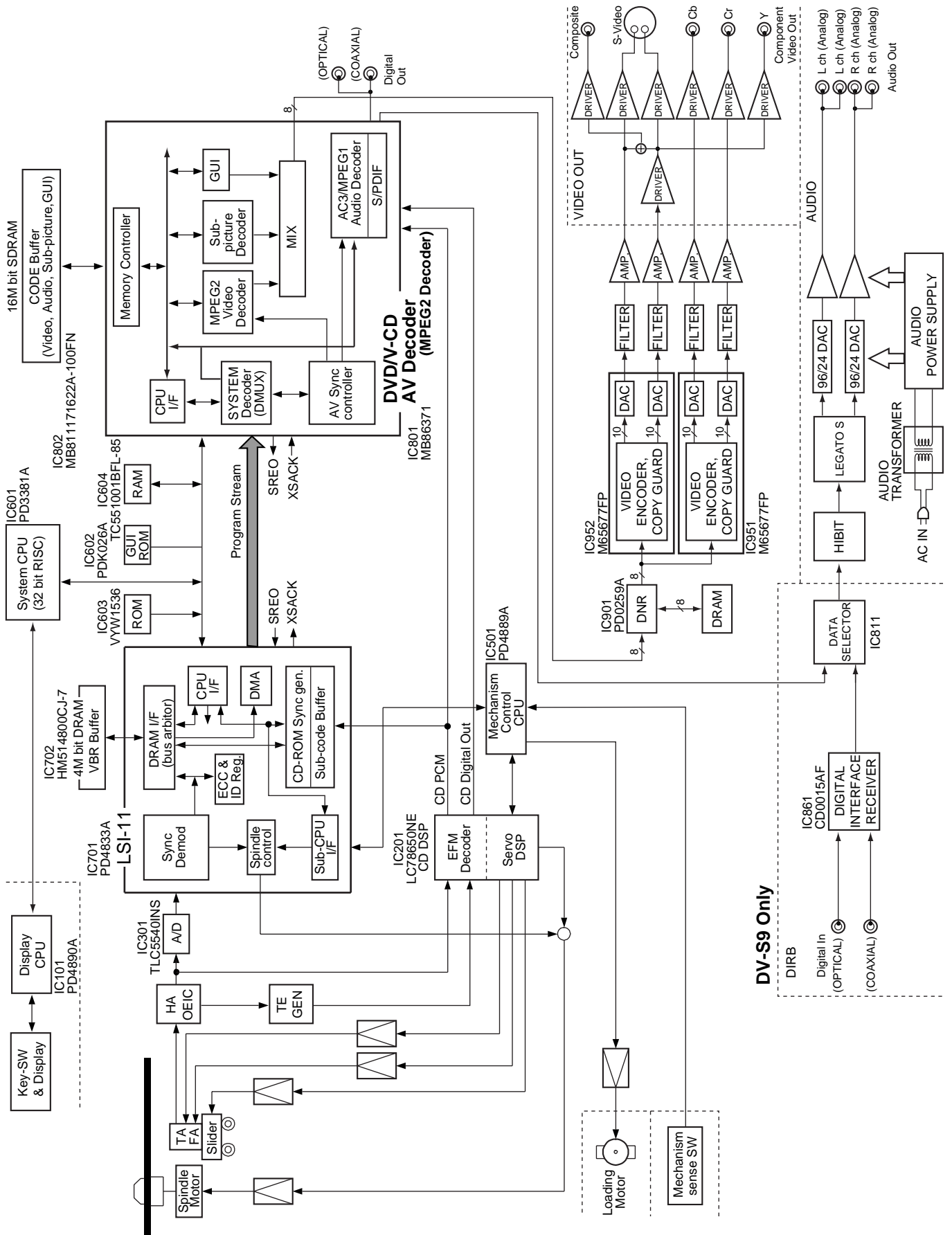

DVL-909

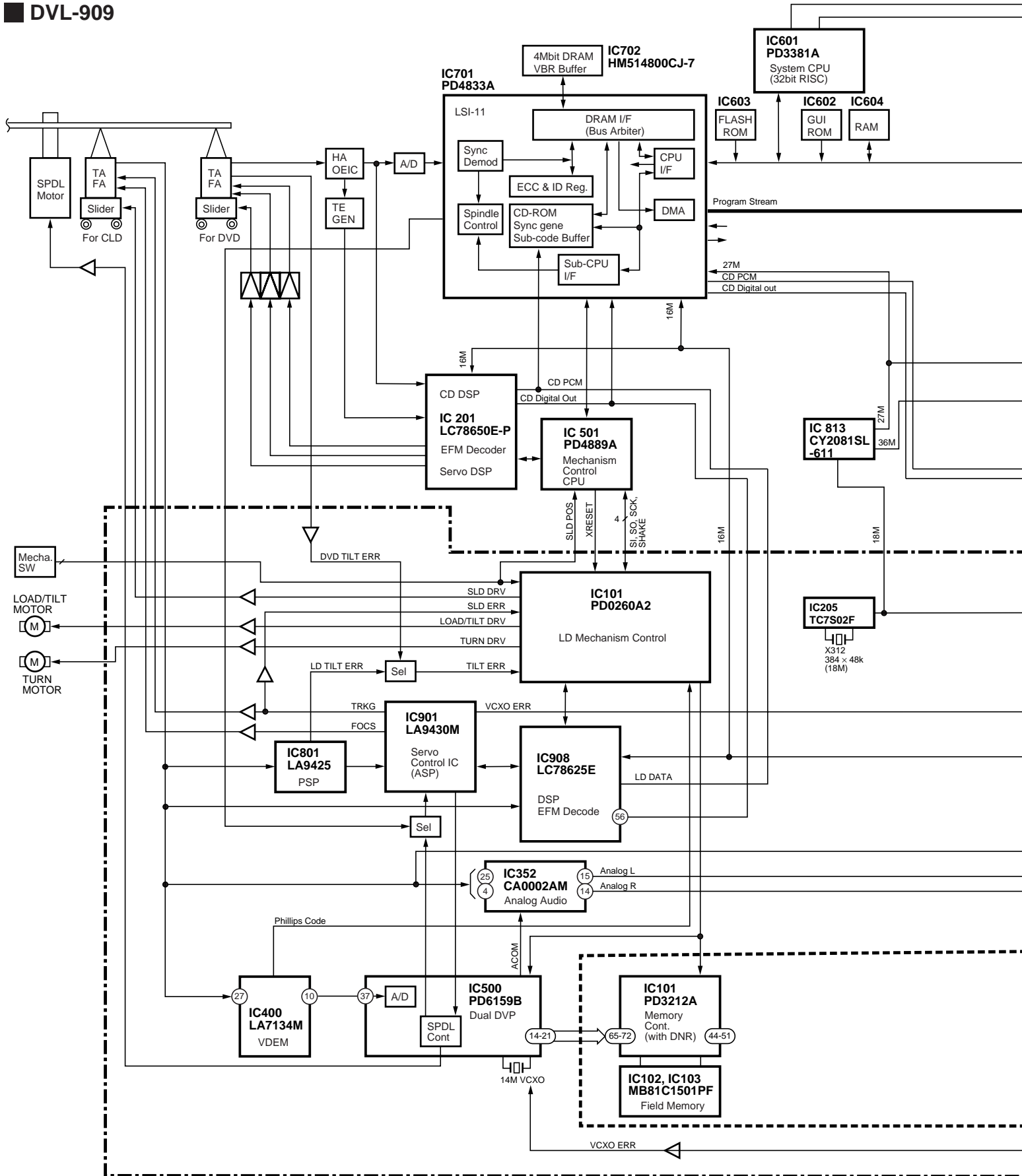

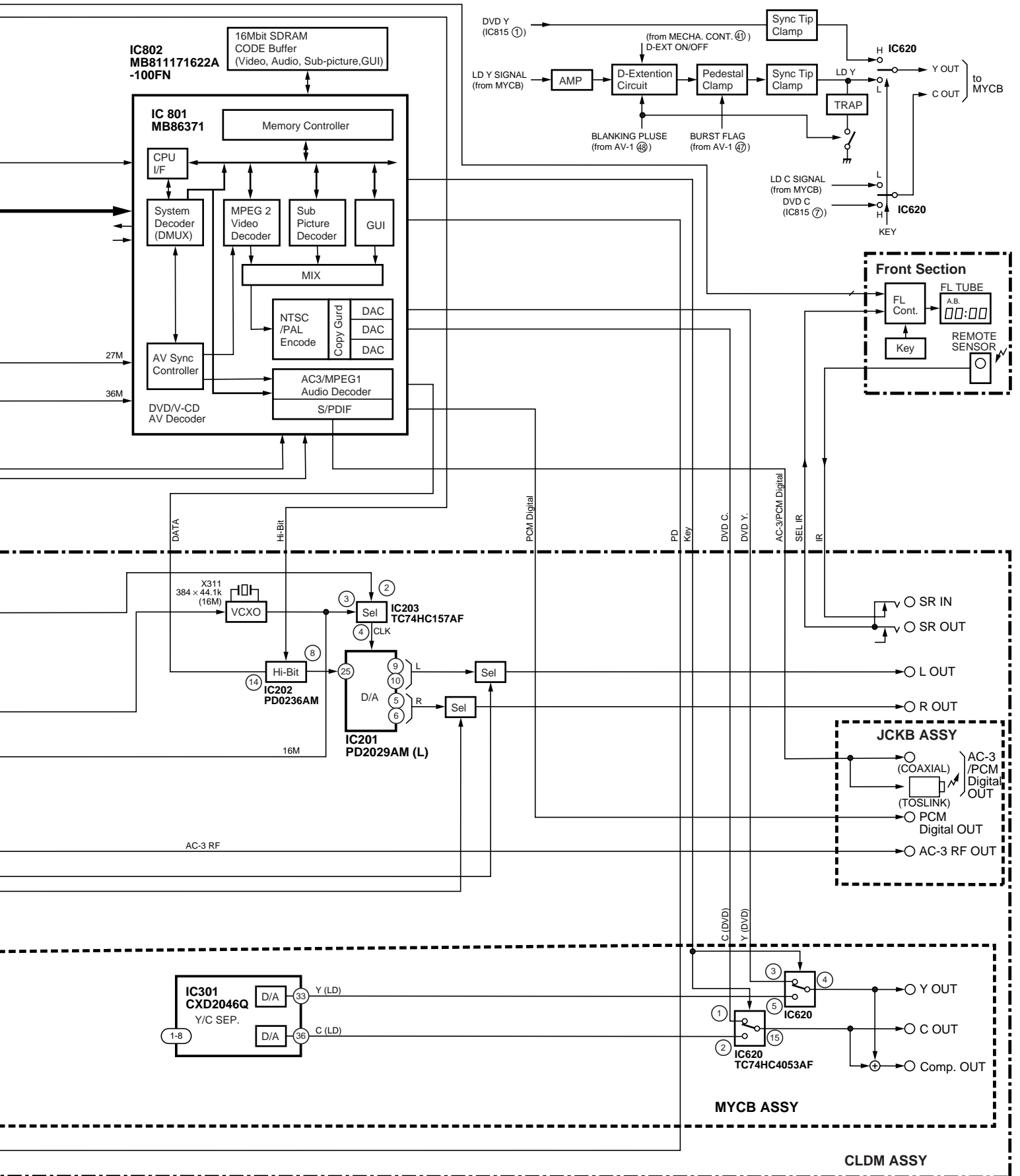

1.2 EXPLANATION OF EACH MOVEMENT

1.2.1 Sequence Up to Playback

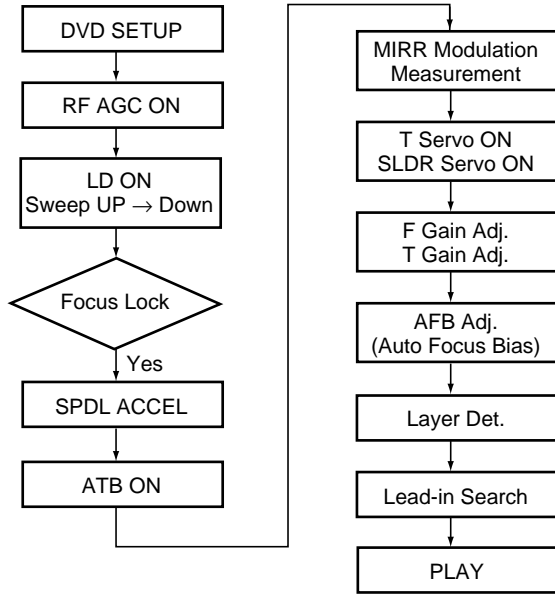

1.2.2 Focus Servo

FE generated in the RF IC is sent to the Digital servo IC.

For a DVD, the servo is turned on during the transition from “Up” to “Down” of the first-order sine wave. For a CD, it turns on during the transition from “Down” to “Up” of the first-order sine wave.

When the servo is turned on, the level of PH (the envelope of the bright side of RF) increases, and DRF becomes H. The kick-brake pulses, such as those for FOCUS jump, are also output from pin 49 of IC201.

• FOCUS SERVO

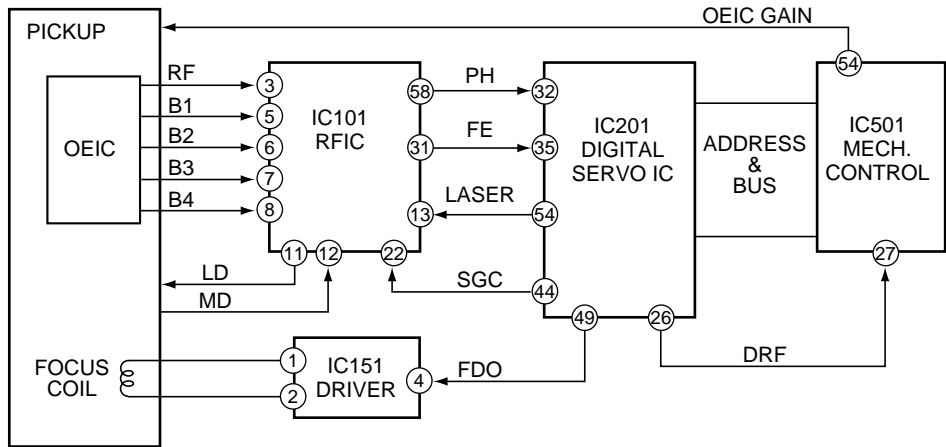

• FOCUS LOCK TIMING

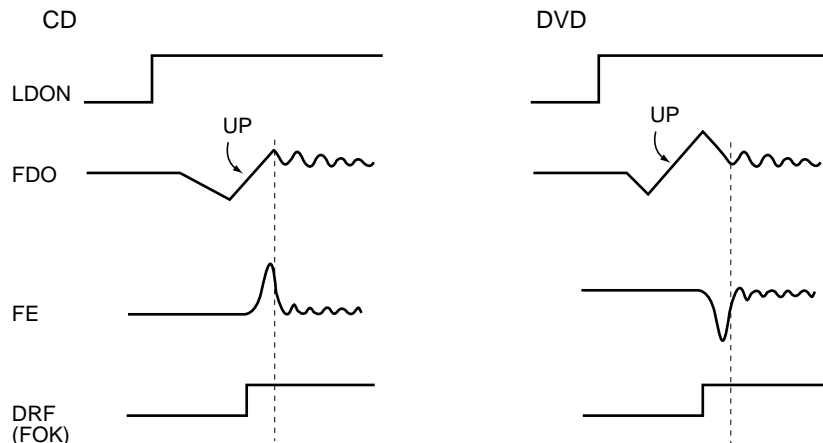

1.2.3 Tracking / Slider Servo

ATB: The tracking balance compensation is achieved by outputting the offset from the TBAL output at pin 46 of the digital servo IC, and by biasing the charge pump resistor for phase-difference error of RFIC.
 The difference is detected by processing TE at pin 34 of IC 201 with an internal digital equalizer.

TDO: In addition to the servo output, the low-band components, such as the kick-brake for jump, are added for TDO output.

SLDO: The low-band components of TE are processed by the internal digital equalizer, and deadband is added for SLDO output. The offset voltage for pickup movement is also included in the SLDO output.

• TRACKING / SLIDER SERVO

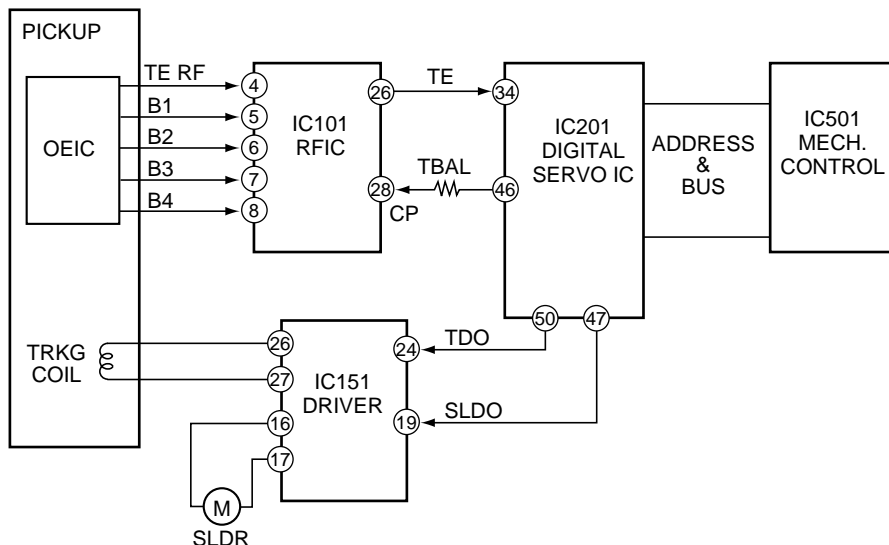

1.2.4 SPINDLE SERVO

• SPDL SERVO

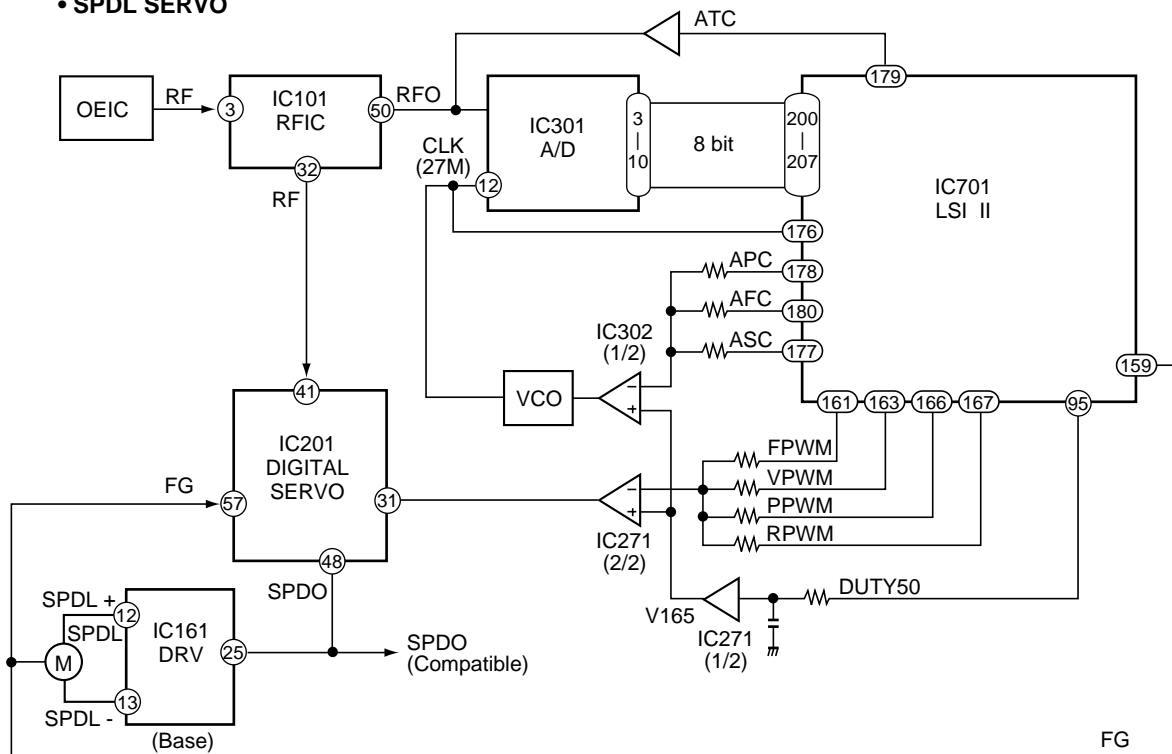

For a CD, the RF signal output from pin 32 of the RF IC is converted to binary in IC201. By comparing the binary value with the reference CLK (clock), the SPDL ERR signal is output from pin 48.

For a DVD, the SPDL ERR signal is generated from the PWM signal output from LSI-II. Upon receiving this signal via pin 31, IC201 also outputs it from pin 48, switching from the CD SPDL ERR signal.

1.2.5 Disc Determination

Determination is achieved by checking the sine wave by sweeping the lens with the OE IC gain at L and the FSC error amplifier (SGC) at the default setting. If no sine wave is detected, checking is retried after switching the OE IC gain to H and increasing the gain of the FSC error amplifier (SGC). If no sine wave is detected again, it is regarded as the NO DISC condition.

If one half of the sine wave detected at the first lens sweep is of a value less than 0.5 V, the OE IC gain is set to H and the peak-to-peak value of the sine wave is roughly adjusted to 1.8 Vp-p. By sweeping the lens around the height where the sine wave has been detected, disc determination is performed, and the sine wave is finely adjusted to 1.8 Vp-p.

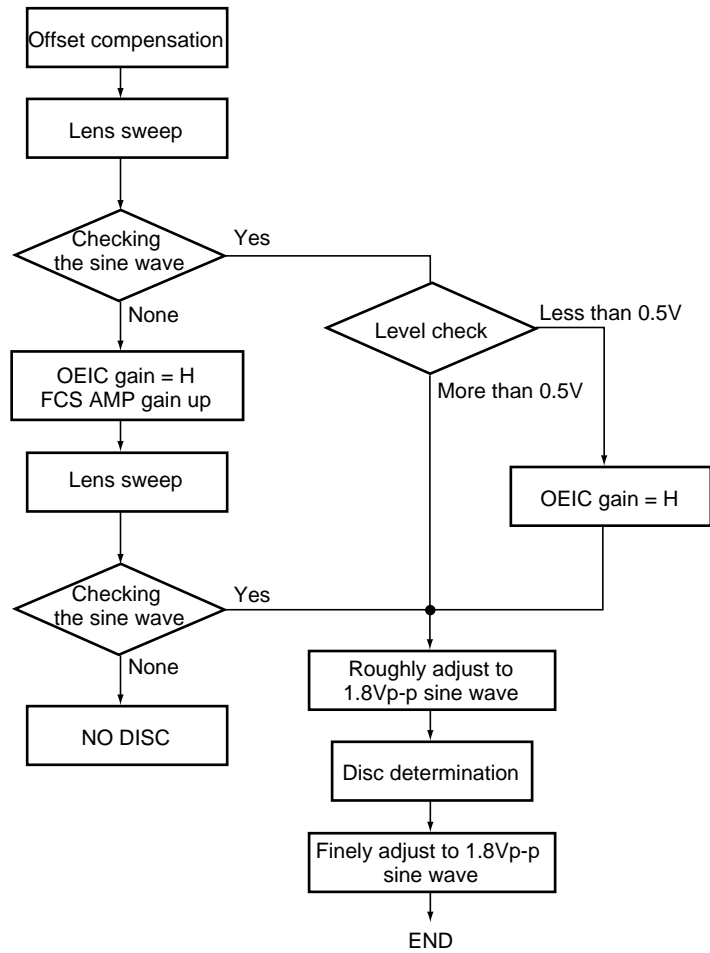

1.2.6 System Control (DVL-909)

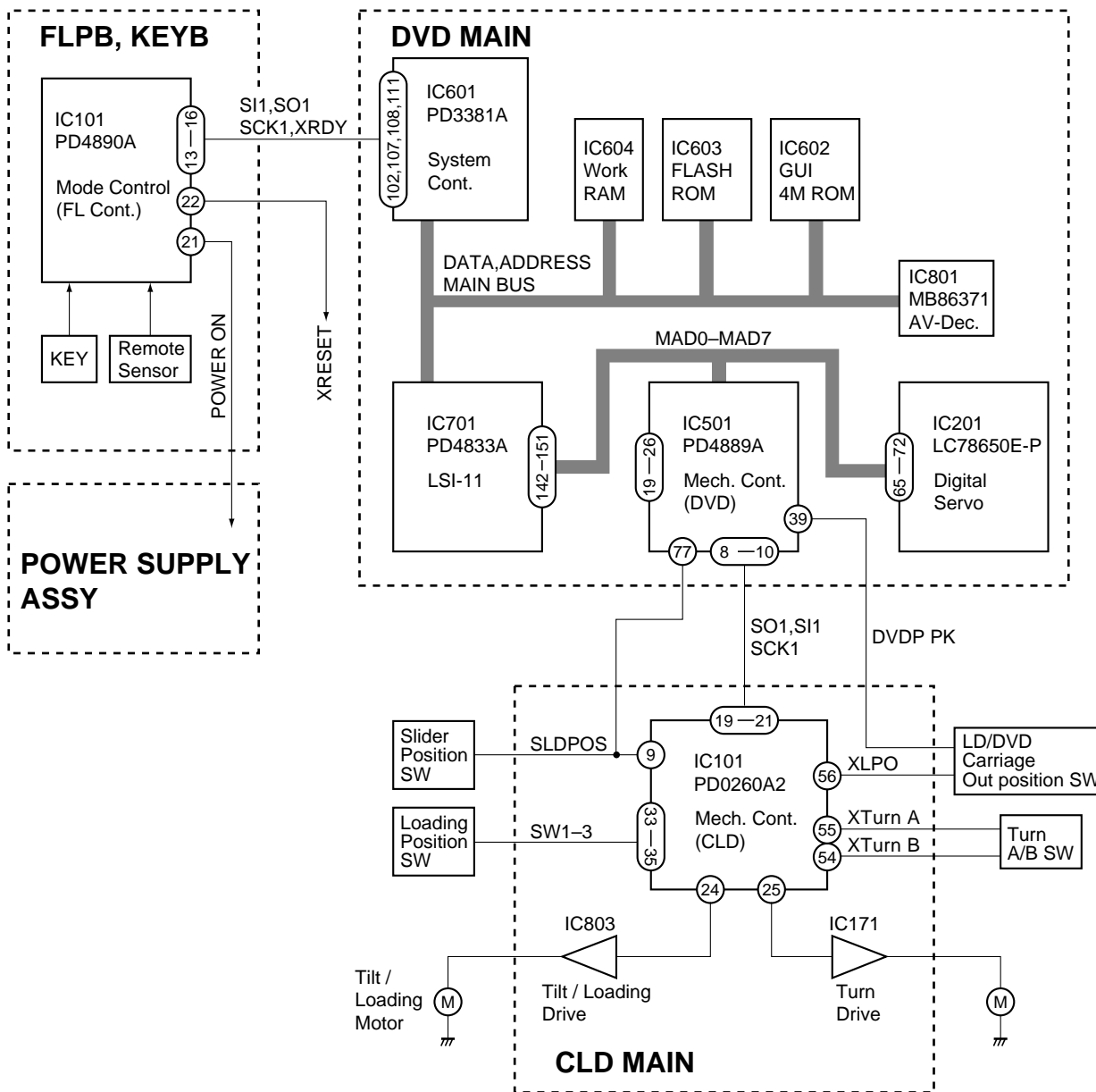

1) Interface between Mode Cont. and System Cont.

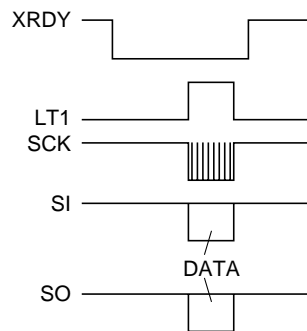
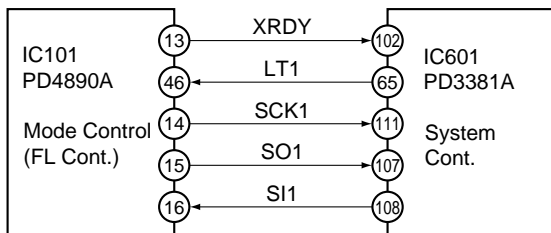

Timing Chart

If there is no communication for 2 sec., Mode Cont. turn off the power and reset.

2. CIRCUIT DESCRIPTIONS FOR DV-S9 AND DV-09

2.1 VIDEO SIGNAL PROCESSING BLOCK

2.1.1 PD0259A Block

The major purposes of the PD0259A block are;

- (1) Frame-correlative cyclic digital noise reduction
- (2) Horizontal and vertical contour compensation
- (3) Y/C timing adjustment
- (4) Frame freezing

(1) Frame-Correlative Cyclic Digital Noise Reduction

For eight-bit digital video data input to the PD0259A, noise reduction is performed through subtraction between the data and those of the corresponding points 1 frame before, delayed for the subtraction via a 4-bit DRAM by 1 frame.

The noise signal detected as a result is sent to a non-linear circuit. If the difference is larger than a specific value, it is regarded as “a change in picture,” and no canceling calculation is made.

This function is the same as that which has been performed in conventional laser-disc players. The only difference is that the input video signal here is a DVD digital component signal (4:2:2), while it is an LD digital composite signal in conventional laser-disc players.

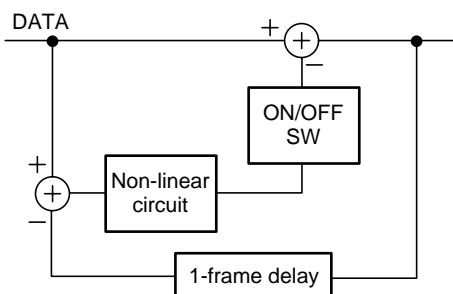

(2) Horizontal and Vertical Contour Compensations

For data after digital noise reduction, horizontal and vertical contour compensations are made only for the Y-signal.

Horizontal compensation is performed by detecting edge components from the information of the reference picture elements and those that horizontally proceed and succeed by several pixels, and then generating edge-emphasizing components through non-linear processing of the detected components.

Vertical compensation is performed by detecting edge components from information on the reference picture elements and those which vertically proceed and succeed by one line, and then generating edge-emphasizing components through non-linear processing of the detected components.

These edge-emphasizing components are added to the main-line digital data to achieve contour compensations.

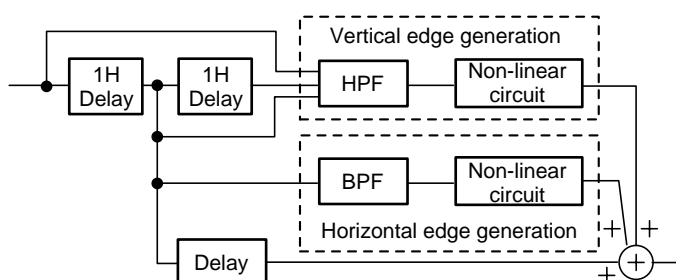

(3) Y/C-timing Adjustment

This function changes the output phase of the Y signal with respect to the Cb and Cr signals in units of the 13.5-MHz clock cycle (approx. 74 ns).

(4) Frame Freezing

In response to a command sent from the system control computer by serial transmission, data for one frame are frozen, and the frozen picture is output.

This function is specific to the DV-S9 and is used only for picture-by-picture reversing by jog/shuttle operation or “Slow 1” playback operation.

2.1.2 M65677FP Block

The M65677FP block functions as an NTSC encoder that converts digital component signals to analog Y, C, Cb and Cr signals. While our popular models other than the DV-S9 use the built-in encoder in the MB86371 block, an external NTSC encoder is added to the DV-S9, as it performs digital processing in the PD0259A block.

In addition to NTSC encoding, the M65677FP also performs:

- (1) D.EXT(DV-S9)/BLACK LVL(DV-09)
- (2) C.LEVEL adjustment

(1) D.EXT(DV-S9)/BLACK LVL(DV-09)

Setup of -7.5 IRE is added to the Y signal. D.EXT(DV-S9)/BLACK LVL(DV-09) processing using analog signals in conventional laser disc players is achieved by using digital signals.

(2) C.LEVEL Adjustments

The burst level of the C signal can be varied centering around 40 IRE.

Therefore, it is performed for the S-connector and CVBS-connector outputs, but not for the color-difference output.

This function is also not available if the connected TV receiver has no AGC circuit.

2.1.3 Analog Video Signal Processing Block

The video signals output from the built-in 10-bit DA converter of the M65677FP pass through a low-pass filter and amplifier, and are output from the DVD MAIN Assy and sent to the VOUT Assy.

In the VOUT Assy, analog noise-reduction processing having three levels (OFF, low, and high) is initially applied only to the Y signal. This analog noise reduction is the same as that performed by conventional laser-disc players. The register port output in serial communication that the PD0259A receives from the system-control computer is used as the control signal for analog noise reduction.

After analog noise reduction, a CVBS signal is generated by composing the Y and C signals (no clamping is performed for the C signal). The timing pulse BF to be used for pedestal clamping is supplied from the PD0259A. This signal is adjusted within the PD0259A so that it provides the timing for the burst portions of the output video signals.

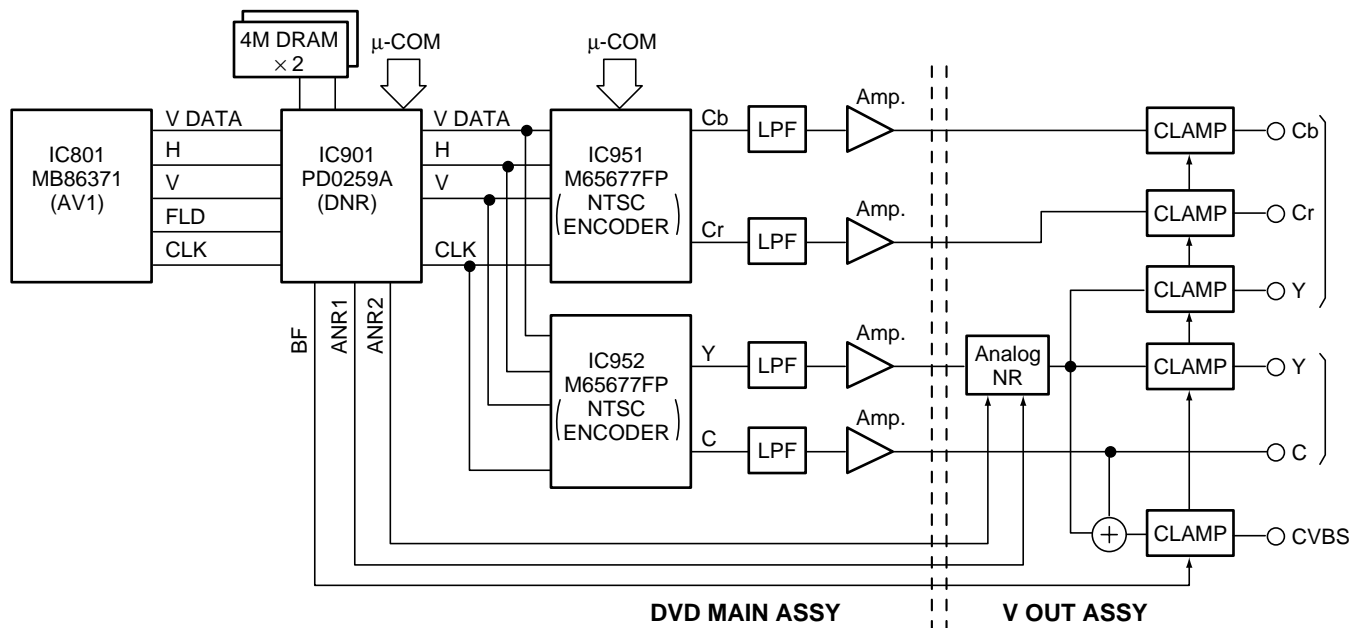

2.2 DIRB BLOCK (DIRB ASSY) (DV-S9 ONLY)

The two major purposes of the DIRB block are the following:

- (1) Switching between data reproduced from a disc and a data signal in DAC mode
- (2) Data decoding in external input mode (DAC mode)

(1) Switching Between Data Reproduced from a Disc and a Data Signal in DAC Mode

The signal switching is performed at IC811, sending 3-line data (LRCK, BCK and DATA) to the AUDIO Assy. The switching control line (DAC MODE) is supplied from the DVD MAIN Assy. The master clock (MCK) is generated by a crystal on the AUDIO Assy when reproducing a disc, and by IC861 in DAC mode. MCK is sent to the AUDIO Assy via RXP.

(2) Data Decoding in External Input Mode (DAC Mode)

When the user selects DAC mode, the DAC MODE port is set to H and VCO in IC861 starts oscillating. (VCO does not oscillate in any other modes than DAC mode.) When there is a loss of an external input or a coaxial digital input, the digital input signal is sent to IC861 from RXP of CN801, generating 3-line data corresponding to the input sampling frequency. At the same time, the master clock (MCK) to be used in DAC mode is also generated. For a 96kHz input, the MCK frequency is divided by 2 by IC831.

When the user selects the internal clock as the system clock, the clock generated by the crystal on the AUDIO Assy is sent to the DVD MAIN Assy. When the user selects an external sync as the system clock, the following parameters are used.

FS(kHz)	16M clock in the AUDIO Assy	18M clock in the AUDIO Assy	16M clock sent to the DVD MAIN Assy	18M clock sent to the DVD MAIN Assy
32	Oscillates	Oscillates	Crystal 16M clock	Crystal 18M clock
44.1	Stops oscillating	Oscillates	DIR 16M clock	Crystal 18M clock
48	Oscillates	Stops oscillating	Crystal 16M clock	DIR 18M clock
96	Oscillates	Stops oscillating	Crystal 16M clock	DIR 18M clock

If there is no external input or locking onto the input digital signal cannot be achieved, the ERR signal at pin 43 of IC861 is set to H, and the crystal in the AUDIO Assy immediately starts oscillating. In such cases, the clock sent to the DVD MAIN Assy will always be a crystal clock.

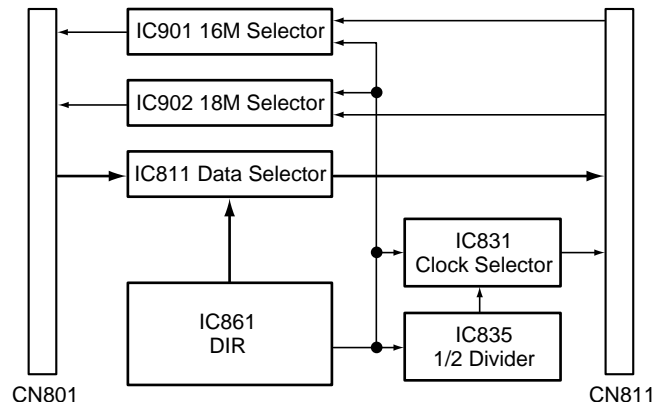

2.3 96K, 24-Bit, HIBIT LEGATO S SYSTEM (AUDIO ASSY)

All 16-bit and 20-bit sources are converted to 24-bit data by IC101, which lets a 24-bit data pass through.

As PCM1702P is a 20-bit D/A converter, processing of the upper 20 bits is assigned to it by the shift register.

The lower 4 bits are converted from serial to parallel, then the significance of each bit is converted digital to analog, functioning as a 4-bit D/A converter for the lower 4 bits.

By adding the lower 4 bits to the upper 20 bits in the low-pass & ADD block, D/A conversion is achieved for 24 bits.

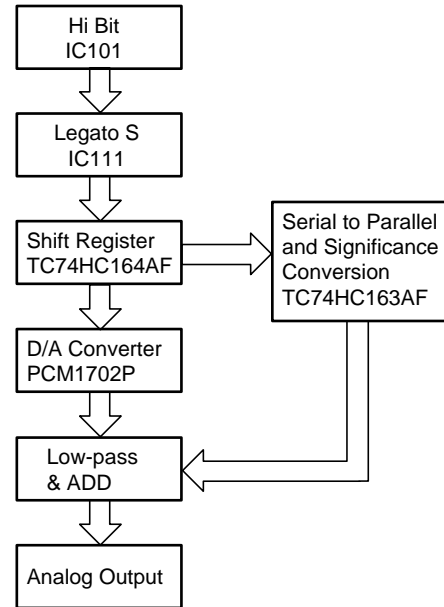

3. TEST MODE

3.1 HOW TO ENTER THE TEST MODE

There is the three following methods in an enters of the test mode.

1. Short-circuit the terminals (TP6006 and TP6007) for test mode entry at the side of the system control IC (IC601) of DVDM ASSY, and turn the power on.
2. Input [ESC] key and [TEST/RANDOM] key of the test mode remote control unit in order under the power on condition.
3. Connect a personal computer with the RS232C terminal (CN106), and input entry command (TE) of test mode from the personal computer.

Note: FL indication and LED come all to light until key operation is done when entering the test mode.

3.2 RELEASE THE TEST MODE

There is the three following methods in a release of the test mode.

1. Turn the power off.
2. Press [ESC] key of the remote control unit. At this time, reset it for a while except for during the LD and CDV set.
3. Connect a personal computer with the RS232C terminal (CN106), and input normal mode entry command (NE) from the personal computer.

3.3 THE EXPLANATION OF EACH FUNCTION

The function that can be operated in the test mode is as the following. Use a LD remote control unit in the test mode.

(1) Door Open/Close

1. Press [REPEAT A-B] (48) key of the remote control unit.
2. Press [OPEN/CLOSE] key of the player from the stop condition.

(2) Stop

1. Press [REPEAT] (44) key of the remote control unit.
2. Press [STOP] key of the remote control unit or the player from the stop condition.

(3) Play 1 (Demultiplex exist which it tries to output the playback screen)

1. Press [PLAY] (17) key of the remote control unit.
 - CLD rise up at the tracking open condition. However, it becomes tracking close when entering the test mode during the play.
 - DVD rise up at the tracking close. Playback screen may not appear because the NAVI information isn't read in the test mode.

(4) Play 2 (Demultiplex is absent which performing trace only)

1. Press [TV/LDP] (0F) key of the remote control unit.
 - It is equal to the play 1 with CLD.
 - Perform only tracing with DVD, and there are no video and audio output.

(5) Pause

1. It becomes pause condition by pressing [CX] (0E) key of the remote control unit in the play.
2. Pause ON/OFF changes alternately by pressing [PAUSE] (18) key in the play.

(6) Search Address Input Entry

It becomes the address input mode when [+10] key (1F) is pressed. (indication for the most significant digit : >)

Indicate the last address as the initial condition in this time.

Only in case of DVD, addition search (indication for the most significant digit : +) and subtraction search (indication for the most significant digit : -) are able to select in order by pressing [+10] key continuously.

The address where input value was added to the present address is make to search with addition search.

The address where input value was subtracted to the present address is make to search with subtraction search.

In case of CD is only absolute time search.

Also address clear and release from the address input mode are able to perform by 2 steps by pressing [CLEAR] (45) key.

(7) Search Address Input

Press [0] to [9] keys of the remote control unit.

Set up the address by the hexadecimal number with DVD.

When [PROGRAM] (4C) key is pressed in the address input mode, input mode changes to hexadecimal number input (Indicates "*" mark), and [1] to [6] keys are input as [A] to [F].

At this time, [7], [8], [9] and [0] keys are not accepted.

Also the hexadecimal number input and the decimal number input can be changed with toggle.

(8) Search Practice

1. Press [CHP/TIM] (13) key of the remote control unit.
 - Practice the on screen no playback (Doesn't demultiplex) after the search with DVD.
2. Press [PLAY] (17) key of the remote control unit.
 - Practice the on screen playback (demultiplex exists) after the search with DVD.

(9) Side Change

This function becomes effective when a set disk is LD.

1. Change a side on the side A from the side B when pressing [SIDE A] (4D) key of the remote control unit.
2. Change a side on the side B from the side A when pressing [SIDE B] (4E) key of the remote control unit

(10) Tracking Open

1. Press [STEP FWD] (54) key of the remote control unit in the play condition.
2. Switch the open/close by pressing [PLAY] key of the remote control unit or the player during the play (CD only).

(11) Tracking Close

1. Press [STEP RVS] (50) key of the remote control unit in the play condition.
2. Switch the open/close by pressing [PLAY] key of the remote control unit or the player during the play (CD only).

(12) Slider In

1. Press [SCAN RVS] (11) key of the remote control unit in the tracking off condition.
2. Turn the shuttle of the remote control unit in the REV direction (2C to 2F) in the tracking off condition. (DVD only)

(13) Slider Out

1. Press [SCAN FWD] (10) key of the remote control unit in the tracking off condition.
2. Turn the shuttle of the remote control unit in the FWD direction (28 to 2A) in the tracking off condition. (DVD only)

(14) Scan In

1. Press [SCAN RVS] (11) key of the remote control unit in the tracking on condition.
2. Turn the shuttle of the remote control unit in the REV direction (2C to 2F) in the tracking on condition.
 - DVD can be scanned only in the case of the play 2 (playback without demultiplex).

(15) Scan Out

1. Press [SCAN FWD] (10) key of the remote control unit in the tracking on condition.
2. Turn the shuttle of the remote control unit in the FWD direction (28 to 2A) in the tracking on condition.
 - DVD can be scanned only in the case of the play 2 (playback without demultiplex).

(16) Loading In/Out

When pressing [SKIP REV] (53) key of the remote control unit in the open condition, it loads in the clamp direction. Then it loads in the open direction when pressing [SKIP FWD] (52) key.

- This function can practice only when it is indicated with "OPEN" in FL.

(17) Tilt Neutral

Press [SPEED DOWN] (46) key of the remote control unit.

(18) Tilt Servo On/Off

- a. On
Press [SPEED UP] (47) key of the remote control unit.
- b. Off
Press [SKIP REV] (53) key and [SKIP FWD] (52) key of the remote control unit at the tilt servo on or the tilt neutral.

(19) Tilt Down

A manual moves in the going down direction when [SKIP REV] (53) key of the remote control unit is pressed during the play at the time of tilt off.

(20) Tilt Up

A manual moves in the going up direction when [SKIP FWD] (52) key of the remote control unit is pressed during the play at the time of tilt off.

(21) Focus Jump +

Focus jumps in 1 layer from 0 layer when [MULTI FWD] (58) key of the remote control unit is pressed. (DVD only)

(22) Focus Jump -

Focus jumps in 0 layer from 1 layer when [MULTI REV] (55) key of the remote control unit is pressed. (DVD only)

(23) The First And The Second Screen Switching

Every time [DISPLAY] (43) key of the remote control unit is pressed, the contents of the version indication part (the bottom right of the screen) change. (Refer to page 17.)

(24) Screen Display On

1. Press [DISPLAY] (43) key of the remote control unit.
2. Display on/off switches every time [PROGRAM] (4C) key of the remote control unit is pressed.
 - When [DISPLAY] key is pressed in the display on, change the part number indication of the microprocessor and revision indication.
 - Initial state is screen display on and it becomes the part number indication of the microprocessor.

(25) Screen Display Off

1. Press [AUDIO] (1E) key of the remote control unit.
2. Display on/off switches every time [PROGRAM] (4C) key of the remote control unit is pressed.

(26) Background Color Switching

1. Change the background color (eight colors) prepared for in advance every time [2/R] (49) key of the remote control unit is pressed in order.
[Blue→Green→Light blue→Red→Purple→Yellow→Gray→Black→Blue ...]
2. Change the background color (eight colors) prepared for in advance every time [1/L] (4B) key of the remote control unit is pressed in order.
[Blue→Black→Gray→Yellow→Purple→Red→Light blue→Green→Blue ...]

(27) Video Output Switching

1. It becomes component output when pressing [DIGITAL EFFECT] (5C) key of the remote control unit.
2. It becomes composite output when pressing [STILL WITH SOUND] (5B) key of the remote control unit.

3.4 EXPANSION FUNCTION 1

Set the reception mode of expansion function by pressing [TEST] (5E) key of the test mode remote control unit, then expansion function is able to execute by pressing the key of [0] to [9].

Indication for the most significant digit becomes "T" during the reception mode of expansion function. (This mode can on and off with toggle.)

(1) LD On

Turn the laser diode to on by pressing [TEST] and [1] keys in order.

(2) Focus On

Focus locks by pressing [TEST] and [2] keys in order.

(3) Focus Sweep

Repeat focus sweep by pressing [TEST] and [3] keys in order.

(4) Spindle FG Servo

Rising up the spindle and FG servo becomes on by pressing [TEST] and [5] keys in order.

(5) AGC On/Off

Switch the AGC on and off with toggle by pressing [TEST] and [7] keys in order.

(6) Jitter Value Indication.

It becomes the jitter-value indication mode by pressing [TEST] and [DIG/ANA] keys in order.

(7) DSP coefficient indication of FTS system.

Set up the address (four digits) of the coefficient that it wants to see by the point of search address input, then real time indicates the coefficient in OSD by pressing [TEST] and [9] keys in order.

(8) CD Error Rate Indication

Indicate the value in OSD after measuring is completed by pressing [TEST] and [0] keys in order after set up the measuring time (1 to 8 seconds) by the point of search address input.

3.5 EXPANSION FUNCTION 2

Set the reception mode of expansion function 2 by pressing [HILITE/INTRO] (55) key of the remote control unit, then expansion function 2 is able to execute by pressing the key of [0] to [9].

(1) Forced DVD Setting

In the checker mode, set up the condition that DVD is attached forcibly except for the result of disc distinction by pressing [HILITE/INTRO] and [1] keys in order.

In the no checker mode (normal test mode), once execute the setting but abandon it soon.

Therefore, perform the disc distinction again for the safety when rising up the player in this condition.

(2) Forced CD Setting

In the checker mode, set up the condition that CD is attached forcibly except for the result of disc distinction by pressing [HILITE/INTRO] and [3] keys in order.

In the no checker mode (normal test mode), once execute the setting but abandon it soon.

Therefore, perform the disc distinction again for the safety when rising up the player in this condition.

(3) Execute The Disk Distinction

In the checker mode, execute the disc distinction result by pressing [HILITE/INTRO] and [0] keys in order.

3.6 List of Test Mode Function

Contents of Command	Condition	Key Name of Remote Control Unit	Mode of Remote Control Unit
Open	STOP	REPEAT A	A8-48
Close	OPEN	REPEAT A	A8-48
Stop	PLAY	REPEAT B	A8-44
Play (DVD is only tracing.)	STOP	TV/LDP	A8-0F
Play (DVD is with decode.)	STOP	PLAY	A8-17
Pause on	PLAY	CX	A8-0E
Pause on/off	PLAY/PAUSE	PAUSE	A8-18
Search address input (0 to 9) *Use for other numerical value input		0 to 9	A8-00 to 09

DV-505, DVL-909, DV-S9

Contents of Command	Condition	Key Name of Remote Control Unit	Mode of Remote Control Unit
Search address input (A to F)	During address input	PGM+1 to 6	
① Search address clear	During address input	CLEAR	A8-45
② Escape the search input mode	Address = 0		
Change the search address input mode (Off→absolute address→addition→subtraction→Off) *Use for other numerical value input.		+10	A8-1F
Search execution (ignore the wrong address)		CHAP/TIME	A8-13
Side change (side B→side A)	LD	SIDE A	A8-4D
Side change (side A→side B)	LD	SIDE B	A8-4E
Tracking open	PLAY	STEP FWD	A8-54
Tracking close	PLAY	STEP REV	A8-50
Slider in	TR : Off	SCAN REV Shuttle REV	A8-11 A8-2C to 2F
Low speed scan REV	TR : On	SCAN REV	A8-11
Scan REV (Jump number is variable)	TR : On	Shuttle REV	A8-2C to 2F
Slider out	TR : Off	SCAN FWD Shuttle FWD	A8-10 A8-28 to 2B
Low speed scan FWD	TR : On	SCAN FWD	A8-10
Scan FWD (Jump number is variable)	TR : On	Shuttle FWD	A8-28 to 2B
Loading in	STOP	SKIP REV	A8-53
Loading out	STOP	SKIP FWD	A8-52
Tilt neutral		SPEED DOWN	A8-46
Tilt servo on		SPEED UP	A8-47
Tilt servo off	Tilt : On/N	SKIP REV SKIP FWD	A8-53 A8-52
Tilt up	PLAY	SKIP FWD	A8-52
Tilt down	PLAY	SKIP REV	A8-53
LD on		TEST + 1	A8-5E + A8-01
Focus on		TEST + 2	A8-5E + A8-02
Focus sweep		TEST + 3	A8-5E + A8-03
Focus jump +		MULTI FWD	A8-58
Focus jump -		MULTI REV	A8-55
Spindle FG on		TEST + 5	A8-5E + A8-05
AGC on/off	AGC : Off/On	TEST + 7	A8-5E + A8-07
Indication of the FTS coefficient	After the address four-digit input	TEST + 9	A8-5E + A8-09
CD error rate indication	PLAY	TEST + 0	A8-5E + A8-00
Jitter indication		TEST + DIG/ANA	A8-5E + A8-0C
Screen indication on/Switching of the first screen and second screen	OSD Off/On	DISPLAY	A8-43
Screen indication off	OSD : On	AUDIO	A8-1E
Screen indication on/off		PROGRAM	A8-4C
Switching of ID display methods (decimal/hexadecimal)		DIG/ANA	A8-0C
DISC type designation	STOP	HILITE/INTRO	A8-5A
• Forced designation to DVD		+1	+A8-01
• Forced designation to CD		+3	+A8-03
• Request for Disk sensing		+0	+A8-00
Tray close of disk sense inhibition	Checker mode	REPEAT A	A8-48
Background color (eight colors) switching		2/R	A8-49
Background color (eight colors) switching (reverse toggle)		1/L	A8-4B
Video : component output		DIGITAL EFFECT	A8-5C
Video : composite output		STILL WITH SOUND	A8-5B

● Special Mention Item

- (1) Indications for the spindle status are as follows:
 A/B : Spindle accelerator and brake
 FG : FG servo
 SRV : Rough, velocity/phase servo
 O_S : Offset addition, rough, velocity/phase servo
- (2) The movement of loading in/out starts from the tray open status.
 After that, this function is executed unless a play and close operation are done.
- (3) There are three methods for entering a search address:
 - ① Absolute address designation
 → Searching for the address entered (indication for the most significant digit :>)
 - ② Additional input
 → Searching for the address with the current ID number plus an entered number
 (indication for the most significant digit :+)
 - ③ Subtractive input
 → Searching for the address with the current ID number minus an entered number(indication for the most significant digit :-)
 The above modes can be changed by pressing [10] key.
 Note : A number for addition or subtraction must be entered in hexadecimal.
- (4) If you turn the power on while short-circuiting the short-circuit terminal at the side of the system controller, the player will forcibly enter the test mode. If the FL controller is set to Checker mode, disc sensing will not be started, even if a disc is loaded. Disc sensing will also not be performed if the tray is open/closed by your pressing [REPEAT A] key while in Checker mode.
 However, disc sensing will be started if the [OPEN/CLOSE] key on the player or on the remote control unit is pressed.
- (5) If disc-type designation is forcibly executed during a mode other than Checker mode, the system controller will abandon disc-type designation after setting the mechanism controller. Therefore, after startup of the player, disc sensing will be performed again for safety.
 If disc-type designation is forcibly executed during Checker mode, as disc-type designation is not abandoned, playback will be immediately started.
- (6) A background color change in order of blue → green → light blue → red → purple → yellow → gray → black → with the [2/R] key.
 It changes in order of gray → yellow → purple → red → light blue → green → blue → black → in the case of the [1/L] key.
- (7) In case of PD0260A*, tilt servo on function may not move with DVD.

3.7 Test Mode Screen Display (The Second Generation)

Consecutive double-OSD display is supported during test mode. The screen is composed 10 lines with a maximum of 32 characters per line. It can't be used with the debugging display mode together.

• Screen Composition

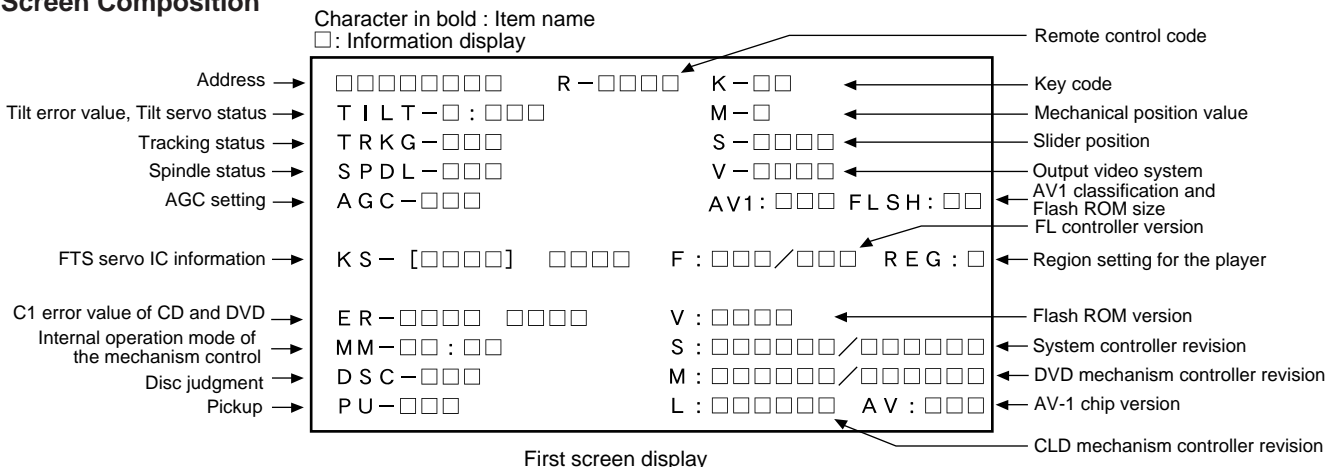

Caution :
 The first screen and second screen switch by pressing [DISPLAY] key of the remote control unit.
 It is only a version display part on the lower right of the screen those contents of display change.
 ATB : ON/OFF information display and AGC manual establishment display deleted with the second generation.

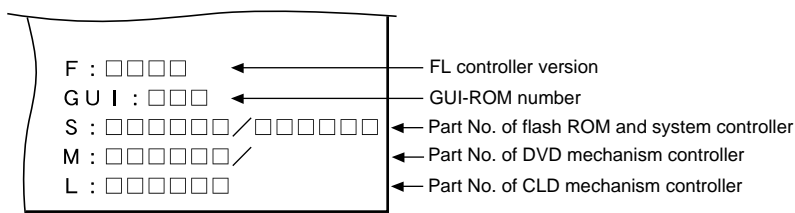

Second screen display (at lower right portion of the screen)

• Description of Each Item on the Display

(1) Address indication

The address being traced is displayed in number.

DVD : ID indication (hexadecimal number, 8 digits) [*****]
 CD/LD (CLV) : A-TIME (min. sec.) [○○○○****]
 LD (CAV) : FRAME [○○○****]
 (Note : For DVDs, decimal-number indication is possible.)

(2) Code indication of the remote control unit [R-****]

The code for the key pressed on the remote control unit, which is received by the FL controller, is displayed while the key is pressed. In the case of the double code, the second code will be displayed.

(3) Key code indication for the main unit [K-**]

The code for the key pressed on the main unit, which is received by the system controller, is displayed while the key is pressed.

(4) Tilt error value, Tilt servo status [TILT-*:***]

Tilt error value : [0] to [F]
 Tilt servo status :
 Tilt neutral [N]
 Tilt servo on [ON]
 Tilt servo off [OFF]

(5) Tracking status [TRKG-***]

Tracking on [ON]
 Tracking off [OFF]

(6) Spindle status [SPDL-***]

Spindle accelerator and brake [A/B]
 FG servo [FG]
 Rough, velocity phase servo [SRV]
 Offset addition, rough, velocity phase servo [O_S]

(7) Mechanism position value [M-*]

Position code [0] to [8]

(8) Slider position [S-****]

CD TOC area [IN]
 CD active area [CD]
 CDV video area [CDV]
 LD active area [LD]
 Side B inside [B IN]

(9) AGC setting [AGC-**]

AGC on [ON]
 AGC off [OFF]

(10) Output video system [V-****]

NTSC system [NTSC]
 PAL system [PAL]
 Auto-setting [AUTO]

(11) FTS servo IC information

Indications for the following two types of information can be switched:

- ① DSP coefficient indication [KS-[****] ****]
 Displays the address (four digits) of the specified coefficient and the setting value (four digits) with [TEST] and [9] keys.
- ② Jitter value indication [JT-[○○○○]****]
 Displays the jitter value (four digits) with [TEST] and [DIG/ANA] keys.

(12) Error rate indication

- ① C1 error value of CD [ER-C1 ****]
- ② C1 error value of DVD [ER-**** ****]

(13) Internal operation mode of mechanism controller [MM-***]**

Internal mechanism mode (2 digits) and internal mechanism step (2 digits) of the mechanism controller
 Note : For details, see the specifications of the mechanism controller.

(14) Disk sensing [DSC-***]

The type of discs loaded is displayed.
 [DVD], [CD], [CDV], [LD], [VCD], []

(15) Pickup [PU-***]

The pickup being operating is displayed.
 DVD [DVD]
 CLD [CLD]

(16) Destination setting of the FL controller [F:***/**]

Three characters in front represent the type of model:
 505: DV-505, S9: DV-S9
 606 : DV-606D, EDU: for education
 909: DVL-909, K88: DVL-K88.

Three characters that follow represent the destination code.
 J : /J, K: /KU, /KC, /KU/KC, RAM: /RAM (China)
 RL : /RL, WY: /WY, RD: /RD.

* Furthermore DVL-91/KU/CA indicates as L91/K.

(17) Region setting of the player [REG:*]

Setting value [1] to [6]

(18) Version of the flash ROM [V:*.**]

(19) Revision of the system controller [S:*.**/**.***]

- ① Revision number of the external ROM part (flash ROM) of the system controller <Front>
- ② Revision of the internal ROM part of the system controller <Rear>

(20) Revision of the DVD mechanism controller**[M:*.***/*.***]**

- ① Revision number of the external ROM part (flash ROM) of the DVD mechanism controller <Front>
- ② Revision of the internal ROM (core part) of the DVD mechanism controller <Rear>

(21) Revision of the CLD mechanism controller**[L:*.***]****(22) Version of the AV-1 chip [AV:*.]*****(23) Version of the FL controller [F:*.]*****(24) Control number of the GUI-ROM [GUI:***]****(25) The part number of the flash ROM and system controller [S : *****/*****]**

- ① Part number of the flash ROM <Front>
(Example) VYW1536-A → W1536A
(Example) PD626A9 → 6256A9
- ② Part number of the system controller <Rear>
(Example) PD3381T1 → 3381T1

(26) Part number of the DVD mechanism controller

(Example) PD4889A0 → 4889A0

(27) Part number of the CLD mechanism controller

(Example) PD0260A2 → 0260A2

(28) AV1 classification [AV1 : *]**

RAM, E/A, S/C

(29) Flash ROM size [FLSH : **]

8M : 8M bit, 4M : 4M bit

3.8 DESCRIPTIONS OF NEW FUNCTIONS IN TEST MODE**3.8.1 Error Rate****● Overview**

The error rate of CDs can be measured on basic models, such as the DV-505, and that of CDs as well as LDs with sub-Q codes can be measured on DVD/LD-compatible models, such as the DVL-909. The value is displayed in decimal and indicates the number of C1 errors (including the corrected ones) counted during the specified measurement time.

An indeterminate measurement result may be caused by a dirty disc, decentering, surface deflection, birefringence (double reflection), or a pickup problem (dirty lens, etc.), misadjustments of the pickup, improper automatic adjustment, or incomplete adjustments. On the manufacturing line, the value is used for yes/no decision of pickups. Normally, for a measurement for 5 seconds, the value may be less than 10 with a clean disc and less than 100 with a disc with some damage.

● Using the Function in Test Mode (The Remote Control Keys to be Used are Indicated in Brackets)

- (1) Set the CD to trace (playback) state.
- (2) Set the player to Number input mode by pressing [+10] and enter the measurement time in a range of 1 to 5 (sec.).
- (3) Start measurement by pressing [TEST] + [0]. The SubQ counter stops during measurement, but this is not a malfunction. When the specified measurement time has elapsed, the result is indicated to the right of "ER C1 -" on the screen. If you skip step 2, the measurement time is set to 5 (sec).

3.8.2 Jitter Value**● Overview**

The jitter values of DVDs and CDs can be displayed on basic models, such as the DV-505, and those of DVDs can be displayed on DVD/LD-compatible models, such as the DVL-909.

The displayed value shows a voltage in three-digit decimal as ○○○V. For example, the indication "0278" means 2.78 V. The larger the value, the worse the jitter. The worst value is 3.25 V. When playing a DVD or a video CD with which the jitter value is extremely high, mosaics may be seen. As with the error rate, the jitter depends on the disc and pickup. The jitter value to be displayed has no close correlation with a jitter measuring device, and is to be regarded just for reference.

Reference : When the jitter value is 2.9 V or more with a DVD, or 3.0 V or more with a CD (or a video CD), it may cause a problem (mosaic, audio distortion, etc.) in playback.

● Using the Function in Test Mode (The Remote Control Keys to be Used are Indicated in Brackets)

- (1) Set the DVD or CD to trace (playback) state with AGC OFF.
- (2) Press [TEST] and [DIGITAL/ANALOG].
The current jitter value appears to the right of "JT:○○○○" on the display. The jitter value keeps changing unless any additional key operation is made.

Note : Although a value may be displayed on the screen even with AGC ON, this is NOT a jitter value.

The jitter value with AFB ON cannot be displayed (see the next section). The jitter value with AFB ON can be obtained only by directly measuring the voltage at the JV connector (pin 94) of the servo DSP (LC78650).

3.8.3 Startup Sequence

The basic flow is shown below. The parentheses indicate a limitation: “base” represents base models, such as the DV-505 and DV-S9, and “compatibles” represents DVD-LD compatible models, such as the DVL-909.

- (1) Closes the tray.
- (2) Runs the tilt servo for 1.5 seconds (compatibles).
- (3) Detects the peak.
- (4) Distinguishes the disc.
- (5) SGC
- (6) Turns on the focus servo.
- (7) Turns on the tilt servo (compatibles).
- (8) Starts the spindle rotation.
- (9) ATB
- (10) Measures the MIRR modulation degree.
- (11) Turns on the tracking servo.
- (12) Turns on the slider servo.
- (13) Turns on the spindle servo.
- (14) Focus AGC
- (15) Tracking AGC
- (16) AFB
- (17) Plays AGC (base for CDs)
- (18) Plays back.

* For a 2-layer DVD, steps (9) through (16) are repeated for each layer.

* When starting up with [TV/LDP] in Test mode, all the steps (1) to (18) are performed for a DVD, and steps (1) to (10) are performed for a CD.

3.8.4 Peak Detection

● Overview

This is a new function to measure the size and location of the sine wave related to focus errors at the beginning. The measurement is performed in the normal startup process and in Test mode, as well. If the sine wave is small, the OE IC gain is switched. Only the judgment for NO DISC is accomplished at this time. The operation is in effect as for judgment for DISC.

● Using the Function in Test Mode

This function is not assigned to any remote control keys. Only an open/close operation can trigger the function.

3.8.5 Disc Distinction

● Overview

This function is almost the same as that with the first-generation models. The only difference is as follows: If an error occurs in the startup sequence and playback cannot be started, startup is retried after forcibly switching the disc distinction from DVD to CD or vice versa by a backup process. If startup fails again, it is canceled, and an error is generated. The types of error that triggers the backup process for disc distinction are discussed in the next section.

● Using the Function in Test Mode

This function is not assigned to any remote control keys. Only an open/close operation can trigger the function.

3.8.6 SGC

● Overview

This is a new function to maintain the sine wave related to focus errors to a certain size so that the sine wave shows 1.8 V for the P-to-P value.

This operation is performed each time after judging disc presence and distinction in the normal startup process and in Test mode, as well. The operation is achieved by switching the FE gain inside the RF IC (LA9700) by using the voltage at the SGC connector (pin 22) of the RF IC.

● Using the Function in Test Mode

This function is not assigned to any remote control keys. Only an open/close operation can trigger the function.

3.8.7 Measurement of MIRR Modulation Degree

● Overview

The slice voltage of the RF signal is measured and used in the calculation to generate the MIRR signal. This operation is made in synchronization with ATB ON/OFF in normal startup and in Test mode, as well.

3.8.8 AFB (Auto Focus Bias) Function

● Overview

Among the first-generation models, this function supports only CDs with the basic models, such as the DV-7. Among the new models, this function supports DVDs with all models, but CDs only with the basic models. The operation is executed only once (once for each layer for a 2-layer DVD) after the focus and tracking AGC at startup. The operation is accomplished not by centering the focus servo to Vref (2.5 V), but by gradually changing the center value for the optimum jitter value. Thus, performance with an improper or dirty disc (by fingerprints, etc.), or the temperature characteristics (at 0°C, 35°C, etc.) will be improved.

● Overview Using the Function in Test mode (the Remote Control Keys to be Used are Indicated in Brackets)

As the function is to be synchronized with AGC, turn on and off AFB by pressing [TEST] + [7]. The jitter value measurement cannot be made with AFB ON.

3.8.9 PLAY AGC

● Overview

The SGC voltage is adjusted during playback according to the RF signal level. (For details on SGC, see section 3.8.6.)

Only for CDs in basic models, such as the DV-505 (including the DV-S9), this adjustment is made only once immediately after AFB during startup. In Test mode, it synchronizes with AGC ON/OFF. The operation is achieved through adjustment in the Servo DSP (LC78650), and the SGC voltage is output via AUX0 (pin 44).

● Using the Function in Test Mode (the Remote Control Keys to be Used are Indicated in Brackets)

As the function is to be synchronized with AGC, turn on and off AFB by pressing [TEST] + [7].

3.9 Additional Descriptions of Error Generation

This section describes the major errors of the mechanism-control computer.

(1) DISC Distinction Error (Error 38)

The most common error. The tracking overcurrent error (Error c3), Defocus error (Error 33), spindle errors (Errors 41 to 4b), auto sequence errors (Errors 51 to 55) and code misread errors (71 to 74) often lead to this error.

(2) Search Errors (Errors 11, 12, 19)

Almost all cases where playback suddenly stops may involve these errors. They may be generated because of defects on the disc, or if the pickup goes too far over the inner periphery with DVD/LD-compatible models. As with the code misread errors below, they can also be generated by a dirty disc or bad jitters.

(3) Code Misread Errors (Errors 71 to 74)

Almost all cases where the inserted disc does not start or immediately stops playing may involve these errors. They may be generated because of a dirty disc or bad jitters. A bad jitter may be caused by a dirty disc, decentering, surface deflection, birefringence (double reflection), or a pickup problem (dirty lens, etc.), misadjustments of the pickup, improper automatic adjustment, or incomplete adjustments.

(4) Spindle Errors (Errors 48, 49)

An FG transition timeout (Error 48) may be generated because of instability of the FG signal or unavailability of spindle drive voltage. A PLL transition timeout (Error 49) can be generated with a dirty disc.

(5) Automatic Sequence Errors (Errors 51 to 55)

If any automatic sequence (auto execution command) of the servo DSP is not completed, these errors are generated. The causes differ among error numbers. They may be caused by abnormalities in the communication line between the mechanism-control computer (PD4889A) and the servo DSP or instability of the XABUSY connector (pin 38) of the mechanism-control computer.

(6) DSP Communication Errors (Errors a1 to a6)

These errors will be generated if the mechanism-control computer cannot properly communicate with the servo DSP. They may be caused by instability of the XCBUSY connector (pin 8) of the mechanism-control computer, instability of the communication line between the mechanism-control computer and the servo DSP, or a defect in the servo DSP.

(7) DVD Block Noise, etc.

Block noise and momentary picture freeze (*) with a DVD are not regarded as errors, but the causes of these symptoms in the Servo system may be:

- (1) A search takes a long time (leading to a search error if it worsens).
- (2) Codes cannot be read clearly (leading to a code misread error if it worsens).

If the value to the right in the "ER: ○:○e-" indication displayed on the screen by pressing the ESC and DISP keys of the remote control in Test mode is greater than 5, the cause may be (1). If the value is less than 3, the cause may be (2).

- (*) With a specific 2-layer disc with which playback continues from layer 1 to 2 or vice versa, the picture may be seen momentarily stop. This may be attributed to the performance of the player. Players of other manufacturers have the same symptoms to varying degrees.

4. IC INFORMATION

• The information shown in the list is basic information and may not correspond exactly to that shown in the schematic diagrams.

• List of IC

PD4890A, PD0260A2, PD0261A2, LA9700M, BA6195FP, LC78650E-P, PD4889A, SRM2B256SLMX70, VYW1536, PD3381A, MB86371, MB811171622A-100FN, CY2081SL-611, PD2058A

■ PD4890A (FLKB ASSY : IC101)

• Mode Control IC

• Block Diagram

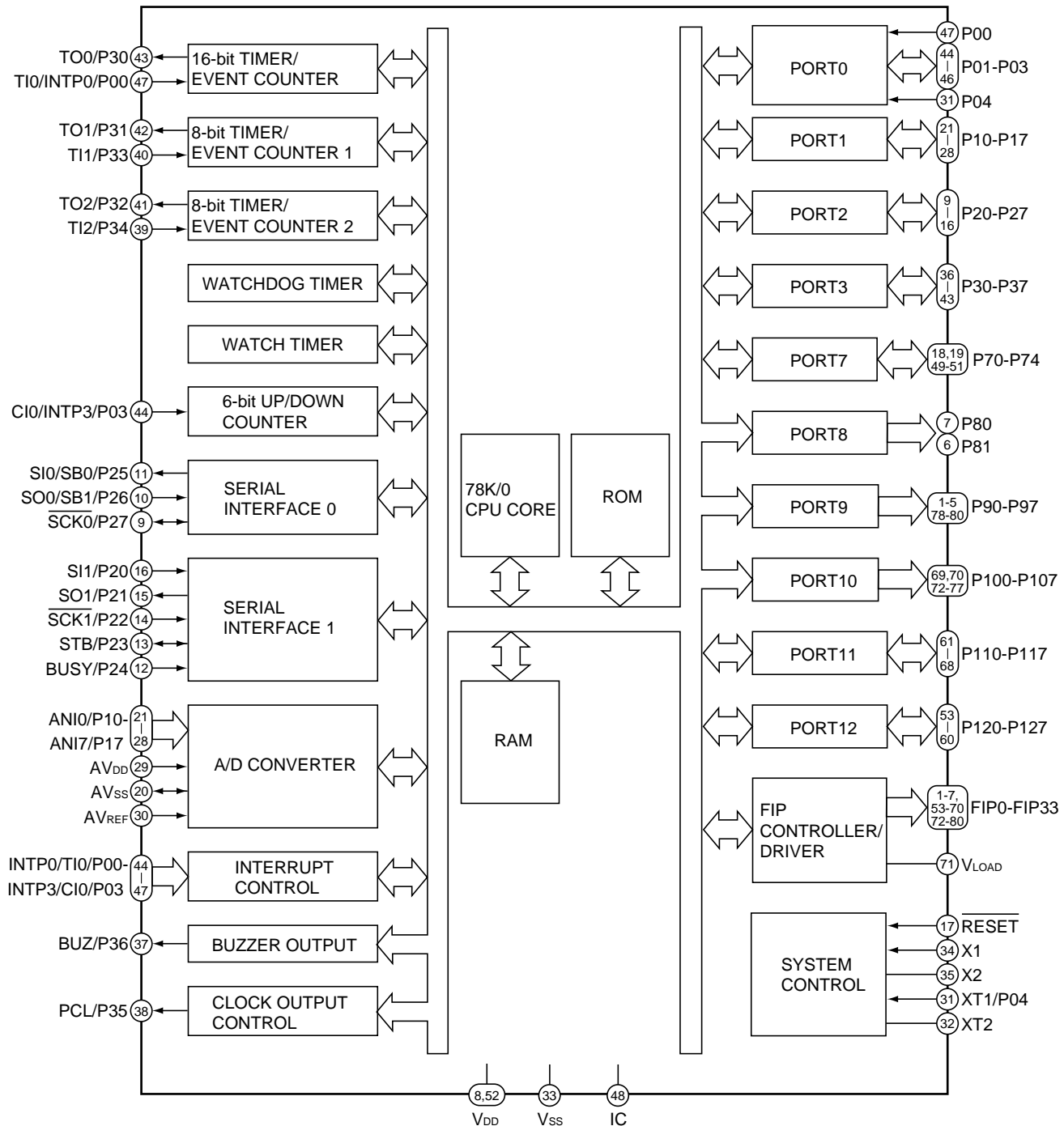

● Pin Function

No.	Mark	Pin Name	I/O	Function
1	P94	G7	O	FL timing output H : ON
2	P93	G6		
3	P92	G5		
4	P91	G4		
5	P90	G3		
6	P81	G2		
7	P80	G1		
8	VDD	VCC	-	Power supply pin
9	P27	(NC)	O	Not used
10	P26	(NC)		
11	P25	(NC)		
12	P24	LAMP	O	DVD lamp ON/OFF H : ON
13	P23	XREADY	O	Communication handshake line with the system controller L : Permit the communication
14	P22	SCK	I/O	Communication clock output with the system controller
15	P21	SO	I/O	Communication data output with the system controller
16	P20	SI	I	Communication data input with the system controller
17	RESET	RESET IN	I	Reset input L : reset
18	P74	(NC) (DV-505)	O	Not used
		SIDE A LED (DVL-909)	O	SIDE A LED ON/OFF L : ON
19	P73	(NC) (DV-505)	O	Not used
		SIDE B LED (DVL-909)	O	SIDE B LED ON/OFF L : ON
20	AVss	Vss	-	GND pin
21	P17	POWER ON	O	SW 5V ON/OFF H : ON
22	P16	RESET OUT	O	System reset output L : reset
23	P15	(NC)	O	Not used
24	P14	(NC)		
25	P13	KIN1	I	Key input
26	P12	KIN0		
27	P11	MS1	I	Destination judgement input
28	P10	MS0		
29	AVDD	AVDD	-	Power supply pin
30	AVREF	AVREF	-	Reference voltage
31	P04	P04	I	Not used
32	XT2	(NC)	-	Not used
33	VSS	VSS	-	GND pin
34	X1	X1	I	Connect a microprocessor clock
35	X2	X2	-	
36	P37	(NC)	O	Not used
37	P36	(NC)		
38	P35	(NC)		
39	P34	P34	I	Not used
40	P33	P33		

DV-505, DVL-909, DV-S9

No.	Mark	Pin Name	I/O	Function
41	P32	P32	I	Not used
42	P31	P31		
43	P30	(NC)	I	Not used
44	P03	P03	I	Not used
45	P02	ON POWER	I	Switch the STBY/POWER ON at rising edge the FL controller L : STBY
46	P01	LT	I	Communication handshake line with the system controller H : Permit the communication
47	P00	SEL IR	I	Remote control signal input
48	IC	IC	-	-----
49	P72	(NC)	O	Not used
50	P71	FL OFF LED (DV-505)	O	FL OFF LED ON/OFF L : ON
		(NC) (DVL-909)	O	Not used
51	P70	(NC)	O	Not used
52	VDD	VDD	-	Power supply pin
53	P127	(NC) (DV-505)	O	Not used
		FL OFF LED (DVL-909)	O	FL OFF LED ON/OFF H : ON
54	P126	(NC)	O	Not used
55	P125	(NC)		
56	P124	(NC)		
57	P123	(NC)		
58	P122	(NC)		
59	P121	(NC)		
60	P120	(NC)		
61	P117	P15	O	FL segment output H : ON
62	P116	P14		
63	P115	P13		
64	P114	P12		
65	P113	P11		
66	P112	P10		
67	P111	P9		
68	P110	P8		
69	P107	P7		
70	P106	P6		
71	VLOAD	-27V	-	- 27V input H : ON
72	P105	P5	O	FL segment output H : ON
73	P104	P4		
74	P103	P3		
75	P102	P2		
76	P101	P1		
77	P100	G11	O	FL timing output H : ON
78	P97	G10		
79	P96	G9		
80	P95	G8		

■ PD0260A2, PD0261A2 (CLDM ASSY : IC101)(DVL-909 ONLY)

• Mechanism Control IC

• Pin Function

No.	Pin Name	I/O	Function
1	VCC	I	Power supply pin Apply 5V ± 10%
2	RWC	O	DSP read/write command signal output "L"= Read "H"= Write
3	XPLAY	O	Signal output during spindle servo "L"= During servo "H"= During acceleration, brake and stop
4	CLK:SCK3/CQCK	O	DVP/DSP clock switch "H"= DVP "L"= DSP
5	XCD	O	LD/CD switch signal output "L"= CD "H"= LD
6	TILT ERR	I	A/D • This signal is A/D converted as the tilt servo control input. Control the tilt motor so that this signal becomes 2.5V.
7	TRK BAL ERR	I	A/D • Tracking balance error signal input This signal is A/D converted as the tracking offset control input.
8	SLD ERR	I	A/D • This signal is A/D converted as the slider servo control input. Control the slider motor so that this signal becomes 2.5V.
9	SLD POS	I	A/D • Pickup position detection switch input Detect the position by reading A/D input value which each switches are resistance divided.
10	FSEQ	I	Subcode sync. confirmity detection signal input "L"= Not confirmity "H"= Confirmity
11	C DETECT	I	Spindle over-current detection signal input "L" = Over current "H"= Normal
12	TRK BAL DRV	O	PWM • Output the tracking offset signal to PWM output, then use for auto tracking offset. 910 μsec period, tri-state control H, L, Z
13	SHAKE	I/O	Handshake signal for data communication with the DVD mechanism control IC This pin is the bilateral data line and each microprocessor control the Input/Output.
14	RF CORRECTION	O	RF correction switch signal output "H"= Gain UP CD, CDV-A:Low, CAV inner circuit gain up, others are High.
15	SQOUT	I	Command data input from DSP Read out SUBQ
16	SO3/COIN	O	Command data output to DVP/DSP
17	SCK3/CQCK	O	DVP/DSP read/write command clock output Read-in at rising edge
18	SLD OUT	O	PWM • Slider control signal output 5V= FWD, 0V= REV, 2.5V= STOP 910 μsec period, tri-state control
19	SI1	I	Data input from the DVD mechanism control IC
20	SO1	O	Serial data output to the DVD mechanism control IC
21	SCK	I/O	Clock for serial communication with the DVD mechanism control IC Becomes input mode without communicate with the DVD mechanism control IC
22	TRK 0 CRS	I	INT • Tracking error zero cross signal input Monitor this signal when searching track count in the miss clamp detection
23	SBSY	I	Subcode block sync. input
24	TILT OUT	I/O	LOAD/TILT control output PWM output 0V : Tray IN / Tilt DOWN, 5V : Tray OUT / Tilt UP, 2.5V : STOP
25	TURN OUT	O	Turn drive signal output
26	XPBV	I	Playback vertical sync. signal input of LD/CDV "L"= During vertical sync.
27	CNVSS	I	Ground for A/D conversion
28	XRESET	I	Reset signal input "L"= Reset "H"= Release reset Control with the DVD mechanism control IC.
29	XIN	I	9MHz clock oscillation input
30	XOUT	O	9MHz clock oscillation output

DV-505, DVL-909, DV-S9

No.	Pin Name	I/O	Function
31	PHAI	O	Not used
32	GND	I	Ground
33	SW1	I	Switch input for Loading/Tilt position detection
34	SW3		
35	SW2		
36	TBCLOCK	I	Spindle lock signal input "L"= Unlock "H"= Lock
37	FG	I	Spindle motor FG signal input 16 outputs per rotation Used after dividing by 2 in the microprocessor
38	DATA	I	Input for Phillips code decoder with built-in mechanism controller
39	XPBH	I	Playback H-SYNC input for Phillips code decoder
40	XPBV	I	Playback V-SYNC input for Phillips code decoder
41	DEXT	O	Control signal output of video dynamic range extension "H"= ON "L"= OFF
42	WFM/VLOCK	I	Field discrimination signal from DVP "H"= ODD "L"= EVEN (with memory) VLOCK signal at clear scan (with no memory)
43	LATMEM	O	Serial control latch output of memory control IC PD3212A Latches at falling edge.
44	XPFR	O	PD0260A2 : 17MHz PLL control signal output H : Phase comparison L : Free-run PD0261A2 : Not used
45	XP/N2	O	PD0260A2 : NTSC/XPAL circuit switching signal output excepting VDEM H : NTSC L : PAL PD0261A2 : Not used
46	HQ	O	PD0260A2 : Control signal output of the High Quality circuit (analog NR) H : Through the HQ circuit L : Not through PD0261A2 : Not used
47	THLD	I	Track jump accelerating / decelerating signal input "L"= Others "H"= During accelerating / decelerating
48	LATDVP	O	PD6159B serial latch signal output Latches at falling edge.
49	SELTZC	O	TZC switch signal output "H"= at normal "L"= at CD/DVD disc discrimination
50	DOCINH	O	Control the clamp pulse and clamp killer circuit by tri-state value
51	XP/N1	O	PD0260A2 : NTSC/XPAL circuit switching signal output for VDEM H : NTSC L : PAL PD0261A2 : Not used
52	NROFF	O	Noise reduction control output by VDEM "L"= Normal "H"= Not NR
53	DSCDET	I	Disc present/absent detecting signal input by the tilt sum in the DVD P.U. mode "H"= Absent "L"= Present DEFECT input at LD P.U.
54	XTURNB	I	Turn switch input "H"= Side A / turn "L"= Side B
55	XTURNA	I	Turn switch input "H"= Side B / turn "L"= Side A
56	XLPO	I	LD P.U. out position detecting switch input "H"= LD P.U. active "L"= LD P.U. out position
57	VDET	I	Use for power abnormal signal input port "L"= Normal "H"= Abnormal
58	XFOK	I	Focus servo lock signal input "L"= Lock "H"= Unlock Use for lock detection of focus servo
59	WRQ	I	Subcode Q reading OK signal input "L"= NG "H"= OK This pin will be H when subcode Q data passed by CRC check.
60	AC3MUTE	O	Mute control signal output for AC3 Release MUTE during playback. "L"= Release MUTE "H"= MUTE
61	SQ1	O	Analog audio switching signal output 1/L "L"= Squelch OFF "H"= Squelch ON
62	SQ2	O	Analog audio switching signal output 2/R "L"= Squelch OFF "H"= Squelch ON
63	XCX	O	Analog audio CX noise reduction switching signal output "L"= CX ON "H"= CX OFF
64	XANA	O	Digital / Analog audio switching signal output "L"= Analog "H"= Digital

■ LA9700M (DVDM ASSY : IC101)

• RF IC

• Block Diagram

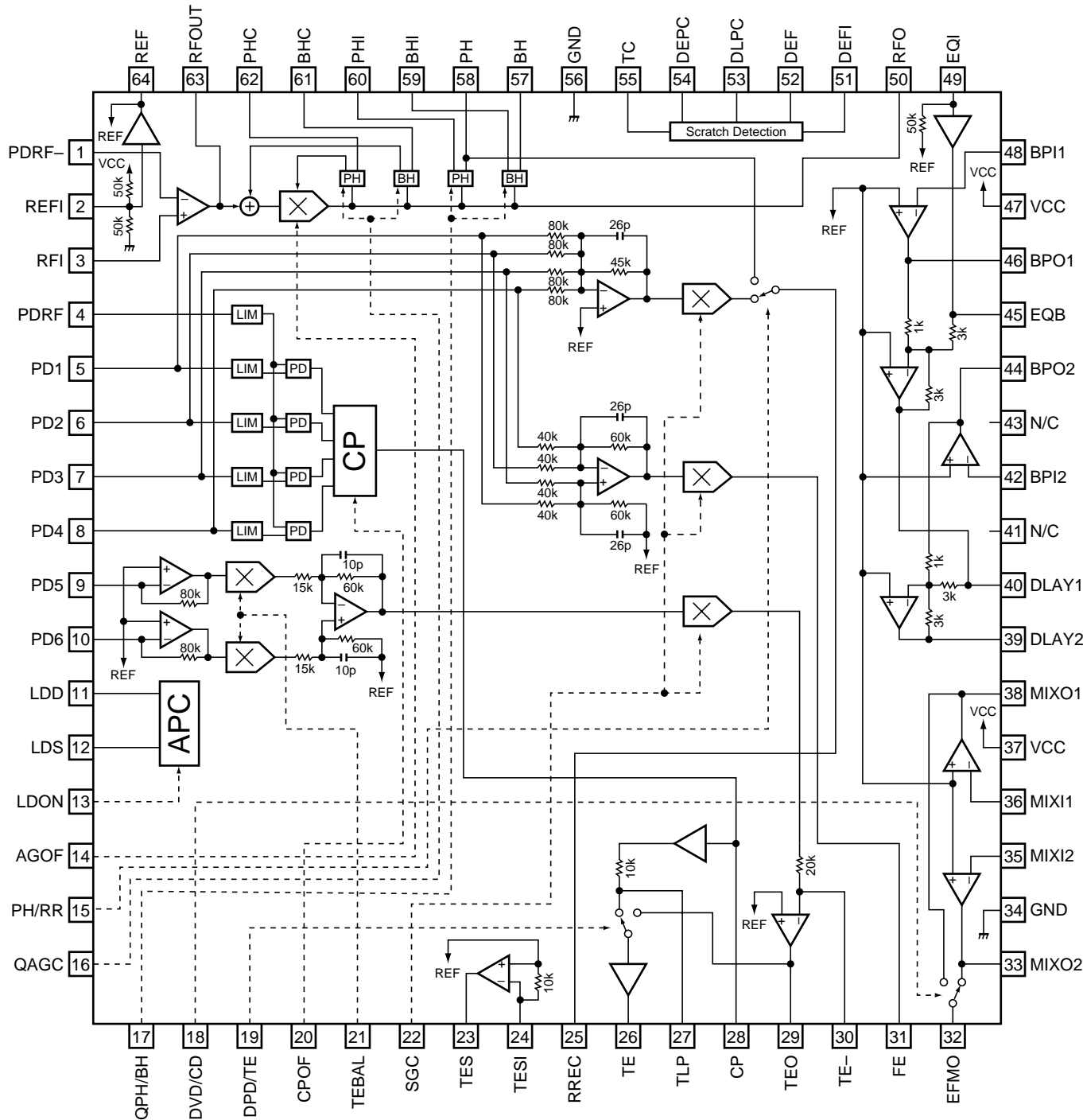

BA6195FP (DVDM ASSY : IC161)

• Spindle Driver

• Block Diagram

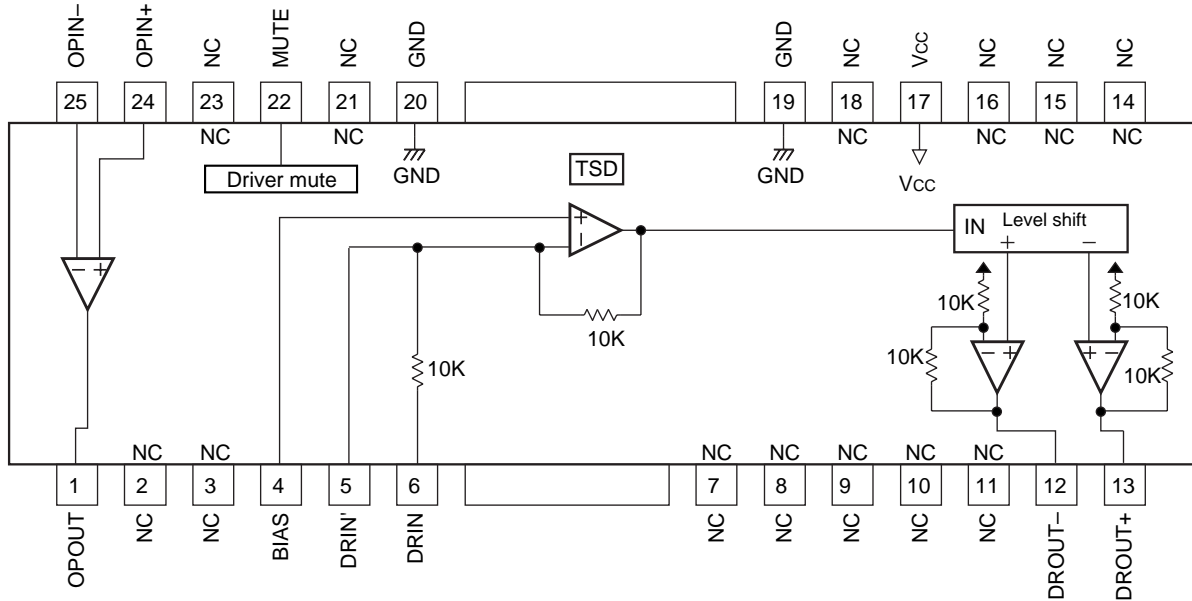

• Pin Function

No.	Pin Name	Function	No.	Pin Name	Function
1	OPOUT	OP amp. output pin	14	N.C.	Non Connection
2	N.C.	Non Connection	15	N.C.	
3	N.C.		16	N.C.	
4	BIAS	Bias pin	17	VCC	Power supply pin
5	DRIN'	Driver gain adjustment pin	18	N.C.	Non Connection
6	DRIN	Driver gain input pin	19	GND	Sub-strait GND pin
7	N.C.	Non Connection	20	GND	
8	N.C.		21	N.C.	Non Connection
9	N.C.		22	MUTE	Mute pin
10	N.C.		23	N.C.	Non Connection
11	N.C.		24	OPIN +	OP amp. non-inverting input pin
12	DROUT -	Driver negative output pin (for input)	25	OPIN -	OP amp. inverting input pin
13	DROUT +	Driver positive output pin (for input)			

■ LC78650E-P (DVDM ASSY : IC201)(DVL-909 only)

• Servo DSP LSI

• Block Diagram

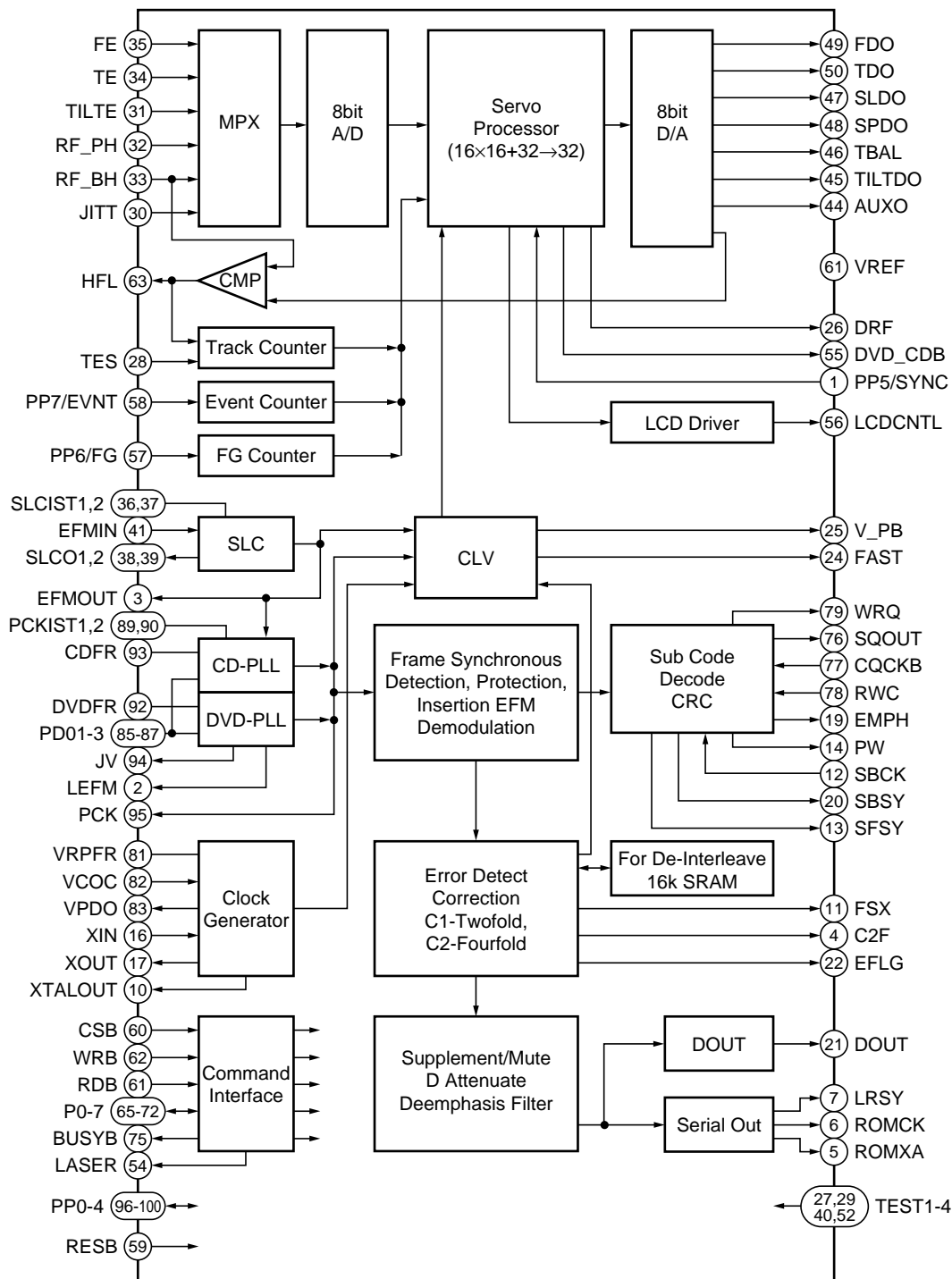

DV-505, DVL-909, DV-S9

● Pin Function

No.	Pin Name	I/O	Function
1	PP5/SYNC	I/O	General-purpose port input/output / DVD sync. signal input
2	LEFM	O	Output the state that cut and out a signal which was binary-stated value EFM/EFM + with PCK.
3	EFMOUT	O	Output the state that was binary-stated value EFM/EFM + .
4	C2F	O	C2 flag output
5	ROMXA	O	ROMXA data output
6	ROMCK	O	Shift clock output for ROMXA data output
7	LRSY	O	L/R clock output for ROMXA data output
8	DVDD2	-	5V power supply
9	VSS	-	GND
10	XTALOUT	O	External system clock output
11	FSX	O	CD 1 frame sync. signal output
12	SBCK	I	Subcode reading out clock input
13	SFSY	O	Frame sync. signal output of subcode
14	PW	O	Subcode P, Q, R, S, T, U, V and W output
15	VSS	-	GND for oscillation circuit
16	XIN	I	Connect a crystal resonator (16.9344MHz)
17	XOUT	O	Connect a crystal resonator
18	DVDD1	-	3.3V power supply of the oscillation circuit
19	EMPH	O	Monitor the deemphasis
20	SBSY	O	Sync. signal output of the subcode block
21	DOUT	O	Output for the digital audio I/F
22	EFLG	O	Error correction state monitor of the error correction C1 and C2
23	FSEQ	O	Detection monitor of the CD/DVD frame sync. signal
24	FAST	O	Playback speed monitor
25	V_PB	O	Monitor output of the rough servo/CLV control
26	DRF	O	In focus monitor
27	TEST3	I	Test input 3
28	TES	I	Tracking error signal input
29	TEST2	I	Test input 2
30	JITT	I	Jitter quantity detecting signal input of EFM/EFM + PLL
31	TILTE	I	Tilt error signal input
32	RF_PH	I	RF peak hold signal input
33	RF_BH	I	RF bottom hold signal input
34	TE	I	Tracking error signal input
35	FE	I	Focus error signal input
36	SLCIST1	-	Current setting pin 1 of the constant current charge pump for SLC
37	SLCIST2	-	Current setting pin 2 of the constant current charge pump for SLC
38	SLCO1	-	Control output 1 for SLC
39	SLCO2	-	Control output 2 for SLC
40	TEST1	I	Test input 1
41	EFMIN	I	EFM/EFM + input
42	AVDD	-	5V power supply of A/D and D/A for servo
43	AVSS	-	GND of A/D and D/A for servo
44	AUXO	O	DA auxiliary output
45	TILTDO	O	Tilt control signal output
46	TBAL	O	Tracking balance control signal output
47	SLDO	O	Sled control signal output
48	SPDO	O	Spindle control signal output
49	FDO	O	Focus control signal output
50	TDO	O	Tracking control signal output

No.	Pin Name	I/O	Function
51	VREF	–	Reference level of A/D and D/A for servo
52	TEST4	I	Test input 4
53	HFL	O	Track detection signal output
54	LASER	O	For laser ON/OFF control
55	DVD_CDB	O	Disc discrimination result output
56	LCDCNTL	O	Pickup liquid shutter control signal output
57	PP6/FG	I/O	General-purpose port input/output / FG signal input
58	PP7/EVNT	I/O	General-purpose port input/output / Event counter input
59	RESB	I	Reset input
60	CSB	I	Chip select input
61	RDB	I	Internal state reading signal input
62	WRB	I	Command / data writing signal input
63	DVDD2	–	5V power supply
64	VSS	–	GND
65	P0	I/O	Command / data input/output
66	P1		
67	P2		
68	P3		
69	P4		
70	P5		
71	P6		
72	P7		
73	VSS	–	GND
74	DVDD1	–	3.3V power supply for internal logic
75	BUSYB	O	Busy signal output of command process
76	SQOUT	O	Serial output of subcode Q
77	CQCKB	I	Data read-out shift clock input of subcode Q
78	RWC	I	Serial output update permission input of subcode Q
79	WRQ	O	Read out ready monitor of subcode Q
80	VSS	–	PLL GND for internal system clock
81	VRPFR	–	VCO oscillation range setting of PLL for internal system clock
82	VCOC	–	Connect a PLL filter for internal system clock
83	VPDO		
84	DVDD2	–	PLL 5V power supply for internal system clock
85	PDO1	–	PLL filter connection pin 1 for EFM/EFM + playback
86	PDO2	–	PLL filter connection pin 2 for EFM/EFM + playback
87	PDO3	–	PLL filter connection pin 3 for EFM/EFM + playback
88	VSS	–	PLL GND for EFM/EFM + playback
89	PCKIST1	–	Current setting 1 of PLL constant current charge pump for EFM/EFM + playback
90	PCKIST2	–	Current setting 2 of PLL constant current charge pump for EFM/EFM + playback
91	DVDD2	–	PLL 5V power supply for EFM/EFM + playback
92	DVDFR	–	VCO oscillation range setting of PLL for EFM + playback
93	CDFR	–	VCO oscillation range setting of PLL for EFM playback
94	JV	O	Jitter monitor of PLL clock for EFM/EFM + playback
95	PCK	O	Bit clock output for EFM/EFM + playback
96	PP0	I/O	General-purpose port input/output
97	PP1		
98	PP2		
99	PP3		
100	PP4		

■ PD4889A (DVDM ASSY : IC501)

• Mechanism Control IC

• Pin Function

No.	Pin Name	I/O	Function	No.	Pin Name	I/O	Function
1	LODDR	I/O	Loading motor drive output	33	XDSPRST	-	Reset pulse for servo DSP "L"
2	DVD/XCD	O	Clock switch H : DVD , L : CD	34	ASTB	O	Address strobe of multiplexed address/data bus "H"
3	AGOFF	O	Turn AGC of RF IC to OFF for "H"	35	XRST	I	CPU reset input "L"
4	EFLG	I	Count data input of error rate Measureable by using timer 1 and 2.	36	SBSY	INT	Subcode frame sync. input (H : S0+S1 period)
5	FSX	I	Error rate count area input (EFM frame sync.) H : C1 , L : C2	37	SHAKE	INT	Communication handshake of CLD mechanism controller "L" (DVL-909 only)
6	P35/PCL	-	Not used (pull down)	38	XABUSY	INT	DSP auto sequence busy input "L"
7	XTOFF	I/O	High impedance (input) at DEFECT ON "L" output at DEFECT OFF	39	XIRQ2	INT	LSI-11 interrupt input "L"
8	XCBUSY	I	DVD command reception is possible "L"	40	VDD	-	Power supply pin
9	VSS	-	GND	41	X2	-	Connect a ceramic resonator
10	MAD0	I/O	External address / data bus	42	X1	-	
11	MAD1			43	IC (Vpp)	-	GND
12	MAD2			44	XT2	-	Not used
13	MAD3			45	DVDPPK	I	Park position detection of compatible DVD pickup "L" (DVL-909 only)
14	MAD4			46	AVss	-	GND
15	MAD5			47	LODPOS	I	Loading and clamp position SW input
16	MAD6			48	SLDPOS	I	Slider position SW input
17	MAD7			49	DORPOS	I	Panel position SW input (DV-S9 only)
18	MA8	O	External address bus	50	XCURDET	I	Acuator over-current detection input (former TRDLMT) "L" Servo OFF for 300 ms.
19	MA9			51	DR/XLD	O	Panel and loading switch of PWM output Panel : H , loading : L (DV-S9 only)
20	MA10			52	MON	O	Spindle motor ON output "H"
21	MA11			53	XCD2X	O	Not used
22	MA12			54	OEICG	O	"H" : OEIC gain up to 6dB
23	MA13			55	AVDD	-	Power supply pin
24	VSS	-	GND	56	AVREF	-	Reference power supply pin
25	MA14	O	External address bus	57	P_ERR	O	Not used
26	MA15			58	P21/SO1	-	Not used (pull down)
27	DRF	I	(FOK) Focus OK input	59	P22/XSK1	-	Not used (pull down)
28	V_PB	I	(LOCK) EFM servo lock signal "H"/"L"= rough servo / phase servo	60	XCSB	O	DSP parallel command setting output "L"
29	P62	-	Not used (pull down)	61	CLD	O	CLD circuit block switch (DVL-909 only)
30	WRQ	I	Readable flag of subcode Q	62	LDSO	I	Inputs serial communication output of CLD mechanism controller (DVL-909 only)
31	XRD	O	CPU read pulse "L"	63	LDSI	O	Outputs serial communication input of CLD mechanism controller (DVL-909 only)
32	XWR	O	CPU write pulse "L"	64	LDSCK	I	Inputs serial communication clock output of CLD mechanism controller (DVL-909 only)

■ SRM2B256SLMX70 (DVDM ASSY : IC502)

- 256 K SRAM (For Mechanism Control IC)

● Block Diagram

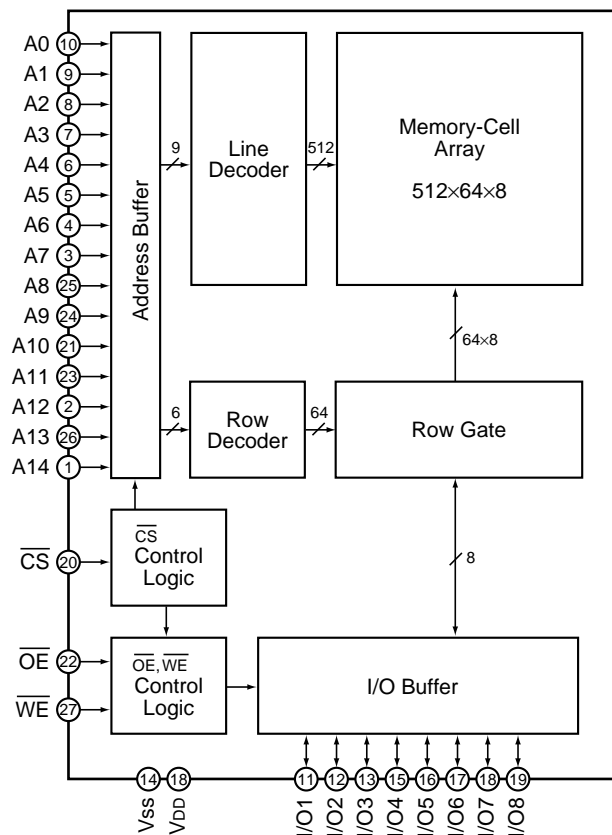

● Pin Function

No.	Pin Name	Function	No.	Pin Name	Function
1	A14	Address input	15	I/O4	Data input/output
2	A12		16	I/O5	
3	A7		17	I/O6	
4	A6		18	I/O7	
5	A5		19	I/O8	
6	A4		20	\overline{CS}	Chip select
7	A3		21	A10	Address input
8	A2		22	\overline{OE}	Output enable
9	A1		23	A11	Address input
10	A0		24	A9	
11	I/O1	25	A8		
12	I/O2	Data input/output	26	A13	Write enable
13	I/O3		27	\overline{WE}	
14	VSS	GND (0V)	28	VDD	Power supply (2.7 to 5.5V)

■ VYW1536 (DVDM ASSY : IC603)(DV-505 and DVL-909 only)

- Flash ROM

• Block Diagram

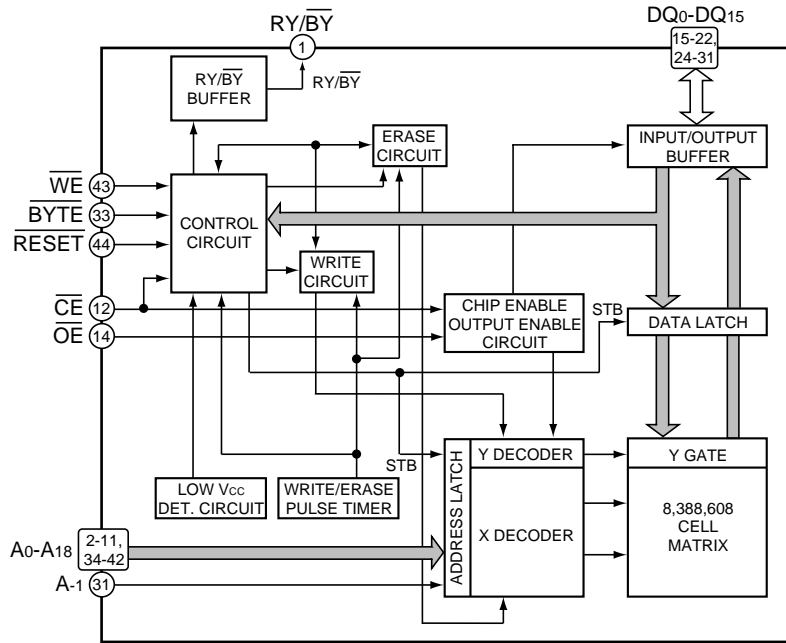

• Pin Function

No.	Pin Name	Function	No.	Pin Name	Function	
1	RY/ $\overline{\text{BY}}$	Ready / Busy output	23	VCC	Power supply (+5.0V \pm 10% or \pm 5%)	
2	A18	Address input	24	DQ4	Data input / output	
3	A17					
4	A7					
5	A6					
6	A5					
7	A4					
8	A3					
9	A2					
10	A1					
11	A0			27	DQ13	
12	$\overline{\text{CE}}$	Chip enable	28	DQ6		
13	VSS	Ground	29	DQ14		
14	$\overline{\text{OE}}$	Output enable	30	DQ7		
15	DQ0	Data input/output	31	DQ15/A-1	Data input/output / address input	
16	DQ8					
17	DQ1					
18	DQ9					
19	DQ2					
20	DQ10					
21	DQ3					
22	DQ11					
				32	VSS	Ground
				33	$\overline{\text{BYTE}}$	Switch the 8 bit and 16 bit modes
			34	A16	Address input	
			35	A15		
			36	A14		
			37	A13		
			38	A12		
			39	A11		
			40	A10		
			41	A9		
			42	A8		
			43	$\overline{\text{WE}}$	Write enable	
			44	$\overline{\text{RESET}}$	Hardware reset	

■ PD3381A (DVDM ASSY : IC601)

• System Control CPU

• Block Diagram

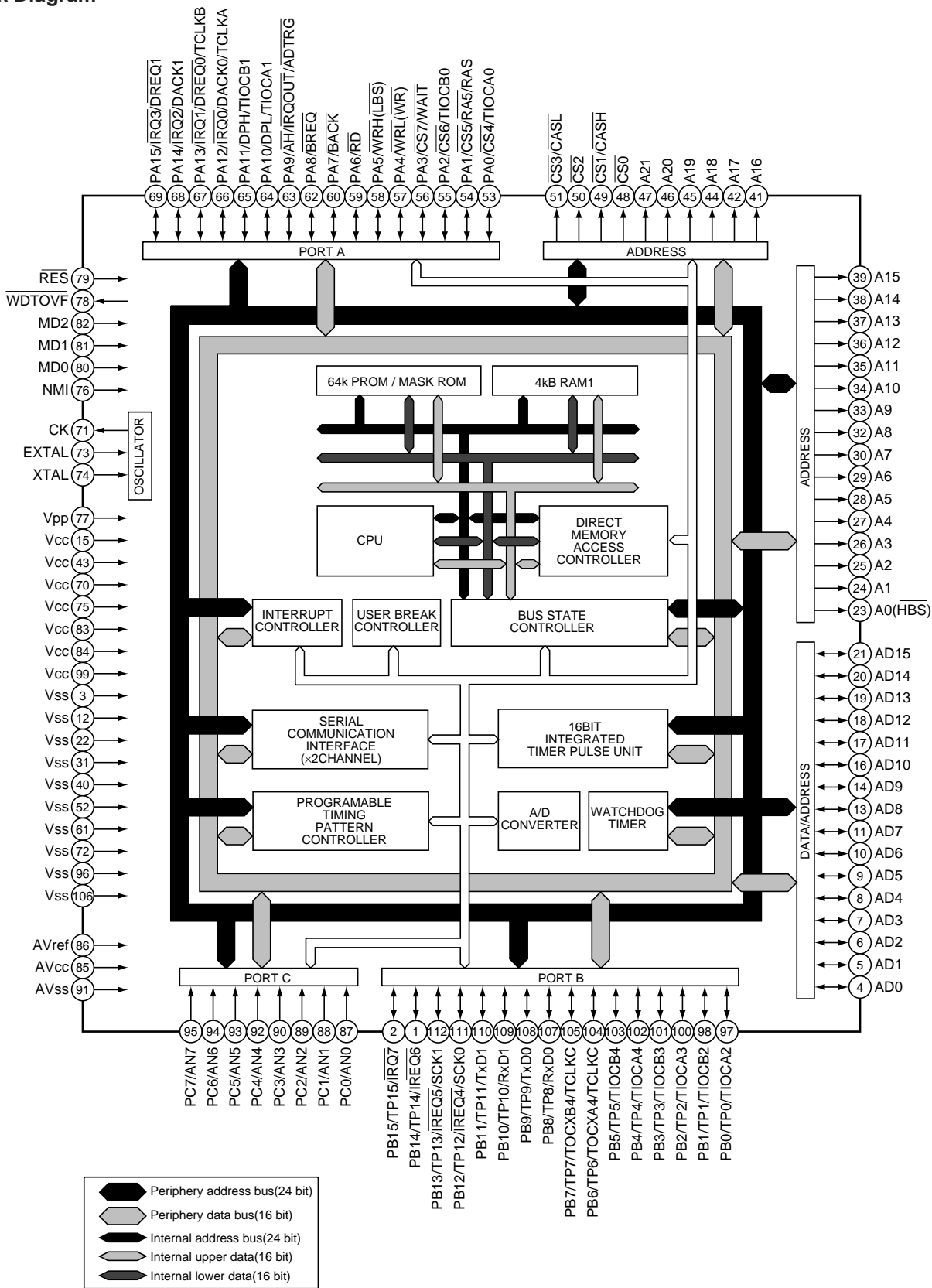

● Pin Function

No.	Pin Name	I/O	Function
1	PB14/TP14/ $\overline{\text{IRQ6}}$	I/O	16 bit input/output (port B) / Timing pattern output / Interruption request
2	PB15/TP15/ $\overline{\text{IRQ7}}$		
3	VSS	I	Ground
4	AD0	I/O	16 bit bilateral data bus
5	AD1		
6	AD2		
7	AD3		
8	AD4		
9	AD5		
10	AD6		
11	AD7		
12	VSS	I	Ground
13	AD8	I/O	16 bit bilateral data bus
14	AD9		
15	VCC	I	Power supply
16	AD10	I/O	16 bit bilateral data bus
17	AD11		
18	AD12		
19	AD13		
20	AD14		
21	AD15		
22	VSS	I	Ground
23	A0 ($\overline{\text{HBS}}$)	O	Address bus output (upper byte strobe signal)
24	A1	O	Address bus output
25	A2		
26	A3		
27	A4		
28	A5		
29	A6		
30	A7		
31	VSS	I	Ground
32	A8	O	Address bus output
33	A9		
34	A10		
35	A11		
36	A12		
37	A13		
38	A14		
39	A15		
40	VSS	I	Ground
41	A16	O	Address bus output
42	A17		
43	VCC	I	Power supply

No.	Pin Name	I/O	Function
44	A18	O	Address bus output
45	A19		
46	A20		
47	A21		
48	$\overline{CS0}$	O	Chip select signal
49	$\overline{CS1}/\overline{CASH}$	O	Chip select signal / Column address strobe timing signal on the upper side of DRAM
50	$\overline{CS2}$	O	Chip select signal
51	$\overline{CS3}/\overline{CASL}$	O	Chip select signal / Column address strobe timing signal on the lower side of DRAM
52	VSS	I	Ground
53	$\overline{PA0}/\overline{CS4}/\overline{TIOCA0}$	I/O	16 bit input/output (port A) / Chip select signal / ITU input capture input/ITU output compare output (channel 0)
54	$\overline{PA1}/\overline{CS5}/\overline{RAS}$	I/O	16 bit input/output (port A) / Chip select signal / Low address strobe timing signal of DRAM
55	$\overline{PA2}/\overline{CS6}/\overline{TIOCB0}$	I/O	16 bit input/output (port A) / Chip select signal / ITU input capture input/ITU output compare output (channel 0)
56	$\overline{PA3}/\overline{CS7}/\overline{WAIT}$	I/O	16 bit input/output (port A) / Chip select signal / Wait input for bus cycle
57	$\overline{PA4}/\overline{WRL}$ (\overline{WR})	I/O	16 bit input/output (port A) / External lower 8 bit writing (output at writing)
58	$\overline{PA5}/\overline{WRH}$ (\overline{LBS})	I/O	16 bit input/output (port A) / External upper 8 bit writing (lower byte strobe signal)
59	$\overline{PA6}/\overline{RD}$	I/O	16 bit input/output (port A) / External reading out
60	$\overline{PA7}/\overline{BACK}$	I/O	16 bit input/output (port A) / Bus claim request acknowledge
61	VSS	I	Ground
62	$\overline{PA8}/\overline{BREQ}$	I/O	16 bit input/output (port A) / Bus claim request
63	$\overline{PA9}/\overline{AH}/\overline{IRQOUT}/\overline{ADTRG}$	I/O	16 bit input/output (port A) / Address hold timing signal / Interruption request output at slave / A/D conversion trigger input
64	$\overline{PA10}/\overline{DPL}/\overline{TIOCA1}$	I/O	16 bit input/output (port A) / Data bus parity on the lower side / ITU input capture input/ITU output compare output (channel 1)
65	$\overline{PA11}/\overline{DPH}/\overline{TIOCB1}$	I/O	16 bit input/output (port A) / Data bus parity on the upper side / ITU input capture input/ITU output compare output (channel 1)
66	$\overline{PA12}/\overline{IRQ0}/\overline{DACK0}/\overline{TCLKA}$	I/O	16 bit input/output (port A) / Interruption request / DMA transfer request reception (channel 0) / ITU timer clock input
67	$\overline{PA13}/\overline{IRQ1}/\overline{DREQ0}/\overline{TCLKB}$	I/O	16 bit input/output (port A) / Interruption request / DMA transfer request (channel 0) / ITU timer clock input
68	$\overline{PA14}/\overline{IRQ2}/\overline{DACK1}$	I/O	16 bit input/output (port A) / Interruption request / DMA transfer request reception (channel 1)
69	$\overline{PA15}/\overline{IRQ3}/\overline{DREQ1}$	I/O	16 bit input/output (port A) / Interruption request / DMA transfer request (channel 1)
70	VCC	I	Power supply
71	CK	O	System clock output
72	VSS	I	Ground
73	EXTAL	I	Crystal oscillator input External clock input
74	XTAL	I	Crystal oscillator input
75	VCC	I	Power supply
76	NMI	I	Non-maskable interruption input
77	VPP	I	Power supply of PROM program
78	\overline{WDOVF}	O	Watchdog timer over-flow output
79	\overline{RES}	I	Reset input
80	MD0	I	Mode setting pins
81	MD1		
82	MD2		
83	VCC	I	Power supply
84	VCC		

DV-505, DVL-909, DV-S9

No.	Pin Name	I/O	Function
85	AVCC	I	Analog power supply
86	AVREF	I	Analog reference power supply
87	PC0/AN0	I	8 bit input (port C) / Analog signal input
88	PC1/AN1		
89	PC2/AN2		
90	PC3/AN3		
91	AVSS	I	Analog Ground
92	PC4/AN4	I	8 bit input (port C) / Analog signal input
93	PC5/AN5		
94	PC6/AN6		
95	PC7/AN7		
96	VSS	I	Ground
97	PB0/TP0/TIOCA2	I/O	16 bit input/output (port B) / Timing pattern output / ITU input capture input/ITU output compare output (channel 2)
98	PB1/TP1/TIOCB2		
99	VCC	I	Power supply
100	PB2/TP2/TIOCA3	I/O	16 bit input/output (port B) / Timing pattern output / ITU input capture input/ITU output compare output (channel 3)
101	PB3/TP3/TIOCB3		
102	PB4/TP4/TIOCA4	I/O	16 bit input/output (port B) / Timing pattern output / ITU input capture input/ITU output compare output (channel 4)
103	PB5/TP5/TIOCB4		
104	PB6/TP6/TOCXA4/TCLKC	I/O	16 bit input/output (port B) / Timing pattern output / ITU output compare output (channel 4) / ITU timer clock input
105	PB7/TP7/TOCXB4/TCLKD		
106	VSS	I	Ground
107	PB8/TP8/RXD0	I/O	16 bit input/output (port B) / Timing pattern output / Receive data input (channel 0)
108	PB9/TP9/TXD0	I/O	16 bit input/output (port B) / Timing pattern output / Transmission data output (channel 0)
109	PB10/TP10/RXD1	I/O	16 bit input/output (port B) / Timing pattern output / Receive data input (channel 1)
110	PB11/TP11/TXD1	I/O	16 bit input/output (port B) / Timing pattern output / Transmission data output (channel 1)
111	PB12/TP12/IRQ4/SCK0	I/O	16 bit input/output (port B) / Timing pattern output / Interruption request / Serial clock input/output (channel 0)
112	PB13/TP13/IRQ5/SCK1	I/O	16 bit input/output (port B) / Timing pattern output / Interruption request / Serial clock input/output (channel 1)

■ MB86371 (DVDM ASSY : IC801)

- MPEG2 Decoder LSI For DVD

• Block Diagram

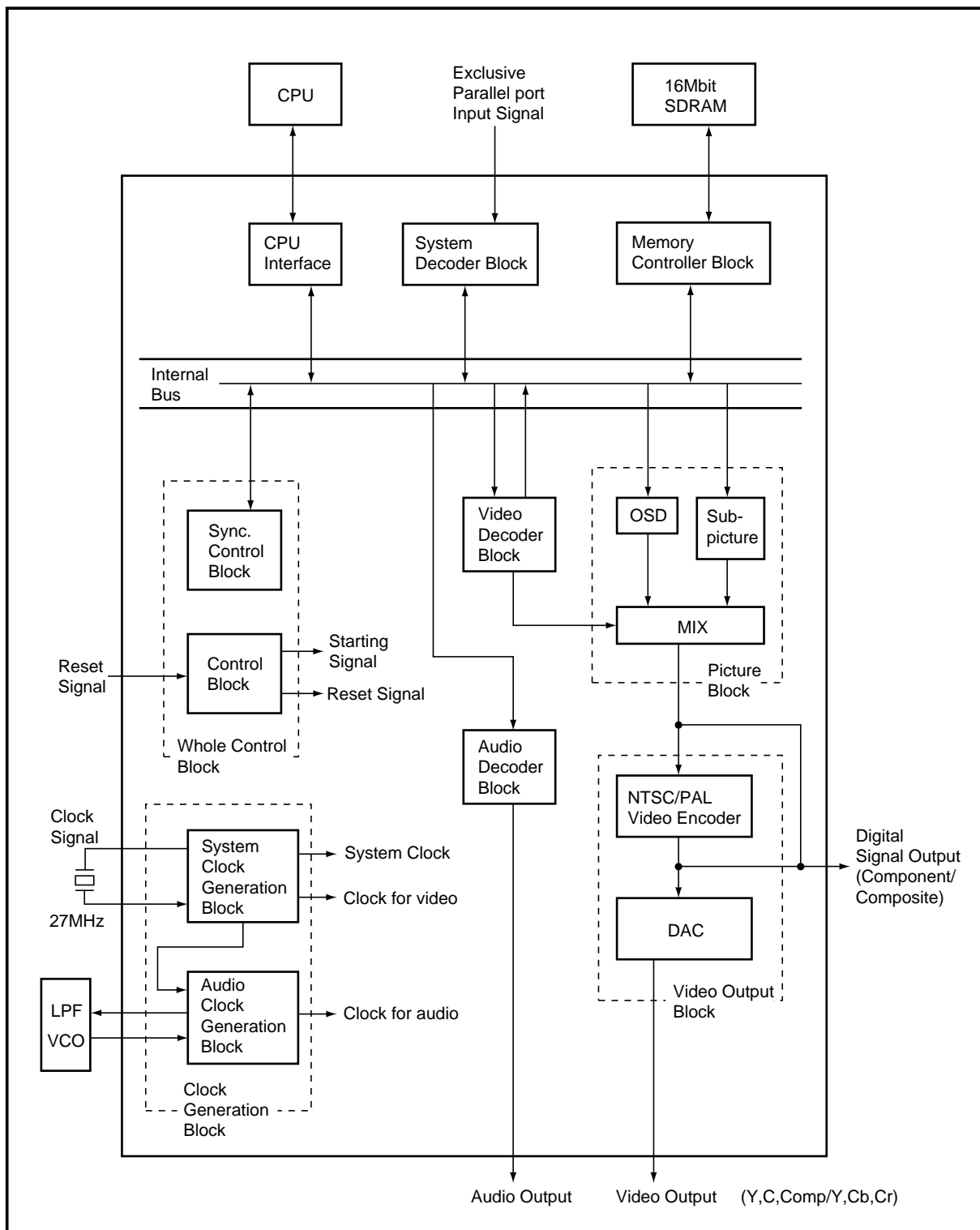

● Pin Function

No.	Pin Name	I/O	Function	No.	Pin Name	I/O	Function	
1	CLKSEL	I	ON/OFF signal of PLL ("H" : ON, "L" : OFF)	27	VDD	-	3.3V power supply	
2	DIGCPN7	O	Digital component signal output (MSB) Digital Y signal output (9-bit) (MSB)	28	DIGCOMP4	O	Digital composite signal output Digital C signal output	
3	VSS	-	GND	29	DIGCOMP3			
4	DIGCPN6	O	Digital component signal output Digital Y signal output (9-bit)	30	DIGCOMP2			
5	DIGCPN5			31	DIGCOMP1			
6	DIGCPN4			32	DIGCOMP0		Digital composite signal output (LSB) Digital C signal output (LSB)	
7	DIGCPN3			33	DACK		O	27 MHz clock output
8	DIGCPN2			34	N.C.		-	Non connection
9	DIGCPN1	35	VSSA3	-	GND (D/A converter)			
10	VDD	-	3.3V power supply	36	ANAC	O	Analog color (C) output signal	
11	DIGCPN0	O	Digital component signal output (LSB) Digital Y signal output (9-bit) (LSB)	37	VDDA3	-	3.3V power supply (for built-in D/A converter only)	
12	RBSEL	O	Cb and Cr discrimination signal at the digital component signal output. LSB at the digital Y signal output.	38	VSSA2	-	GND (D/A converter)	
13	XHS	O	Horizontal sync. output signal	39	ANAY	O	Analog luminance (Y) output signal	
14	XVS	O	Vertical sync. output signal	40	VDDA2	-	3.3V power supply (for built-in D/A converter only)	
15	VSS	-	GND	41	VREF	I	Reference voltage for D/A converter	
16	XRESET	I	LSI reset signal	42	VRO	O	Internal current setting pin of D/A converter	
17	XLDCSYNC	I	External sync. signal input (LD mode)	43	N.C.	-	Non connection	
18	KEY	O	KEY signal for LD and OSD overlay (LD mode)	44	VSSA1	-	GND (D/A converter)	
19	PD	O	Phase comparison result output signal of horizontal sync. (LD mode)	45	ANACOMP	O	Analog composite output signal	
20	VFLD	O	Field discrimination signal at the digital signal output H : even field L : odd field	46	VDDA1	-	3.3V power supply (for built-in D/A converter only)	
21	DIGCOMP9	O	Digital composite signal output (MSB) Digital C signal output (MSB)	47	BF	O	Burst flag signal	
22	DIGCOMP8			48	XBLK	O	H/V composite blanking signal	
23	DIGCOMP7			49	N.C.	-	Non connection	
24	DIGCOMP6			50	VSS	-	GND	
25	DIGCOMP5			51	TEST0	-	Normally, set to "open".	
26	VSS	-	GND	52	TEST1	-	"L" status normally	

No.	Pin Name	I/O	Function	No.	Pin Name	I/O	Function		
53	DAIIN	I	Digital data input of external input (SPDIF)	92	HADRS10	I	CPU address bus signal (MSB)		
54	CDDATA	I	Audio data input of external input (correspond to CD)	93	HADRS9	I	CPU address bus signal		
55	CDLR	I	Data channel clock input of external input (correspond to CD)	94	HADRS8				
56	CDBCK	I	Data clock input of external input (correspond to CD)	95	HADRS7				
57	AODATA3	O	Audio decode data	96	VSS	-	GND		
58	AODATA2			97	VDD	-	3.3V power supply		
59	AODATA1			98	HADRS6	I	CPU address bus signal		
60	VSS	-	GND						
61	VDD	-	3.3V power supply						
62	AODATA0	O	Audio decode data	99	HADRS5				
63	AOPCM	O	Digital audio interface output (compression data)	100	HADRS4	I	CPU address bus signal (LSB)		
64	AODAI	O	Digital audio interface output (decode data)	101	HADRS3				
65	LRCK	O	Data channel clock for D/A and digital filter	102	HADRS2	I/O	CPU data bus signal		
66	AOMCK	O	Master clock for D/A and digital filter	103	HDATA15				
67	BCK	O	Bit clock for D/A and digital filter	104	HDATA14				
68	ICED1	-	Pin for emulator Normally, set to "open".	105	HDATA13				
69	ICED0			106	HDATA12				
70	ICEBRK			107	VSS	-	GND		
71	XDSPRST			108	HDATA11	I/O	CPU data bus signal		
72	VSS	-	GND						
73	N.C.	-	Non connection						
74	TEST2	-	Normally, set to "open".	109	HDATA10				
75	TEST3			110	HDATA9				
76	TEST4			111	HDATA8				
77	TEST5			112	HDATA7				
78	SD7	I	Parallel data input	113	HDATA6	I/O	CPU data bus signal		
79	VDD	-	3.3V power supply						
80	SD6	I	Parallel data input	114	VDD			-	3.3V power supply
81	SD5			115	HDATA5				
82	SD4			116	HDATA4				
83	SD3			117	HDATA3				
84	SD2	-	GND	118	HDATA2	I/O	CPU data bus signal		
85	VSS			-	GND				
86	SD1			I	Parallel data input			119	VSS
87	SD0	I	Parallel data input	120	HDATA1	I/O	CPU data bus signal		
88	XERR	I	Error input signal	121	HDATA0		CPU data bus signal (LSB)		
89	XSACK	I	Acknowledge signal	122	BUSSEL	I	Bus width selection signal (0 : 8-bit bus, 1 : 16-bit bus)		
90	XTEST	I	Set to "H" at normal use	123	XOSDACK	I	OSD data acknowledge signal		
91	SREQ	O	Data request signal	124	XOSDREQ	O	OSD data request signal		
				125	HCPUSEL1	I	CPU selection signal (00 :SPARC, 01 :86 system, 10 :68 system, 11 :Reserve)		
				126	HCPUSEL0				
				127	XINT3	O	Interrupt request signal to the CPU		
				128	XINT2				
				129	XINT1				
				130	VSS	-	GND		

DV-505, DVL-909, DV-S9

No.	Pin Name	I/O	Function	No.	Pin Name	I/O	Function
131	VDD	–	3.3V power supply	170	XMDRCAS	O	CAS signal for SDRAM
132	XINT0	O	Interrupt request signal to CPU	171	XMDRDQM1	O	Input mask / output enable signal for SDRAM
133	XEXTRDY	O	SPARC, 68 system : Ready signal to CPU 86 system : Acknowledge (ACK) signal to CPU	172	VSS	–	GND
134	HRW	I	CPU read / write signal	173	XMDRWE	O	Write enable signal for SDRAM
135	HCLKIN	I	Host clock input	174	XMDRDQM0	O	Input mask / output enable signal for SDRAM
136	XHCS	I	LSI chip select signal	175	MDRDAT8	I/O	Data bus signal for SDRAM
137	XHAS	I	SPARC, 68 system : CPU address strobe 86 system : CPU address status	176	VSS	–	GND
138	XHBE3	I	CPU byte enable signal	177	MDRDAT7	I/O	Data bus signal for SDRAM
139	XHBE2			178	MDRDAT9		
140	XHBE1			179	MDRDAT6		
141	XHBE0			180	MDRDAT10		
142	VSS	–	GND	181	MDRDAT5		
143	MDRADR4	O	Address signal for SDRAM	182	VSS	–	GND
144	MDRADR3			183	VDD	–	3.3V power supply
145	MDRADR5			184	MDRDAT11	I/O	Data bus signal for SDRAM
146	MDRADR2			185	MDRDAT4		
147	VDD	–	3.3V power supply	186	MDRDAT12	I/O	Data bus signal for SDRAM
148	VSS	–	GND	187	MDRDAT3		
149	MDRADR6	O	Address signal for SDRAM	188	MDRDAT13		
150	MDRADR1			189	VSS	–	GND
151	MDRADR7			190	MDRDAT2	I/O	Data bus signal for SDRAM
152	MDRADR0			191	MDRDAT14		
153	MDRADR8		Address signal for SDRAM (LSB)	192	MDRDAT1		
154	VSS	–	GND	193	MDRDAT15		Data bus signal for SDRAM (MSB)
155	TEST6	–	"L" status normally	194	MDRDAT0	I/O	Data bus signal for SDRAM (LSB)
156	TEST7			195	VSS	–	GND
157	TEST8			196	N.C.	–	Non connection
158	TEST9			197	ICK27M	I	System clock input
159	MDRADR10	O	Address signal for SDRAM	198	VSS	–	GND
160	MDRADR9			199	OCK27M	O	System clock output
161	MDRADR11			Address signal for SDRAM (MSB)	200	VSSA(VCO)	–
162	XMDRCS	O	Chip select signal for SDRAM	201	VDDA(VCO)	–	3.3V power supply (for VCO only)
163	MDRCKE	O	Clock enable signal for SDRAM	202	ILPF	O	PLL block inverter output for audio
164	VSS	–	GND	203	MLPF	I	PLL block inverter input for audio
165	VDD	–	3.3V power supply	204	OLPF	O	Phase detector output for audio
166	XMDRRAS	O	RAS signal for SDRAM	205	OVCO	I	VCO input for audio clock
167	MDRCLK	O	Clock output signal for SDRAM	206	VSS	–	GND
168	VSS	–	GND	207	XPLLST	I	PLL section reset signal
169	MDRCLKIN	I	Clock input signal for SDRAM	208	XSYNCRST	I	SYNC reset signal

■ MB811171622A-100FN (DVD M ASSY : IC802)

- Code Buffer (16M bit SDRAM)

● Block Diagram

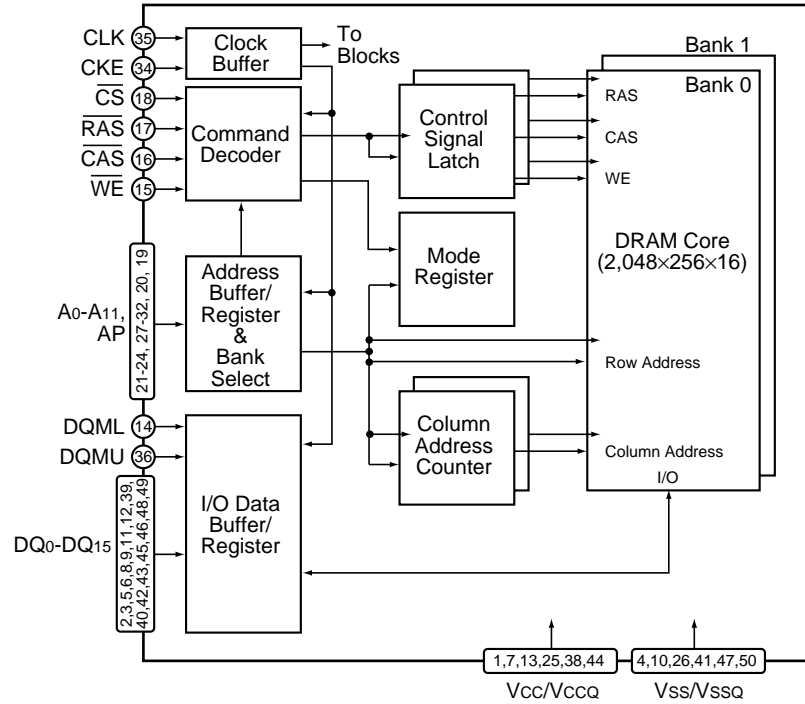

● Pin Function

No.	Pin Name	Function	No.	Pin Name	Function
1	VCC	Power supply (+ 3.3V)	26	VSS	Ground
2	DQ0	Data input/output	27	A4	Address input Row : A0 to A10 , Column : A0 to A7
3	DQ1		28	A5	
4	VSSQ	Ground	29	A6	
5	DQ2	Data input/output	30	A7	
6	DQ3		31	A8	
7	VCCQ	Power supply (+ 3.3V)	32	A9	
8	DQ4	Data input/output	33	DU	Don't use (use for open)
9	DQ5		34	CKE	Clock enable
10	VSSQ	Ground	35	CLK	Clock input
11	DQ6	Data input/output	36	DQMU	Input mask / Output enable
12	DQ7		37	DU	Don't use (use for open)
13	VCCQ	Power supply (+ 3.3V)	38	VCCQ	Power supply (+ 3.3V)
14	DQML	Input mask / Output enable	39	DQ8	Data input/output
15	WE	Write enable	40	DQ9	
16	CAS	Column address strobe	41	VSSQ	Ground
17	RAS	Row address strobe	42	DQ10	Data input/output
18	CS	Chip select	43	DQ11	
19	A11 (BA)	Bank select	44	VCCQ	Power supply (+ 3.3V)
20	A10/AP	Address input Row : A0 to A10 , Column : A0 to A7 / Auto pre-charge enable	45	DQ12	Data input/output
21	A0	Address input Row : A0 to A10 , Column : A0 to A7	46	DQ13	
22	A1		47	VSSQ	Ground
23	A2		48	DQ14	Data input/output
24	A3		49	DQ15	
25	VCC		Power supply (+ 3.3V)	50	VSS

■ **CY2081SL-611 (DVDM ASSY : IC813)**

- Clock Generate IC

• **Block Diagram**

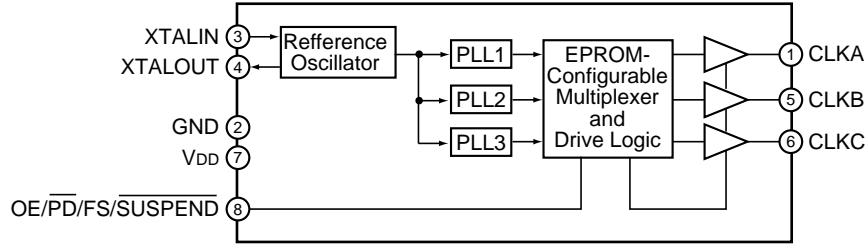

• **Pin Function**

No.	Pin Name	Function
1	CLKA	Configurable clock output
2	GND	Ground
3	XTALIN	Reference crystal input or external reference clock input
4	XTALOUT	Reference crystal feedback
5	CLKB	Configurable clock output
6	CLKC	Configurable clock output
7	VDD	Voltage supply
8	OE/PD/FS/SUSPEND	Output control pin Either active-High output enable, active-Low power down, CLKA frequency select, or active-Low suspend input

■ PD2058A (DVDM ASSY : IC901)(DV-505 and DVL-909 only)

• Digital Signal Processor For Audio

• Block Diagram

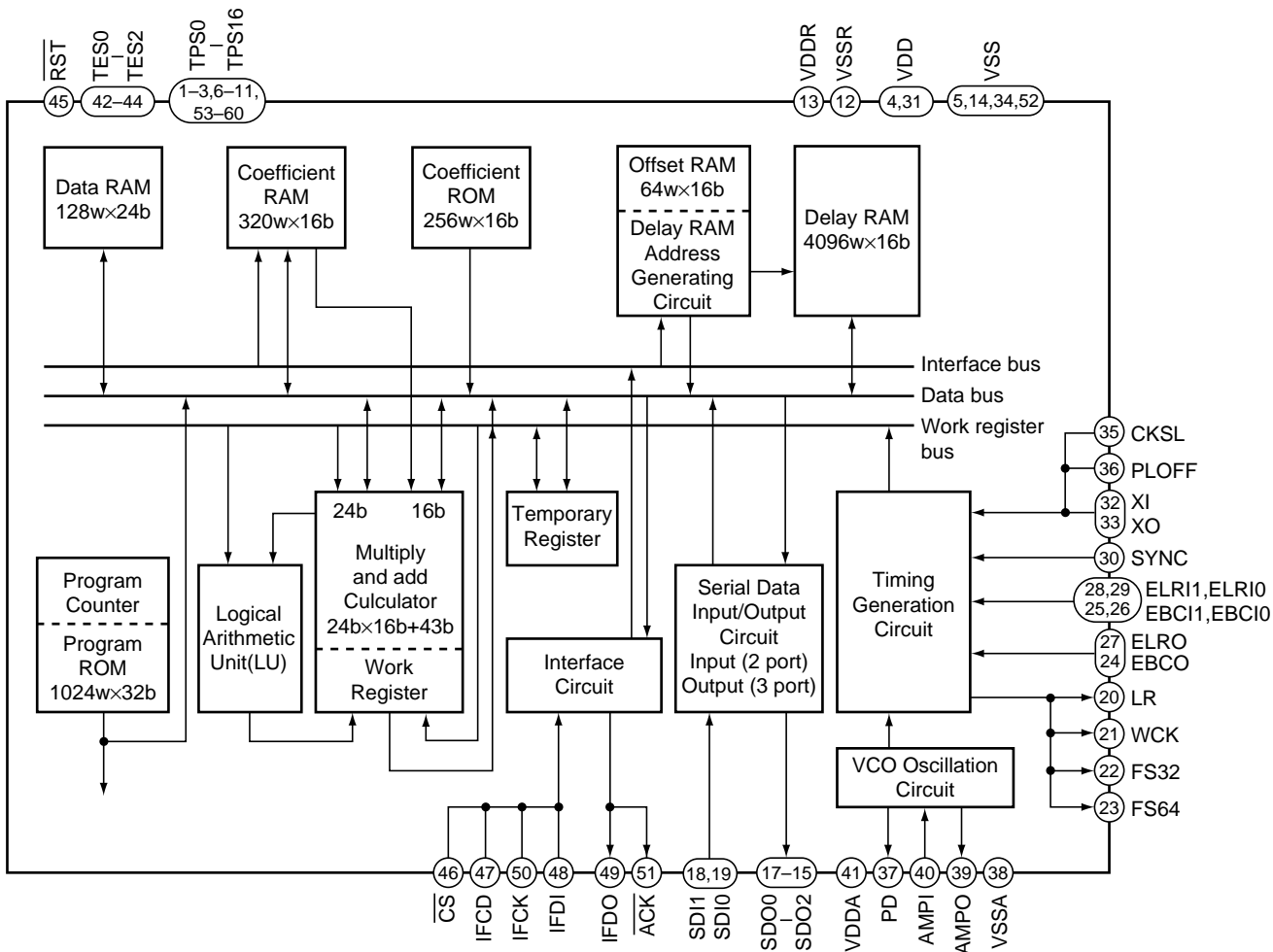

• Pin Function

No.	Pin Name	I/O	Function
1	TP8	○	Test data output pin Normally, use with open.
2	TP7		
3	TP6		
4	VDD	-	Power supply pin
5	VSS	-	Ground pin
6	TP5	○	Test data output pin Normally, use with open.
7	TP4		
8	TP3		
9	TP2		
10	TP1		
11	TP0		

DV-505, DVL-909, DV-S9

No.	Pin Name	I/O	Function	
12	VSSR	–	Ground pin for internal delay RAM (DLRAM)	
13	VDDR	–	Power supply pin for internal delay RAM (DLRAM)	
14	VSS	–	Ground pin	
15	SDO2	O	Serial data output pin Output data length is able to select the 24-bit or 16-bit by controlling the microprocessor.	
16	SDO1			
17	SDO0			
18	SDI1	I	Serial data input pin Input data length is able to select the 24-bit or 16-bit by controlling the microprocessor.	
19	SDI0			
20	LR	O	LR clock output pin (1 fs)	
21	WCK	O	Word clock output pin (2 fs)	
22	FS32	O	Bit clock output pin (32 fs)	
23	FS64	O	Bit clock output pin (64 fs)	
24	EBC0	I	Bit clock input pin Inputs shift clock for SDO0/1/2 data output.	
25	EBC11	I	Bit clock input pin	For SDI1 data input
26	EBC10		Inputs shift clock for SDI0/1 data input.	For SDI0 data input
27	ELRO	I	LR clock input pin Inputs LR clock for SDO0/1/2 data output.	
28	ELR11	I	LR clock input pin	For SDI1 data input
29	ELR10		Inputs LR clock for SDI0/1 data input.	For SDI0 data input
30	SYNC	I	Sync. signal input pin Turn the program counter into "0" forcibly by the edge of SYNC signal. Moreover, set the polarity by controlling the microprocessor.	
31	VDD	–	Power supply pin	
32	XI	I	Crystal oscillator connection pin / external clock input pin	
33	XO	O	Crystal oscillator connection pin	
34	VSS	–	Ground pin	
35	CKSL	I	Oscillation clock switch pin L : correspond to 384 fs H : correspond to 512 fs	
36	PLOFF	I	X'tal oscillation mode / VCO oscillation mode switch pin L :built-in VCO oscillation mode H :X'tal oscillation mode	
37	PD	O	Phase comparison data output pin	
38	VSSA	–	Analog ground pin	
39	AMPO	O	Amp. output pin for low-pass filter	
40	AMPI	I	Amp. input pin for low-pass filter	
41	VDDA	–	Analog power supply pin	
42	TES0	I	Test pin Normally, use for "H" or open.	
43	TES1			
44	TES2			
45	RST	I	Reset signal input pin	
46	CS	I	Chip select signal input pin When CS is L active, data is able to transfer from the microprocessor.	
47	IFCD	I	Command or data input mode selection pin from the microprocessor Recognize the command for "H" period and the data for "L" period.	
48	IFDI	I	Microprocessor data input pin Receive the command and data by LSB first.	
49	IFDO	O	Data output pin of data bus (DBUS) Transmit the data of data bus to the microprocessor by LSB first.	
50	IFCK	I	Shift clock input pin for microprocessor data	
51	ACK	O	Acknowledge signal output pin for microprocessor When parity of command and data is OK, outputs the acknowledge signal.	
52	VSS	–	Ground pin	
53	TP16	O	Test data output pin Normally, use with open.	
54	TP15			
55	TP14			
56	TP13			
57	TP12			
58	TP11			
59	TP10			
60	TP9			

5. FL INFORMATION

■ VAW1046 (FLKB ASSY : V101)(DV-505 and DVL-909 only)

• FL DISPLAY

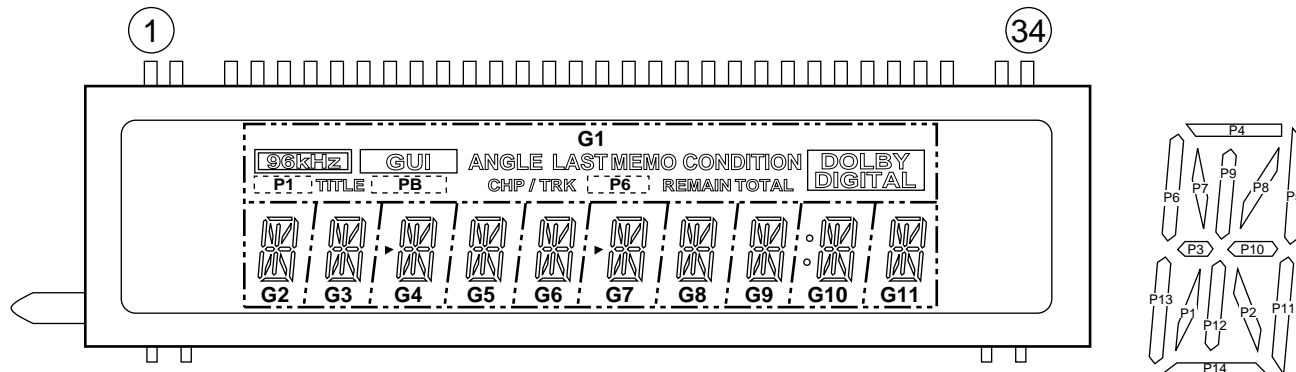

• ANODE AND GRID ASSIGNMENT

	G1	G2	G3	G4	G5	G6	G7	G8	G9	G10	G11
P1	P1	P1	P1	P1	P1	P1	P1	P1	P1	P1	P1
P2	ANGLE	P2	P2	P2	P2	P2	P2	P2	P2	P2	P2
P3	TITLE	P3	P3	P3	P3	P3	P3	P3	P3	P3	P3
P4	LAST MEMO	P4	P4	P4	P4	P4	P4	P4	P4	P4	P4
P5	CONDITION	P5	P5	P5	P5	P5	P5	P5	P5	P5	P5
P6	P6	P6	P6	P6	P6	P6	P6	P6	P6	P6	P6
P7	CHP/TRK	P7	P7	P7	P7	P7	P7	P7	P7	P7	P7
P8	P8	P8	P8	P8	P8	P8	P8	P8	P8	P8	P8
P9	REMAIN	P9	P9	P9	P9	P9	P9	P9	P9	P9	P9
P10	DOLBY DIGITAL	P10	P10	P10	P10	P10	P10	P10	P10	P10	P10
P11	GUI	P11	P11	P11	P11	P11	P11	P11	P11	P11	P11
P12	96kHz	P12	P12	P12	P12	P12	P12	P12	P12	P12	P12
P13		P13	P13	P13	P13	P13	P13	P13	P13	P13	P13
P14		P14	P14	P14	P14	P14	P14	P14	P14	P14	P14
P15	TOTAL			▷			▷			◦	

• PIN ASSIGNMENT

Pin No.	1	2	3	4	5	6	7	8	9	10	11	12	13	14	15	16	17
Assignment	F1	F1	NP	P15	P14	P13	P12	P11	P10	P9	P8	P7	P6	P5	P4	P3	P2
Pin No.	18	19	20	21	22	23	24	25	26	27	28	29	30	31	32	33	34
Assignment	P1	G11	G10	G9	G8	NL	NL	G7	G6	G5	G4	G3	G2	G1	NP	F2	F2

F1, F2 : Filament G1~G11 : Grid P1~P15 : Anode NP : No Pin NL : No Lead